

AT ALL TIMES WATER RESISTANT CONNECTORS NOT IN USE SHOULD BE COVERED WITH A CONEC WATER RESISTANT CAP OR WATER TIGHT HOOD.

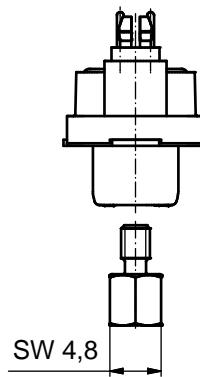

SEE NOTE 13

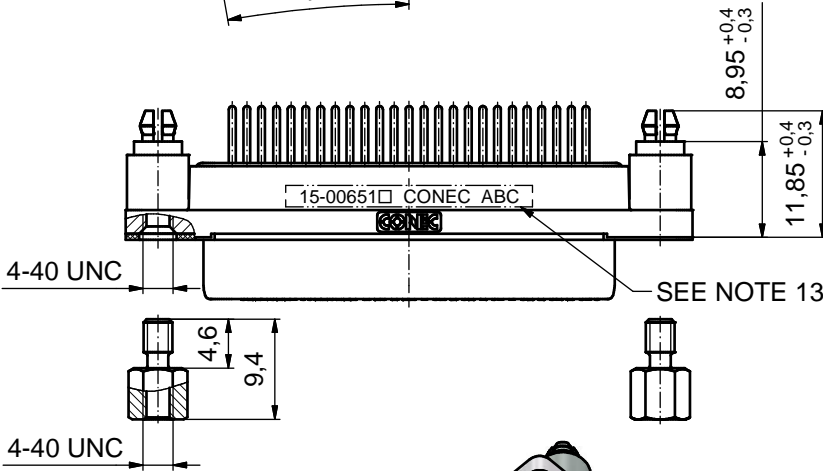
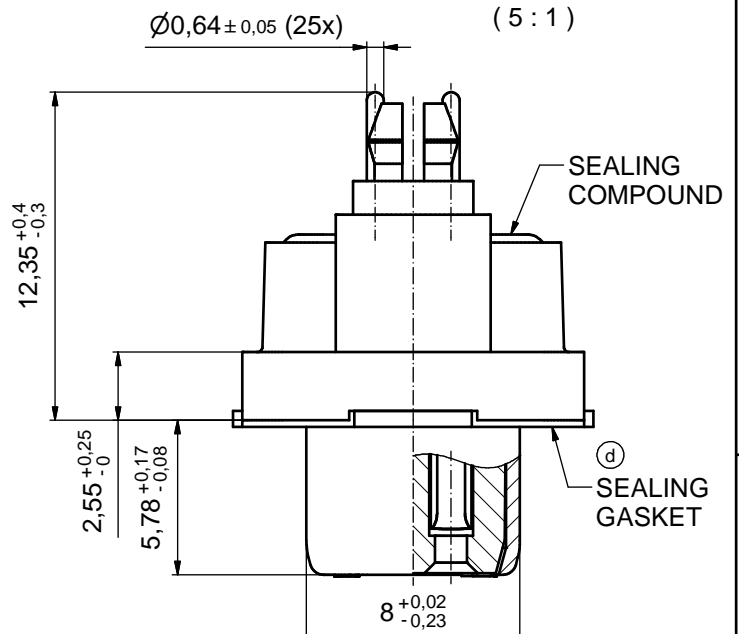
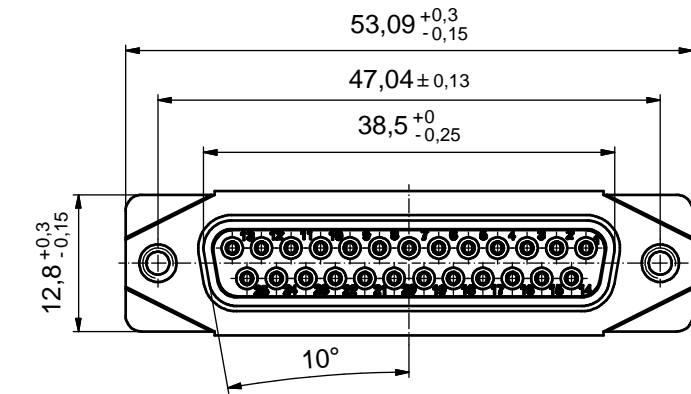
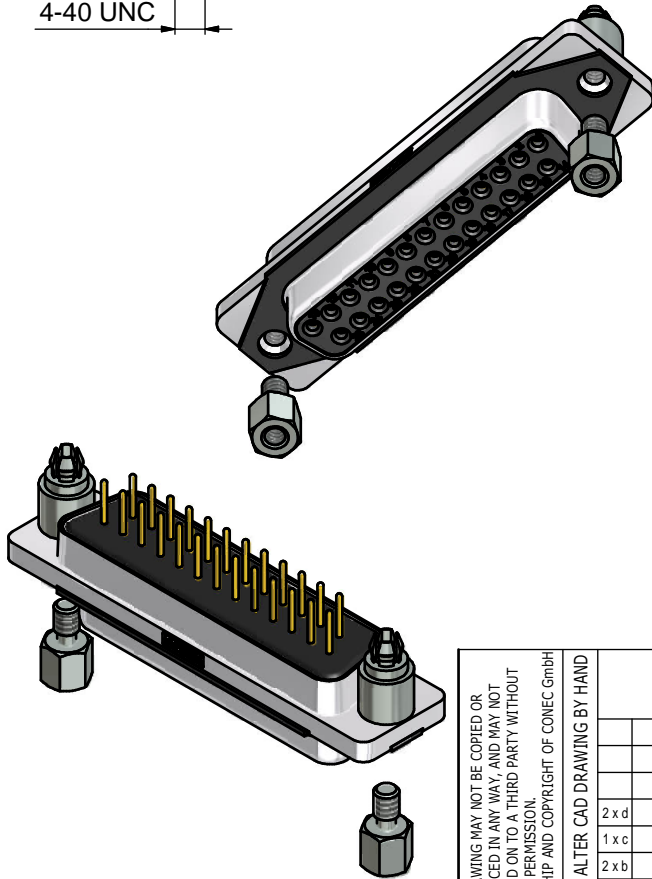

RoHS compliant

NOTES:

- FOR WAVESOLDERING (SOLDER BATH TEMPERATURE 265°C FOR 8 SEC. AND SOLDER PREHEAT 150°C FOR 180 SEC.)
- IP RATING: IP 67
- SEALED TO WITHSTAND PRESSURE UP TO 1,45 PSI FOR 30 MINUTES AFTER SOLDERING
- METAL SHELL: ZINC DIE CAST; min. 50µin NICKEL PLATING over COPPER
- INSULATORS: PBT GF UL 94 V-0
- SEALING GASKET: SILICONE
- SEALING COMPOUND: EPOXY
- CONTACTS: COPPER ALLOY; PLATING (SEE PART-NO.):
 PLEASE ADD 1 for 30µin HARD GOLD over min. 50µin NICKEL
 PLEASE ADD 3 for GOLD FLASH over NICKEL
- REAR SPACER CLIPS: COPPER ALLOY; min. 200µin TIN over 80µin NICKEL
 PCB-HOLE: $\varnothing 3,1 \pm 0,1$ mm; PCB THICKNESS 1,6mm
- HEXLOCKING SCREWS: STAINLESS STEEL
- P.C.B. HOLE DRILLINGS and RECOMMENDED PANEL CUT-OUT ON SHEET 2
- RECOMMENDED TORQUE FOR MOUNTING SCREW
 35Ncm (3.1 in.LB) / max. 67Ncm (6 in.LB)
- CONNECTOR IS PART MARKED: **15-00651 CONEC ABC** (see note 8)

THIS DRAWING MAY NOT BE COPIED OR REPRODUCED IN ANY WAY, AND MAY NOT BE PASSED ON TO A THIRD PARTY WITHOUT WRITTEN PERMISSION. OWNERSHIP AND COPYRIGHT OF CONEC GmbH				tolerance		dim. in mm	scale: 2:1 (5:1)	
				date			material:	
				drawn	25.09.14	Lehmenkühler		title: D-SUB FEMALE 25pos. SOLDER PIN STRAIGHT with closed 4-40 UNC thread and rear spacer clip
				appd.	26.01.15	Fischer		
2 x d	Ä6417	17.05.17	Lehm,	norm			dwg no:	
1 x c	Ä5827	25.09.15	Unkrüer	d-old			DIN-A3	
2 x b	Ä5800	07.09.15	M.H.			15K1A1550		
a	Original					sh: 1		
rev.	description	date	name	CONEC		part no: 15-00651 (see note 8)		

P.C.B. HOLE DRILLINGS

(P.C.B. TOP SIDE)

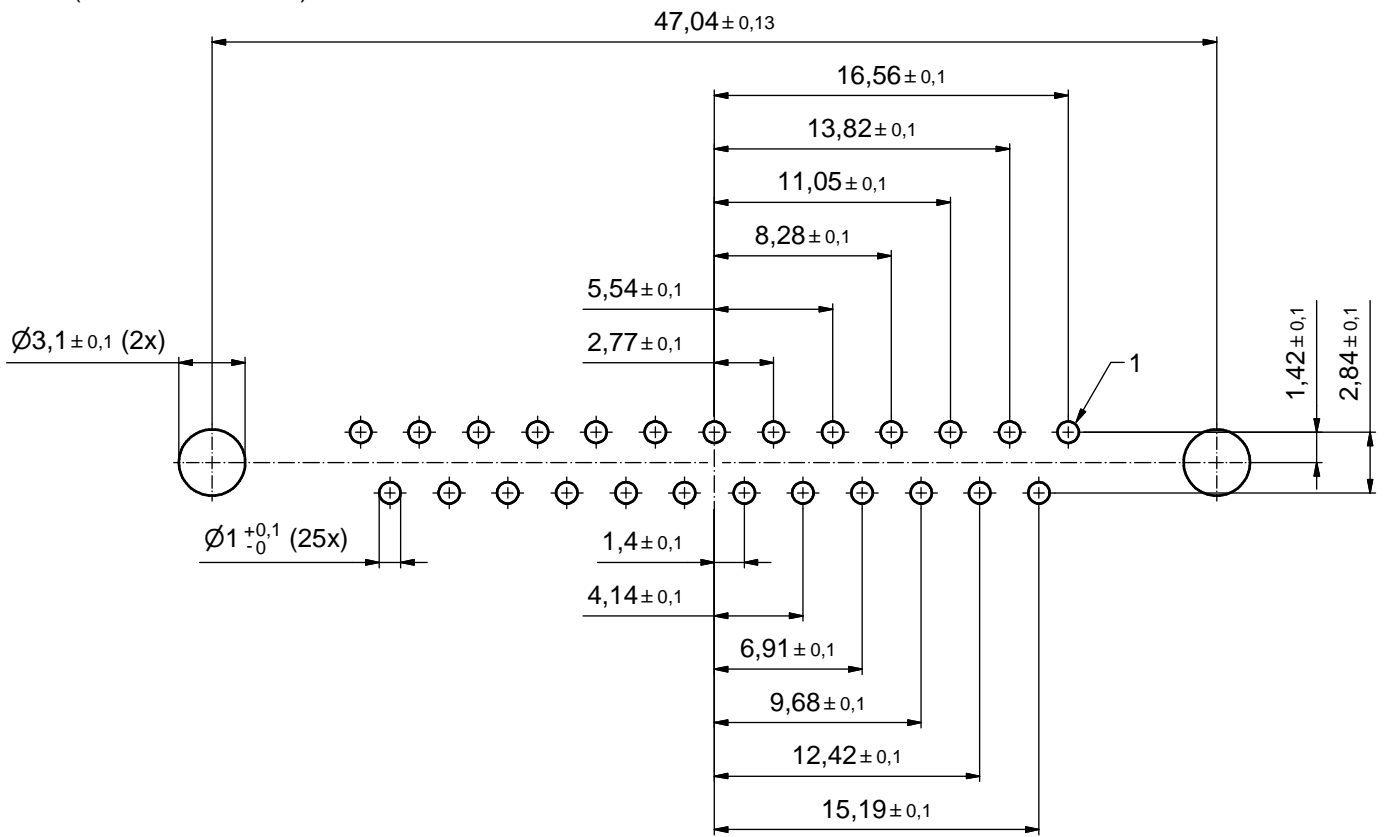

RECOMMENDED PANEL CUT-OUT

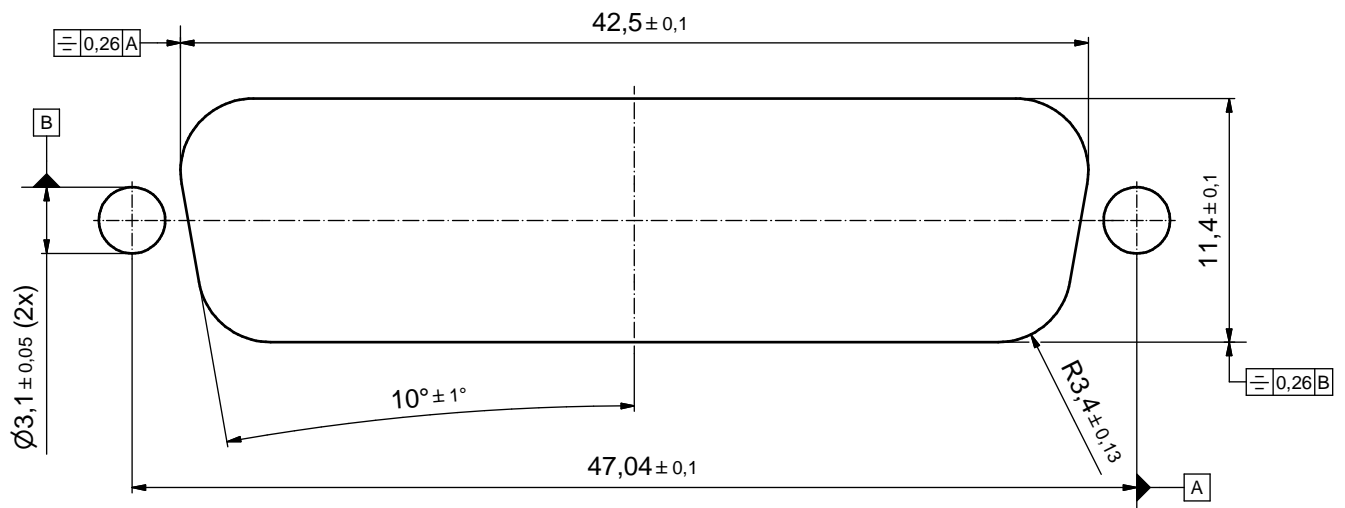

THIS DRAWING MAY NOT BE COPIED OR REPRODUCED IN ANY WAY, AND MAY NOT BE PASSED ON TO A THIRD PARTY WITHOUT WRITTEN PERMISSION. OWNERSHIP AND COPYRIGHT OF CONEC GmbH DO NOT ALTER CAD DRAWING BY HAND				tolerance		scale: 4:1
				dim. in mm		material: SEE SHEET 1
	drawn	25.09.14	Lehmenkühler	date	name	title: P.C.B. HOLE DRILLINGS RECOMMENDED PANEL CUT-OUT D-SUB FEMALE 25pos. SOLDER PIN STRAIGHT
	appd.	26.01.15	Fischer	norm		
				d-old		
rev.	a	Original				dwg no: 15K1A1550
						DIN-A3
						sh: 2
						part no: SEE SHEET 1

