

REVISIONS					
REV	DATE	DESCRIPTION	BY	CHK	APP'D
B1	02NOV2021	REVISED PER ECR-21-119230	SS	VS	

- PARTS COMPLY TO AMP SOLDERABILITY SPECIFICATION 109-11-3.
- DIMENSIONS IN BRACKETS ARE IN INCHES.
- $\triangle$  CIRCUIT IDENTIFICATION CHARACTERS ARE ADJACENT TO THE INDICATED CAVITIES, BUT LOCATION AND ORIENTATION MAY DIFFER FROM PRINT.
- FLAMMABILITY V2 FOR THICKNESS 0.38mm, 1.5mm, and 3.0mm PER IEC 60695-11-10.
- GLOW-WIRE FLAMMABILITY (GWFI) 800°C FOR THICKNESS 0.38mm AND 0.75mm PER IEC 60695-2-12.
- GLOW-WIRE FLAMMABILITY (GWFI) 960°C FOR THICKNESS 1.5mm AND 3.0mm PER IEC 60695-2-12.
- GLOW-WIRE IGNITION (GWIT) 825°C FOR THICKNESS 0.38mm, 0.75mm, 1.5mm AND 3.0mm PER IEC 60695-2-13.
- DIMENSIONS SHOWN REPRESENT PRODUCT IN DRY CONDITION. ADDITIONAL 2% GROWTH DUE TO END USE LOCATION MOISTURE ABSORPTION MAY OCCUR AND SHOULD BE ACCOUNTED FOR.

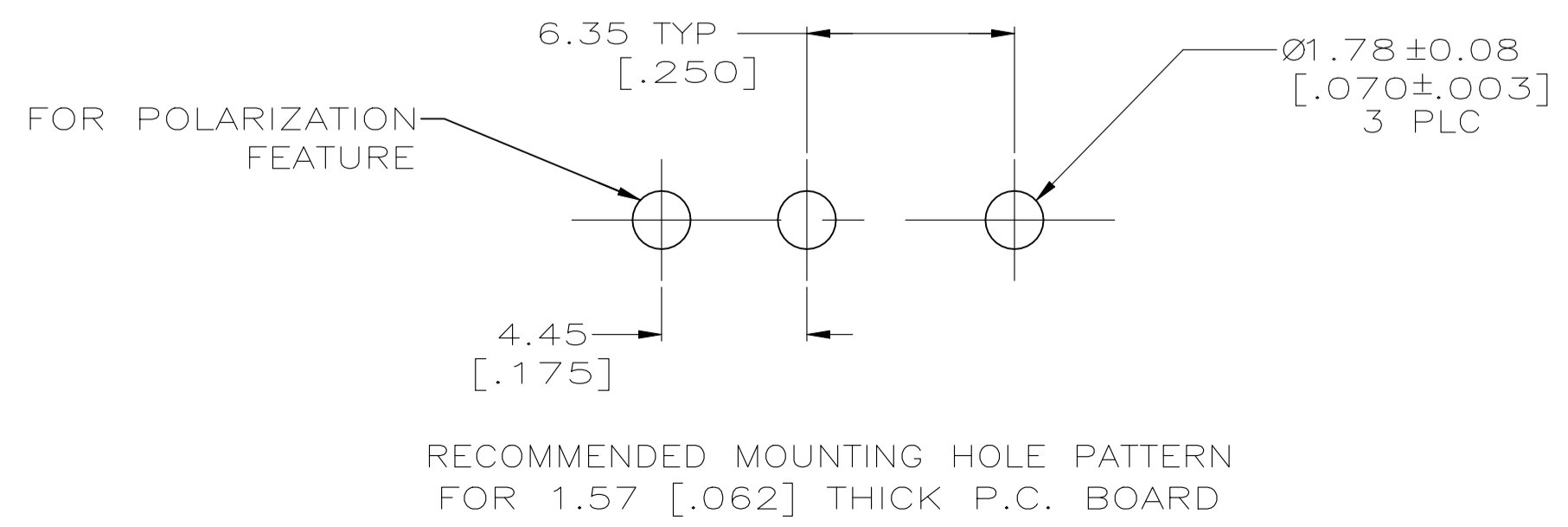
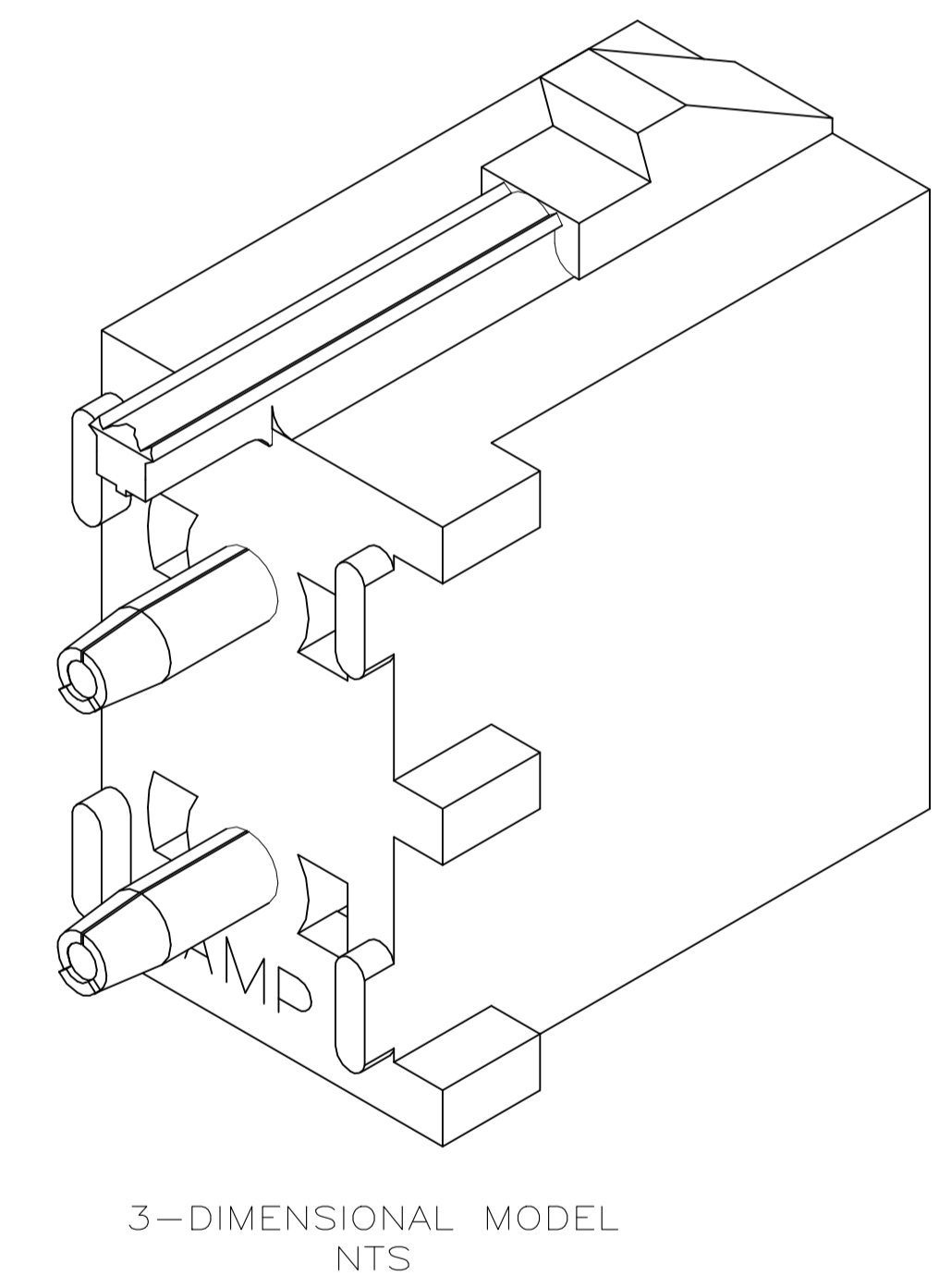
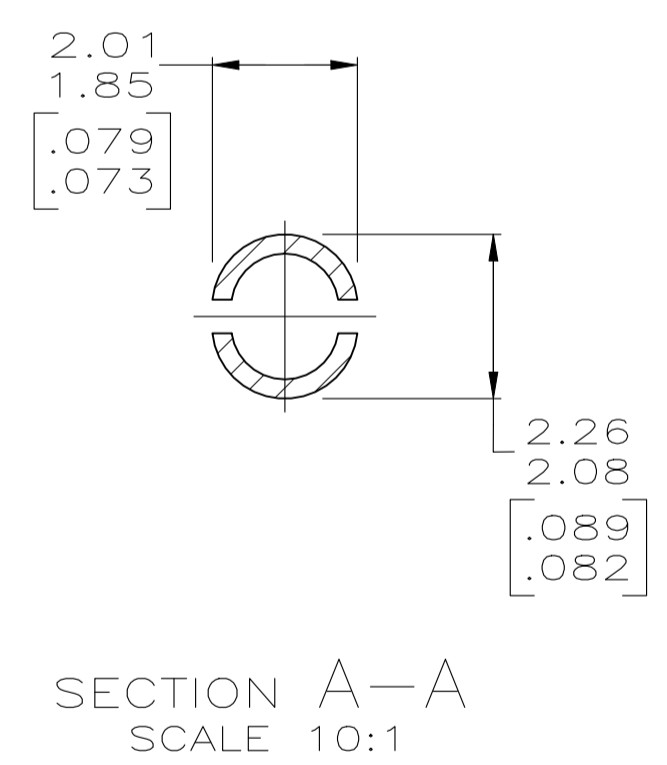
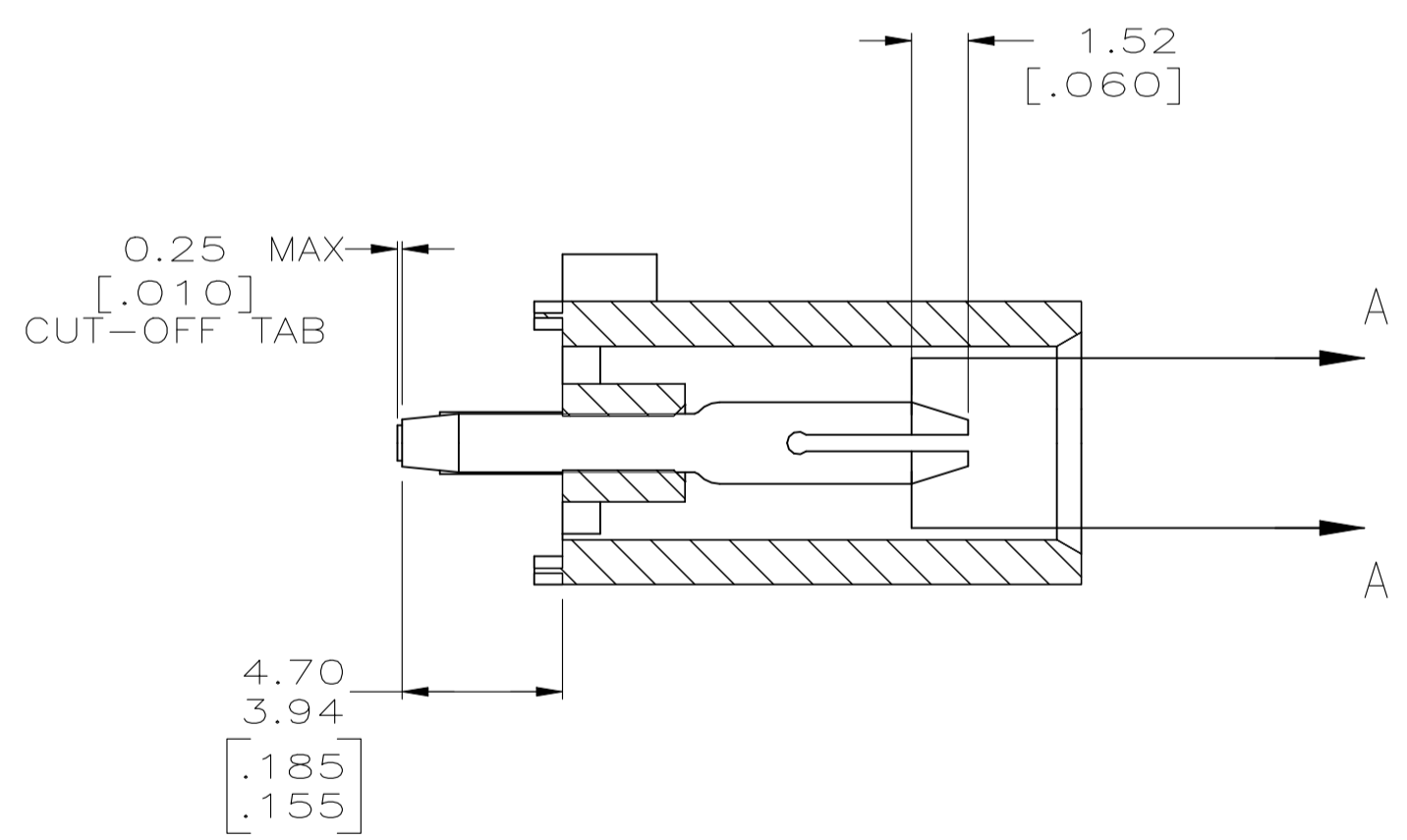
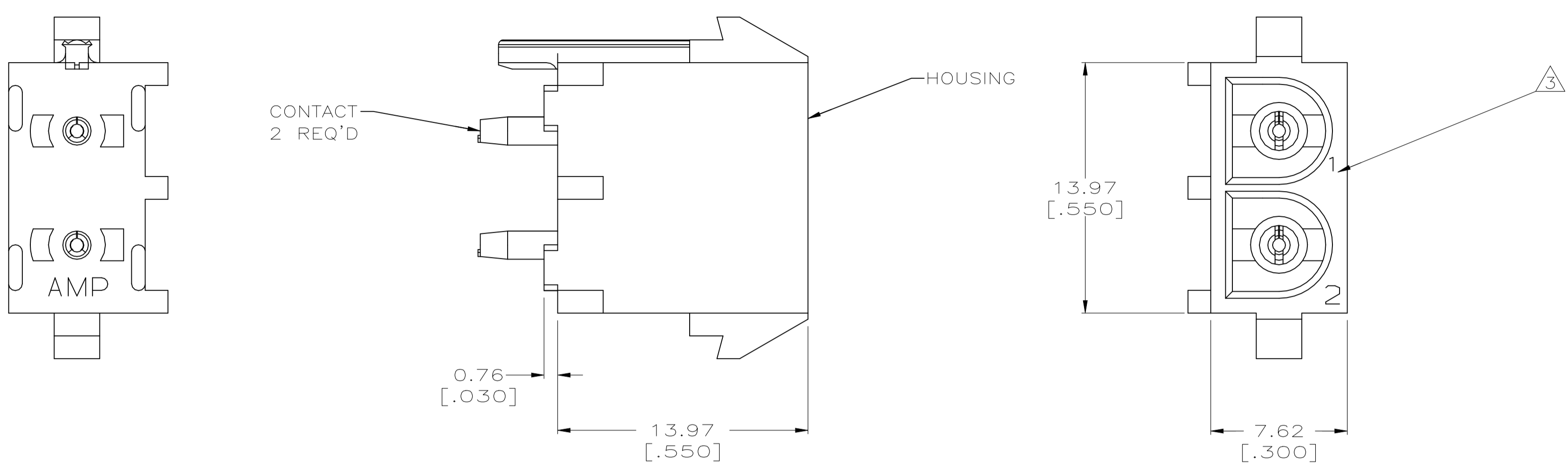

PHOSPHOR BRONZE, PRE-TIN	NYLON,UL94V-2,NATURAL	1586955-1
PIN CONTACT MATERIAL AND FINISH	HOUSING MATERIAL	PART NUMBER

THIS DRAWING IS A CONTROLLED DOCUMENT.		DIN K. WHITAKER 26JUL2007	 TE Connectivity
DIMENSIONS: mm [INCHES]		CHK D. COLEY 26JUL2007	
TOLERANCES UNLESS OTHERWISE SPECIFIED:		APP'D D. COLEY 26JUL2007	NAME
0 PLC ± -			PIN HEADER ASSEMBLY, POLARIZED, 2 CIRCUIT UNIVERSAL MATE-N-LOK(TM)
1 PLC ± -			PRODUCT SPEC
2 PLC ± 0.13 [.005]			APPLICATION SPEC
3 PLC ± -			SIZE
4 PLC ± -			CAGE CODE
ANGLES ± α°30'			DRAWING NO
MATERIAL SEE TABLE	FINISH SEE TABLE	WEIGHT 0.000000	RESTRICTED TO
		A1 00779	SCALE 5:1
		1586955	SHEET 1 of 1
		CUSTOMER DRAWING	REV B1