

DC250A Quick Start Guide

The DC250A demonstration board contains all of the circuitry needed for evaluation of the LTC1503CMS8-1.8/2 inductorless switching regulator IC. To begin, simply connect an input power supply to V_{IN} (E3) and GND (E4) (see Figure 1). Connect the load between V_{OUT} (E2) and GND (E4). Once power is applied, the LTC1503CMS8-1.8/2 will start up automatically and produce a regulated 1.8V/2V output voltage.

With an input supply of between 2.4V and 6V, the output will regulate correctly for any load current up to 100mA. Accidental short circuits from V_{OUT} to GND will not damage the LTC1503CMS8-1.8/2 or DC250A demonstration board.

To place the LTC1503CMS8-1.8/2 in shutdown, simply connect the $\overline{\text{SHDN/SS}}$ pin (E5) to GND (E4). To re-start the LTC1503CMS8-1.8/2 remove the ground connection from SHDN/SS. The IC will automatically pull up on the SHDN/SS pin and regulate to the correct voltage at its output. Inrush current can be controlled by the use of jumper JP1. If JP1 is in place, soft-start capacitor C3 is connected to the SHDN/SS pin. C3 limits the inrush current by limiting the dV/dt of the output voltage upon start-up. Without JP1, the LTC1503CMS8-1.8/2 will deliver current to C_{OUT} , the output capacitor, as quickly as possible until the regulation voltage is reached.

To evaluate the soft-start feature of the LTC1503CMS8-1.8/2 an open-drain output from a microcontroller or a discrete transistor can be connected to the $\overline{\text{SHDN/SS}}$ pin (E5). For example, using a discrete transistor, connect the drain of the device to $\overline{\text{SHDN/SS}}$ (E5) and the source to GND (E4). The gate can be manipulated to a suitable control voltage or pulsed waveform with a function generator. To see the soft start characteristics on an oscilloscope, a load resistor will be needed to discharge the output capacitor. A 33ohm resistor will discharge the 10 μ F output capacitor in about 1ms.

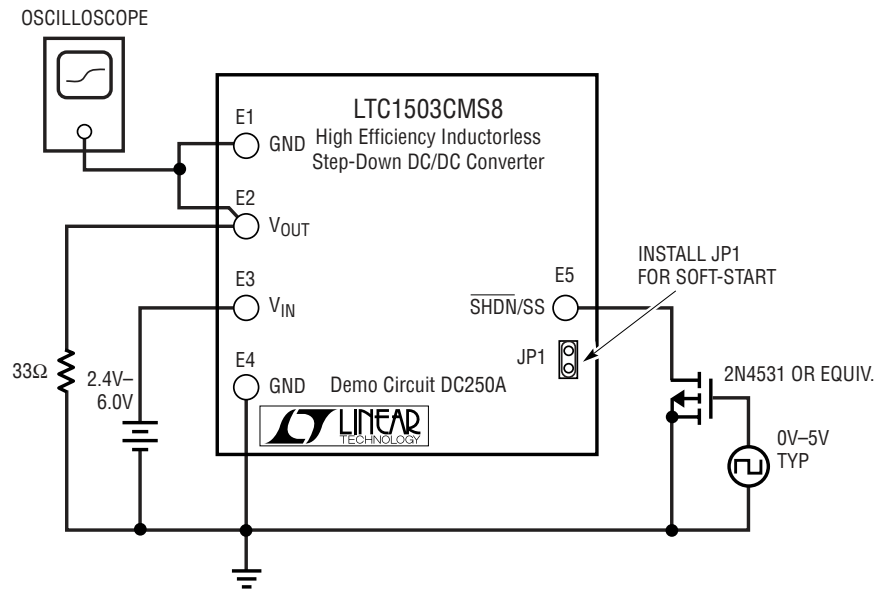

Figure 1. DC250A Hook-Up Diagram