

FEATURES

- 250 MSPS Update Rate
- Low Glitch Impulse
- Complete Composite Functions
- Internal Voltage Reference
- Single -5.2 V Supply

APPLICATIONS

- Raster Scan Displays
- Color Graphics
- Automated Test Equipment
- TV Video Reconstruction

GENERAL DESCRIPTION

The AD9701 is a high-speed, 8-bit digital-to-analog converter with fully integrated composite video functions. High-speed ECL input registers provide synchronous operation of data and control functions up to 250 MSPS.

The AD9701 incorporates onboard control functions including horizontal sync, blanking, reference white level, and a 10% bright signal for highlighting. The setup level is also adjustable from 0 IRE units to 20 IRE units, through the control pin. An internal voltage reference allows the AD9701 to operate as a stand-alone video reconstruction DAC.

The AD9701 is available as an industrial temperature range device, -25°C to +85°C, and as an extended temperature range

FUNCTIONAL BLOCK DIAGRAM

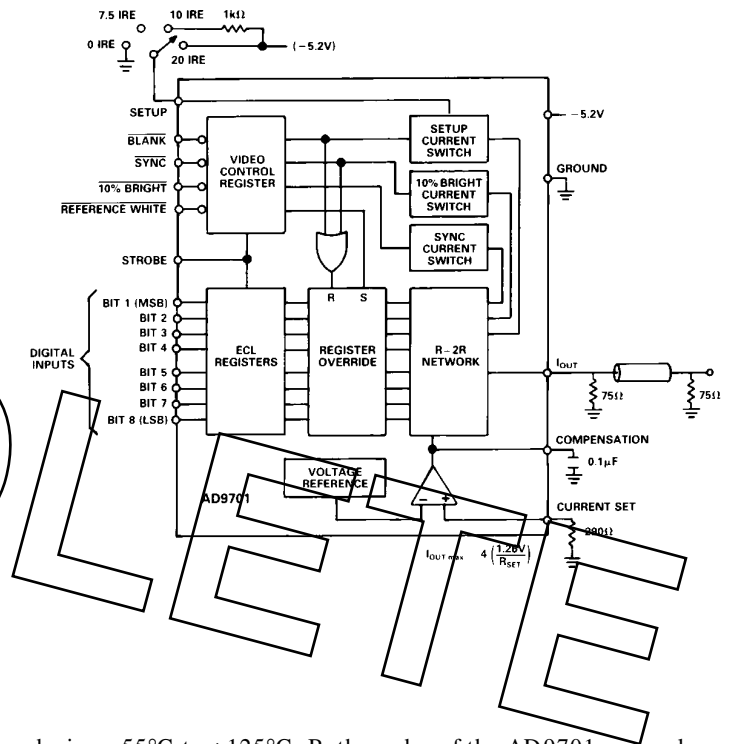

device, -55°C to +125°C. Both grades of the AD9701 are packaged in a 22-pin ceramic DIP, with the extended temperature device also available in a 28-pin LCC package.

PIN CONFIGURATIONS

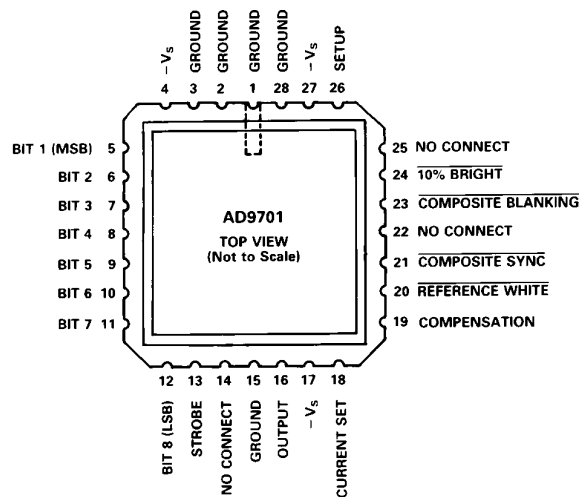
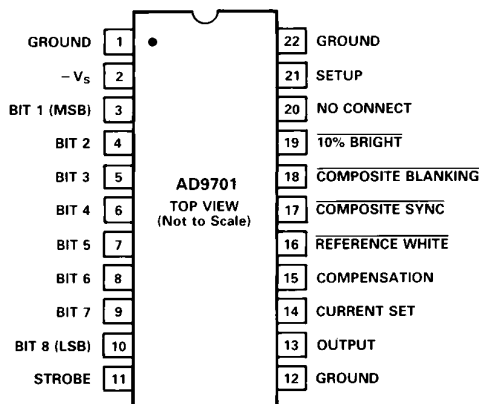

REV. A

Information furnished by Analog Devices is believed to be accurate and reliable. However, no responsibility is assumed by Analog Devices for its use, nor for any infringements of patents or other rights of third parties which may result from its use. No license is granted by implication or otherwise under any patent or patent rights of Analog Devices.

AD9701—SPECIFICATIONS

ABSOLUTE MAXIMUM RATINGS¹

Supply Voltage ($-V_S$)	-7 V
Digital Input Voltages (including STROBE, SYNC, BLANKING, 10% BRIGHT, and REFERENCE WHITE)	0 V to $-V_S$
Analog Output Current	37 mA
Power Dissipation (+25°C Free Air) ²	780 mW

Operating Temperature Range

AD9701BQ	-25°C to +85°C
AD9701SQ/SE	-55°C to +125°C
Storage Temperature Range	-65°C to +150°C
Junction Temperature	+175°C
Lead Soldering Temperature (10 sec)	+300°C

ELECTRICAL CHARACTERISTICS (Supply Voltages = -5.2 V; R_L = 37.5 Ω ; Setup = 0 V, unless otherwise noted)

Parameter	Temp	AD9701BQ			AD9701SQ/SE			Units
		Min	Typ	Max	Min	Typ	Max	
RESOLUTION		8			8			Bits
DC ACCURACY								
Differential Linearity	+25°C		0.25	0.5		0.25	0.5	LSB
	Full			1.0			1.0	LSB
Integral Linearity	+25°C		0.25	0.5		0.25	0.5	LSB
	Full			1.0			1.0	LSB
Monotonicity	Full	Guaranteed			Guaranteed			
INITIAL OFFSET ERROR ³								
Zero-Scale Offset Error ⁴	+25°C		0.05	0.9		0.05	0.9	mV
	Full			0.9			0.9	mV
Zero-Scale Offset Drift Coefficient	Full		2			2		$\mu\text{V}/^\circ\text{C}$
Full-Scale Drift Coefficient	Full		50			50		$\mu\text{V}/^\circ\text{C}$
ANALOG OUTPUT								
Voltage Output ⁵								
10% Bright ⁶	Full	-0.9	0		-0.9	0		mV
Reference White	Full	-67.45	-71	-74.55	-67.45	-71	-74.55	mV
Blanking (Setup = 0 IRE) ⁷	Full	-698.55	-708.5	-718.45	-698.55	-708.5	-718.45	mV
Sync (Setup = 0 IRE) ⁸	Full	-979.25	-993.5	-1007.75	-979.25	-993.5	-1007.75	mV
Current Output ⁵								
10% Bright ⁶	Full	-0.024	0		-0.024	0		mA
Reference White	Full	-1.805	-1.9	-1.996	-1.805	-1.9	-1.995	mA
Blanking (Setup = 0 IRE) ⁷	Full	-18.63	-18.9	-19.16	-18.63	-18.9	-19.16	mA
Sync (Setup = 0 IRE) ⁸	Full	-26.11	-26.5	-26.87	-26.11	-26.5	-26.87	mA
Output Compliance Range	Full	-1.6; +0.1			-1.6; +0.1			V
Output Resistance	+25°C	640	800		640	800		Ω
DYNAMIC PERFORMANCE								
Update Rate	+25°C	225	250		225	250		MSPS
Output Propagation Delay ⁹	+25°C		5	6		5	6	ns
Output Settling Time ¹⁰								
Current	+25°C		8			8		ns
Voltage	+25°C		12			12		ns
Output Slew Rate ¹¹	+25°C	255	300		255	300		V/ μs
Output Rise Time ¹¹	+25°C		1.7	2.0		1.7	2.0	ns
Output Fall Time ¹¹	+25°C		1.7	2.0		1.7	2.0	ns
Glitch Impulse	+25°C		60	70		60	70	pV-s
SETUP CONTROL ¹²								
Setup Level (Grounded)	Full		0			0		IRE
Setup Level (Open)	Full		7.5			7.5		IRE
Setup Level (Tied to -5.2 V with 1 k Ω)	Full		10			10		IRE
Setup Level (-5.2 V)	Full		20			20		IRE
DIGITAL INPUTS								
Logic "1" Voltage	Full	-1.1			-1.1			V
Logic "0" Voltage	Full			-1.5			-1.5	V
Logic "1" Current	Full			100			100	μA
Logic "0" Current	Full			15			15	μA
Input Capacitance	+25°C		4	5.5		4	5.5	pF
Data Setup Time	+25°C	0.1			0.1			ns
Data Hold Time	+25°C	1.4			1.4			ns

Parameter	Temp	AD9701BQ			AD9701SQ/SE			Units
		Min	Typ	Max	Min	Typ	Max	
POWER SUPPLY ¹³								
Supply Current (-5.2 V)	+25°C		140	160		140	160	mA
	Full			160			160	mA
Nominal Power Dissipation	+25°C		728			728		mW
Power Supply Rejection Ratio ¹⁴	Full		3	6		3	6	mV/V

NOTES

¹Absolute maximum ratings are limiting values, to be applied individually, and beyond which serviceability of the circuit may be impaired. Functional operability under any of these conditions is not necessarily implied. Exposure to absolute maximum rating conditions for extended periods may affect device reliability.

²Typical thermal impedance . . .

22-Pin Ceramic $\theta_{JA} = 64^\circ\text{C/W}$; $\theta_{JC} = 16^\circ\text{C/W}$

28-Pin Ceramic LCC $\theta_{JA} = 70^\circ\text{C/W}$ $\theta_{JC} = 21^\circ\text{C/W}$

³SYNC, BLANKING, and REFERENCE WHITE are inactive (Logic "1"). $I_{SET} \approx 1.26 \text{ V/R}_{SET}$.

⁴All bits at logic HIGH.

⁵All values are relative to full-scale output, after being normalized to nominal value. Typical variation in full-scale output from device to device can reach $\pm 10\%$, for a fixed R_{SET} resistor.

⁶The effect of 10% BRIGHT algebraically adds to the output waveform.

⁷The output level with BLANKING active (Logic "0"), is determined by the setup control level.

⁸In normal operation, the BLANKING input is activated (Logic "0") prior to or in conjunction with the SYNC input. The effect of the SYNC output is relative to the setup level.

⁹Measured from edge of STROBE to 50% transition point of the output signal.

¹⁰Measured with full-scale change in output level, from the 10% transition level to within $\pm 0.2\%$ of the final output value.

¹¹Measured from 10% to 90% transition point for full-scale step output.

¹²An IRE unit is 1% of the Grey Scale (GS range) with a 0 IRE setup level.

¹³Supply Voltage should remain stable within $\pm 5\%$ for normal operation.

¹⁴Measured at $\pm 5\%$ of V_{CC} .

Specifications subject to change without notice.

DIGITAL INPUTS VS. ANALOG OUTPUT

Bit 1	Bit 2	Bit 3	Bit 4	Bit 5	Bit 6	Bit 7	Bit 8	10% Bright	Ref. White	Blanking	Comp. Sync	Analog Output (mV)
1	1	1	1	1	1	1	1	0	1	1	1	0
1	1	1	1	1	1	1	1	1	1	1	1	-71
1	0	0	0	0	0	0	0	0	1	1	1	-620
0	0	0	0	0	0	0	0	0	1	1	1	-637.5
0	0	0	0	0	0	0	0	1	1	1	1	-708.5
X	X	X	X	X	X	X	X	0	0	1	1	0
X	X	X	X	X	X	X	X	1	0	1	1	-71
X	X	X	X	X	X	X	X	0	1	0	1	-637.50 ¹
X	X	X	X	X	X	X	X	0	1	0	1	-690.75 ²
X	X	X	X	X	X	X	X	0	1	0	1	-708.50 ³
X	X	X	X	X	X	X	X	0	1	0	1	-779.50 ⁴
X	X	X	X	X	X	X	X	0	1	0	0	-922.50 ¹
X	X	X	X	X	X	X	X	0	1	0	0	-975.75 ²
X	X	X	X	X	X	X	X	0	1	0	0	-993.50 ³
X	X	X	X	X	X	X	X	0	1	0	0	-1064.50 ⁴
X	X	X	X	X	X	X	X	1	1	0	0	-993.50 ¹
X	X	X	X	X	X	X	X	1	1	0	0	-1046.75 ²
X	X	X	X	X	X	X	X	1	1	0	0	-1064.50 ³
X	X	X	X	X	X	X	X	1	1	0	0	-1135.50 ⁴

NOTES

¹Setup (Pin 21) grounded (0 IRE units).

²Setup (Pin 21) open (7.5 IRE units).

³Setup (Pin 21) to -5.2 V through 1 k (0 IRE units).

⁴Setup (Pin 21) to -5.2 V (20 IRE units).

ORDERING GUIDE

Device	Temperature Range	Description	Package Option*
AD9701BQ	-25°C to +85°C	22-Pin DIP, Industrial Temperature	Q-22
AD9701SE	-55°C to +125°C	28-Pin LCC, Extended Temperature	E-28A
AD9701SQ	-55°C to +125°C	22-Pin DIP, Extended Temperature	Q-22

*E = Leadless Ceramic Chip Carrier; Q = Cerdip.

FUNCTIONAL DESCRIPTION

Pin Name	Description										
GROUND	One of three ground returns. All grounds should be connected together near the AD9701.										
-V _S	Negative supply pin, nominally -5.2 V.										
BIT 1 (MSB)	One of eight digital input bits. BIT 1 (MSB) is the most-significant-bit of the digital input word.										
BIT 2-BIT 7	One of eight digital input bits.										
BIT 8 (LSB)	One of eight digital input bits. BIT 8 (LSB) is the least-significant-bit of the digital input word.										
STROBE	Data and control register strobe input. STROBE is leading edge triggered.										
GROUND	One of three ground returns. All grounds should be connected together near the AD9701.										
SETUP	The SETUP input determines the position of the blanking level relative to the "reference black" level (all data bits at logic "0"). The setup level is adjustable from 0 IRE units to 20 IRE units below the reference black level (an IRE unit is 1% of the "grey scale" range).										
<table border="1"> <thead> <tr> <th>SETUP LEVEL</th> <th>CONFIGURATION (PIN 21)</th> </tr> </thead> <tbody> <tr> <td>0 IRE Units</td> <td>Ground</td> </tr> <tr> <td>7.5 IRE Units</td> <td>Open</td> </tr> <tr> <td>10 IRE Units</td> <td>Connection to -5.2 V through 1 kΩ</td> </tr> <tr> <td>20 IRE Units</td> <td>Connection to -5.2 V</td> </tr> </tbody> </table>		SETUP LEVEL	CONFIGURATION (PIN 21)	0 IRE Units	Ground	7.5 IRE Units	Open	10 IRE Units	Connection to -5.2 V through 1 kΩ	20 IRE Units	Connection to -5.2 V
SETUP LEVEL	CONFIGURATION (PIN 21)										
0 IRE Units	Ground										
7.5 IRE Units	Open										
10 IRE Units	Connection to -5.2 V through 1 kΩ										
20 IRE Units	Connection to -5.2 V										
10% BRIGHT	10% BRIGHT adds an additional current to the output level, equal to roughly 10% of the "grey scale" range. The 10% BRIGHT is active logic LOW, and operates independently of all other inputs.										
COMPOSITE BLANKING	The COMPOSITE BLANKING input, active logic LOW, forces output to the blanking level set with the SETUP input.										
COMPOSITE SYNC	The COMPOSITE SYNC input, active LOW, creates a negative going horizontal synchronization pulse relative to the blanking level. Under normal operating conditions the COMPOSITE BLANKING signal should precede and extend past the COMPOSITE SYNC signal. See SETUP for additional information.										
REFERENCE WHITE	The REFERENCE WHITE input, active LOW, overrides the data inputs, and forces the output to the maximum "grey scale" level.										
COMPENSATION	The COMPENSATION input insures adequate gain stability for the internal reference amplifier. Under normal operating conditions, the COMPENSATION input is decoupled to ground through a 0.1 μF capacitor.										
CURRENT SET	The CURRENT SET input determines the full-scale or "grey scale" range. The effects of the video control functions are in addition to the "grey scale" range. ($168 \Omega \leq R_{SET} \leq 600 \Omega$). $I_{OUTmax} \approx 4 I_{SET} = 4(1.26 V/R_{SET})$										
OUTPUT	Analog output.										
GROUND	One of three ground returns. All grounds should be connected together near the AD9701.										

SYSTEM TIMING DIAGRAMS

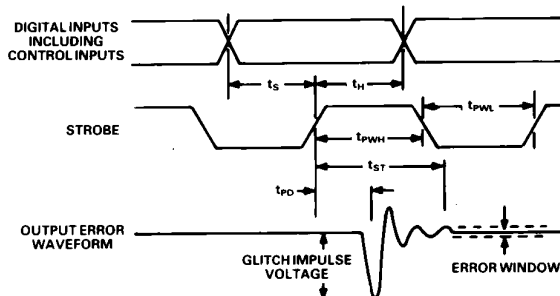
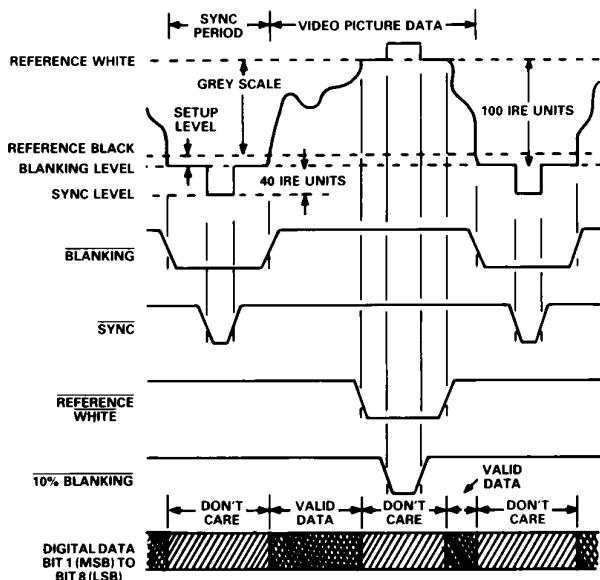

- NOTES**
 1. ALL INPUTS, INCLUDING THE VIDEO CONTROL FUNCTIONS, ARE SYNCHRONIZED TO THE STROBE INPUT.
 2. THE 10% BRIGHT CONTROL WILL INCREASE THE OUTPUT LEVEL BY APPROXIMATELY 10 IRE UNITS OVER THE PRESENT OUTPUT LEVEL.
 3. AN IRE UNIT IS IDEALLY 7.14mV.

DIE LAYOUT AND MECHANICAL INFORMATION

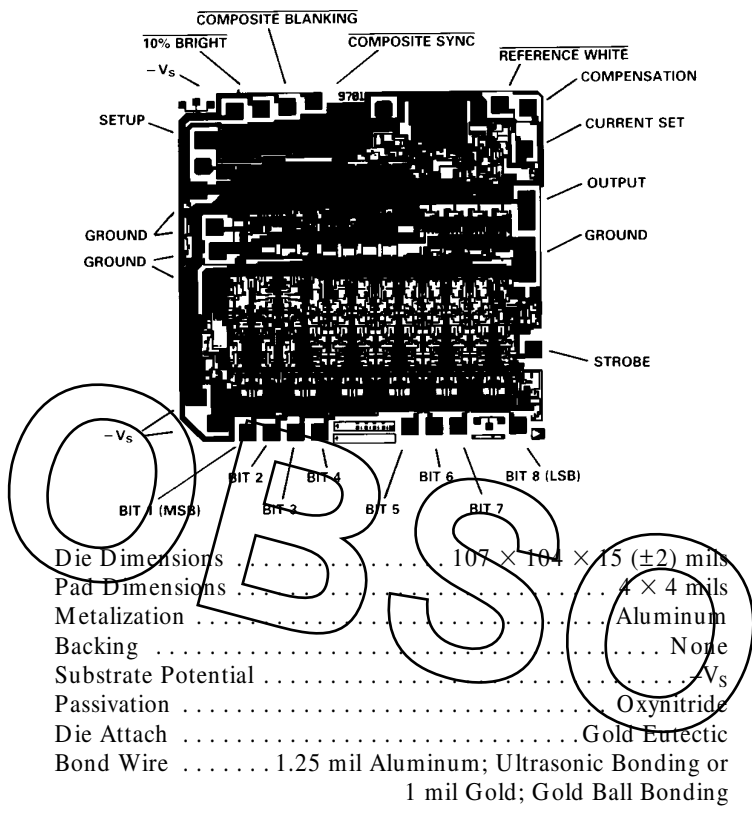

APPLICATIONS INFORMATION

Raster scan video displays image data on a line by line basis, with timing and control signals inserted between the lines. The control signals include the horizontal synchronization pulses which are used to align the display circuitry at the beginning of each line. After the complete video image is displayed on the monitor, the process begins again with the next image. The vertical reset pulse(s) that initiate this timing sequence are located between each video image.

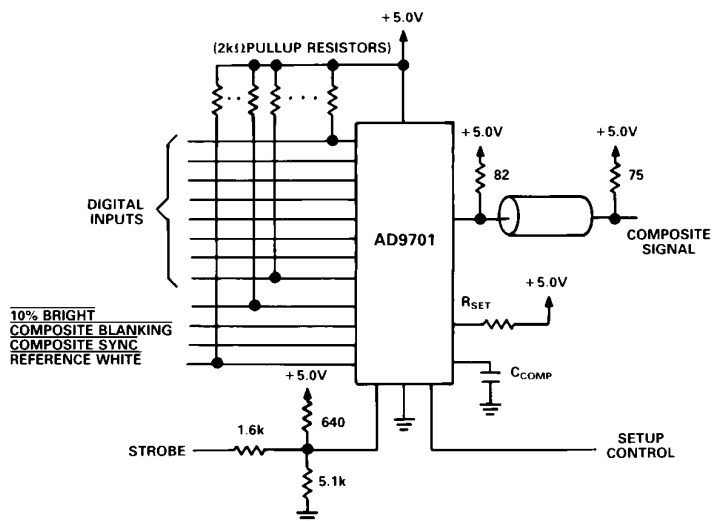

Raster Graphics Configuration for TTL Systems

The image data is distinguished from the timing information by its location relative to the blanking level. The blanking reference level is at the blackest extreme of the image data, and all timing

signals are designed to fall below the blanking level so as not to be seen on the monitor. The actual image data is located above the blanking level, and it may be further separated from the timing signal by the setup level. The setup level is simply a buffer zone between the timing and image data.

Generation of the timing signals for the AD9701 is controlled by the COMPOSITE BLANKING and the COMPOSITE SYNC inputs. In normal operation the output level of the AD9701 is forced to the blanking level (black) with the COMPOSITE BLANKING control so that when the synchronization occurs, it will not interfere (be seen) with the monitor image. The COMPOSITE SYNC control forces the output level below the blanking level, generating the synchronization pulse.

The “grey scale” is the image intensity range, located above the blanking level by the amount of the setup level. The setup level is “reference black,” the darkest displayable picture intensity. The top of the “grey scale” is “reference white,” or the brightest picture intensity. As an 8-bit device, the AD9701 divides the “gray scale” into 256 individual levels.

Normal raster scan waveforms divide the region between the blanking level and reference white into 100 IRE units (International Radio Engineers). The setup level can range from 0 to 20 IRE units, but typically is around 10 IRE units, and the synchronization pulse level typically falls 40 IRE units below the blanking level. For the AD9701, the reference white level is 10 IRE units below the full-scale output range (0 mA_{OUT}).

In terms of priority, the REFERENCE WHITE control overrides the data inputs, but both COMPOSITE SYNC and COMPOSITE BLANKING override the data inputs and the REFERENCE WHITE control. A fourth control is active at all times, 10% BRIGHT, which adds approximately 10 IRE units to the output level no matter what the input state of the AD9701. The 10% BRIGHT control is primarily used to high-light areas of the video image.

As with any high-speed device, the AD9701 requires a substantial low impedance ground plane and high quality ground connections to achieve the best performance. Performance can also be improved with adequate power supply decoupling near the supply pins of the AD9701. In ECL mode, the output of the AD9701 is designed to drive 75 Ω cable directly, with 75 Ω terminations to ground at both ends of the cable. For TTL configurations the output should be terminated to +5.0 V through an 82 Ω resistor (see circuit below).

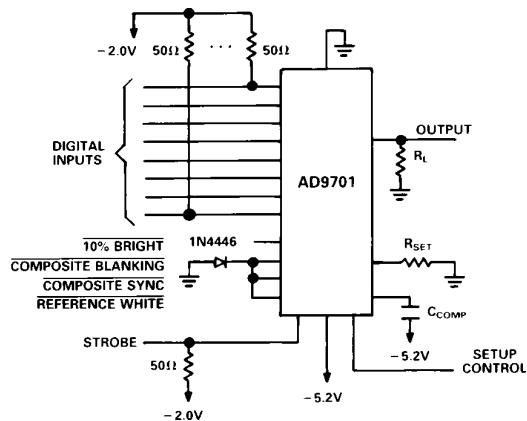

Standard Reconstruction Configuration

OUTLINE DIMENSIONS
 Dimensions shown in inches and (mm).

22-Pin Side-Brazed DIP

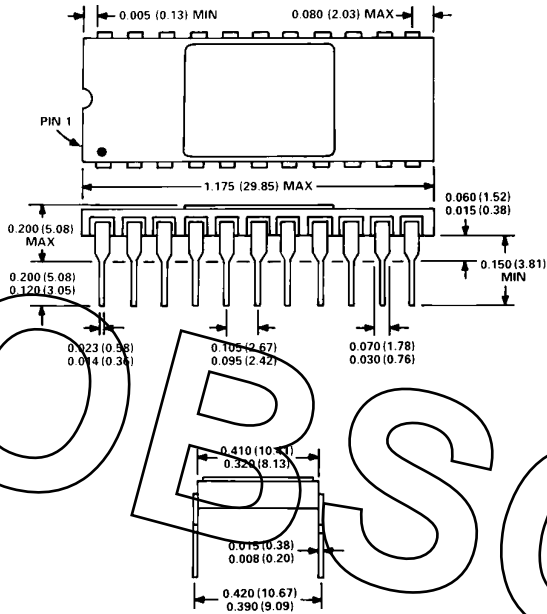

22-Pin Ceramic DIP

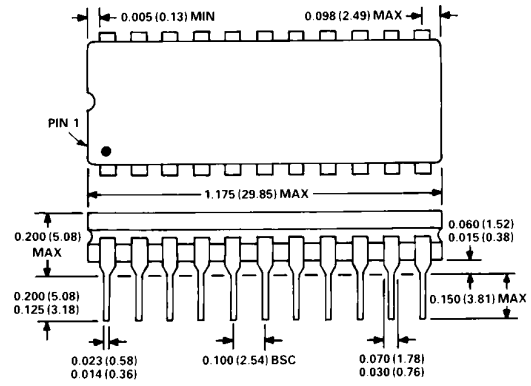

28-Pin LCC

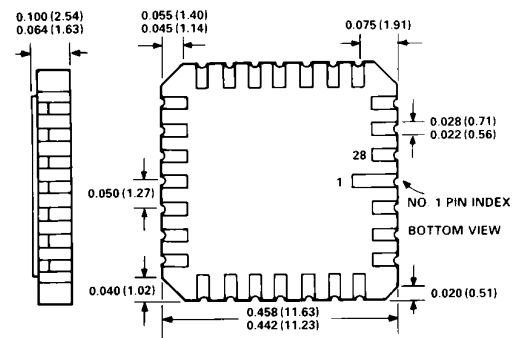

- NOTES**
1. THIS DIMENSION CONTROLS THE OVERALL PACKAGE THICKNESS.
 2. APPLIES TO ALL FOUR SIDES.
 3. ALL TERMINALS ARE GOLD PLATED.

OBSOLETE