

© 1969 BY AMP INCORPORATED. ALL RIGHTS RESERVED. AMP PRODUCTS COVERED BY PATENTS AND/OR PATENTS PENDING.

REVISIONS				
ZONE	LTR	DESCRIPTION	DATE	APPROVED
✓	0	REL, WAS 5155-76 (Cp17)	RHF 3-17-69	

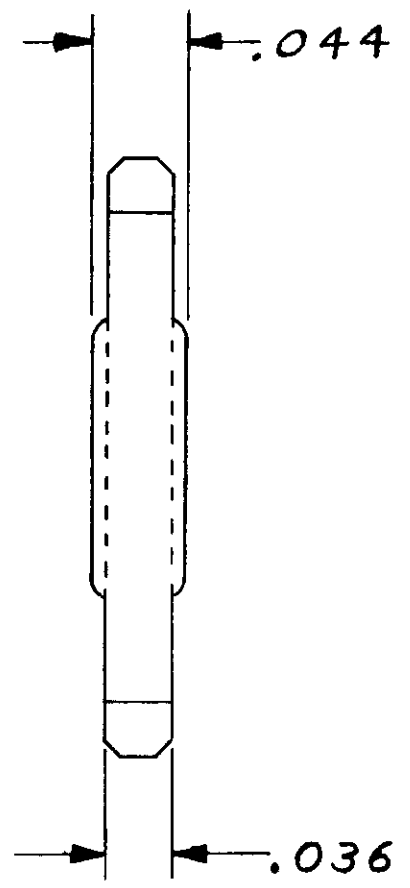
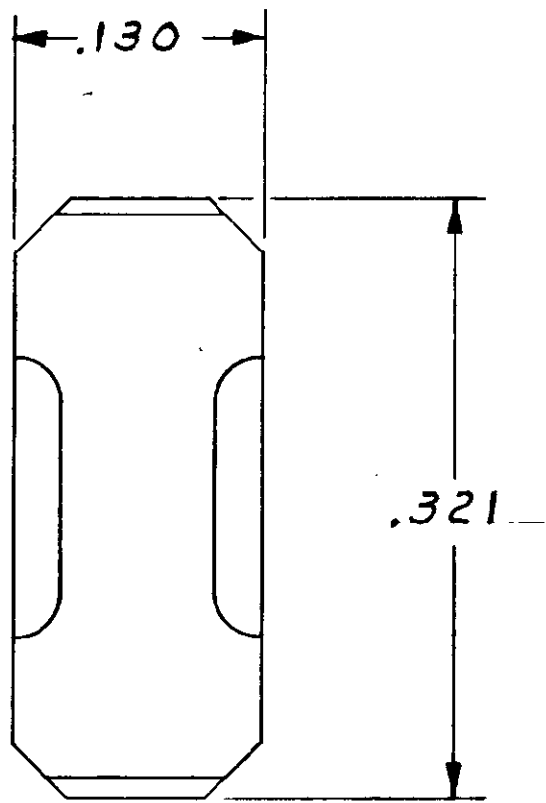

583462-1: I.A.S SHOWN

△. MATL. NYLON  
COLOR: NATURAL

LOC AD  
PART DIST 0/14

UNLESS OTHERWISE SPECIFIED DIMENSIONS ARE IN INCHES TOLERANCES ON: DECIMALS ±.005 ANGLES ±	CONTRACT NO.		AMP INCORPORATED HARRISBURG, PENNSYLVANIA	
	DR. <i>M. Smith</i> 1-22-69	NAME PLUG-KEYING, MODIFIED FORK CONNECTOR		
	CHK. <i>Stute</i> 3/10/69			
	MATERIAL △	APPD. <i>J. Kaufman</i> 3/19/69	SIZE <b>B</b>	CODE IDENT NO. 00779
	REC. <i>R. Shawan</i> 3/21/69	SCALE 10-1	SHEET	
	DSGN APPD	OTHER APPD		