

550MHz Differential Twisted-Pair Driver

The EL5177 is a high bandwidth amplifier with an output in differential form. It is primarily targeted for applications such as driving twisted-pair lines or any application where common mode injection is likely to occur. The input signal can be in either single-ended or differential form but the output is always in differential form.

On the EL5177, two feedback inputs provide the user with the ability to set the device gain (stable at minimum gain of one.)

The output common mode level is set by the reference pin (REF), which has a -3dB bandwidth of 110MHz. Generally, this pin is grounded but it can be tied to any voltage reference.

Both outputs (OUT+, OUT-) are short circuit protected to withstand temporary overload condition.

The EL5177 is available in the 10 Ld MSOP package and is specified for operation over the full -40°C to +85°C temperature range.

See also EL5174 (EL5177 in 8 Ld MSOP.)

Features

- Fully differential inputs, outputs, and feedback
- Differential input range $\pm 2.3V$
- 550MHz 3dB bandwidth
- 1100V/ μs slew rate
- Low distortion at 20MHz
- Single 5V or dual $\pm 5V$ supplies
- 40mA maximum output current
- Low power, 12.5mA typical supply current
- Pb-free plus anneal available (RoHS compliant)

Applications

- Twisted-pair drivers
- Differential line drivers
- VGA over twisted-pair
- ADSL/HDSL drivers
- Single ended to differential amplification
- Transmission of analog signals in a noisy environment

Pinout

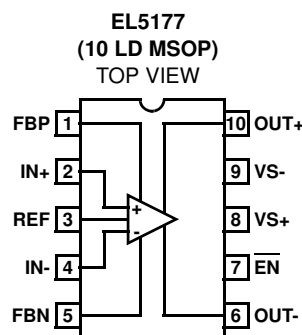

Ordering Information

PART NUMBER	PART MARKING	TAPE & REEL	PACKAGE	PKG. DWG. #
EL5177IY	3	-	10 Ld MSOP (3.0mm)	MDP0043
EL5177IY-T7	3	7"	10 Ld MSOP (3.0mm)	MDP0043
EL5177IY-T13	3	13"	10 Ld MSOP (3.0mm)	MDP0043
EL5177IYZ (Note)	BAAKA	-	10 Ld MSOP (Pb-free) (3.0mm)	MDP0043
EL5177IYZ-T7 (Note)	BAAKA	7"	10 Ld MSOP (Pb-free) (3.0mm)	MDP0043
EL5177IYZ-T13 (Note)	BAAKA	13"	10 Ld MSOP (Pb-free) (3.0mm)	MDP0043

NOTE: Intersil Pb-free plus anneal products employ special Pb-free material sets; molding compounds/die attach materials and 100% matte tin plate termination finish, which are RoHS compliant and compatible with both SnPb and Pb-free soldering operations. Intersil Pb-free products are MSL classified at Pb-free peak reflow temperatures that meet or exceed the Pb-free requirements of IPC/JEDEC J STD-020.

Absolute Maximum Ratings ($T_A = +25^{\circ}\text{C}$)

Supply Voltage (V_{S+} to V_{S-})12V
 Maximum Output Current. $\pm 60\text{mA}$
 V_{IN} , V_{INB} , V_{REF} $V_{S-} + 0.8\text{V}$ (min) to $V_{S+} - 0.8\text{V}$ (max)
 $V_{IN} - V_{INB}$ ± 5

Thermal Information

Recommended Operating Temperature -40°C to $+85^{\circ}\text{C}$
 Operating Junction Temperature $+135^{\circ}\text{C}$
 Storage Temperature Range -65°C to $+150^{\circ}\text{C}$
 Pb-free reflow profile see link below
<http://www.intersil.com/pbfree/Pb-FreeReflow.asp>

CAUTION: Stresses above those listed in "Absolute Maximum Ratings" may cause permanent damage to the device. This is a stress only rating and operation of the device at these or any other conditions above those indicated in the operational sections of this specification is not implied.

IMPORTANT NOTE: All parameters having Min/Max specifications are guaranteed. Typ values are for information purposes only. Unless otherwise noted, all tests are at the specified temperature and are pulsed tests, therefore: $T_J = T_C = T_A$

Electrical Specifications $V_{S+} = +5\text{V}$, $V_{S-} = -5\text{V}$, $T_A = +25^{\circ}\text{C}$, $V_{IN} = 0\text{V}$, $R_{LD} = 1\text{k}\Omega$, $R_F = 0$, $R_G = \text{OPEN}$, $C_{LD} = 2.7\text{pF}$, Unless Otherwise Specified.

PARAMETER	DESCRIPTION	CONDITIONS	MIN	TYP	MAX	UNIT
AC PERFORMANCE						
BW	-3dB Bandwidth	$A_V = 1$, $C_{LD} = 2.7\text{pF}$		550		MHz
		$A_V = 2$, $R_F = 500$, $C_{LD} = 2.7\text{pF}$		130		MHz
		$A_V = 10$, $R_F = 500$, $C_{LD} = 2.7\text{pF}$		20		MHz
BW	$\pm 0.1\text{dB}$ Bandwidth	$A_V = 1$, $C_{LD} = 2.7\text{pF}$		120		MHz
SR	Slew Rate	$V_{OUT} = 3\text{V}_{P-P}$, 20% to 80%	800	1100		$\text{V}/\mu\text{s}$
t_{STL}	Settling Time to 0.1%	$V_{OUT} = 2\text{V}_{P-P}$		10		ns
t_{OVR}	Output Overdrive Recovery Time			20		ns
GBWP	Gain Bandwidth Product			200		MHz
V_{REFBW} (-3dB)	V_{REF} -3dB Bandwidth	$A_V = 1$, $C_{LD} = 2.7\text{pF}$		110		MHz
V_{REFSR+}	V_{REF} Slew Rate - Rise	$V_{OUT} = 2\text{V}_{P-P}$, 20% to 80%		134		$\text{V}/\mu\text{s}$
V_{REFSR-}	V_{REF} Slew Rate - Fall	$V_{OUT} = 2\text{V}_{P-P}$, 20% to 80%		70		$\text{V}/\mu\text{s}$
V_N	Input Voltage Noise	at 10kHz		21		$\text{nV}/\sqrt{\text{Hz}}$
I_N	Input Current Noise	at 10kHz		2.7		$\text{pA}/\sqrt{\text{Hz}}$
HD2	Second Harmonic Distortion	$V_{OUT} = 2\text{V}_{P-P}$, 5MHz		-95		dBc
		$V_{OUT} = 2\text{V}_{P-P}$, 20MHz		-94		dBc
HD3	Third Harmonic Distortion	$V_{OUT} = 2\text{V}_{P-P}$, 5MHz		-88		dBc
		$V_{OUT} = 2\text{V}_{P-P}$, 20MHz		-87		dBc
dG	Differential Gain at 3.58MHz	$R_{LD} = 300\Omega$, $A_V = 2$		0.06		%
d θ	Differential Phase at 3.58MHz	$R_{LD} = 300\Omega$, $A_V = 2$		0.13		$^{\circ}$
INPUT CHARACTERISTICS						
V_{OS}	Input Referred Offset Voltage			± 1.4	± 25	mV
I_{IN}	Input Bias Current (V_{IN+} , V_{IN-})		-30	-14	-7	μA
I_{REF}	Input Bias Current (V_{REF})		0.5	2.3	4	μA
R_{IN}	Differential Input Resistance			150		$\text{k}\Omega$
C_{IN}	Differential Input Capacitance			1		pF
DMIR	Differential Mode Input Range		± 2.1	± 2.3	± 2.5	V
CMIR+	Common Mode Positive Input Range at V_{IN+} , V_{IN-}			3.4		V
CMIR-	Common Mode Negative Input Range at V_{IN+} , V_{IN-}			-4.3		V
V_{REFIN+}	Positive Reference Input Voltage Range	$V_{IN+} = V_{IN-} = 0\text{V}$	3.4	3.7		V

EL5177

Electrical Specifications $V_{S+} = +5V$, $V_{S-} = -5V$, $T_A = +25^\circ C$, $V_{IN} = 0V$, $R_{LD} = 1k\Omega$, $R_F = 0$, $R_G = OPEN$, $C_{LD} = 2.7pF$, Unless Otherwise Specified. **(Continued)**

PARAMETER	DESCRIPTION	CONDITIONS	MIN	TYP	MAX	UNIT
V_{REFIN-}	Negative Reference Input Voltage Range	$V_{IN+} = V_{IN-} = 0V$		-3.3	-3	V
V_{REFOS}	Output Offset Relative to V_{REF}			± 50	± 100	mV
CMRR	Input Common Mode Rejection Ratio	$V_{IN} = \pm 2.5V$	65	78		dB
Gain	Gain Accuracy	$V_{IN} = 1V$	0.980	0.995	1.010	V
OUTPUT CHARACTERISTICS						
V_{OUT}	Output Voltage Swing	$R_L = 500\Omega$ to GND	± 3.6	± 3.8		V
$I_{OUT+}(Max)$	Maximum Source Output Current	$R_L = 10\Omega$, $V_{IN+} = 1.1V$, $V_{IN-} = -1.1V$, $V_{REF} = 0$	35	50		mA
$I_{OUT-}(Max)$	Maximum Sink Output Current			-40	-30	mA
R_{OUT}	Output Impedance			130		$m\Omega$
SUPPLY						
V_{SUPPLY}	Supply Operating Range	V_{S+} to V_{S-}	4.75		11	V
$I_{S(ON)}$	Power Supply Current - Per Channel		10	12.5	14	mA
$I_{S(OFF)+}$	Positive Power Supply Current - Disabled	\overline{EN} pin tied to 4.8V		76	120	μA
$I_{S(OFF)-}$	Negative Power Supply Current - Disabled		-200	-120		μA
PSRR	Power Supply Rejection Ratio	V_S from $\pm 4.5V$ to $\pm 5.5V$	60	75		dB
ENABLE						
t_{EN}	Enable Time			130		ns
t_{DS}	Disable Time			1.2		μs
V_{IH}	\overline{EN} Pin Voltage for Power-Up				$V_{S+} - 1.5$	V
V_{IL}	\overline{EN} Pin Voltage for Shut-Down		$V_{S+} - 0.5$			V
I_{IH-EN}	\overline{EN} Pin Input Current High	At $V_{EN} = 5V$		40	50	μA
I_{IL-EN}	\overline{EN} Pin Input Current Low	At $V_{EN} = 0V$	-6	-2.5		μA

Pin Descriptions

PIN NUMBER	PIN NAME	PIN DESCRIPTION
1	FBP	Non-inverting feedback input; resistor R_{F1} must be connected from this pin to V_{OUT}
2	IN+	Non-inverting input
3	REF	Output common-mode control; the common-mode voltage of V_{OUT} will follow the voltage on this pin
4	IN-	Inverting input
5	FBN	Inverting feedback input; resistor R_{F2} must be connected from this pin to V_{OUT}
6	OUT-	Inverting output
7	\overline{EN}	Enabled when this pin is floating or the applied voltage $\leq V_{S+} - 1.5$
8	V_{S+}	Positive supply
9	V_{S-}	Negative supply
10	OUT+	Non-inverting output

Connection Diagram

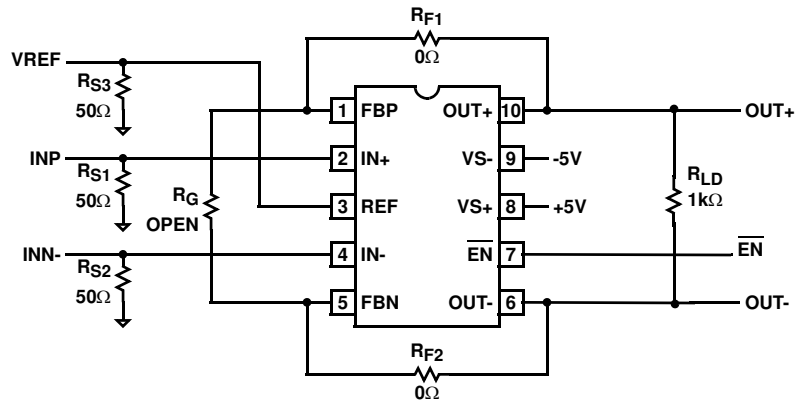

Typical Performance Curves

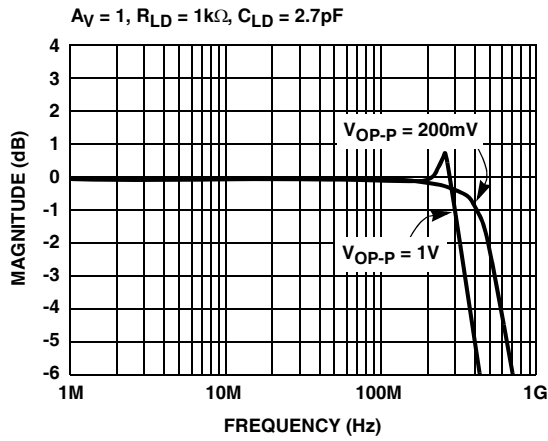

FIGURE 1. FREQUENCY RESPONSE

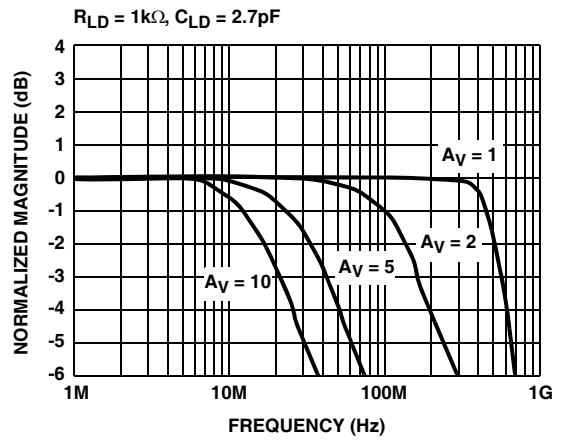

FIGURE 2. FREQUENCY RESPONSE FOR VARIOUS GAIN

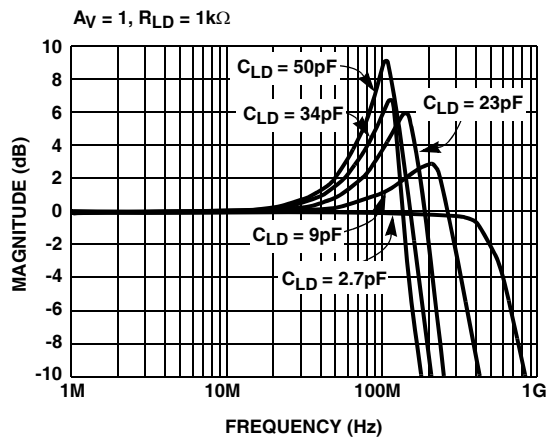

FIGURE 3. FREQUENCY RESPONSE vs C_{LD}

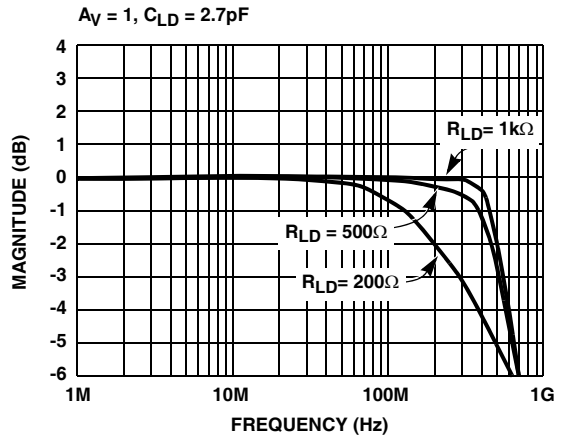

FIGURE 4. FREQUENCY RESPONSE vs R_{LD}

Typical Performance Curves (Continued)

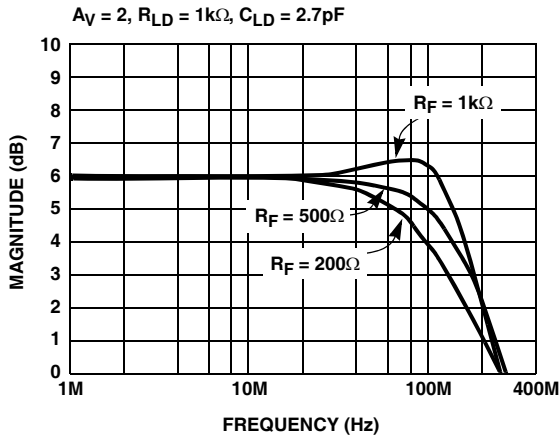

FIGURE 5. FREQUENCY RESPONSE

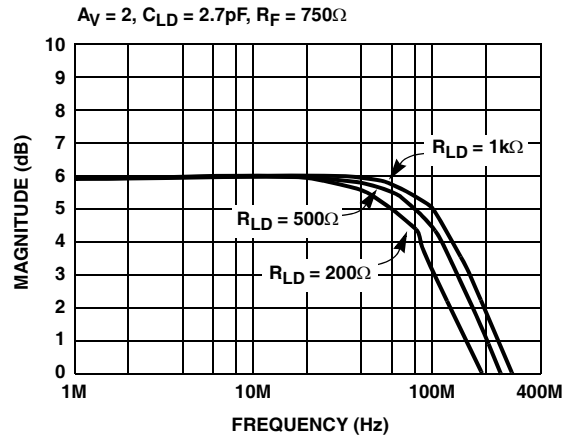

FIGURE 6. FREQUENCY RESPONSE vs R_{LD}

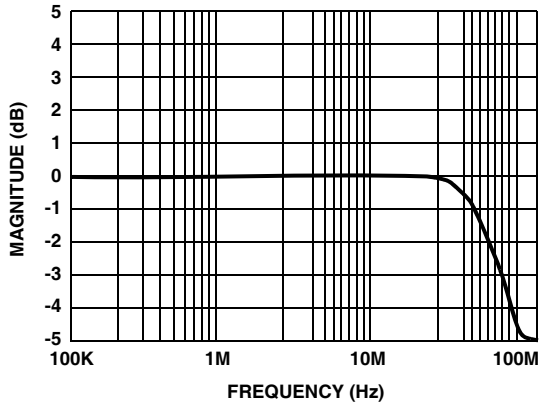

FIGURE 7. FREQUENCY RESPONSE - V_{REF}

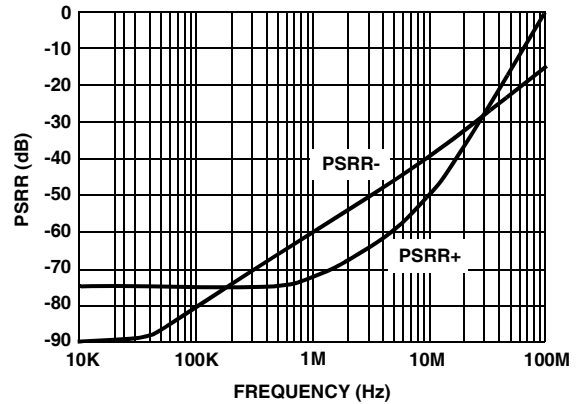

FIGURE 8. PSRR vs FREQUENCY

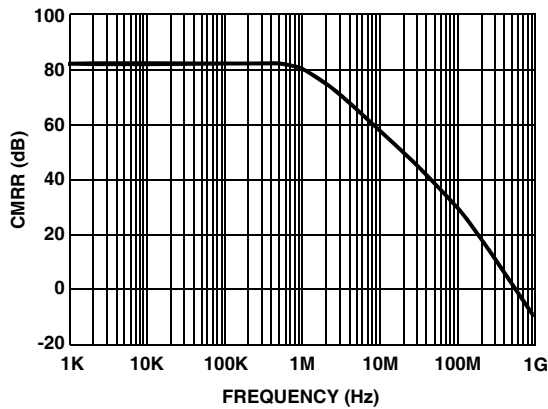

FIGURE 9. CMRR vs FREQUENCY

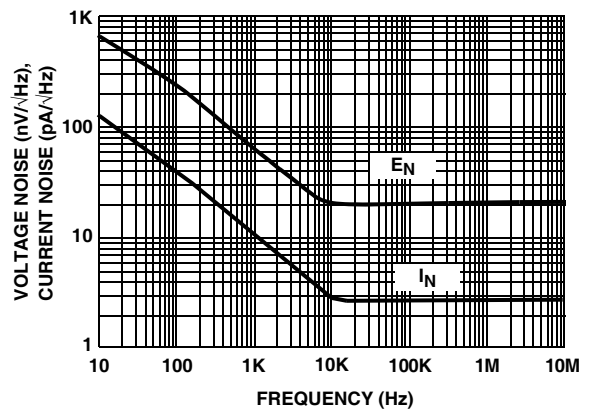

FIGURE 10. VOLTAGE AND CURRENT NOISE vs FREQUENCY

Typical Performance Curves (Continued)

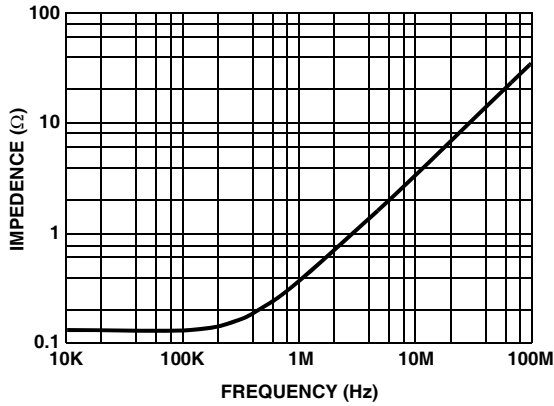

FIGURE 11. OUTPUT IMPEDANCE vs FREQUENCY

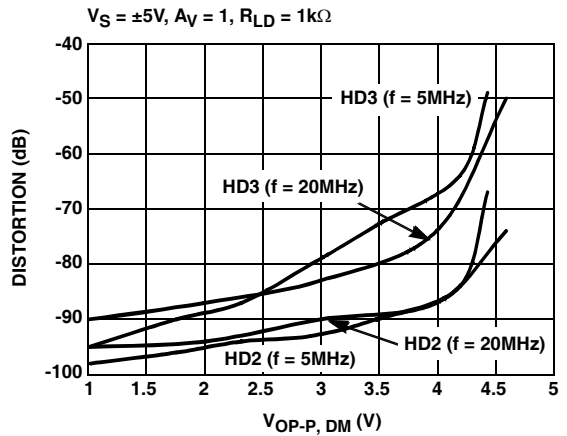

FIGURE 12. HARMONIC DISTORTION vs DIFFERENTIAL OUTPUT VOLTAGE

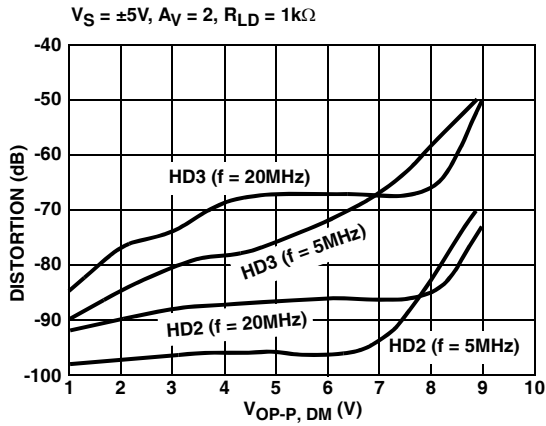

FIGURE 13. HARMONIC DISTORTION vs DIFFERENTIAL OUTPUT VOLTAGE

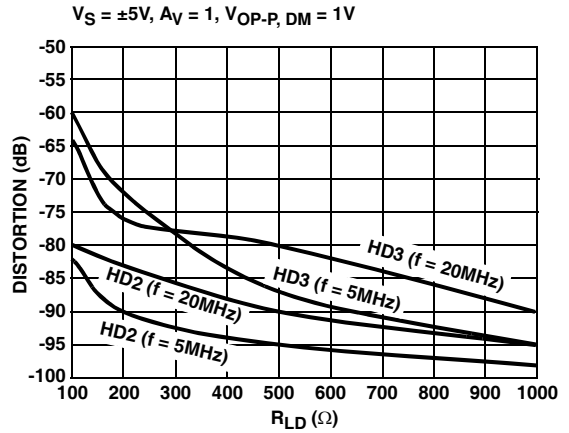

FIGURE 14. HARMONIC DISTORTION vs R_{LD}

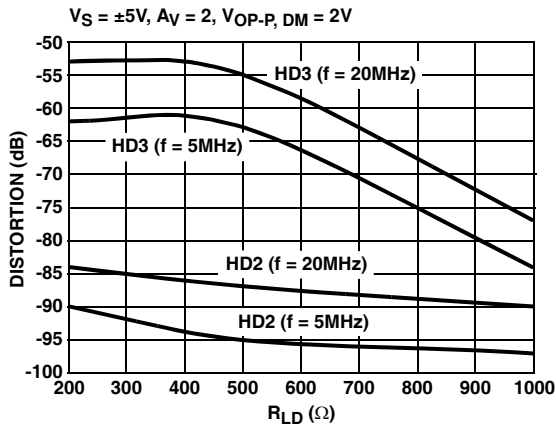

FIGURE 15. HARMONIC DISTORTION vs R_{LD}

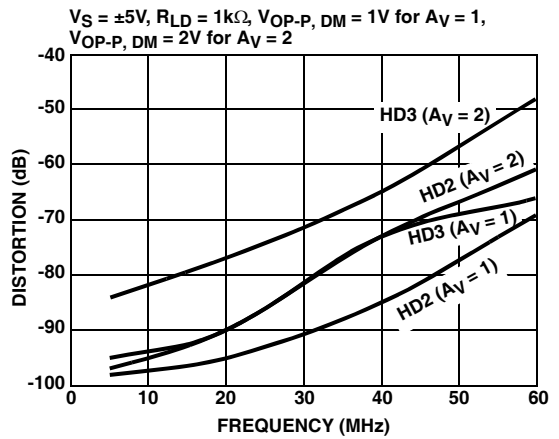

FIGURE 16. HARMONIC DISTORTION vs FREQUENCY

Typical Performance Curves (Continued)

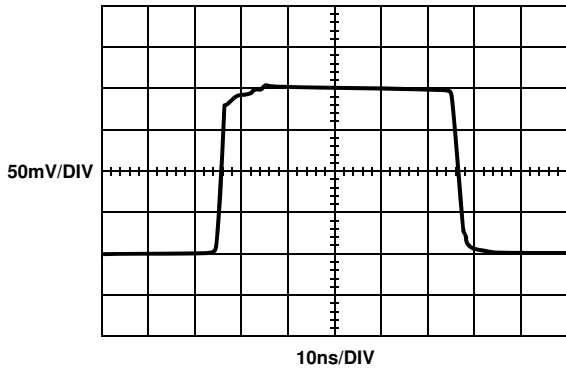

FIGURE 17. SMALL SIGNAL TRANSIENT RESPONSE

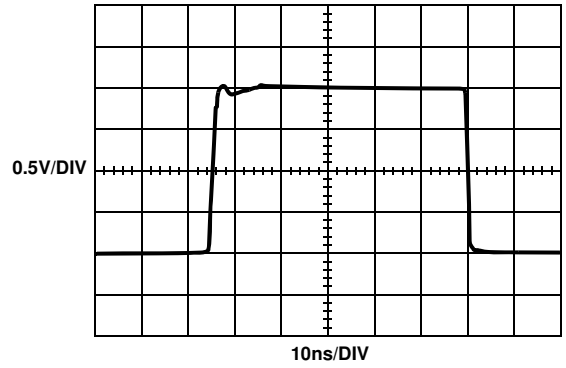

FIGURE 18. LARGE SIGNAL TRANSIENT RESPONSE

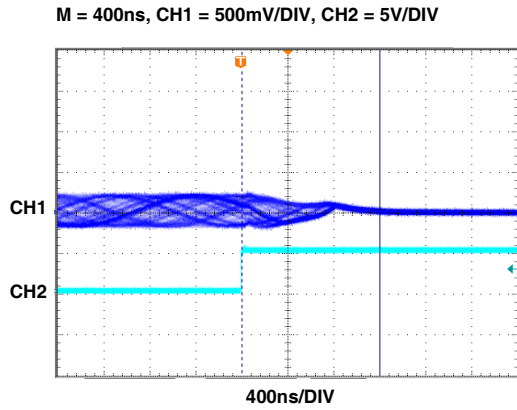

FIGURE 19. ENABLED RESPONSE

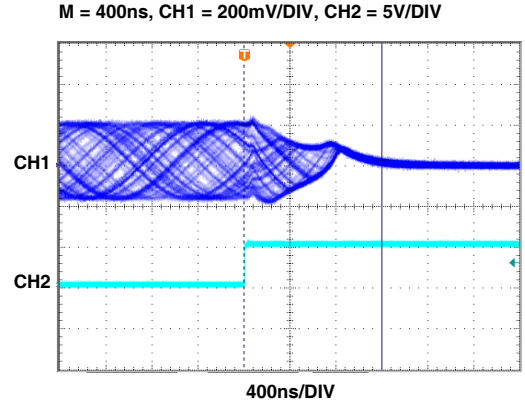

FIGURE 20. DISABLED RESPONSE

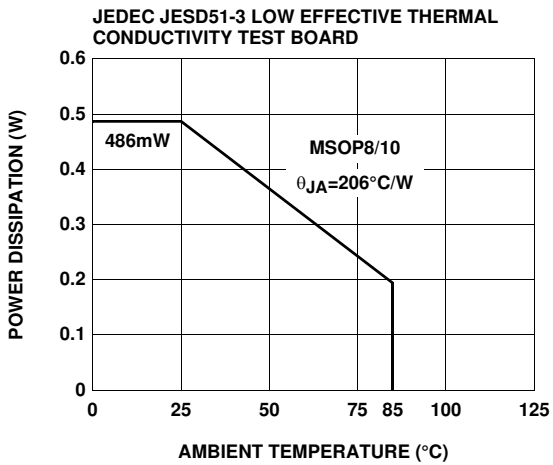

FIGURE 21. PACKAGE POWER DISSIPATION vs AMBIENT TEMPERATURE

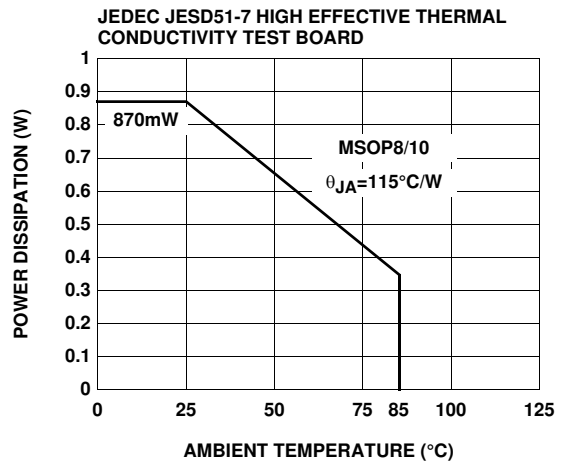
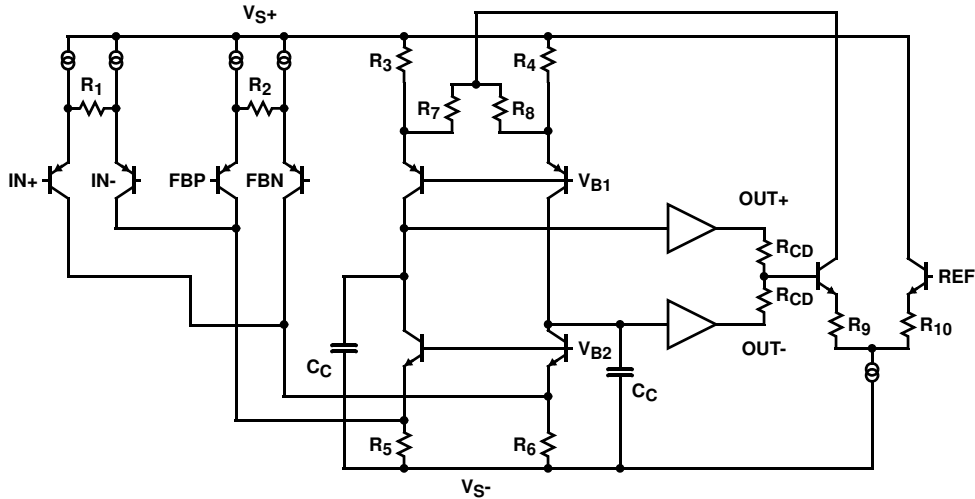

FIGURE 22. PACKAGE POWER DISSIPATION vs AMBIENT TEMPERATURE

Simplified Schematic



Description of Operation and Application Information

Product Description

The EL5177 is a wide bandwidth, low power and single/differential ended to differential output amplifier. It can be used as single/differential ended to differential converter. The EL5177 is internally compensated for closed loop gain of +1 of greater. Connected in gain of 1 and driving a 1kΩ differential load, the EL5177 has a -3dB bandwidth of 550MHz. Driving a 200Ω differential load at gain of 2, the bandwidth is about 130MHz. The EL5177 is available with a power down feature to reduce the power while the amplifier is disabled.

Input, Output, and Supply Voltage Range

The EL5177 has been designed to operate with a single supply voltage of 5V to 10V or a split supplies with its total voltage from 5V to 10V. The amplifiers have an input common mode voltage range from -4.3V to 3.4V for ±5V supply. The differential mode input range (DMIR) between the two inputs is from -2.3V to +2.3V. The input voltage range at the REF pin is from -3.3V to 3.7V. If the input common mode or differential mode signal is outside the above-specified ranges, it will cause the output signal distorted.

The output of the EL5177 can swing from -3.8V to +3.8V at 1kΩ differential load at ±5V supply. As the load resistance becomes lower, the output swing is reduced.

Differential and Common Mode Gain Settings

The voltage applied at REF pin can set the output common mode voltage and the gain is one. The differential gain is set by the R_F and R_G network.

The gain setting for EL5177 is:

$$V_{ODM} = (V_{IN+} - V_{IN-}) \times \left(1 + \frac{R_{F1} + R_{F2}}{R_G}\right)$$

$$V_{ODM} = (V_{IN+} - V_{IN-}) \times \left(1 + \frac{2R_F}{R_G}\right)$$

$$V_{OCM} = V_{REF}$$

Where:

$$R_{F1} = R_{F2} = R_F$$

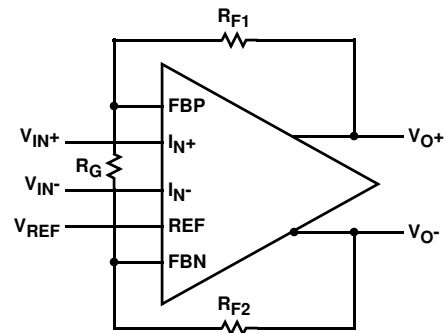

FIGURE 23.

Choice of Feedback Resistor and Gain Bandwidth Product

For applications that require a gain of +1, no feedback resistor is required. Just short the OUT+ pin to FBP pin and OUT- pin to FBN pin. For gains greater than +1, the feedback resistor forms a pole with the parasitic capacitance at the inverting input. As this pole becomes smaller, the amplifier's phase margin is reduced. This causes ringing in the time domain and peaking in the frequency domain. Therefore, R_F has some maximum value that should not be exceeded for optimum performance. If a large value of R_F

must be used, a small capacitor in the few Pico farad range in parallel with R_F can help to reduce the ringing and peaking at the expense of reducing the bandwidth.

The bandwidth of the EL5177 depends on the load and the feedback network. R_F and R_G appear in parallel with the load for gains other than +1. As this combination gets smaller, the bandwidth falls off. Consequently, R_F also has a minimum value that should not be exceeded for optimum bandwidth performance. For gain of +1, $R_F = 0$ is optimum. For the gains other than +1, optimum response is obtained with R_F between 500Ω to $1k\Omega$.

The EL5177 has a gain bandwidth product of 200MHz for $R_{LD} = 1k\Omega$. For gains ≥ 5 , its bandwidth can be predicted by the following equation:

$$\text{Gain} \times \text{BW} = 200\text{MHz}$$

Driving Capacitive Loads and Cables

The EL5177 can drive 23pF differential capacitor in parallel with $1k\Omega$ differential load with less than 5dB of peaking at gain of +1. If less peaking is desired in applications, a small series resistor (usually between 5Ω to 50Ω) can be placed in series with each output to eliminate most peaking. However, this will reduce the gain slightly. If the gain setting is greater than 1, the gain resistor R_G can then be chosen to make up for any gain loss which may be created by the additional series resistor at the output.

When used as a cable driver, double termination is always recommended for reflection-free performance. For those applications, a back-termination series resistor at the amplifier's output will isolate the amplifier from the cable and allow extensive capacitive drive. However, other applications may have high capacitive loads without a back-termination resistor. Again, a small series resistor at the output can help to reduce peaking.

Disable/Power-Down

The EL5177 can be disabled and placed its outputs in a high impedance state. The turn off time is about $1.2\mu\text{s}$ and the turn on time is about 130ns. When disabled, the amplifier's supply current is reduced to $1.7\mu\text{A}$ for I_{S+} and $120\mu\text{A}$ for I_{S-} typically, thereby effectively eliminating the power consumption. The amplifier's power down can be controlled by standard CMOS signal levels at the EN pin. The applied logic signal is relative to V_{S+} pin. Letting the $\overline{\text{EN}}$ pin float or applying a signal that is less than 1.5V below V_{S+} will enable the amplifier. The amplifier will be disabled when the signal at $\overline{\text{EN}}$ pin is above $V_{S+} - 0.5\text{V}$.

Output Drive Capability

The EL5177 has internal short circuit protection. Its typical short circuit current is $\pm 40\text{mA}$. If the output is shorted indefinitely, the power dissipation could easily increase such that the part will be destroyed. Maximum reliability is

maintained if the output current never exceeds $\pm 40\text{mA}$. This limit is set by the design of the internal metal interconnect.

Power Dissipation

With the high output drive capability of the EL5177. It is possible to exceed the 135°C absolute maximum junction temperature under certain load current conditions. Therefore, it is important to calculate the maximum junction temperature for the application to determine if the load conditions or package types need to be modified for the amplifier to remain in the safe operating area.

The maximum power dissipation allowed in a package is determined according to:

$$PD_{\text{MAX}} = \frac{T_{\text{JMAX}} - T_{\text{AMAX}}}{\theta_{\text{JA}}}$$

Where:

T_{JMAX} = Maximum junction temperature

T_{AMAX} = Maximum ambient temperature

θ_{JA} = Thermal resistance of the package

The maximum power dissipation actually produced by an IC is the total quiescent supply current times the total power supply voltage, plus the power in the IC due to the load, or:

$$PD = V_S \times I_{\text{SMAX}} + V_S \times \frac{\Delta V_O}{R_{LD}}$$

Where:

V_S = Total supply voltage

I_{SMAX} = Maximum quiescent supply current per channel

ΔV_O = Maximum differential output voltage of the application

R_{LD} = Differential load resistance

I_{LOAD} = Load current

By setting the two PD_{MAX} equations equal to each other, we can solve the output current and R_{LD} to avoid the device overheat.

Power Supply Bypassing and Printed Circuit Board Layout

As with any high frequency device, a good printed circuit board layout is necessary for optimum performance. Lead lengths should be as short as possible. The power supply pin must be well bypassed to reduce the risk of oscillation. For normal single supply operation, where the V_{S-} pin is connected to the ground plane, a single $4.7\mu\text{F}$ tantalum capacitor in parallel with a $0.1\mu\text{F}$ ceramic capacitor from V_{S+} to GND will suffice. This same capacitor combination should be placed at each supply pin to ground if split supplies are to

be used. In this case, the V_S - pin becomes the negative supply rail.

For good AC performance, parasitic capacitance should be kept to minimum. Use of wire wound resistors should be avoided because of their additional series inductance. Use of sockets should also be avoided if possible. Sockets add

parasitic inductance and capacitance that can result in compromised performance. Minimizing parasitic capacitance at the amplifier's inverting input pin is very important. The feedback resistor should be placed very close to the inverting input pin. Strip line design techniques are recommended for the signal traces.

Typical Applications

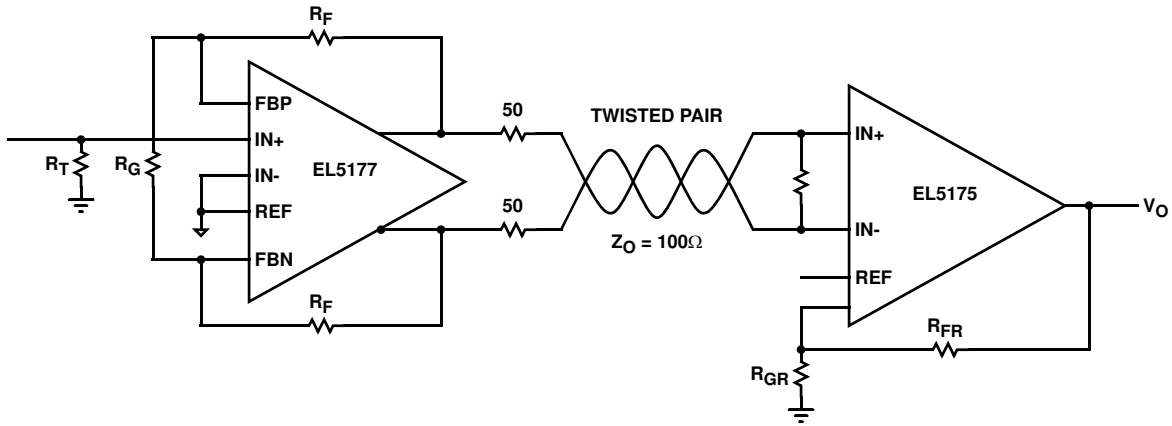
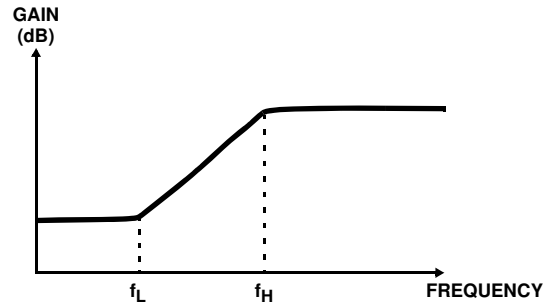
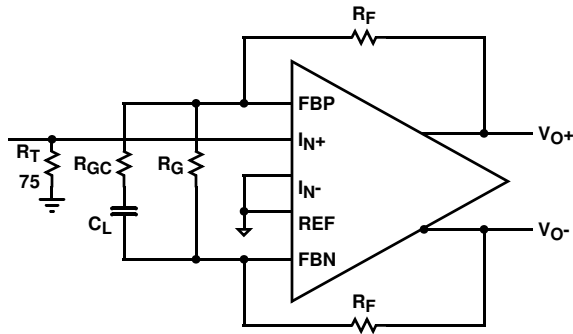

FIGURE 24. TWISTED PAIR CABLE RECEIVER

As the signal is transmitted through a cable, the high frequency signal will be attenuated. One way to compensate this loss is to boost the high frequency gain at the receiver side.



$$\text{DC Gain} = 1 + \frac{2R_F}{R_G}$$

$$\text{(HF)Gain} = 1 + \frac{2R_F}{R_G \parallel R_{GC}}$$

$$f_L \cong \frac{1}{2\pi R_G C_C}$$

$$f_H \cong \frac{1}{2\pi R_{GC} C_C}$$

FIGURE 25. TRANSMIT EQUALIZER

Mini SO Package Family (MSOP)

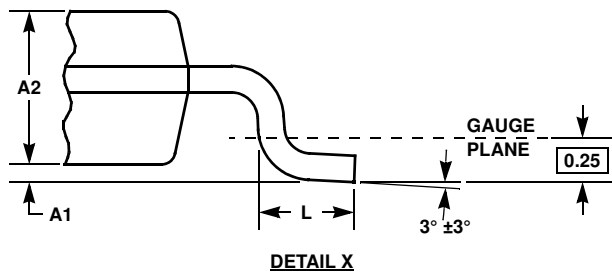
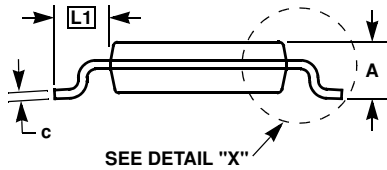
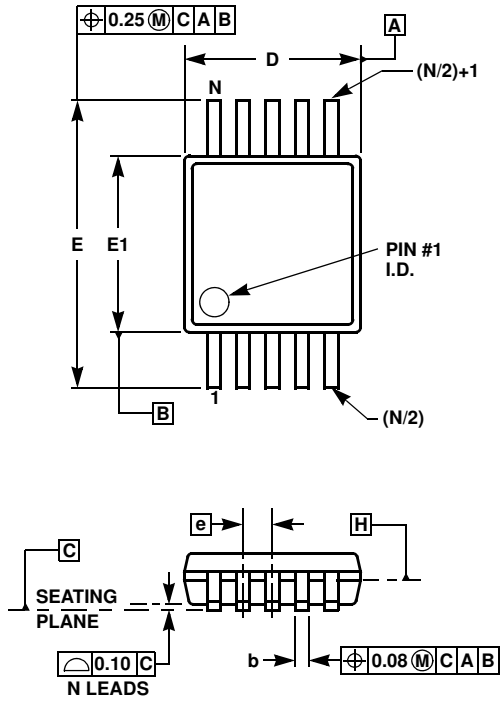

MDP0043
MINI SO PACKAGE FAMILY

SYMBOL	MILLIMETERS		TOLERANCE	NOTES
	MSOP8	MSOP10		
A	1.10	1.10	Max.	-
A1	0.10	0.10	±0.05	-
A2	0.86	0.86	±0.09	-
b	0.33	0.23	+0.07/-0.08	-
c	0.18	0.18	±0.05	-
D	3.00	3.00	±0.10	1, 3
E	4.90	4.90	±0.15	-
E1	3.00	3.00	±0.10	2, 3
e	0.65	0.50	Basic	-
L	0.55	0.55	±0.15	-
L1	0.95	0.95	Basic	-
N	8	10	Reference	-

Rev. D 2/07

NOTES:

1. Plastic or metal protrusions of 0.15mm maximum per side are not included.
2. Plastic interlead protrusions of 0.25mm maximum per side are not included.
3. Dimensions "D" and "E1" are measured at Datum Plane "H".
4. Dimensioning and tolerancing per ASME Y14.5M-1994.

All Intersil U.S. products are manufactured, assembled and tested utilizing ISO9000 quality systems. Intersil Corporation's quality certifications can be viewed at www.intersil.com/design/quality

Intersil products are sold by description only. Intersil Corporation reserves the right to make changes in circuit design, software and/or specifications at any time without notice. Accordingly, the reader is cautioned to verify that data sheets are current before placing orders. Information furnished by Intersil is believed to be accurate and reliable. However, no responsibility is assumed by Intersil or its subsidiaries for its use; nor for any infringements of patents or other rights of third parties which may result from its use. No license is granted by implication or otherwise under any patent or patent rights of Intersil or its subsidiaries.

For information regarding Intersil Corporation and its products, see www.intersil.com