

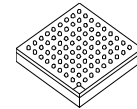

IMX51



Package Information

Plastic Package

Case 2058 13 x 13 mm, 0.5 mm pitch

Case 2017 19 x 19 mm, 0.8 mm pitch

i.MX51 Applications Processors for Consumer and Industrial Products

Ordering Information

See [Table 1](#) on [page 3](#) for ordering information.

1 Introduction

The i.MX51 multimedia applications processors represent Freescale Semiconductor's latest addition to a growing family of multimedia-focused products that offer high performance processing and are optimized for lowest power consumption.

The i.MX51 processors feature Freescale's advanced and power-efficient implementation of the ARM Cortex™-A8 core, which operates at speeds as high as 800 MHz. Up to 200 MHz DDR2 and mobile DDR DRAM clock rates are supported. These devices are suitable for applications such as the following:

- Netbooks (web tablets)
- Nettops (Internet desktop devices)
- Mobile Internet devices (MID)
- Portable media players (PMP)
- Portable navigation devices (PND)
- High-end PDAs
- Gaming consoles
- Automotive navigation and entertainment (see automotive data sheet, IMX51AEC)

| | |
|---|-----|
| 1. Introduction | 1 |
| 1.1. Ordering Information | 3 |
| 1.2. Block Diagram | 4 |
| 2. Features | 5 |
| 2.1. Special Signal Considerations | 12 |
| 3. IOMUX Configuration for Boot Media | 14 |
| 3.1. NAND | 15 |
| 3.2. SD/MMC IOMUX Pin Configuration | 15 |
| 3.3. I ² C IOMUX Pin Configuration | 15 |
| 3.4. eCSPI/CSPI IOMUX Pin Configuration | 16 |
| 3.5. Wireless External Interface Module (WEIM) | 16 |
| 3.6. UART IOMUX Pin Configuration | 16 |
| 3.7. USB-OTG IOMUX Pin Configuration | 16 |
| 4. Electrical Characteristics | 17 |
| 4.1. Chip-Level Conditions | 17 |
| 4.2. Supply Power-Up/Power-Down Requirements and Restrictions | 23 |
| 4.3. I/O DC Parameters | 24 |
| 4.4. Output Buffer Impedance Characteristics | 31 |
| 4.5. I/O AC Parameters | 35 |
| 4.6. Module Timing | 47 |
| 4.7. External Peripheral Interfaces | 74 |
| 5. Package Information and Contact Assignments | 153 |
| 5.1. 13 x 13 mm Package Information | 153 |
| 5.2. 19 x 19 mm Package Information | 173 |
| 5.3. 13 x 13 mm, 0.5 Pitch Ball Map | 191 |
| 5.4. 19 x 19 mm, 0.8 Pitch Ball Map | 195 |
| 6. Revision History | 199 |



Features include the following:

- **Smart Speed Technology**—The heart of the i.MX51 processors is a level of power management throughout the device that enables the rich suite of multimedia features and peripherals to achieve minimum system power consumption in both active and various low-power modes. Smart Speed Technology enables the designer to deliver a feature-rich product that requires levels of power that are far less than typical industry expectations.
- **Applications Processor**—The i.MX51 processors boost the capabilities of high-tier portable applications by providing for the ever-increasing MIPS needs of operating systems and games. Freescale's Dynamic Voltage and Frequency Scaling (DVFS) allows the device run at much lower voltage and frequency with sufficient MIPS for tasks such as audio decode resulting in significant power reduction.
- **Multimedia Powerhouse**—The multimedia performance of the i.MX51 processors is boosted by a multi-level cache system and further enhanced by a Multi-Standard Hardware Video Codec, autonomous Image Processing Unit, SD and HD720p Triple Video (TV) Encoder with triple video DAC, Neon (including Advanced SIMD, 32-bit Single-Precision floating point support and Vector Floating Point co-processor), and a programmable smart DMA (SDMA) controller.
- **Powerful Graphics Acceleration**—Graphics is the key to mobile game navigation, web browsing, and other applications. The i.MX51 processors provide two independent, integrated Graphics Processing Units: OpenGL ES 2.0 3D graphics accelerator (27 Mtri/s, 166 Mpix/s) and OpenVG 1.1 2D graphics accelerator (166 Mpix/s).
- **Interface Flexibility**—The i.MX51 processor interface supports connection to all popular types of external memories: DDR2, Mobile DDR, NOR Flash, PSRAM, Cellular RAM, NAND Flash (MLC and SLC), and OneNAND. Designers seeking to provide products that deliver a rich multimedia experience find a full suite of on-chip peripherals: LCD controller and CMOS sensor interface, High-Speed USB On-The-Go with PHY, and three High-Speed USB hosts, multiple expansion card ports (High-Speed MMC/SDIO Host and others), 10/100 Ethernet controller, and a variety of other popular interfaces (PATA, UART, I²C, I²S serial audio, and SIM card, among others).
- **Increased Security**—Because the need for advanced security for mobile devices continues to increase, the i.MX51 processors deliver hardware-enabled security features that enable secure e-commerce, digital rights management (DRM), information encryption, secure boot, and secure software downloads. For detailed information about the MX51 security features contact your Freescale representative.

1.1 Ordering Information

Table 1 provides the ordering information.

Table 1. Ordering Information¹

| Part Number ² | Mask Set | Features | Case Temperature Range (°C) | Package ³ |
|--------------------------|----------|---|-----------------------------|---|
| MCIMX512CJM6C | M77X | No hardware video codecs No hardware graphics accelerators | –40 to 95 | 19 x 19 mm, 0.8 mm pitch BGA Case 2017 |
| MCIMX512DJM8C | M77X | No hardware video codecs No hardware graphics accelerators | –20 to 85 | 19 x 19 mm, 0.8 mm pitch BGA Case 2017 |
| MCIMX513CJM6C | M77X | No hardware graphics accelerators | –40 to 95 | 19 x 19 mm, 0.8 mm pitch BGA Case 2017 |
| MCIMX513DJM8C | M77X | No hardware graphics accelerators | –20 to 85 | 19 x 19 mm, 0.8 mm pitch BGA Case 2017 |
| MCIMX515CJM6C | M77X | Full specification | –40 to 95 | 19 x 19 mm, 0.8 mm pitch BGA Case 2017 |
| MCIMX515DJM8C | M77X | Full specification | –20 to 85 | 19 x 19 mm, 0.8 mm pitch BGA Case 2017 |
| MCIMX515DVK8C! | M77X | Full specification | –20 to 85 | 13 x 13 mm, 0.5 mm pitch BGA Case 2058 |

¹ For Junction Temperature (T_j) maximum ratings, see Table 11, "Absolute Maximum Ratings," on page 18.

² Because of an order from the United States International Trade Commission, BGA-packaged product lines and part numbers indicated here currently are not available from Freescale for import or sale in the United States prior to September 2010: Indicated by the Icon (!)

³ Case 2017 and Case 2058 are RoHS compliant, lead-free, MSL = 3.

1.2 Block Diagram

Figure 1 shows the functional modules of the processor.

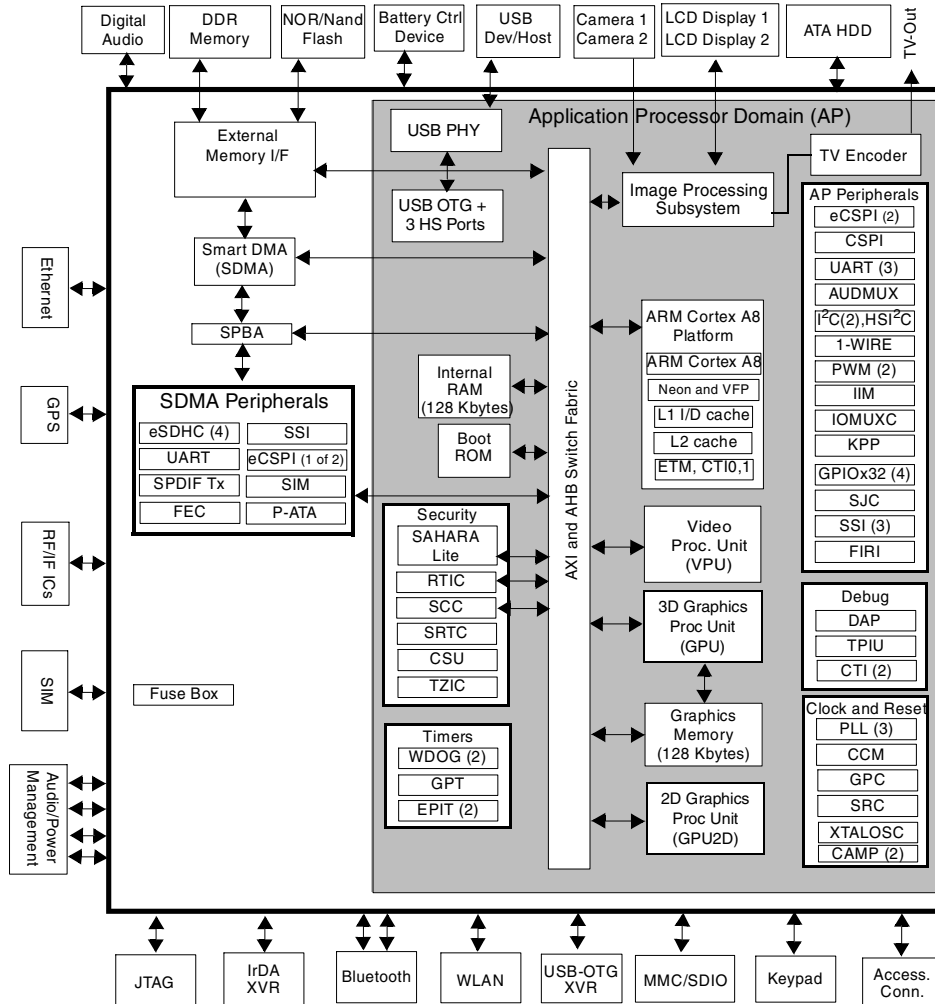

Figure 1. Functional Block Diagram

2 Features

The i.MX51 processor contains a large number of digital and analog modules that are described in [Table 2](#).

Table 2. i.MX51 Digital and Analog Modules

| Block Mnemonic | Block Name | Subsystem | Brief Description |
|-------------------------------|--|-----------------------------------|--|
| 1-WIRE | 1-Wire Interface | Connectivity Peripherals | 1-Wire support provided for interfacing with an on-board EEPROM, and smart battery interfaces, for example: Dallas DS2502. |
| ARM Cortex™-A8 | ARM Cortex™-A8 Platform | ARM | The ARM Cortex™-A8 Core Platform consists of the ARM Cortex™-A8 processor version r2p5 (with TrustZone) and its essential sub-blocks. It contains the Level 2 Cache Controller, 32 Kbyte L1 instruction cache, 32 Kbyte L1 data cache, and a 256 Kbyte L2 cache. The platform also contains an Event Monitor and Debug modules. It also has a NEON co-processor with SIMD media processing architecture, register file with 32 × 64-bit general-purpose registers, an Integer execute pipeline (ALU, Shift, MAC), dual, single-precision floating point execute pipeline (FADD, FMUL), load/store and permute pipeline and a Non-Pipelined Vector Floating Point (VFP) co-processor (VFVP3). |
| Audio Subsystem | Audio Subsystem | Multimedia Peripherals | The elements of the audio subsystem are three Synchronous Serial Interfaces (SSI1-3), a Digital Audio Mux (AUDMUX), and Digital Audio Out (SPDIF TX). See the specific interface listings in this table. |
| AUDMUX | Digital Audio Mux | Multimedia Peripherals | The AUDMUX is a programmable interconnect for voice, audio, and synchronous data routing between host serial interfaces (for example, SSI1, SSI2, and SSI3) and peripheral serial interfaces (audio and voice codecs). The AUDMUX has seven ports (three internal and four external) with identical functionality and programming models. A desired connectivity is achieved by configuring two or more AUDMUX ports. |
| CCM GPC SRC | Clock Control Module Global Power Controller System Reset Controller | Clocks, Resets, and Power Control | These modules are responsible for clock and reset distribution in the system, and also for system power management. The modules include three PLLs and a Frequency Pre-Multiplier (FPM). |
| CSPI-1, eCSPI-2 eCSPI-3 | Configurable SPI, Enhanced CSPI | Connectivity Peripherals | Full-duplex enhanced Synchronous Serial Interface, with data rate up to 66.5 Mbit/s (for eCSPI, master mode). It is configurable to support Master/Slave modes, four chip selects to support multiple peripherals. |
| CSU | Central Security Unit | Security | The Central Security Unit (CSU) is responsible for setting comprehensive security policy within the i.MX51 platform, and for sharing security information between the various security modules. The Security Control Registers (SCR) of the CSU are set during boot time by the High Assurance Boot (HAB) code and are locked to prevent further writing. |
| Debug System | Debug System | System Control | The Debug System provides real-time trace debug capability of both instructions and data. It supports a trace protocol that is an integral part of the ARM Real Time Debug solution (RealView). Real-time tracing is controlled by specifying a set of triggering and filtering resources, which include address and data comparators, cross-system triggers, counters, and sequencers. |

Table 2. i.MX51 Digital and Analog Modules (continued)

| Block Mnemonic | Block Name | Subsystem | Brief Description |
|-------------------------------|---|--------------------------|--|
| EMI | External Memory Interface | Connectivity Peripherals | <p>The EMI is an external and internal memory interface. It performs arbitration between multi-AXI masters to multi-memory controllers, divided into four major channels: fast memories (Mobile DDR, DDR2) channel, slow memories (NOR-FLASH/PSRAM/NAND-FLASH and so on) channel, internal memory (RAM, ROM) channel and graphical memory (GMEM) Channel.</p> <p>In order to increase the bandwidth performance, the EMI separates the buffering and the arbitration between different channels so parallel accesses can occur. By separating the channels, slow accesses do not interfere with fast accesses.</p> <p>EMI features:</p> <ul style="list-style-type: none"> • 64-bit and 32-bit AXI ports • Enhanced arbitration scheme for fast channel, including dynamic master priority, and taking into account which pages are open or closed and what type (Read or Write) was the last access • Flexible bank interleaving • Supports 16/32-bit Mobile DDR up to 200 MHz SDCLK (mDDR400) • Supports 16/32-bit (Non-Mobile) DDR2 up to 200 MHz SDCLK (DDR2-400) • Supports up to 2 Gbit Mobile DDR memories • Supports 16-bit (in muxed mode only) PSRAM memories (sync and async operating modes), at slow frequency, for debugging purposes • Supports 32-bit NOR-Flash memories (only in muxed mode), at slow frequencies for debugging purposes • Supports 4/8-ECC, page sizes of 512 Bytes, 2 Kbytes and 4 Kbytes • NAND-Flash (including MLC) • Multiple chip selects • Enhanced Mobile DDR memory controller, supporting access latency hiding • Supports watermarking for security (Internal and external memories) • Supports Samsung OneNAND™ (only in muxed I/O mode) |
| EPIT-1 EPIT-2 | Enhanced Periodic Interrupt Timer | Timer Peripherals | <p>Each EPIT is a 32-bit “set and forget” timer that starts counting after the EPIT is enabled by software. It is capable of providing precise interrupts at regular intervals with minimal processor intervention. It has a 12-bit prescaler for division of input clock frequency to get the required time setting for the interrupts to occur, and counter values can be programmed on the fly.</p> |
| eSDHC-1 eSDHC-2 eSDHC-3 | Enhanced Multi-Media Card/ Secure Digital Host Controller | Connectivity Peripherals | <p>The features of the eSDHC module, when serving as host, include the following:</p> <ul style="list-style-type: none"> • Conforms to SD Host Controller Standard Specification version 2.0 • Compatible with the MMC System Specification version 4.2 • Compatible with the SD Memory Card Specification version 2.0 • Compatible with the SDIO Card Specification version 1.2 • Designed to work with SD Memory, miniSD Memory, SDIO, miniSDIO, SD Combo, MMC and MMC RS cards • Configurable to work in one of the following modes: <ul style="list-style-type: none"> —SD/SDIO 1-bit, 4-bit —MMC 1-bit, 4-bit, 8-bit • Full-/high-speed mode • Host clock frequency variable between 32 kHz to 52 MHz • Up to 200 Mbps data transfer for SD/SDIO cards using four parallel data lines • Up to 416 Mbps data transfer for MMC cards using eight parallel data lines |

Table 2. i.MX51 Digital and Analog Modules (continued)

| Block Mnemonic | Block Name | Subsystem | Brief Description |
|---|---|----------------------------|--|
| eSDHC-4 (muxed with P-ATA) | Enhanced Multi-Media Card/ Secure Digital Host Controller | Connectivity Peripherals | Can be configured as eSDHC (see above) and is muxed with the P-ATA interface. |
| FEC | Fast Ethernet Controller | Connectivity Peripherals | The Ethernet Media Access Controller (MAC) is designed to support both 10 Mbps and 100 Mbps ethernet/IEEE Std 802.3™ networks. An external transceiver interface and transceiver function are required to complete the interface to the media. |
| FIRI | Fast Infra-Red Interface | Connectivity Peripherals | Fast Infra-Red Interface |
| GPIO-1 GPIO-2 GPIO-3 GPIO-4 | General Purpose I/O Modules | System Control Peripherals | These modules are used for general purpose input/output to external ICs. Each GPIO module supports up to 32 bits of I/O. |
| GPT | General Purpose Timer | Timer Peripherals | Each GPT is a 32-bit “free-running” or “set and forget” mode timer with a programmable prescaler and compare and capture register. A timer counter value can be captured using an external event, and can be configured to trigger a capture event on either the leading or trailing edges of an input pulse. When the timer is configured to operate in “set and forget” mode, it is capable of providing precise interrupts at regular intervals with minimal processor intervention. The counter has output compare logic to provide the status and interrupt at comparison. This timer can be configured to run either on an external clock or on an internal clock. |
| GPU | Graphics Processing Unit | Multimedia Peripherals | The GPU provides hardware acceleration for 2D and 3D graphics algorithms with sufficient processor power to run desk-top quality interactive graphics applications on displays up to HD720 resolution. It supports color representation up to 32 bits per pixel. The GPU with its 128 KByte memory enables high performance mobile 3D and 2D vector graphics at rates up to 27 Mtriangles/sec, 166 Mpixels/sec, 664 Mpixels/sec (Z). |
| GPU2D | Graphics Processing Unit-2D Ver. 1 | Multimedia Peripherals | The GPU2D provides hardware acceleration for 2D graphic algorithms with sufficient processor power to run desk-top quality interactive graphics applications on displays up to HD720 resolution. |
| I ² C-1 I ² C-2 HS-I ² C | I ² C Interface | Connectivity Peripherals | I ² C provides serial interface for controlling peripheral devices. Data rates of up to 400 Kbps are supported by two of the I ² C ports. Data rates of up to 3.4 Mbps (I ² C Specification v2.1) are supported by the HS-I ² C. Note: See the errata for the HS-I ² C in the i.MX51 Chip Errata. The two standard I ² C modules have no errata. |

Table 2. i.MX51 Digital and Analog Modules (continued)

| Block Mnemonic | Block Name | Subsystem | Brief Description |
|----------------------------|--------------------------|----------------------------|---|
| IIM | IC Identification Module | Security | The IC Identification Module (IIM) provides an interface for reading, programming, and/or overriding identification and control information stored in on-chip fuse elements. The module supports electrically programmable poly fuses (e-Fuses). The IIM also provides a set of volatile software-accessible signals that can be used for software control of hardware elements not requiring non-volatility. The IIM provides the primary user-visible mechanism for interfacing with on-chip fuse elements. Among the uses for the fuses are unique chip identifiers, mask revision numbers, cryptographic keys, JTAG secure mode, boot characteristics, and various control signals requiring permanent non-volatility. The IIM also provides up to 28 volatile control signals. The IIM consists of a master controller, a software fuse value shadow cache, and a set of registers to hold the values of signals visible outside the module. |
| IOMUXC | IOMUX Control | System Control Peripherals | This module enables flexible I/O multiplexing. Each I/O pad has default as well as several alternate functions. The alternate functions are software configurable. |
| IPU | Image Processing Unit | Multimedia Peripherals | IPU enables connectivity to displays and image sensors, relevant processing and synchronization. It supports two display ports and two camera ports, through the following interfaces. <ul style="list-style-type: none"> • Legacy Interfaces • Analog TV interfaces (through a TV encoder bridge) <p>The processing includes:</p> <ul style="list-style-type: none"> • Support for camera control • Image enhancement: color adjustment and gamut mapping, gamma correction and contrast enhancement, sharpening and noise reduction • Video/graphics combining • Support for display backlight reduction • Image conversion—resizing, rotation, inversion and color space conversion • Synchronization and control capabilities, allowing autonomous operation. • Hardware de-interlacing support |
| KPP | Keypad Port | Connectivity Peripherals | The KPP supports an 8 × 8 external keypad matrix. The KPP features are as follows: <ul style="list-style-type: none"> • Open drain design • Glitch suppression circuit design • Multiple keys detection • Standby key press detection |
| P-ATA (Muxed with eSDHC-4) | Parallel ATA | Connectivity Peripherals | The P-ATA block is an AT attachment host interface. Its main use is to interface with hard disc drives and optical disc drives. It interfaces with the ATA-5 (UDMA-4) compliant device over a number of ATA signals. It is possible to connect a bus buffer between the host side and the device side. This is muxed with eSDHC-4 interfaces. |
| PWM-1 PWM-2 | Pulse Width Modulation | Connectivity Peripherals | The pulse-width modulator (PWM) has a 16-bit counter and is optimized to generate sound from stored sample audio images. It can also generate tones. The PWM uses 16-bit resolution and a 4 x 16 data FIFO to generate sound. |
| RAM 128 Kbytes | Internal RAM | Internal Memory | Unified RAM, can be split between Secure RAM and Non-Secure RAM |
| ROM 36 Kbytes | Boot ROM | Internal Memory | Supports secure and regular Boot Modes |

Table 2. i.MX51 Digital and Analog Modules (continued)

| Block Mnemonic | Block Name | Subsystem | Brief Description |
|----------------|--------------------------------------|----------------------------|--|
| RTIC | Real Time Integrity Checker | Security | Protecting read-only data from modification is one of the basic elements in trusted platforms. The Run-Time Integrity Checker v3 (RTICv3) module, is a data monitoring device responsible for ensuring that memory content is not corrupted during program execution. The RTICv3 mechanism periodically checks the integrity of code or data sections during normal OS run-time execution without interfering with normal operation. The RTICv3's purpose is to ensure the integrity of the peripheral memory contents, protect against unauthorized external memory elements replacement, and assist with boot authentication. |
| SAHARA Lite | SAHARA security accelerator Lite | Security | SAHARA (Symmetric/Asymmetric Hashing and Random Accelerator) is a security co-processor. It implements symmetric encryption algorithms, (AES, DES, 3DES, and RC4), public key algorithms, hashing algorithms (MD5, SHA-1, SHA-224, and SHA-256), and a hardware random number generator. It has a slave IP bus interface for the host to write configuration and command information, and to read status information. It also has a DMA controller, with an AHB bus interface, to reduce the burden on the host to move the required data to and from memory. |
| SCC | Security Controller | Security | The Security Controller is a security assurance hardware module designed to safely hold sensitive data such as encryption keys, digital right management (DRM) keys, passwords, and biometrics reference data. The SCC monitors the system's alert signal to determine if the data paths to and from it are secure—that is, cannot be accessed from outside of the defined security perimeter. If not, it erases all sensitive data on its internal RAM. The SCC also features a Key Encryption Module (KEM) that allows non-volatile (external memory) storage of any sensitive data that is temporarily not in use. The KEM utilizes a device-specific hidden secret key and a symmetric cryptographic algorithm to transform the sensitive data into encrypted data. |
| SDMA | Smart Direct Memory Access | System Control Peripherals | The SDMA is multi-channel flexible DMA engine. It helps in maximizing system performance by off loading various cores in dynamic data routing. The SDMA features list is as follows: <ul style="list-style-type: none"> • Powered by a 16-bit instruction-set micro-RISC engine • Multi-channel DMA supports up to 32 time-division multiplexed DMA channels • 48 events with total flexibility to trigger any combination of channels • Memory accesses including linear, FIFO, and 2D addressing • Shared peripherals between ARM Cortex™-A8 and SDMA • Very fast context-switching with two-level priority-based preemptive multi-tasking • DMA units with auto-flush and prefetch capability • Flexible address management for DMA transfers (increment, decrement, and no address changes on source and destination address) • DMA ports can handle unit-directional and bi-directional flows (copy mode) • Up to 8-word buffer for configurable burst transfers for EMI • Support of byte-swapping and CRC calculations • A library of scripts and API are available |
| SIM | Subscriber Identity Module Interface | Connectivity Peripherals | The SIM is an asynchronous interface with additional features for allowing communication with Smart Cards conforming to the ISO 7816 specification. The SIM is designed to facilitate communication to SIM cards or pre-paid phone cards. |

Table 2. i.MX51 Digital and Analog Modules (continued)

| Block Mnemonic | Block Name | Subsystem | Brief Description |
|-------------------------|--------------------------------------|----------------------------|--|
| SJC | Secure JTAG Interface | System Control Peripherals | <p>JTAG manipulation is a known hacker's method of executing unauthorized program code, getting control over secure applications, and running code in privileged modes. The JTAG port provides a debug access to several hardware blocks including the ARM processor and the system bus.</p> <p>The JTAG port must be accessible during platform initial laboratory bring-up, manufacturing tests and troubleshooting, as well as for software debugging by authorized entities. However, in order to properly secure the system, unauthorized JTAG usage should be strictly forbidden.</p> <p>In order to prevent JTAG manipulation while allowing access for manufacturing tests and software debugging, the i.MX51 processor incorporates a mechanism for regulating JTAG access. The i.MX51Secure JTAG Controller provides four different JTAG security modes that can be selected via e-fuse configuration.</p> |
| SPBA | Shared Peripheral Bus Arbiter | System Control Peripherals | SPBA (Shared Peripheral Bus Arbiter) is a two-to-one IP bus interface (IP bus) arbiter. |
| SPDIF | Sony Philips Digital Interface | Multimedia Peripherals | A standard digital audio transmission protocol developed jointly by the Sony and Philips corporations. Only the transmitter functionality is supported. |
| SRTC | Secure Real Time Clock | Security | The SRTC incorporates a special System State Retention Register (SSRR) that stores system parameters during system shutdown modes. This register and all SRTC counters are powered by dedicated supply rail NVCC_SRTC_POW. The NVCC_SRTC_POW can be energized even if all other supply rails are shut down. This register is helpful for storing warm boot parameters. The SSRR also stores the system security state. In case of a security violation, the SSRR mark the event (security violation indication). |
| SSI-1 SSI-2 SSI-3 | I2S/SSI/AC97 Interface | Connectivity Peripherals | <p>The SSI is a full-duplex synchronous interface used on the i.MX51 processor to provide connectivity with off-chip audio peripherals. The SSI supports a wide variety of protocols (SSI normal, SSI network, I2S, and AC-97), bit depths (up to 24 bits per word), and clock/frame sync options.</p> <p>Each SSI has two pairs of 8x24 FIFOs and hardware support for an external DMA controller in order to minimize its impact on system performance. The second pair of FIFOs provides hardware interleaving of a second audio stream, which reduces CPU overhead in use cases where two timeslots are being used simultaneously.</p> |
| TVE | TV Encoder | Multimedia | The TVE is implemented in conjunction with the Image Processing Unit (IPU) allowing handheld devices to display captured still images and video directly on a TV or LCD projector. It supports the following analog video outputs: composite, S-video, and component video up to HD720p/1080i. |
| TZIC | TrustZone Aware Interrupt Controller | ARM/Control | The TrustZone Interrupt Controller (TZIC) collects interrupt requests from all i.MX51 sources and routes them to the ARM core. Each interrupt can be configured as a normal or a secure interrupt. Software Force Registers and software Priority Masking are also supported. |

Table 2. i.MX51 Digital and Analog Modules (continued)

| Block Mnemonic | Block Name | Subsystem | Brief Description |
|----------------------------|-------------------------------------|--------------------------|---|
| UART-1 UART-2 UART-3 | UART Interface | Connectivity Peripherals | Each of the UART modules supports the following serial data transmit/receive protocols and configurations: <ul style="list-style-type: none"> • 7 or 8 bit data words, 1 or 2 stop bits, programmable parity (even, odd, or none) • Programmable baud rates up to 4 MHz. This is a higher max baud rate relative to the 1.875 MHz, which is stated by the TIA/EIA-232-F standard and previous Freescale UART modules. • 32-byte FIFO on Tx and 32 half-word FIFO on Rx supporting auto-baud • IrDA 1.0 support (up to SIR speed of 115200 bps) • Option to operate as 8-pins full UART, DCE, or DTE |
| USB | USB 2.0 High-Speed OTG and 3x Hosts | Connectivity Peripherals | USB-OTG contains one high-speed OTG module, which is internally connected to the on-chip HS USB PHY. There are an additional three high-speed host modules that require external USB PHYs. |
| VPU | Video Processing Unit | Multimedia Peripherals | A high-performing video processing unit (VPU), which covers many SD-level video decoders and SD-level encoders as a multi-standard video codec engine as well as several important video processing such as rotation and mirroring. VPU Features: <ul style="list-style-type: none"> • MPEG-4 decode: 720p, 30 fps, simple profile and advanced simple profile • MPEG-4 encode: D1, 25/30 fps, simple profile • H.263 decode: 720p, 30 fps, profile 3 • H.263 encode: D1, 25/30 fps, profile 3 • H.264 decode: 720p, 30 fps, baseline, main, and high profile • H.264 encode: D1, 25/30 fps, baseline profile • MPEG-2 decode: 720p, 30 fps, MP-ML • MPEG-2 encode: D1, 25/30 fps, MP-ML (in software with partial acceleration in hardware) • VC-1 decode: 720p, 30 fps, simple, main, and advanced profile • DivX decode: 720p, 30 fps versions 3, 4, and 5 • RV10 decode: 720p, 30 fps • MJPEG decode: 32 Mpix/s • MJPEG encode: 64 Mpix/s |
| WDOG-1 | Watch Dog | Timer Peripherals | The Watch Dog Timer supports two comparison points during each counting period. Each of the comparison points is configurable to evoke an interrupt to the ARM core, and a second point evokes an external event on the WDOG line. |
| WDOG-2 (TZ) | Watch Dog (TrustZone) | Timer Peripherals | The TrustZone Watchdog (TZ WDOG) timer module protects against TrustZone starvation by providing a method of escaping normal mode and forcing a switch to the TZ mode. TZ starvation is a situation where the normal OS prevents switching to the TZ mode. This situation should be avoided, as it can compromise the system's security. Once the TZ WDOG module is activated, it must be serviced by TZ software on a periodic basis. If servicing does not take place, the timer times out. Upon a time-out, the TZ WDOG asserts a TZ mapped interrupt that forces switching to the TZ mode. If it is still not served, the TZ WDOG asserts a security violation signal to the CSU. The TZ WDOG module cannot be programmed or deactivated by a normal mode SW. |
| XTALOSC | Crystal Oscillator I/F | Clocking | The XTALOSC module allows connectivity to an external crystal. |

2.1 Special Signal Considerations

Table 3 lists special signal considerations for the i.MX51. The signal names are listed in alphabetical order. The package contact assignments are found in Section 5, “Package Information and Contact Assignments.” Signal descriptions are defined in the *i.MX51 Multimedia Applications Processor Reference Manual* (MCIMX51RM).

Table 3. Special Signal Considerations

| Signal Name | Remarks |
|---|--|
| CKIH1, CKIH2 | Inputs feeding CAMPLEs (Clock Amplifiers) that have on-chip ac coupling precluding the need for external coupling capacitors. The CAMPLEs are enabled by default, but the main clocks feeding the on-chip clock tree are sourced from XTAL/EXTAL by default. Optionally, the use of a low jitter external oscillators to feed CKIH1 or CKIH2 (while not required) can be an advantage if low jitter or special frequency clock sources are required by modules driven by CKIH1 or CKIH2. See CCM chapter in the <i>i.MX51 Multimedia Applications Processor Reference Manual</i> (MCIMX51RM) for details on the respective clock trees. After initialization, the CAMPLEs could be disabled (if not used) by CCM registers (CCR CAMPLEx_EN field). If disabled, the on-chip CAMPLE output is low; the input is irrelevant. If unused, the user should tie CKIH1/CKIH2 to GND for best practice. |
| CLK_SS | Clock Source Select is the input that selects the default reference clock source providing input to the DPLLs. To use a reference in the megahertz range per Table 8, tie CLK_SS to GND to select EXTAL/XTAL. To use a reference in the kilohertz range per Table 59, tie CLK_SS to NVCC_PER3 to select CKIL. After initialization, the reference clock source can be changed (initial setting is overwritten). Note: Because this input has a keeper circuit, Freescale recommends tying this input to directly to GND or NVCC_PER3. If a series resistor is used its value must be $\leq 4.7 \text{ k}\Omega$. |
| COMP | The user should bypass this reference with an external 0.1 μF capacitor tied to GND. If TV OUT is not used, float the COMP contact and ensure the DACs are powered down. Note: Previous engineering samples required this reference to be bypassed to a positive supply. |
| FASTR_ANA and FASTR_DIG | These signals are reserved for Freescale manufacturing use only. User must tie both connections to GND. |
| GPANAIO | This signal is reserved for Freescale manufacturing use only. Users should float this output. |
| GPIO_NAND | This is a general-purpose input/output (GPIO3_12) on the NVCC_NANDEF_A power rail. |
| IOB, IOG, IOR, IOB_BACK, IOG_BACK, and IOR_BACK | These signals are analog TV outputs that should be tied to GND when not being used. |
| JTAG_nnnn | The JTAG interface is summarized in Table 4. Use of external resistors is unnecessary. However, if external resistors are used, the user must ensure that the on-chip pull-up/down configuration is followed. For example, do not use an external pull down on an input that has on-chip pull-up. JTAG_TDO is configured with a keeper circuit such that the floating condition is eliminated if an external pull resistor is not present. An external pull resistor on JTAG_TDO is detrimental and should be avoided. JTAG_MOD is referenced as SJC_MOD in the <i>i.MX51 Multimedia Applications Processor Reference Manual</i> (MCIMX51RM). Both names refer to the same signal. JTAG_MOD must be externally connected to GND for normal operation. Termination to GND through an external pull-down resistor (such as 1 $\text{k}\Omega$) is allowed. |
| NC | These signals are No Connect (NC) and should be floated by the user. |

Table 3. Special Signal Considerations (continued)

| Signal Name | Remarks |
|------------------------|---|
| PMIC_INT_REQ | <p>When using the MC13892 power management IC, the PMIC_INT_REQ high-priority interrupt input on i.MX51 should be either floated or tied to NVCC_SRTC_POW with a 4.7 kΩ to 68 kΩ resistor. This avoids a continuous current drain on the real-time clock backup battery due to a 100 kΩ on-chip pull-up resistor.</p> <p>PMIC_INT_REQ is not used by the Freescale BSP (board support package) software. The BSP requires that the general-purpose INT output from the MC13892 be connected to the i.MX51 GPIO input GPIO1_8 configured to cause an interrupt that is not high-priority.</p> <p>The original intent was for PMIC_INT_REQ to be connected to a circuit that detects when the battery is almost depleted. In this case, the I/O must be configured as alternate mode 0 (ALTO = power fail).</p> |
| POR_B | <p>This cold reset negative logic input resets all modules and logic in the IC.</p> <p>Note: The POR_B input must be immediately asserted at power-up and remain asserted until after the last power rail is at its working voltage.</p> |
| RESET_IN_B | <p>This warm reset negative logic input resets all modules and logic except for the following:</p> <ul style="list-style-type: none"> • Test logic (JTAG, IOMUXC, DAP) • SRTC • Memory repair – Configuration of memory repair per fuse settings • Cold reset logic of WDOG – Some WDOG logic is only reset by POR_B. See WDOG chapter in <i>i.MX51 Multimedia Applications Processor Reference Manual</i> (MCIMX51RM) for details. |
| RREFEXT | <p>Determines the reference current for the USB PHY bandgap reference. An external 6.04 kΩ 1% resistor to GND is required.</p> |
| SGND, SVCC, and SVDDGP | <p>These sense lines provide the ability to sense actual on-chip voltage levels on their respective supplies. SGND monitors differentials of the on-chip ground versus an external power source. SVCC monitors on-chip VCC, and SVDDGP monitors VDDGP. Freescale recommends connection of the SVCC and SVDDGP signals to the feedback inputs of switching power-supplies or to test points.</p> |
| STR | <p>This signal is reserved for Freescale manufacturing use. The user should float this signal.</p> |
| TEST_MODE | <p>TEST_MODE is for Freescale factory use only. This signal is internally connected to an on-chip pull-down device. Users must either float this signal or tie it to GND.</p> |
| VREF | <p>When using VREF with DDR-2 I/O, the nominal 0.9 V reference voltage must be half of the NVCC_EMI_DRAM supply. The user must tie VREF to a precision external resistor divider. Use a 1 kΩ 0.5% resistor to GND and a 1 kΩ 0.5% resistor to NVCC_EMI_DRAM. Shunt each resistor with a closely-mounted 0.1 μF capacitor.</p> <p>To reduce supply current, a pair of 1.5 kΩ 0.1% resistors can be used. Using resistors with recommended tolerances ensures the \pm 2% VREF tolerance (per the DDR-2 specification) is maintained when four DDR-2 ICs plus the i.MX51 are drawing current on the resistor divider.</p> <p>Note: When VREF is used with mDDR this signal must be tied to GND.</p> |
| VREFOUT | <p>This signal determines the Triple Video DAC (TVDAC) reference voltage. The user must tie VREFOUT to an external 1.05 kΩ 1% resistor to GND.</p> |

Table 3. Special Signal Considerations (continued)

| Signal Name | Remarks |
|-------------|---|
| VREG | This regulator is no longer used and should be floated by the user. |
| XTAL/EXTAL | <p>The user should tie a fundamental-mode crystal across XTAL and EXTAL. The crystal must be rated for a maximum drive level of 100 μW or higher. An ESR (equivalent series resistance) of 80 Ω or less is recommended. Freescale BSP (Board Support Package) software requires 24 MHz on EXTAL.</p> <p>The crystal can be eliminated if an external 24 MHz oscillator is available. In this case, EXTAL must be directly driven by the external oscillator and XTAL is floated. The EXTAL signal level must swing from NVCC_OSC to GND. If the clock is used for USB, then there are strict jitter requirements: < 50 ps peak-to-peak below 1.2 MHz and < 100 ps peak-to-peak above 1.2 MHz for the USB PHY. The COSC_EN bit in the CCM (Clock Control Module) must be cleared to put the on-chip oscillator circuit in bypass mode which allows EXTAL to be externally driven. COSC_EN is bit 12 in the CCR register of the CCM.</p> |

Table 4. JTAG Controller Interface Summary

| JTAG | I/O Type | On-Chip Termination |
|------------|-------------------------|--------------------------|
| JTAG_TCK | Input | 100 k Ω pull-down |
| JTAG_TMS | Input | 47 k Ω pull-up |
| JTAG_TDI | Input | 47 k Ω pull-up |
| JTAG_TDO | 3-state output | Keeper |
| JTAG_TRSTB | Input | 47 k Ω pull-up |
| JTAG_DE_B | Input/open-drain output | 47 k Ω pull-up |
| JTAG_MOD | Input | 100 k Ω pull-up |

3 IOMUX Configuration for Boot Media

The information provided in this section describes the contacts assigned for each type of bootable media. It also includes data about the clocks used during boot flow and their frequencies. Signals that can be multiplexed appear in tables throughout this section. See the IOMUXC chapter in the *i.MX51 Multimedia Applications Processor Reference Manual (MCIMX51RM)* for details about how to program the IOMUX controller.

3.1 NAND

The NAND Flash Controller (NFC) signals are not configured in the IOMUX. The NFC interface uses dedicated contacts on the IC.

3.2 SD/MMC IOMUX Pin Configuration

Table 5 shows the SD/MMC IOMUX pin configuration.

Table 5. SD/MMC IOMUX Pin Configuration

| Signal | eSDHC1 | eSDHC2 | eSDHC3 | eSDHC4 |
|---------|------------------|----------------|--------------------|----------------|
| CLK | SD1_CLK.alt0 | SD2_CLK.alt0 | NANDF_RDY_INT.alt5 | NANDF_CS2.alt5 |
| CMD | SD1_CMD.alt0 | SD2_CMD.alt0 | NANDF_CS7.alt5 | NANDF_RB1.alt5 |
| DAT0 | SD1_DATA0.alt0 | SD2_DATA0.alt0 | NANDF_WE_B.alt2 | NANDF_CS3.alt5 |
| DAT1 | N/A ¹ | N/A | N/A | N/A |
| DAT2 | N/A | N/A | N/A | N/A |
| CD/DAT3 | SD1_DATA3.alt0 | SD2_DATA3.alt0 | NANDF_RB0.alt5 | NANDF_CS6.alt5 |
| DAT4 | N/A | N/A | N/A | N/A |
| DAT5 | N/A | N/A | N/A | N/A |
| DAT6 | N/A | N/A | N/A | N/A |
| DAT7 | N/A | N/A | N/A | N/A |

¹ N/A in the ROM code indicates the pins are not available.

Only DAT0 is available when the SD/MMC is used for boot. The remaining lines (DAT1–DAT7) are not available.

3.3 I²C IOMUX Pin Configuration

The contacts assigned to the signals used by the three I²C modules is shown in Table 6.

Table 6. I²C IOMUX Pin Configuration

| Signal | HSI ² C | I ² C1 | I ² C2 |
|--------|--------------------|-------------------|-------------------|
| SDA | I2C1_DAT.alt0 | I2C1_DAT.alt0 | GPIO1_3.alt2 |
| SCL | I2C1_CLK.alt0 | I2C1_CLK.alt0 | GPIO1_2.alt2 |

3.4 eCSPI/CSPI IOMUX Pin Configuration

The contacts assigned to the signals used by the three SPI modules is shown in [Table 7](#).

Table 7. SPI IOMUX Pin Configuration

| Signal | eCSPI1 | eCSPI2 | CSPI |
|--------|------------------|----------------|------------------|
| MISO | CSPI1_MISO.alt0 | NANDF_RB3.alt2 | USBH1_NXT.alt1 |
| MOSI | CSPI1_MOSI.alt0 | NANDF_D15.alt2 | USBH1_DIR.alt1 |
| RDY | CSPI1_RDY.alt0 | NANDF_RB1.alt2 | USBH1_STP.alt1 |
| SCLK | CSPI1_SCLK.alt0 | NANDF_RB2.alt2 | USBH1_CLK.alt1 |
| SS0 | N/A ¹ | N/A | N/A |
| SS1 | N/A | N/A | USBH1_DATA5.alt1 |
| SS2 | N/A | N/A | N/A |
| SS3 | N/A | N/A | N/A |

¹ N/A in the ROM code indicates the pins are not available.

3.5 Wireless External Interface Module (WEIM)

The WEIM interface signals are not configured in the IOMUX. The WEIM interface uses dedicated contacts on the IC.

3.6 UART IOMUX Pin Configuration

The contacts assigned to the signals used by the three UART modules are shown in [Table 8](#).

Table 8. UART IOMUX Pin Configuration

| Signal | UART1 | UART2 | UART3 |
|--------|----------------|------------------|----------------|
| TXD | UART1_TXD.alt0 | UART2_TXD.alt0 | UART3_TXD.alt1 |
| RXD | UART1_RXD.alt0 | UART2_RXD.alt0 | UART3_RXD.alt1 |
| CTS | UART1_CTS.alt0 | USBH1_DATA0.alt1 | KEY_COL5.alt2 |
| RTS | UART1_RTS.alt0 | USBH1_DATA3.alt1 | KEY_COL4.alt2 |

3.7 USB-OTG IOMUX Pin Configuration

The interface signals of the UTMI PHY are not configured in the IOMUX. The UTMI PHY interface uses dedicated contacts on the IC.

Table 9. ULPI PHY IOMUX Pin Configuration

| Signal | ULPI PHY |
|---------|--------------|
| USB_PWR | GPIO1_8.alt1 |
| USB_OC | GPIO1_9.alt1 |

Table 9. ULPI PHY IOMUX Pin Configuration (continued)

| Signal | ULPI PHY |
|-------------|--------------|
| USBOTG_CLK | EIM_CS4.alt2 |
| USBOTG_NXT | EIM_CS3.alt2 |
| USBOTG_STP | EIM_CS2.alt2 |
| USBOTG_DAT0 | EIM_D24.alt2 |
| USBOTG_DAT1 | EIM_D25.alt2 |
| USBOTG_DAT2 | EIM_D26.alt2 |
| USBOTG_DAT3 | EIM_D27.alt2 |
| USBOTG_DAT4 | EIM_D28.alt2 |
| USBOTG_DAT5 | EIM_D29.alt2 |
| USBOTG_DAT6 | EIM_D30.alt2 |
| USBOTG_DAT7 | EIM_D31.alt2 |

NOTE

USB OTG ULPI port is not supported and it is not functional. On-chip PHY is always used for the OTG port.

4 Electrical Characteristics

This section provides the device and module-level electrical characteristics for the i.MX51 processor.

4.1 Chip-Level Conditions

This section provides the device-level electrical characteristics for the IC. See [Table 10](#) for a quick reference to the individual tables and sections.

Table 10. i.MX51 Chip-Level Conditions

| For these characteristics, ... | Topic appears ... |
|--|----------------------------|
| Table 11, "Absolute Maximum Ratings" | on page 18 |
| Table 12, "Thermal Resistance Data" | on page 18 |
| Table 13, "i.MX51 Operating Ranges" | on page 19 |
| Table 14, "Interface Frequency" | on page 21 |

CAUTION

Stresses beyond those listed under [Table 11](#) may cause permanent damage to the device. These are stress ratings only. Functional operation of the device at these or any other conditions beyond those indicated under [Table 13](#) is not implied. Exposure to absolute-maximum-rated conditions for extended periods may affect device reliability.

Table 11. Absolute Maximum Ratings

| Parameter Description | Symbol | Min | Max | Unit |
|---|-----------------------------------|------|-------------------------|------|
| Peripheral Core Supply Voltage | VCC | -0.3 | 1.35 | V |
| ARM Core Supply Voltage | VDDGP | -0.3 | 1.15 | V |
| Supply Voltage (UHVIO, I ² C) | Supplies denoted as I/O Supply | -0.5 | 3.6 | V |
| Supply Voltage (except UHVIO, I ² C) | Supplies denoted as I/O Supply | -0.5 | 3.3 | V |
| USB VBUS | VBUS | — | 5.25 | V |
| Input/Output Voltage Range | V _{in} /V _{out} | -0.5 | OVDD + 0.3 ¹ | V |
| ESD Damage Immunity: | V _{esd} | | | V |
| Human Body Model (HBM) | | — | 2000 | |
| Charge Device Model (CDM) | | — | 500 | |
| Storage Temperature Range | T _{STORAGE} | -40 | 125 | °C |
| Junction Temperature (MCIMX51xD—Consumer) | T _J | — | 105 | °C |
| Junction Temperature (MCIMX51xC—Industrial) | T _J | — | 105 | °C |

¹ The term OVDD in this section refers to the associated supply rail of an input or output. The association is described in [Table 128](#) and [Table 131](#). The maximum range can be superseded by the DC tables.

[Table 12](#) provides the thermal resistance data.

Table 12. Thermal Resistance Data

| Rating | Board | Symbol | Value | Unit |
|--|-------|------------------|-------|------|
| Junction to Case ¹ , 19 x 19 mm package | — | R _{θJC} | 6 | °C/W |
| Junction to Case ¹ , 13 x 13 mm package | — | R _{θJC} | 6 | °C/W |

¹ R_{jc-x} per JEDEC 51-12: The junction-to-case thermal resistance. The “x” indicates the case surface where T_{case} is measured and through which 100% of the junction power is forced to flow due to the cold plate heat sink fixture placed either at the top (T) or bottom (B) of the package, with no board attached to the package.

Table 13 shows the i.MX51 operating ranges.

Table 13. i.MX51 Operating Ranges

| Symbol | Parameter | Minimum ¹ | Nominal ² | Maximum ¹ | Unit |
|---|---|----------------------|----------------------|----------------------|------|
| VDDGP MCIMX51xD products (Consumer) | ARM core supply voltage $0 \leq f_{\text{ARM}} \leq 167$ MHz | 0.8 | 0.85 | 1.15 | V |
| | ARM core supply voltage $167 < f_{\text{ARM}} \leq 800$ MHz | 1.05 | 1.1 | 1.15 | V |
| | ARM core supply voltage Stop mode | 0.8 | 0.85 | 1.15 | V |
| VDDGP MCIMX51xC products (Industrial) | ARM core supply voltage $0 < f_{\text{ARM}} \leq 600$ MHz | 0.95 | 1.0 | 1.10 | V |
| | ARM core supply voltage Stop mode | 0.90 | 0.95 | 1.05 | V |
| VCC MCIMX51xD products (Consumer) | Peripheral supply voltage High Performance Mode (HPM) The clock frequencies are derived from AXI and AHB buses using 133 or 166 MHz (as needed). The DDR clock rate is 200 MHz. Note: For detailed information about the use of 133 or 166 MHz clocks, see i.MX51 Multimedia Applications Processor Reference Manual (MCIMX51RM). | 1.175 | 1.225 | 1.275 | V |
| | Peripheral supply voltage Low Performance Mode (LPM) The clock frequencies are derived from AXI and AHB buses at 44 MHz and a DDR clock rate of DDR Clock/3. DDR2 does not support frequencies below 125 MHz per JEDEC. | 1.00 | 1.05 | 1.275 | V |
| | Peripheral supply voltage—Stop mode | 0.9 | 0.95 | 1.275 | V |
| VCC MCIMX51xC products (Industrial) | Peripheral supply voltage High Performance Mode (HPM) The clock frequencies are derived from AXI and AHB buses using 133 or 166 MHz (as needed). The DDR clock rate is 200 MHz. Note: For detailed information about the use of 133 or 166 MHz clocks, see i.MX51 Multimedia Applications Processor Reference Manual (MCIMX51RM). | 1.175 | 1.225 | 1.275 | V |
| | Peripheral supply voltage—Stop mode | 0.90 | 0.95 | 1.275 | V |
| VDDA | Memory arrays voltage—Run Mode | 1.15 | 1.20 | 1.275 | V |
| | Memory arrays voltage—Stop Mode | 0.9 | 0.95 | 1.275 | V |
| VDD_DIG_PLL_A VDD_DIG_PLL_B | PLL Digital supplies | 1.15 | 1.2 | 1.35 | V |
| VDD_ANA_PLL_A VDD_ANA_PLL_B | PLL Analog supplies | 1.75 | 1.8 | 1.95 | V |

Table 13. i.MX51 Operating Ranges (continued)

| Symbol | Parameter | Minimum ¹ | Nominal ² | Maximum ¹ | Unit |
|---|---|----------------------|----------------------|----------------------|------|
| NVCC_EMI NVCC_PER5 NVCC_PER10 NVCC_PER11 NVCC_PER12 NVCC_PER13 NVCC_PER14 | GPIO EMI Supply and additional digital power supplies. | 1.65 | 1.875 or 2.775 | 3.1 | V |
| NVCC_IPUx ³ NVCC_PER3 NVCC_PER8 NVCC_PER9 | GPIO IPU Supply and additional digital power supplies. | 1.65 | 1.875 or 2.775 | 3.1 | V |
| NVCC_EMI_DRAM | DDR and Fuse Read Supply | 1.65 | 1.8 | 1.95 | V |
| VDD_FUSE ⁴ | Fusebox Program Supply (Write Only) | 3.0 | — | 3.3 | V |
| NVCC_NANDF_x ⁵ NVCC_PER15 NVCC_PER17 | Ultra High voltage I/O (UHVIO) supplies | — | | | V |
| | UHVIO_L | 1.65 | 1.875 | 1.95 | |
| | UHVIO_H | 2.5 | 2.775 | 3.1 | |
| | UHVIO_UH | 3.0 | 3.3 | 3.6 | |
| NVCC_USBPHY NVCC_OSC | USB_PHY analog supply, oscillator analog supply ⁶ | 2.25 | 2.5 | 2.75 | V |
| TVDAC_DHVDD, NVCC_TV_BACK, AHVDDRGB | TVE-to-DAC level shifter supply, cable detector supply, analog power supply to RGB channel | 2.69 | 2.75 | 2.91 | V |
| NVCC_HS4_1 NVCC_HS4_2 NVCC_HS6 NVCC_HS10 | HS-GPIO additional digital power supplies | 1.65 | — | 3.1 | V |
| NVCC_I2C | I ² C and HS-I ² C I/O Supply ⁷ | 1.65 | 1.875 | 1.95 | V |
| | | 2.7 | 3.0 | 3.3 | |
| NVCC_SRTC_ POW | SRTC Core and I/O Supply (LVIO) | 1.1 | 1.2 | 1.3 | V |
| VDDA33 | USB PHY I/O analog supply | 3.0 | 3.3 | 3.6 | V |
| VBUS | See Table 11 and Table 126 for details. This is not a power supply. | — | — | — | — |
| T _C | Case Temperature (MCIMX51xD—Consumer) | –20 | — | 85 | °C |
| | Case Temperature (MCIMX51xC—Industrial) | –40 | — | 95 | °C |

¹ Voltage at the package power supply contact must be maintained between the minimum and maximum voltages. The design must allow for supply tolerances and system voltage drops.

² The nominal values for the supplies indicate the target setpoint for a tolerance no tighter than ± 50 mV. Use of supplies with a tighter tolerance allows reduction of the setpoint with commensurate power savings.

³ The NVCC_IPUx rails are isolated from one another. This allows the connection of different supply voltages for each one. For example, NVCC_IPU2 can operate at 1.8 V while NVCC_IPU4 operates at 3.0 V.

- ⁴ In Read mode, Freescale recommends VDD_FUSE be floated or grounded. Tying VDD_FUSE to a positive supply (3.0 V–3.3 V) increases the possibility of inadvertently blowing fuses and is not recommended.
- ⁵ The NAND Flash supplies are composed of three groups: A, B, and C. Each group can be powered with a different supply voltage. For example, NVCC_NANDF_A = 1.8 V, NVCC_NANDF_B = 3.0 V, NVCC_NANDF_C = 2.7 V.
- ⁶ The analog supplies should be isolated in the application design. Use of series inductors is recommended.
- ⁷ Operation of the HS-I²C and I²C is not guaranteed when operated between the supply voltages of 1.95 to 2.7 V.

Table 14. Interface Frequency

| Parameter Description | Symbol | Min | Max | Unit |
|-------------------------------|-------------------|---|-----|------|
| JTAG: TCK Operating Frequency | f _{tck} | See Table 99, "JTAG Timing," on page 132 | | MHz |
| CKIL: Operating Frequency | f _{ckil} | See Table 74, "FPM Specifications," on page 82 | | kHz |
| CKIH: Operating Frequency | f _{ckih} | See Table 47, "CAMP Electrical Parameters (CKIH1, CKIH2)," on page 48 | | MHz |
| XTAL Oscillator | f _{xtal} | 22 | 27 | MHz |

4.1.1 Supply Current

Table 15 shows the fuse supply current.

Table 15. Fuse Supply Current¹

| Description | Symbol | Min | Typ | Max | Unit |
|--|----------------------|-----|-----|-----|------|
| eFuse Program Current. ² Current required to program one eFuse bit: The associated VDD_FUSE supply per Table 13. | I _{program} | — | 60 | 120 | mA |

¹ The read current of approximately 5 mA is derived from the DDR supply (NVCC_EMI_DRAM).

² The current I_{program} is only required during program time.

Table 16 shows the current core consumption (not including I/O) of the i.MX51.

Table 16. i.MX51 Stop Mode Current and Power Consumption

| Mode | Condition | Supply | Nominal | Unit |
|---|--|----------|---------|------|
| Stop Mode <ul style="list-style-type: none"> External reference clocks gated Power gating for ARM and processing units Stop mode voltage | VDDGP = 0.85 V, VCC = 0.95 V, VDDA = 0.95 V ARM CORE in SRPG mode L1 and L2 caches power gated IPU in S&RPG mode VPU and GPU in PG mode All PLLs off, all CCM-generated clocks off CKIL input on with 32 kHz signal present All modules disabled USBPHY PLL off External (MHz) crystal and on-chip oscillator powered down (SBYOS bit asserted) No external resistive loads that cause current flow Standby voltage allowed (VSTBY bit is asserted) T _A = 25 °C | VDDGP | 0.18 | mA |
| | | VCC | 0.35 | |
| | | VDDA | 0.15 | |
| | | NVCC_OSC | 0.012 | |
| | | Total | 0.66 | mW |

Table 16. i.MX51 Stop Mode Current and Power Consumption (continued)

| Mode | Condition | Supply | Nominal | Unit |
|--|--|----------|---------|------|
| Stop Mode <ul style="list-style-type: none"> External reference clocks gated Power gating for ARM and processing units HPM voltage | VDDGP = 1.1 V, VCC = 1.225 V, VDDA = 1.2 V ARM CORE in SRPG mode L1 and L2 caches power gated IPU in S&RPG mode VPU and GPU in PG mode All PLLs off, all CCM-generated clocks off CKIL input on with 32 kHz signal present All modules disabled. USBPHY PLL off External (MHz) crystal and on-chip oscillator powered down (SBYOS bit asserted) No external resistive loads that cause current flow TA = 25°C | VDDGP | 0.24 | mA |
| | | VCC | 0.45 | |
| | | VDDA | 0.2 | |
| | | NVCC_OSC | 0.012 | |
| | | Total | 1.09 | mW |
| Stop Mode <ul style="list-style-type: none"> External reference clocks enabled Power gating for ARM and processing units HPM voltage | VDDGP = 1.1 V, VCC = 1.225 V, VDDA = 1.20 V ARM CORE in SRPG mode L1 and L2 caches power gated IPU in S&RPG mode VPU and GPU in PG mode All PLLs off, all CCM-generated clocks off CKIL input on with 32 kHz signal present All modules disabled USBPHY PLL off External (MHz) crystal and on-chip oscillator powered and generating reference clock No external resistive loads that cause current flow TA = 25 °C | VDDGP | 0.24 | mA |
| | | VCC | 0.45 | |
| | | VDDA | 0.2 | |
| | | NVCC_OSC | 1.5 | |
| | | Total | 4.8 | mW |
| Stop Mode <ul style="list-style-type: none"> External reference clocks enabled No power gating for ARM and processing units HPM voltage | VDDGP = 1.1 V, VCC = 1.225 V, VDDA = 1.2 V All PLLs off, all CCM-generated clocks off CKIL input on with 32 kHz signal present All modules disabled USBPHY PLL off External (MHz) crystal and on-chip oscillator powered and generating reference clock No external resistive loads that cause current flow TA = 25 °C | VDDGP | 50 | mA |
| | | VCC | 2 | |
| | | VDDA | 1.15 | |
| | | NVCC_OSC | 1.5 | |
| | | Total | 63 | mW |

4.1.2 USB PHY Current Consumption

Table 17 shows the USB PHY current consumption.

Table 17. USB PHY Current Consumption

| Parameter | Conditions | | Typical @ 25 °C | Max | Unit |
|--------------------------------------|------------|----|-----------------|-----|------|
| Analog Supply VDDA33 (3.3 V) | Full Speed | RX | 5.5 | 6 | mA |
| | | TX | 7 | 8 | |
| | High Speed | RX | 5 | 6 | |
| | | TX | 5 | 6 | |
| Analog Supply NVCC_USBPHY (2.5 V) | Full Speed | RX | 6.5 | 7 | mA |
| | | TX | 6.5 | 7 | |
| | High Speed | RX | 12 | 13 | |
| | | TX | 21 | 22 | |
| Digital Supply VCC (1.2 V) | Full Speed | RX | 6 | 7 | mA |
| | | TX | 6 | 7 | |
| | High Speed | RX | 6 | 7 | |
| | | TX | 6 | 7 | |
| VDDA33 + NVCC_USBPHY + VCC | Suspend | | 50 | 100 | μA |

4.2 Supply Power-Up/Power-Down Requirements and Restrictions

The system design must comply with the power-up and power-down sequence guidelines as described in this section to guarantee reliable operation of the device. Any deviation from these sequences may result in the following situations:

- Excessive current during power-up phase
- Prevention of the device from booting
- Irreversible damage to the i.MX51 processor (worst-case scenario)

4.2.1 Power-Up Sequence

Figure 2 shows the power-up sequence.

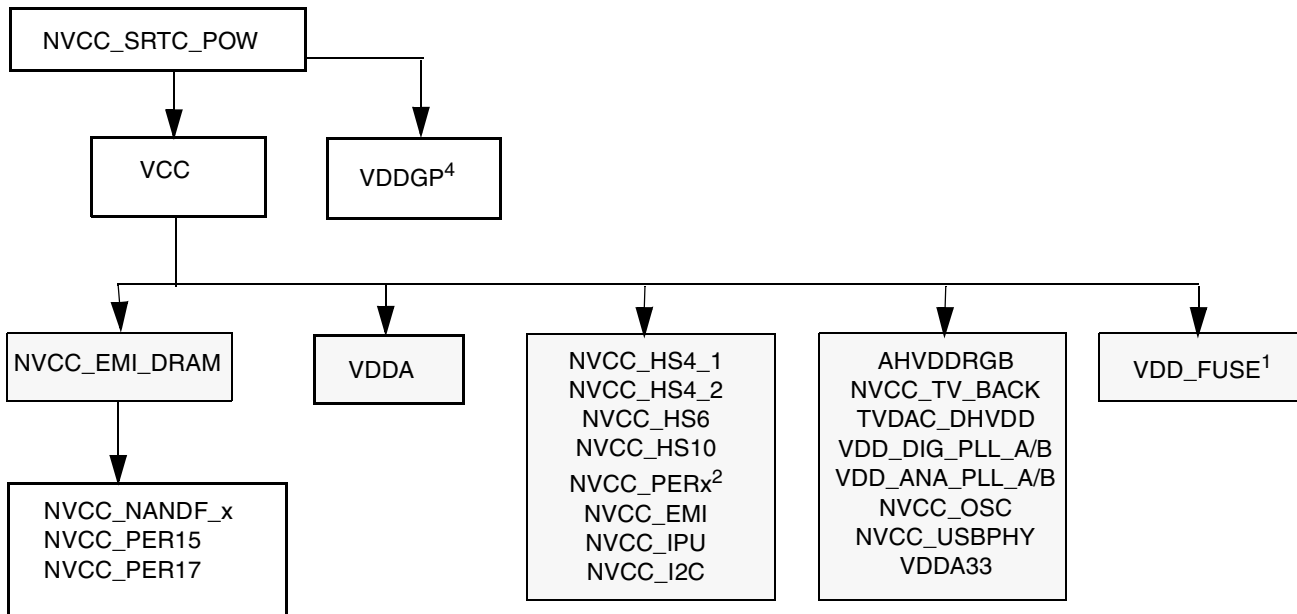

1. VDD_FUSE should only be powered when writing.
2. NVCC_PERx refers to NVCC_PER 3, 5, 8, 9, 10, 11, 12, 13, 14.
3. No power-up sequence dependencies exist between the supplies shown in the block diagram shaded in gray.
4. There is no requirement for VDDGP to be preceded by any other power supply other than NVCC_SRTC_POW.
5. If all of the UHVIO supplies (NVCC_NANDFx, NVCC_PER15 and NVCC_PER17) are less than 2.75 V then there is no requirement on the power up sequence order between NVCC_EMI_DRAM and the UHVIO supplies. However, if the voltage is 2.75 V and above, then NVCC_EMI_DRAM needs to power up before the UHVIO supplies as shown here.

Figure 2. Power-Up Sequence

NOTE

The POR_B input must be immediately asserted at power-up and remain asserted until after the last power rail is at its working voltage.

For more information on power up, see i.MX51 Power-Up Sequence (AN4053).

4.3 I/O DC Parameters

This section includes the DC parameters of the following I/O types:

- General Purpose I/O and High-Speed General Purpose I/O (GPIO/HSGPIO)
- Double Data Rate 2 (DDR2)
- Low Voltage I/O (LVIO)
- Ultra High Voltage I/O (UHVIO)
- High-Speed I²C and I²C
- Enhanced Secure Digital Host Controller (eSDHC)

NOTE

The term OVDD in this section refers to the associated supply rail of an input or output. The association is shown in [Table 128](#) and [Table 131](#).

4.3.1 GPIO/HSGPIO DC Parameters

The parameters in [Table 18](#) are guaranteed per the operating ranges in [Table 13](#), unless otherwise noted.

Table 18. GPIO/HSGPIO DC Electrical Characteristics

| Parameter | Symbol | Test Conditions | Min | Typ | Max | Unit |
|--|-----------------|---|------------------------------|--------------|-----------------------|------|
| High-level output voltage | Voh | I _{out} = -1 mA | OVDD - 0.15 | — | OVDD + 0.3 | V |
| Low-level output voltage | Vol | I _{out} = 1 mA | — | — | 0.15 | V |
| High-level output current | Ioh | V _{out} = 0.8×OVDD Low drive Medium drive High drive Max drive | -1.9 -3.7 -5.2 -6.6 | — | — | mA |
| Low-level output current | Iol | V _{out} = 0.2×OVDD Low drive Medium drive High drive Max drive | 1.9 3.7 5.2 6.6 | — | — | mA |
| High-Level DC input voltage ¹ | VIH | — | 0.7 × OVDD | — | OVDD | V |
| Low-Level DC input voltage ¹ | VIL | — | 0 | — | 0.3×OVDD | V |
| Input Hysteresis | VHYS | OVDD = 1.875 OVDD = 2.775 | 0.25 | 0.34 0.45 | — | V |
| Schmitt trigger VT ₊ ^{1,2} | VT+ | — | 0.5OVDD | — | — | V |
| Schmitt trigger VT ₋ ^{1,2} | VT- | — | — | — | 0.5 × OVDD | V |
| Input current (no pull-up/down) | I _{in} | V _{in} = OVDD or 0 | — | — | See Note ³ | — |
| Input current (22 kΩ Pull-up) | I _{in} | V _{in} = 0 | — | — | 161 | μA |
| Input current (47 kΩ Pull-up) | I _{in} | V _{in} = 0 | — | — | 76 | μA |
| Input current (100 kΩ Pull-up) | I _{in} | V _{in} = 0 | — | — | 36 | μA |
| Input current (100 kΩ Pull-down) | I _{in} | V _{in} = OVDD | — | — | 36 | μA |
| Keeper Circuit Resistance | — | OVDD = 1.875V OVDD = 2.775V | — — | 22 17 | — — | kΩ |

¹ To maintain a valid level, the transition edge of the input must sustain a constant slew rate (monotonic) from the current DC level through to the target DC level, VIL or VIH. Monotonic input transition time is from 0.1 ns to 1 s.

² Hysteresis of 250 mV is guaranteed over all operating conditions when hysteresis is enabled.

³ I/O leakage currents are listed in [Table 25](#).

4.3.2 DDR2 I/O DC Parameters

The parameters in [Table 19](#) are guaranteed per the operating ranges in [Table 13](#), unless otherwise noted.

Table 19. DDR2 I/O DC Electrical Parameters

| Parameters | Symbol | Test Conditions | Min | Max | Unit |
|---|--------|-------------------------------|----------------|-----------------------|------|
| High-level output voltage | Voh | — | OVDD – 0.28 | — | V |
| Low-level output voltage | Vol | — | — | 0.28 | V |
| Output minimum Source Current | Ioh | OVDD = 1.7 V Vout = 1.42 V | –13.4 | — | mA |
| Output min Sink Current | Iol | OVDD = 1.7 V Vout = 0.28 V | 13.4 | — | mA |
| DC input Logic High | VIH | — | OVDD/2 + 0.125 | OVDD + 0.3 | V |
| DC input Logic Low | VIL | — | –0.3 | OVDD/2 – 0.125 | V |
| Input voltage range of each differential input | Vin | — | –0.3 | OVDD + 0.3 | V |
| Differential input voltage required for switching | Vid | — | 0.25 | OVDD + 0.6 | V |
| Termination Voltage | Vtt | Vtt tracking OVDD/2 | OVDD/2 – 0.04 | OVDD/2 + 0.04 | V |
| Input current (no pull-up/down) | Iin | VI = 0 VI = OVDD | — — | See Note ¹ | — |

¹ I/O leakage currents are listed in [Table 25](#).

4.3.3 Low Voltage I/O (LVIO) DC Parameters

The parameters in [Table 20](#) are guaranteed per the operating ranges in [Table 13](#), unless otherwise noted.

Table 20. LVIO DC Electrical Characteristics

| DC Electrical Characteristics | Symbol | Test Conditions | Min | Typ | Max | Unit |
|--|----------|---|------------------------------|--------------|------------|------|
| High-level output voltage | Voh | Iout = –1 mA | OVDD – 0.15 | — | — | V |
| Low-level output voltage | Vol | Iout = 1 mA | — | — | 0.15 | V |
| High-level output current | I Ioh | Vout = 0.8 × OVDD Low Drive Medium Drive High Drive Max Drive | –2.1 –4.2 –6.3 –8.4 | — | — | mA |
| Low-level output current | I Iol | Vout = 0.2 × OVDD Low Drive Medium Drive High Drive Max Drive | 2.1 4.2 6.3 8.4 | — | — | mA |
| High-Level DC input voltage ¹ | VIH | — | 0.7 × OVDD | — | OVDD | V |
| Low-Level DC input voltage ¹ | VIL | — | 0 | — | 0.3 × OVDD | V |
| Input Hysteresis | VHYS | OVDD = 1.875 OVDD = 2.775 | 0.35 | 0.62 1.27 | — | V |

Table 20. LVIO DC Electrical Characteristics (continued)

| DC Electrical Characteristics | Symbol | Test Conditions | Min | Typ | Max | Unit |
|--|--------|--------------------------------------|-------------------|----------|-----------------------|------------|
| Schmitt trigger VT_+ ^{1,2} | VT_+ | — | $0.5 \times OVDD$ | — | — | V |
| Schmitt trigger VT_- ^{1,2} | VT_- | — | — | — | $0.5 \times OVDD$ | V |
| Input current (no pull-up/down) | lin | $VI = 0$ or $OVDD$ | — | — | See Note ³ | — |
| Input current (22 k Ω Pull-up) | lin | $VI = 0$ | — | — | 161 | μA |
| Input current (47 k Ω Pull-up) | lin | $VI = 0$ | — | — | 76 | μA |
| Input current (100 k Ω Pull-up) | lin | $VI = 0$ | — | — | 36 | μA |
| Input current (100 k Ω Pull-down) | lin | $VI = OVDD$ | — | — | 36 | μA |
| Keeper Circuit Resistance | — | $OVDD = 1.875 V$ $OVDD = 2.775 V$ | — — | 22 17 | — — | k Ω |

¹ To maintain a valid level, the transition edge of the input must sustain a constant slew rate (monotonic) from the current DC level through to the target DC level, V_{IL} or V_{IH} . Monotonic input transition time is from 0.1 ns to 1 s.

² Hysteresis of 250 mV is guaranteed over all operating conditions when hysteresis is enabled.

³ I/O leakage currents are listed in Table 25.

4.3.4 Ultra-High Voltage I/O (UHVIO) DC Parameters

The parameters in Table 21 are guaranteed per the operating ranges in Table 13, unless otherwise noted.

Table 21. UHVIO DC Electrical Characteristics

| DC Electrical Characteristics | Symbol | Test Conditions | Min | Typ | Max | Unit |
|--|--------------|--|------------------------|-----|-------------------|------|
| High-level output voltage | V_{oh} | $I_{out} = -1mA$ | $OVDD - 0.15$ | — | — | V |
| Low-level output voltage | V_{ol} | $I_{out} = 1mA$ | — | — | 0.15 | V |
| High-level output current, low voltage mode | I_{oh_lv} | $V_{out} = 0.8 \times OVDD$ Low Drive Medium Drive High Drive | -2.2 -4.4 -6.6 | — | — | mA |
| High-level output current, high voltage mode | I_{oh_hv} | $V_{out} = 0.8 \times OVDD$ Low Drive Medium Drive High Drive | -5.1 -10.2 -15.3 | — | — | mA |
| Low-level output current, low voltage mode | I_{ol_lv} | $V_{out} = 0.2 \times OVDD$ Low Drive Medium Drive High Drive | 2.2 4.4 6.6 | — | — | mA |
| Low-level output current, high voltage mode | I_{ol_hv} | $V_{out} = 0.2 \times OVDD$ Low Drive Medium Drive High Drive | 5.1 10.2 15.3 | — | — | mA |
| High-Level DC input voltage ^{1,2} | V_{IH} | — | $0.7 \times OVDD$ | — | $OVDD$ | V |
| Low-Level DC input voltage ^{2,3} | V_{IL} | — | 0 | — | $0.3 \times OVDD$ | V |

Table 21. UHVIO DC Electrical Characteristics (continued)

| DC Electrical Characteristics | Symbol | Test Conditions | Min | Typ | Max | Unit |
|--|--------|---------------------------------------|--------------|-----|-----------------------|------------|
| Input Hysteresis | VHYS | Low voltage mode High voltage mode | 0.38 0.95 | — | 0.43 1.33 | V |
| Schmitt trigger VT_+ ^{2,3} | VT+ | — | 0.5OVDD | — | — | V |
| Schmitt trigger VT_- ^{2,4} | VT- | — | — | — | $0.5 \times OVDD$ | V |
| Input current (no pull-up/down) | lin | $V_{in} = 0$ $V_{in} = OVDD$ | — | — | See Note ⁴ | — |
| Input current (22 k Ω Pull-up) | lin | $V_{in} = 0$ | — | — | 202 | μA |
| Input current (75 k Ω Pull-up) | lin | $V_{in} = 0$ | — | — | 61 | μA |
| Input current (100 k Ω Pull-up) | lin | $V_{in} = 0$ | — | — | 47 | μA |
| Input current (360 k Ω Pull-down) | lin | $V_{in} = OVDD$ | — | — | 5.7 | μA |
| Keeper Circuit Resistance | — | NA | — | 17 | — | k Ω |

¹ To maintain a valid level, the transitioning edge of the input must sustain a constant slew rate (monotonic) from the current DC level through to the target DC level, VIL or VIH. Monotonic input transition time is from 0.1 ns to 1 s.

² Overshoot and undershoot conditions (transitions above OVDD and below OVSS) on switching pads must be held below 0.6 V, and the duration of the overshoot/undershoot must not exceed 10% of the system clock cycle. Overshoot/undershoot must be controlled through printed circuit board layout, transmission line impedance matching, signal line termination, or other methods. Non-compliance to this specification may affect device reliability or cause permanent damage to the device.

³ Hysteresis of 250 mV is guaranteed over all operating conditions when hysteresis is enabled.

⁴ I/O leakage currents are listed in [Table 25](#).

The UHVIO type of I/O cells have to be configured properly according to their supply voltage level, in order to prevent permanent damage to them and in order to not degrade their timing performance.

The HVE control bit of the I/O cell (in IOMUX control registers) should be set to 1 for Low voltage operation and to 0 for High voltage operation.

The HVE bit should be set as follows:

- HVE = 0: High output voltage mode (3.0V to 3.6V)
- HVE = 1: Low output voltage mode (1.65V to 3.1V)

This is related to power domains, such as NVCC_NANDE, NVCC_PER15, and NVCC_PER17.

If HVE bit is not set properly when high voltage level is applied for long durations, it may cause permanent damage over a period of time, causing reduced timing performance of the pad. Similarly, not setting HVE bit properly for low voltage will degrade pad timing performance.

The below discussion clarifies concerns about boot-up period.

The HVE bit is set, by default, to 1 for low voltage operation. As a result, there might be a short period conflict between the HVE bit value and the applied voltage. This conflict is acceptable under the following conditions:

- The UHVIO pads receive supply voltage up to 3.3V (3.6V max); however, the pads do not toggle during the boot-up sequence (using another interface as a boot code source), for boot-up period of about 22 msec.
- The UHVIO pads receive up to 3.15V (3.3V max) and are used for accessing the boot code, for boot-up period of about 11 msec.

In any case, it is recommended to try to minimize the duration of this period and reduce the amount of toggling on the pads as much as possible. For this, it is recommended to add proper HVE bit programming to the DCD boot-up tables. DCD is a table located in the start of the image that can hold up to 60 address/values. ROM code reads addresses and writes values to it. This space should be sufficient to reprogram the NAND Flash pads for HVE bits.

4.3.5 I²C I/O DC Parameters

NOTE

See the errata for HS-I2C in i.MX51 Chip Errata document. The two standard I²C modules have no errata.

The DC Electrical Characteristics listed in [Table 22](#) are guaranteed using operating ranges per [Table 13](#), unless otherwise noted.

Table 22. I²C Standard/Fast/High-Speed Mode Electrical Parameters for Low/Medium Drive Strength

| Parameter | Symbol | Test Conditions | Min | Typ | Max | Unit |
|--|------------------|----------------------------|------------|-----|-----------------------|------|
| Low-level output voltage | V _{OL} | I _{OL} = 3 mA | — | — | 0.4 | V |
| High-Level DC input voltage ¹ | V _{IH} | — | 0.7 × OVDD | — | OVDD | V |
| Low-Level DC input voltage ¹ | V _{IL} | — | 0 | — | 0.3 × OVDD | V |
| Input Hysteresis | V _{HYS} | — | 0.25 | — | — | V |
| Schmitt trigger V _{T+} ^{1,2} | V _{T+} | — | 0.5 × OVDD | — | — | V |
| Schmitt trigger V _{T-} ^{1,2} | V _{T-} | — | — | — | 0.5 × OVDD | V |
| I/O leakage current (no pull-up) | I _{in} | V _I = OVDD or 0 | — | — | See Note ³ | — |

¹ To maintain a valid level, the transitioning edge of the input must sustain a constant slew rate (monotonic) from the current DC level through to the target DC level, V_{IL} or V_{IH}. Monotonic input transition time is from 0.1 ns to 1 s.

² Hysteresis of 250 mV is guaranteed over all operating conditions when hysteresis is enabled.

³ I/O leakage currents are listed in [Table 25](#).

4.3.6 USBOTG Electrical DC Parameters

This section describes the electrical DC parameters of USBOTG.

4.3.7 USB Port Electrical DC Characteristics

Table 23 and Table 24 list the electrical DC characteristics.

Table 23. USBOTG Interface Electrical Specification

| Parameter | Symbol | Signals | Min | Max | Unit | Test Conditions |
|---------------------|--------|---|------------|-----------|------|---------------------------|
| Input High Voltage | VIH | USB_VPOUT USB_VMOOUT USB_XRXD, USB_VPIN, USB_VMIN | VDD x 0.7 | VDD | V | — |
| Input low Voltage | VIL | USB_VPOUT USB_VMOOUT USB_XRXD, USB_VPIN, USB_VMIN | 0 | VDD x 0.3 | V | — |
| Output High Voltage | VOH | USB_VPOUT USB_VMOOUT USB_TXENB | VDD – 0.43 | — | V | 7 mA Drv at IOH = 5 mA |
| Output Low Voltage | VOL | USB_VPOUT USB_VMOOUT USB_TXENB | — | 0.43 | V | 7 mA Drv at IOH = 5 mA |

Table 24. USB Interface Electrical Specification

| Parameter | Symbol | Signals | Min | Max | Unit | Test Conditions |
|---------------------|--------|---|-----------|-----------|------|----------------------------|
| Input High Voltage | VIH | USB_DAT_VP USB_SE0_VM USB_RCV, USB_VP1, USB_VM1 | VDD x 0.7 | VDD | V | — |
| Input Low Voltage | VIL | USB_DAT_VP USB_SE0_VM USB_RCV, USB_VP1, USB_VM1 | 0 | VDD x 0.3 | V | — |
| Output High Voltage | VOH | USB_DAT_VP USB_SE0_VM USB_TXOE_B | VDD –0.43 | — | V | 7 mA Drv at Iout = 5 mA |
| Output Low Voltage | VOL | USB_DAT_VP USB_SE0_VM USB_TXOE_B | — | 0.43 | V | 7 mA Drv at Iout = 5 mA |

Table 25 shows the I/O leakage currents that are based on the operating ranges in Table 13 and the operating temperatures in Table 1.

Table 25. I/O Leakage Current

| Contact Group | Supply Rail | Test Condition | Min | Typ | Max | Unit |
|--|---------------------------|--|-----|-----|------|------|
| NANDF | NVCC_NANDF | V[I/O] = GND or Positive Supply Rail, I/O = High Z | — | — | ±1 | μA |
| EIM | NVCC_EMI | V[I/O] = GND or Positive Supply Rail, I/O = High Z | — | — | ±1 | μA |
| DRAM | NVCC_DRAM | V[I/O] = GND or Positive Supply Rail, I/O = High Z | — | — | ±2.5 | μA |
| CSI1, CSI2, DISP1_Data[5:0] | NVCC_HSx | V[I/O] = GND or Positive Supply Rail, I/O = High Z | — | — | ±1.5 | μA |
| I ² C1 | NVCC_I2C | V[I/O] = GND or Positive Supply Rail, I/O = High Z | — | — | ±1 | μA |
| DI1_DAT[23:6], DISPB_SER_x, DI_GP_x | NVCC_IPU | V[I/O] = GND or Positive Supply Rail, I/O = High Z | — | — | ±2 | μA |
| CKIL, PMIC_x | NVCC_SRTC_POW | V[I/O] = GND or Positive Supply Rail, I/O = High Z | — | — | ±1 | μA |
| EXTAL, XTAL | NVCC_OSC | V[I/O] = GND or Positive Supply Rail, I/O = High Z | — | — | ±170 | μA |
| ID, GPANAIO | NVCC_USBPHY | V[I/O] = GND or Positive Supply Rail, I/O = High Z | — | — | ±170 | μA |
| DISP2_DAT[0:15] | NVCC_IPU, NVCC_HS | V[I/O] = GND or Positive Supply Rail, I/O = High Z | — | — | ±2 | μA |
| SD1, SD2 | NVCC_PER15, NVCC_PER17 | V[I/O] = GND or Positive Supply Rail, I/O = High Z | — | — | ±10 | μA |
| Peripherals except SD1, SD2 | NVCC_PERx | V[I/O] = GND or Positive Supply Rail, I/O = High Z | — | — | ±2 | μA |

4.4 Output Buffer Impedance Characteristics

This section defines the I/O Impedance parameters of the i.MX51 processor.

4.4.1 LVIO I/O Output Buffer Impedance

Table 26 shows the LVIO I/O output buffer impedance.

Table 26. LVIO I/O Output Buffer Impedance

| Parameter | Symbol | Conditions | Min | Typical | | Max | Unit |
|-------------------------|--------|-----------------------------------|-----|--------------|--------------|-----|------|
| | | | | OVDD 2.775 V | OVDD 1.875 V | | |
| Output Driver Impedance | Rpu | Low Drive Strength, Ztl = 150 Ω | 80 | 104 | 150 | 250 | Ω |
| | | Medium Drive Strength, Ztl = 75 Ω | 40 | 52 | 75 | 125 | |
| | | High Drive Strength, Ztl = 50 Ω | 27 | 35 | 51 | 83 | |
| | | Max Drive Strength, Ztl = 37.5 Ω | 20 | 26 | 38 | 62 | |
| Output Driver Impedance | Rpd | Low Drive Strength, Ztl = 150 Ω | 64 | 88 | 134 | 243 | Ω |
| | | Medium Drive Strength, Ztl = 75 Ω | 32 | 44 | 66 | 122 | |
| | | High Drive Strength, Ztl = 50 Ω | 21 | 30 | 44 | 81 | |
| | | Max Drive Strength, Ztl = 37.5 Ω | 16 | 22 | 34 | 61 | |

4.4.2 DDR2 Output Buffer Impedance

Table 27 shows the DDR2 output buffer impedance.

Table 27. DDR2 I/O Output Buffer Impedance HVE = 0

| Parameter | Symbol | Test Conditions | Best Case T _j = -40 °C OVDD = 1.95 V VCC = 1.3 V | Typical T _j = 25 °C OVDD = 1.8 V VCC = 1.2 V | Worst Case T _j = 105 °C OVDD = 1.6 V VCC = 1.1 V | Unit |
|-------------------------|--------|-----------------------------------|--|--|--|------|
| | | | s0-s5 000000 | s0-s5 101010 | s0-s5 111111 | |
| Output Driver Impedance | Rpu | Low Drive Strength, Ztl = 150 Ω | 185 | 140 | 111.4 | Ω |
| | | Medium Drive Strength, Ztl = 75 Ω | 92.5 | 70 | 55.7 | |
| | | High Drive Strength, Ztl = 50 Ω | 61.7 | 47 | 37.2 | |
| | | Max Drive Strength | 26.5 | 19.5 | 15.4 | |
| Output Driver Impedance | Rpd | Low Drive Strength, Ztl = 150 Ω | 190.3 | 145.4 | 120.6 | Ω |
| | | Medium Drive Strength, Ztl = 75 Ω | 95.1 | 72.7 | 60.3 | |
| | | High Drive Strength, Ztl = 50 Ω | 63.4 | 48.5 | 40.2 | |
| | | Max Drive Strength | 27.6 | 19.9 | 16.9 | |

4.4.3 UHVIO Output Buffer Impedance

Table 28 shows the UHVIO output buffer impedance.

Table 28. UHVIO Output Buffer Impedance

| Parameter | Symbol | Test Conditions | Min | | Typ | | Max | | Unit |
|-------------------------|--------|-----------------------------------|----------------|---------------|-----------------|---------------|----------------|---------------|------|
| | | | OVDD 1.95 V | OVDD 3.0 V | OVDD 1.875 V | OVDD 3.3 V | OVDD 1.65 V | OVDD 3.6 V | |
| Output Driver Impedance | Rpu | Low Drive Strength, Ztl = 150 Ω | 98 | 114 | 124 | 135 | 198 | 206 | Ω |
| | | Medium Drive Strength, Ztl = 75 Ω | 49 | 57 | 62 | 67 | 99 | 103 | |
| | | High Drive Strength, Ztl = 50 Ω | 32 | 38 | 41 | 45 | 66 | 69 | |
| Output Driver Impedance | Rpd | Low Drive Strength, Ztl = 150 Ω | 97 | 118 | 126 | 154 | 179 | 217 | Ω |
| | | Medium Drive Strength, Ztl = 75 Ω | 49 | 59 | 63 | 77 | 89 | 109 | |
| | | High Drive Strength, Ztl = 50 Ω | 32 | 40 | 42 | 51 | 60 | 72 | |

NOTE

Output driver impedance is measured with long transmission line of impedance Ztl attached to I/O pad and incident wave launched into transmission line. Rpu/Rpd and Ztl form a voltage divider that defines specific voltage of incident wave relative to OVDD. Output driver impedance is calculated from this voltage divider (see Figure 3).

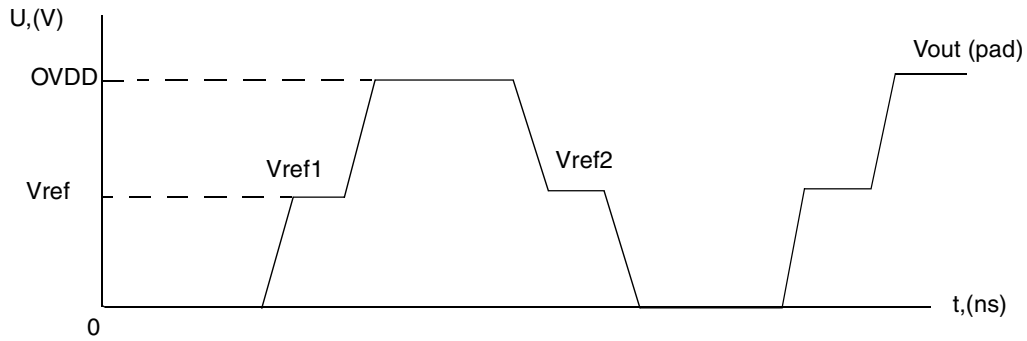
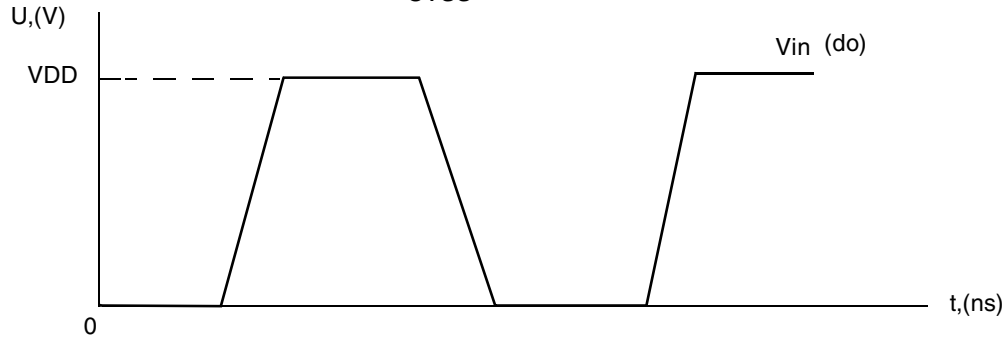
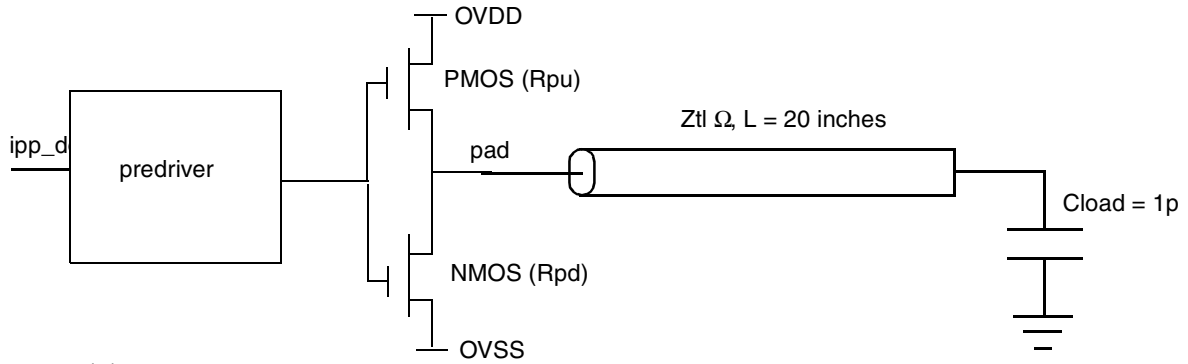

$$R_{pu} = \frac{V_{ovdd} - V_{ref1}}{V_{ref1}} \times Z_{tl}$$

$$R_{pd} = \frac{V_{ref2}}{V_{ovdd} - V_{ref2}} \times Z_{tl}$$

Figure 3. Impedance Matching Load for Measurement

4.5 I/O AC Parameters

The load circuit and output transition time waveforms are shown in [Figure 4](#) and [Figure 5](#). AC electrical characteristics for slow and fast I/O are presented in the [Table 29](#) and [Table 30](#), respectively.

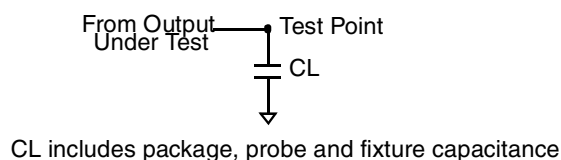

Figure 4. Load Circuit for Output

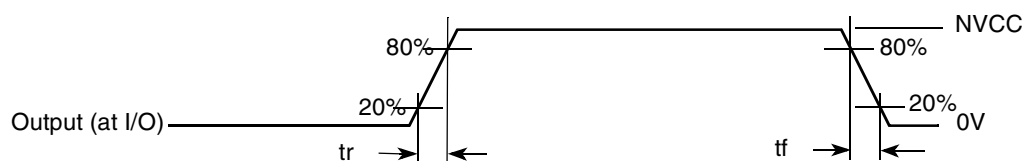

Figure 5. Output Transition Time Waveform

4.5.1 Slow I/O AC Parameters

[Table 29](#) shows the slow I/O AC parameters.

Table 29. Slow I/O AC Parameters

| Parameter | Symbol | Test Condition | Min Rise/Fall | Typ | Max Rise/Fall | Unit |
|--|--------|----------------|------------------------|-----|-------------------------|-------|
| Output Pad Transition Times (Max Drive) | tr, tf | 15 pF 35 pF | — | — | 1.98/1.52 3.08/2.69 | ns |
| Output Pad Transition Times (High Drive) | tr, tf | 15 pF 35 pF | — | — | 2.31/1.838 3.8/2.4 | ns |
| Output Pad Transition Times (Medium Drive) | tr, tf | 15 pF 35 pF | — | — | 2.92/2.43 5.37/4.99 | ns |
| Output Pad Transition Times (Low Drive) | tr, tf | 15 pF 35 pF | — | — | 4.93/4.53 10.55/9.79 | ns |
| Output Pad Slew Rate (Max Drive) | tps | 15 pF 35 pF | 0.5/0.65 0.32/0.37 | — | — | V/ns |
| Output Pad Slew Rate (High Drive) | tps | 15 pF 35 pF | 0.43/0.54 0.26/0.41 | — | — | V/ns |
| Output Pad Slew Rate (Medium Drive) | tps | 15 pF 35 pF | 0.34/0.41 0.18/0.2 | — | — | V/ns |
| Output Pad Slew Rate (Low Drive) | tps | 15 pF 35 pF | 0.20/0.22 0.09/0.1 | — | — | V/ns |
| Output Pad di/dt (Max Drive) | tdit | — | — | — | 30 | mA/ns |
| Output Pad di/dt (High Drive) | tdit | — | — | — | 23 | mA/ns |
| Output Pad di/dt (Medium drive) | tdit | — | — | — | 15 | mA/ns |

Electrical Characteristics

Table 29. Slow I/O AC Parameters (continued)

| Parameter | Symbol | Test Condition | Min Rise/Fall | Typ | Max Rise/Fall | Unit |
|-------------------------------------|--------|----------------|---------------|-----|---------------|-------|
| Output Pad di/dt (Low drive) | tdit | — | — | — | 7 | mA/ns |
| Input Transition Times ¹ | trm | — | — | — | 25 | ns |

¹ Hysteresis mode is recommended for inputs with transition times greater than 25 ns.

4.5.2 Fast I/O AC Parameters

Table 30 shows the fast I/O AC parameters.

Table 30. Fast I/O AC Parameters

| Parameter | Symbol | Test Condition | Min Rise/Fall | Typ | Max Rise/Fall | Unit |
|--|--------|----------------|------------------------|-----|----------------------------|-------|
| Output Pad Transition Times (Max Drive) | tr, tf | 15 pF 35 pF | — | — | 1.429/1.275 2.770/2.526 | ns |
| Output Pad Transition Times (High Drive) | tr, tf | 15 pF 35 pF | — | — | 1.793/1.607 3.565/3.29 | ns |
| Output Pad Transition Times (Medium Drive) | tr, tf | 15 pF 35 pF | — | — | 2.542/2.257 5.252/4.918 | ns |
| Output Pad Transition Times (Low Drive) | tr, tf | 15 pF 35 pF | — | — | 4.641/4.456 10.699/10.0 | ns |
| Output Pad Slew Rate (Max Drive) | tps | 15 pF 35 pF | 0.69/0.78 0.36/0.39 | — | — | V/ns |
| Output Pad Slew Rate (High Drive) | tps | 15 pF 35 pF | 0.55/0.62 0.28/0.30 | — | — | V/ns |
| Output Pad Slew Rate (Medium Drive) | tps | 15 pF 35 pF | 0.39/0.44 0.19/0.20 | — | — | V/ns |
| Output Pad Slew Rate (Low Drive) | tps | 15 pF 35 pF | 0.21/0.22 0.09/0.1 | — | — | V/ns |
| Output Pad di/dt (Max Drive) | tdit | — | — | — | 70 | mA/ns |
| Output Pad di/dt (High Drive) | tdit | — | — | — | 53 | mA/ns |
| Output Pad di/dt (Medium drive) | tdit | — | — | — | 35 | mA/ns |
| Output Pad di/dt (Low drive) | tdit | — | — | — | 18 | mA/ns |
| Input Transition Times ¹ | trm | — | — | — | 25 | ns |

¹ Hysteresis mode is recommended for inputs with transition time greater than 25 ns.

4.5.3 I²C AC Parameters

NOTE

See the errata for HS-I²C in the i.MX51 Chip Errata document. The two standard I²C modules have no errata

Figure 6 depicts the load circuit for output pads for standard- and fast-mode. Figure 7 depicts the output pad transition time definition. Figure 8 depicts load circuit with external pull-up current source for HS-mode. Figure 9 depicts HS-mode timing definition.

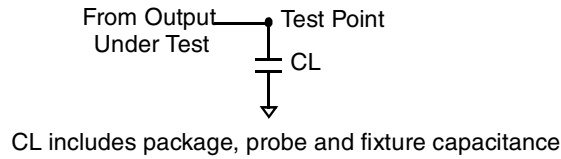
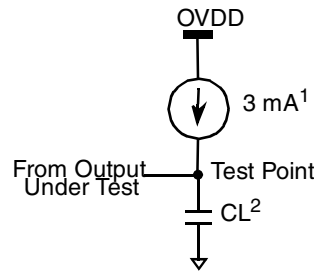

Figure 6. Load Circuit for Standard and Fast-Mode



Figure 7. Definition of Timing for Standard and Fast-Mode



Notes:

- ¹Load current when output is between 0.3×OVDD and 0.7×OVDD
- ²CL includes package, probe, and fixture capacitance.

Figure 8. Load Circuit for HS-Mode with External Pull-Up Current Source

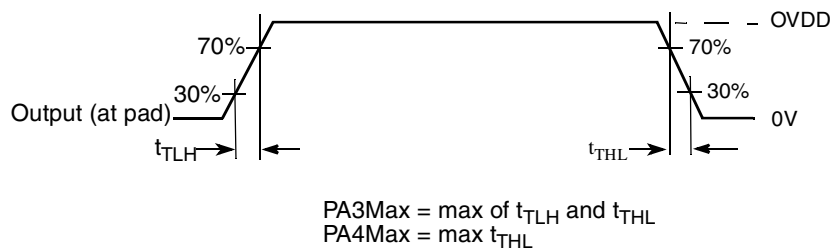

Figure 9. Definition of Timing for HS-Mode

Electrical Characteristics

The electrical characteristics for I²C I/O are listed in Table 31 to Table 34. Characteristics are guaranteed using operating ranges per Table 13, unless otherwise noted.

Table 31. I²C Standard- and Fast-Mode Electrical Parameters for Low/Medium Drive Strength and OVDD = 2.7 V–3.3 V

| Parameter | Symbol | Test Conditions | Min | Typ | Max | Unit |
|--|----------------|--|-----|-----|-----|------|
| Output fall time, (low driver strength) | t _f | from V _{IHmin} to V _{ILmax} with C _L from 10 pF to 400 pF | — | — | 52 | ns |
| Output fall time, (medium driver strength) | t _f | from V _{IHmin} to V _{ILmax} with C _L from 10 pF to 400 pF | — | — | 28 | ns |

Table 32. I²C Standard- and Fast-Mode Electrical Parameters for Low/Medium Drive Strength and OVDD = 1.65 V–1.95 V

| Parameter | Symbol | Test Conditions | Min | Typ | Max | Unit |
|--|-----------------|--|-----|-----|-----|------|
| Output fall time, (low driver strength) | t _{of} | from V _{IHmin} to V _{ILmax} with C _L from 10 pF to 400 pF | — | — | 70 | ns |
| Output fall time, (medium driver strength) | t _{of} | from V _{IHmin} to V _{ILmax} with C _L from 10 pF to 400 pF | — | — | 35 | ns |

Table 33. I²C High-Speed Mode Electrical Parameters for Low/Medium Drive Strength and OVDD = 2.7 V–3.3 V

| Parameter | Symbol | Test Conditions | Min | Typ | Max | Unit |
|--|-------------------------------------|--|-----|-----|-------|------|
| Output rise time (current-source enabled) and fall time at SCLH (low driver strength) | t _{rCL} , t _{fCL} | with a 3mA external pull-up current source and C _L = 100 pF | — | — | 18/21 | ns |
| Output rise time (current-source enabled) and fall time at SCLH (medium driver strength) | t _{rCL} , t _{fCL} | with a 3mA external pull-up current source and C _L = 100 pF | — | — | 9/9 | ns |
| Output fall time at SDAH (low driver strength) | t _{fDA} | with C _L from 10 pF to 100 pF | — | — | 14 | ns |
| Output fall time at SDAH (medium driver strength) | t _{fDA} | with C _L from 10 pF to 100 pF | — | — | 8 | ns |
| Output fall time at SDAH (low driver strength) | t _{fDA} | C _L = 400 pF | — | — | 52 | ns |
| Output fall time at SDAH (medium driver strength) | t _{fDA} | C _L = 400 pF | — | — | 27 | ns |

**Table 34. I²C High-Speed Mode Electrical Parameters
for Low/Medium Drive Strength and OVDD = 1.65 V–1.95 V**

| Parameter | Symbol | Test Conditions | Min | Typ | Max | Unit |
|--|--------------------|--|-----|-----|-------|------|
| Output rise time (current-source enabled) and fall time at SCLH (low driver strength) | t_{rCL}, t_{fCL} | with a 3 mA external pull-up current source and $C_L = 100$ pF | — | — | 10/74 | ns |
| Output rise time (current-source enabled) and fall time at SCLH (medium driver strength) | t_{rCL}, t_{fCL} | with a 3 mA external pull-up current source and $C_L = 100$ pF | — | — | 7/14 | ns |
| Output fall time at SDAH (low driver strength) | t_{fDA} | with C_L from 10 pF to 100 pF | 0 | — | 17 | ns |
| Output fall time at SDAH (medium driver strength) | t_{fDA} | with C_L from 10 pF to 100 pF | 0 | — | 9 | ns |
| Output fall time at SDAH (low driver strength) | t_{fDA} | $C_L = 400$ pF | 30 | — | 67 | ns |
| Output fall time at SDAH (medium driver strength) | t_{fDA} | $C_L = 400$ pF | 15 | — | 34 | ns |

Table 35. Low Voltage I²C I/O Parameters

| Parameter | Symbol | Test Condition | Min Rise/Fall | Typ | Max Rise/Fall | Unit |
|-------------------------------------|--------|----------------|---------------|-----|---------------|-------|
| Output Pad di/dt (Medium drive) | tdit | — | — | — | 22 | mA/ns |
| Output Pad di/dt (Low drive) | tdit | — | — | — | 11 | mA/ns |
| Input Transition Times ¹ | trm | — | — | — | 25 | ns |

¹ Hysteresis mode is recommended for inputs with transition time greater than 25 ns

Table 36. High Voltage I²C I/O Parameters

| Parameter | Symbol | Test Condition | Min Rise/Fall | Typ | Max Rise/Fall | Unit |
|--|--------|----------------|---------------|-----|---------------|-------|
| Output Pad Transition Times (Medium Drive) | tr, tf | 15 pF 35 pF | — | — | 3/3 6/5 | ns |
| Output Pad Transition Times (Low Drive) | tr, tf | 15 pF 35 pF | — | — | 5/5 9/9 | ns |
| Output Pad Slew Rate (Medium Drive) | tps | 15 pF 35 pF | 0/0 0/0 | — | — | V/ns |
| Output Pad Slew Rate (Low Drive) | tps | 15 pF 35 pF | 0/0 0/0 | — | — | V/ns |
| Output Pad di/dt (Medium drive) | tdit | — | — | — | 36 | mA/ns |
| Output Pad di/dt (Low drive) | tdit | — | — | — | 16 | mA/ns |
| Input Transition Times ¹ | trm | — | — | — | 25 | ns |

¹ Hysteresis mode is recommended for inputs with transition time > 25 ns

4.5.4 AC Electrical Characteristics for DDR2

The load circuit for output pads, the output pad transition time waveform and the output pad propagation and transition time waveform are below.

Figure 10 shows the output pad transition time waveform.

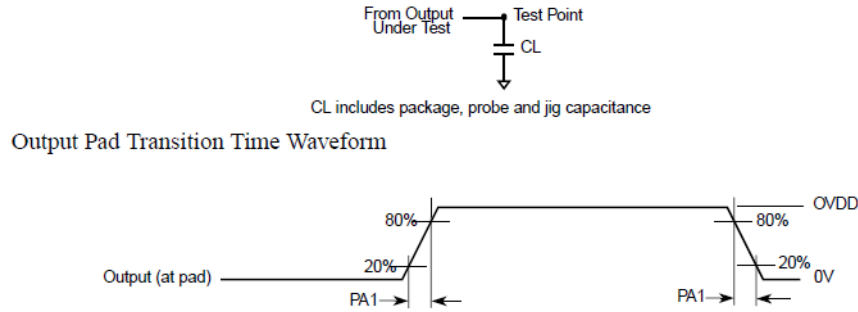

Figure 10. Output Pad Transition Time Waveform

Figure 11 shows the output pad propagation and transition time waveform.

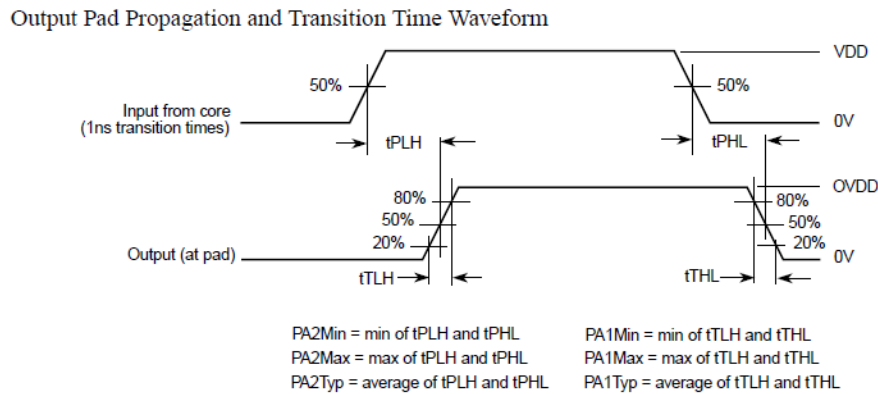

Figure 11. Output Pad Propagation and Transition Time Waveform

AC electrical characteristics in DDR2 mode for fast mode and for ovdd = 1.65 – 1.95 V, ipp_hve = 0 are placed in Table 37.

Table 37. AC Electrical Characteristics of DDR2 IO Pads for Fast mode and for ovdd=1.65–1.95 V (ipp_hve=0)

| Parameter | Symbol | Test Condition | Min rise/fall | Typ | Max rise/fall | Units |
|--|--------|----------------|------------------------|------------------------|------------------------|-------|
| Output Pad Transition Times ¹ | tpr | 15pF 35pF | 0.57/0.57 1.29/1.29 | 0.45/0.44 0.97/0.94 | 0.45/0.45 0.82/0.85 | ns |
| Output Pad Propagation Delay, 50%-50% ¹ | tpo | 15pF 35pF | 0.98/0.96 1.47/1.50 | 1.27/1.19 1.63/1.57 | 1.89/1.72 2.20/2.07 | ns |
| Output Pad Slew Rate ¹ | tps | 15pF 35pF | 2.05/2.05 0.91/0.91 | 2.40/2.45 1.11/1.15 | 2.20/2.20 1.21/1.16 | V/ns |

Table 37. AC Electrical Characteristics of DDR2 IO Pads for Fast mode and for ovdd=1.65–1.95 V (ipp_hve=0) (continued)

| Parameter | Symbol | Test Condition | Min rise/fall | Typ | Max rise/fall | Units |
|---|--------|----------------|---------------|-------------|---------------|-------|
| Output Pad di/dt ¹ | di/dt | — | 390 | 201 | 99 | mA/ns |
| Input Pad Transition Times ² | trfi | 1.2 pF | 0.09/0.09 | 0.132/0.128 | 0.212/0.213 | ns |
| Input Pad Propagation Delay without Hysteresis (CMOS input), 50%-50% ² | tpi | 1.2 pF | 0.45/0.93 | 0.6/0.58 | 0.9/0.88 | ns |
| Input Pad Propagation Delay with Hysteresis (CMOS input), 50%-50% ² | tpi | 1.2 pF | 0.55/0.55 | 0.71/0.7 | 1.03/0.98 | ns |
| Input Pad Propagation Delay (DDR input), 50%-50% ² | tpi | 1.2 pF | 0.38/0.38 | 0.58/0.61 | 1.014/1.07 | ns |
| Maximum Input Transition Times ³ | trm | — | — | — | 5 | ns |

¹ Max condition for tpr, tpo, tps and didt: wcs model, 1.1 V, IO 1.65 V, 105 °C and s0-s5=111111. Typ condition for tpr, tpo, tps and didt: typ model, 1.2 V, IO 1.8 V, 25 °C and s0-s5 = 101010. Min condition for tpr, tpo, tps and didt: bcs model, 1.3 V, IO 1.95 V, -40 °C and s0-s5=000000.

² Max condition for trfi and tpi: wcs model, 1.1 V, IO 1.65 V and 105 °C. Typ condition for trfi and tpi: typ model, 1.2 V, IO 1.8 V and 25 °C. Min condition for trfi and tpi: bcs model, 1.3 V, IO 1.95 V and -40 °C.

³ Hysteresis mode is recommended for input with transition time greater than 25 ns.

AC electrical characteristics in DDR2 mode for Slow mode and for ovdd=1.65 – 1.95 V, ipp_hve = 0 are placed in [Table 38](#):

Table 38. AC Electrical Characteristics of DDR2 IO Pads for Slow Mode and for ovdd=1.65–1.95 V (ipp_hve=0)

| Parameter | Symbol | Test Condition | Min rise/fall | Typ | Max rise/fall | Units |
|---|--------|----------------|------------------------|------------------------|------------------------|-------|
| Output Pad Transition Times ¹ | tpr | 15pF 35pF | 0.75/0.76 1.39/1.40 | 0.70/0.74 1.18/1.21 | 1.06/1.00 1.49/1.47 | ns |
| Output Pad Propagation Delay, 50%-50% ¹ | tpo | 15pF 35pF | 1.50/1.55 2.05/2.16 | 1.90/1.95 2.36/2.48 | 3.23/3.10 3.82/3.75 | ns |
| Output Pad Slew Rate ¹ | tps | 15pF 35pF | 1.56/1.54 0.84/0.84 | 1.54/1.46 0.92/0.89 | 0.93/0.99 0.66/0.67 | V/ns |
| Output Pad di/dt ¹ | di/dt | — | 82 | 40 | 19 | mA/ns |
| Input Pad Transition Times ² | trfi | 1.2 pF | 0.09/0.09 | 0.132/0.128 | 0.212/0.213 | ns |
| Input Pad Propagation Delay without Hysteresis (CMOS input), 50%-50% ² | tpi | 1.2 pF | 0.45/0.93 | 0.6/0.58 | 0.9/0.88 | ns |
| Input Pad Propagation Delay with Hysteresis (CMOS input), 50%-50% ² | tpi | 1.2 pF | 0.55/0.55 | 0.71/0.7 | 1.03/0.98 | ns |
| Input Pad Propagation Delay (DDR input), 50%-50% ² | tpi | 1.2 pF | 0.38/0.38 | 0.58/0.61 | 1.014/1.07 | ns |
| Maximum Input Transition Times ³ | trm | — | — | — | 5 | ns |

Electrical Characteristics

- ¹ Max condition for tpr, tpo, tps and didt: wcs model, 1.1 V, IO 1.65 V, 105 °C and s0-s5=111111. Typ condition for tpr, tpo, tps and didt: typ model, 1.2 V, IO 1.8 V, 25 °C and s0-s5 = 101010. Min condition for tpr, tpo, tps and didt: bcs model, 1.3 V, IO 1.95 V, -40 °C and s0-s5 = 000000.
- ² Max condition for trfi and tpi: wcs model, 1.1 V, IO 1.65 V and 105 °C. Typ condition for trfi and tpi: typ model, 1.2 V, IO 1.8 V and 25 °C. Min condition for trfi and tpi: bcs model, 1.3 V, IO 1.95 V and -40 °C.
- ³ Hysteresis mode is recommended for input with transition time greater than 25 ns.

AC electrical characteristics in DDR mobile for Fast mode and ovdd=1.65 – 1.95 V, ipp_hve=0 are placed in [Table 39](#).

Table 39. AC Electrical Characteristics of DDR mobile IO Pads for Fast Mode and ovdd=1.65–1.95 V (ipp_hve=0)

| Parameter | Symbol | Test Condition | Min rise/fall | Typ | Max rise/fall | Units |
|---|--------|----------------|------------------------|------------------------|------------------------|-------|
| Output Pad Transition Times (High Drive) ¹ | tpr | 15pF 35pF | 1.35/1.31 2.99/2.94 | 1.02/1.03 2.28/2.29 | 0.89/0.89 1.85/1.94 | ns |
| Output Pad Transition Times (Medium Drive) ¹ | tpr | 15pF 35pF | 2.00/1.99 4.55/4.44 | 1.56/1.53 3.38/3.45 | 1.28/1.32 2.79/2.85 | ns |
| Output Pad Transition Times (Low Drive) ¹ | tpr | 15pF 35pF | 4.08/3.92 8.93/8.95 | 3.11/3.06 6.84/6.81 | 2.50/2.61 5.56/5.76 | ns |
| Output Pad Propagation Delay (High Drive) ¹ | tpo | 15pF 35pF | 1.54/1.52 2.69/2.75 | 1.73/1.62 2.59/2.55 | 2.36/2.09 3.04/2.86 | ns |
| Output Pad Propagation Delay (Medium Drive) ¹ | tpo | 15pF 35pF | 2.00/2.02 3.75/3.86 | 2.08/2.00 3.38/3.39 | 2.64/2.40 3.65/3.56 | ns |
| Output Pad Propagation Delay (Low Drive) ¹ | tpo | 15pF 35pF | 3.43/3.52 6.92/7.20 | 3.13/3.13 5.72/5.94 | 3.47/3.34 5.49/5.65 | ns |
| Output Pad Slew Rate (High Drive) ¹ | tps | 15pF 35pF | 0.87/0.89 0.39/0.40 | 1.06/1.05 0.47/0.47 | 1.11/1.11 0.54/0.51 | V/ns |
| Output Pad Slew Rate (Medium Drive) ¹ | tps | 15pF 35pF | 0.58/0.59 0.26/0.26 | 0.69/0.71 0.32/0.31 | 0.77/0.75 0.35/0.35 | V/ns |
| Output Pad Slew Rate (Low Drive) ¹ | tps | 15pF 35pF | 0.29/0.30 0.13/0.13 | 0.35/0.35 0.16/0.16 | 0.40/0.38 0.18/0.17 | V/ns |
| Output Pad di/dt (High Drive) ¹ | di/dt | — | 185 | 91 | 46 | mA/ns |
| Output Pad di/dt (Medium drive) ¹ | di/dt | — | 124 | 61 | 31 | mA/ns |
| Output Pad di/dt (Low drive) ¹ | di/dt | — | 62 | 30 | 16 | mA/ns |
| Input Pad Transition Times ² | trfi | 1.2 pF | 0.09/0.09 | 0.132/0.128 | 0.212/0.213 | ns |
| Input Pad Propagation Delay without Hysteresis (CMOS input), 50%-50% ² | tpi | 1.2 pF | 0.45/0.93 | 0.6/0.58 | 0.9/0.88 | ns |
| Input Pad Propagation Delay with Hysteresis (CMOS input), 50%-50% ² | tpi | 1.2 pF | 0.55/0.55 | 0.71/0.7 | 1.03/0.98 | ns |
| Input Pad Propagation Delay (DDR input), 50%-50% ² | tpi | 1.2 pF | 0.38/0.38 | 0.58/0.61 | 1.014/1.07 | — |
| Maximum Input Transition Times ³ | trm | — | — | — | 5 | ns |

- ¹ Max condition for tpr, tpo, tps and didt: wcs model, 1.1 V, IO 1.65 V, 105 °C and s0-s5=111111. Typ condition for tpr, tpo, tps and didt: typ model, 1.2 V, IO 1.8 V, 25 °C and s0-s5 = 101010. Min condition for tpr, tpo, tps and didt: bcs model, 1.3 V, IO 1.95 V, -40 °C and s0-s5 = 000000.
- ² Max condition for trfi and tpi: wcs model, 1.1 V, IO 1.65 V and 105 °C. Typ condition for trfi and tpi: typ model, 1.2 V, IO 1.8 V and 25 °C. Min condition for trfi and tpi: bcs model, 1.3 V, IO 1.95 V and -40 °C.
- ³ Hysteresis mode is recommended for input with transition time greater than 25 ns.

AC electrical characteristics in DDR mobile for Slow mode and ovdd=1.65-1.95V, ipp_hve=0 are placed in [Table 40](#).

**Table 40. AC Electrical Characteristics of DDR mobile IO Pads for Slow Mode
ovdd=1.65–1.95 V (ipp_hve=0)**

| Parameter | Symbol | Test Condition | Min rise/fall | Typ | Max rise/fall | Units |
|---|--------|----------------|------------------------|------------------------|------------------------|-------|
| Output Pad Transition Times (High Drive) ¹ | tpr | 15pF 35pF | 1.42/1.43 3.03/2.92 | 1.20/1.27 2.39/2.38 | 1.43/1.49 2.35/2.46 | ns |
| Output Pad Transition Times (Medium Drive) ¹ | tpr | 15pF 35pF | 2.04/2.04 4.51/4.49 | 1.68/1.74 3.47/3.50 | 1.82/1.91 3.16/3.30 | ns |
| Output Pad Transition Times (Low Drive) ¹ | tpr | 15pF 35pF | 4.08/3.93 9.06/8.93 | 3.16/3.19 6.92/6.93 | 2.90/3.01 5.74/5.96 | ns |
| Output Pad Propagation Delay (High Drive) ¹ | tpo | 15pF 35pF | 2.00/2.17 3.15/3.42 | 2.33/2.50 3.24/3.52 | 3.70/3.70 4.63/4.75 | ns |
| Output Pad Propagation Delay (Medium Drive) ¹ | tpo | 15pF 35pF | 2.47/2.68 4.2/4.53 | 2.72/2.92 4.01/4.37 | 4.10/4.16 5.33/5.55 | ns |
| Output Pad Propagation Delay (Low Drive) ¹ | tpo | 15pF 35pF | 3.87/4.18 7.32/7.86 | 3.78/4.10 6.35/6.90 | 5.13/5.30 7.25/7.73 | ns |
| Output Pad Slew Rate (High Drive) ¹ | tps | 15pF 35pF | 0.82/0.82 0.39/0.40 | 0.90/0.85 0.45/0.49 | 0.69/0.66 0.42/0.40 | V/ns |
| Output Pad Slew Rate (Medium Drive) ¹ | tps | 15pF 35pF | 0.57/0.57 0.26/0.26 | 0.70/0.62 0.31/0.31 | 0.54/0.52 0.31/0.30 | V/ns |
| Output Pad Slew Rate (Low Drive) ¹ | tps | 15pF 35pF | 0.29/0.30 0.13/0.13 | 0.34/0.34 0.16/0.16 | 0.34/0.33 0.17/0.17 | V/ns |
| Output Pad di/dt (High Drive) ¹ | di/dt | | 47 | 14 | 9 | mA/ns |
| Output Pad di/dt (Medium drive) ¹ | di/dt | — | 27 | 9 | 6 | mA/ns |
| Output Pad di/dt (Low drive) ¹ | di/dt | — | 12 | 5 | 3 | mA/ns |
| Input Pad Transition Times ² | trfi | 1.2 pF | 0.09/0.09 | 0.132/0.128 | 0.212/0.213 | ns |
| Input Pad Propagation Delay without Hysteresis (CMOS input), 50%-50% ² | tpi | 1.2 pF | 0.45/0.93 | 0.6/0.58 | 0.9/0.88 | ns |
| Input Pad Propagation Delay with Hysteresis (CMOS input), 50%-50% ² | tpi | 1.2 pF | 0.55/0.55 | 0.71/0.7 | 1.03/0.98 | ns |
| Input Pad Propagation Delay (DDR input), 50%-50% ² | tpi | 1.2 pF | 0.38/0.38 | 0.58/0.61 | 1.014/1.07 | — |
| Maximum Input Transition Times ³ | trm | — | — | — | 5 | ns |

Electrical Characteristics

- ¹ Max condition for tpr, tpo, tps and didt: wcs model, 1.1 V, IO 1.65 V, 105 °C and s0-s5=111111. Typ condition for tpr, tpo, tps and didt: typ model, 1.2 V, IO 1.8 V, 25 °C and s0-s5=101010. Min condition for tpr, tpo, tps and didt: bcs model, 1.3 V, IO 1.95 V, -40 °C and s0-s5=000000.
- ² Max condition for trfi and tpi: wcs model, 1.1 V, IO 1.65 V and 105 °C. Typ condition for trfi and tpi: typ model, 1.2 V, IO 1.8 V and 25 °C. Min condition for trfi and tpi: bcs model, 1.3 V, IO 1.95 V and -40 °C.
- ³ Hysteresis mode is recommended for input with transition time greater than 25 ns.

AC electrical characteristics in DDR2 mode for Fast mode and for ovdd=1.65–1.95V, ipp_hve=0 are placed in [Table 41](#).

Table 41. AC Electrical Characteristics of DDR2_clk IO Pads for Fast mode and for ovdd=1.65–1.95 V

| Parameter | Symbol | Test Condition | Min rise/fall | Typ | Max rise/fall | Units |
|---|--------|----------------|------------------------|------------------------|------------------------|-------|
| Output Pad Transition Times ¹ | tpr | 15pF 35pF | 0.58/0.57 1.29/1.28 | 0.45/0.44 0.97/0.93 | 0.45/0.45 0.82/0.85 | ns |
| Output Pad Propagation Delay, 50%-50% ¹ | tpo | 15pF 35pF | 1.05/1.03 1.54/1.56 | 1.40/1.31 1.75/1.69 | 2.12/1.96 2.43/2.31 | ns |
| Output Pad Slew Rate ¹ | tps | 15pF 35pF | 2.02/2.05 0.91/0.91 | 2.40/2.45 1.11/1.16 | 2.20/2.20 1.21/1.16 | V/ns |
| Output Pad di/dt ¹ | di/dt | — | 390 | 201 | 99 | mA/ns |
| Input Pad Transition Times ² | trfi | 1.2 pF | 0.09/0.09 | 0.132/0.128 | 0.212/0.213 | ns |
| Input Pad Propagation Delay (DDR input), 50%-50% ² | tpi | 1.2 pF | 0.3/0.36 | 0.5/0.52 | 0.82/0.94 | ns |
| Maximum Input Transition Times ³ | trm | — | — | — | 5 | ns |

- ¹ Max condition for tpr, tpo, tps and didt: wcs model, 1.1 V, IO 1.65 V, 105 °C and s0-s5=111111. Typ condition for tpr, tpo, tps and didt: typ model, 1.2 V, IO 1.8 V, 25 °C and s0-s5=101010. Min condition for tpr, tpo, tps and didt: bcs model, 1.3 V, IO 1.95 V, -40 °C and s0-s5=000000.
- ² Max condition for trfi and tpi: wcs model, 1.1 V, IO 1.65 V and 105 °C. Typ condition for trfi and tpi: typ model, 1.2 V, IO 1.8 V and 25 °C. Min condition for trfi and tpi: bcs model, 1.3 V, IO 1.95 V and -40 °C.
- ³ Hysteresis mode is recommended for input with transition time greater than 25 ns.

AC electrical characteristics in DDR2 mode for Slow mode and for ovdd=1.65-1.95V, ipp_hve=0 are placed in [Table 42](#).

Table 42. AC Electrical Characteristics of DDR2_clk IO Pads for Slow mode and for ovdd=1.65 – 1.95 V (ipp_hve=0)

| Parameter | Symbol | Test Condition | Min rise/fall | Typ | Max rise/fall | Units |
|--|--------|----------------|------------------------|------------------------|------------------------|-------|
| Output Pad Transition Times ¹ | tpr | 15pF 35pF | 0.74/0.76 1.40/1.39 | 0.69/0.72 1.18/1.20 | 1.04/1.01 1.48/1.47 | ns |
| Output Pad Propagation Delay, 50%-50% ¹ | tpo | 15pF 35pF | 1.56/1.61 2.12/2.22 | 2.02/2.08 2.49/2.61 | 3.45/3.33 4.05/3.98 | ns |
| Output Pad Slew Rate ¹ | tps | 15pF 35pF | 1.58/1.54 0.84/0.84 | 1.57/1.50 0.92/0.90 | 0.95/0.98 0.67/0.67 | V/ns |

Table 42. AC Electrical Characteristics of DDR2_clk IO Pads for Slow mode and for ovdd=1.65 – 1.95 V (ipp_hve=0) (continued)

| Parameter | Symbol | Test Condition | Min rise/fall | Typ | Max rise/fall | Units |
|---|--------|----------------|---------------|-------------|---------------|-------|
| Output Pad di/dt ¹ | di/dt | — | 82 | 40 | 19 | mA/ns |
| Input Pad Transition Times ² | trfi | 1.2 pF | 0.09/0.09 | 0.132/0.128 | 0.212/0.213 | ns |
| Input Pad Propagation Delay (DDR input), 50%-50% ² | tpi | 1.2 pF | 0.3/0.36 | 0.5/0.52 | 0.82/0.94 | ns |
| Maximum Input Transition Times ³ | trm | — | — | — | 5 | ns |

¹ Max condition for tpr, tpo, tps and didt: wcs model, 1.1 V, IO 1.65 V, 105 °C and s0-s5=111111. Typ condition for tpr, tpo, tps and didt: typ model, 1.2 V, IO 1.8 V, 25 °C and s0-s5=101010. Min condition for tpr, tpo, tps and didt: bcs model, 1.3 V, IO 1.95 V, -40 °C and s0-s5=000000.

² Max condition for trfi and tpi: wcs model, 1.1 V, IO 1.65 V and 105 °C. Typ condition for trfi and tpi: typ model, 1.2 V, IO 1.8 V and 25 °C. Min condition for trfi and tpi: bcs model, 1.3 V, IO 1.95 V and -40 °C.

³ Hysteresis mode is recommended for input with transition time greater than 25 ns.

AC electrical characteristics in DDR mobile for Fast mode and ovdd=1.65-1.95V, ipp_hve=0 are placed in [Table 43](#).

Table 43. AC Electrical Characteristics of DDR_clk mobile IO Pads for Fast mode and ovdd=1.65 – 1.95 V (ipp_hve=0)

| Parameter | Symbol | Test Condition | Min rise/fall | Typ | Max rise/fall | Units |
|--|--------|----------------|------------------------|------------------------|------------------------|-------|
| Output Pad Transition Times (High Drive) ¹ | tpr | 15pF 35pF | 1.35/1.32 3.01/2.96 | 1.03/1.03 2.29/2.30 | 0.89/0.89 1.84/1.92 | ns |
| Output Pad Transition Times (Medium Drive) ¹ | tpr | 15pF 35pF | 1.98/1.98 4.52/4.38 | 1.55/1.54 3.46/3.45 | 1.29/1.30 2.80/2.88 | ns |
| Output Pad Transition Times (Low Drive) ¹ | tpr | 15pF 35pF | 3.99/3.94 8.93/8.86 | 3.10/3.04 6.77/6.85 | 2.50/2.57 5.40/5.68 | ns |
| Output Pad Propagation Delay (High Drive) ¹ | tpo | 15pF 35pF | 1.60/1.58 2.74/2.81 | 1.85/1.74 2.71/2.67 | 2.58/2.31 3.26/3.08 | ns |
| Output Pad Propagation Delay (Medium Drive) ¹ | tpo | 15pF 35pF | 2.07/2.08 3.79/3.92 | 2.19/2.12 3.46/3.51 | 2.86/2.62 3.87/3.77 | ns |
| Output Pad Propagation Delay (Low Drive) ¹ | tpo | 15pF 35pF | 3.47/3.57 6.94/7.26 | 3.23/3.25 5.84/6.06 | 3.69/3.55 5.73/5.87 | ns |
| Output Pad Slew Rate (High Drive) ¹ | tps | 15pF 35pF | 0.87/0.89 0.39/0.40 | 1.05/1.05 0.47/0.47 | 1.11/1.11 0.54/0.52 | V/ns |
| Output Pad Slew Rate (Medium Drive) ¹ | tps | 15pF 35pF | 0.59/0.59 0.26/0.27 | 0.70/0.70 0.31/0.31 | 0.77/0.76 0.35/0.34 | V/ns |
| Output Pad Slew Rate (Low Drive) ¹ | tps | 15pF 35pF | 0.29/0.30 0.13/0.13 | 0.35/0.36 0.16/0.16 | 0.40/0.39 0.18/0.17 | V/ns |
| Output Pad di/dt (High Drive) ¹ | di/dt | — | 185 | 91 | 46 | mA/ns |
| Output Pad di/dt (Medium drive) ¹ | di/dt | — | 124 | 61 | 31 | mA/ns |

Electrical Characteristics

Table 43. AC Electrical Characteristics of DDR_clk mobile IO Pads for Fast mode and ovdd=1.65 – 1.95 V (ipp_hve=0) (continued)

| Parameter | Symbol | Test Condition | Min rise/fall | Typ | Max rise/fall | Units |
|---|--------|----------------|---------------|-------------|---------------|-------|
| Output Pad di/dt (Low drive) ¹ | di/dt | — | 62 | 30 | 16 | mA/ns |
| Input Pad Transition Times ² | trfi | 1.2 pF | 0.09/0.09 | 0.132/0.128 | 0.212/0.213 | ns |
| Input Pad Propagation Delay (DDR input), 50%-50% ² | tpi | 1.2 pF | 0.3/0.36 | 0.5/0.52 | 0.82/0.94 | — |
| Maximum Input Transition Times ³ | trm | — | — | — | 5 | ns |

¹ Max condition for tpr, tpo, tps and didt: wcs model, 1.1 V, IO 1.65 V, 105 °C and s0-s5=111111. Typ condition for tpr, tpo, tps and didt: typ model, 1.2 V, IO 1.8 V, 25 °C and s0-s5=101010. Min condition for tpr, tpo, tps and didt: bcs model, 1.3 V, IO 1.95 V, -40 °C and s0-s5=000000.

² Max condition for trfi and tpi: wcs model, 1.1 V, IO 1.65 V and 105 °C. Typ condition for trfi and tpi: typ model, 1.2 V, IO 1.8 V and 25 °C. Min condition for trfi and tpi: bcs model, 1.3 V, IO 1.95 V and -40 °C.

³ Hysteresis mode is recommended for input with transition time greater than 25 ns.

AC electrical characteristics in DDR mobile for Slow mode and ovdd=1.65-1.95V, ipp_hve=0 are placed in [Table 44](#).

Table 44. AC Electrical Characteristics of DDR mobile IO Pads for Slow Mode and ovdd=1.65 – 1.95 V (ipp_hve=0)

| Parameter | Symbol | Test Condition | Min rise/fall | Typ | Max rise/fall | Units |
|--|--------|----------------|------------------------|------------------------|-------------------------|-------|
| Output Pad Transition Times (High Drive) ¹ | tpr | 15pF 35pF | 1.42/1.42 3.01/2.96 | 1.20/1.27 2.38/2.40 | 1.43/1.49 2.37/2.44 | ns |
| Output Pad Transition Times (Medium Drive) ¹ | tpr | 15pF 35pF | 2.05/2.04 4.50/4.42 | 1.67/1.71 3.48/3.52 | 1.82/1.87 3.16/3.28 | ns |
| Output Pad Transition Times (Low Drive) ¹ | tpr | 15pF 35pF | 4.06/3.98 8.94/8.86 | 3.15/3.17 6.92/6.93 | 2.92/ 3.02 5.69/5.96 | ns |
| Output Pad Propagation Delay (High Drive) ¹ | tpo | 15pF 35pF | 2.07/2.23 3.21/3.48 | 2.46/2.62 3.35/3.63 | 3.92/3.93 4.84/4.97 | ns |
| Output Pad Propagation Delay (Medium Drive) ¹ | tpo | 15pF 35pF | 2.53/2.74 4.26/4.58 | 2.83/3.04 4.12/4.49 | 4.32/4.35 5.55/5.76 | ns |
| Output Pad Propagation Delay (Low Drive) ¹ | tpo | 15pF 35pF | 3.93/4.23 7.38/7.91 | 3.89/4.21 6.43/7.01 | 5.37/5.51 7.45/7.94 | ns |
| Output Pad Slew Rate (High Drive) ¹ | tps | 15pF 35pF | 0.82/0.82 0.39/0.40 | 0.90/0.85 0.45/0.45 | 0.69/0.66 0.42/0.41 | V/ns |
| Output Pad Slew Rate (Medium Drive) ¹ | tps | 15pF 35pF | 0.57/0.57 0.26/0.26 | 0.65/0.63 0.31/0.31 | 0.54/0.53 0.31/0.30 | V/ns |
| Output Pad Slew Rate (Low Drive) ¹ | tps | 15pF 35pF | 0.29/0.29 0.13/0.13 | 0.34/0.34 0.16/0.16 | 0.34/0.33 0.17/0.17 | V/ns |
| Output Pad di/dt (High Drive) ¹ | di/dt | — | 47 | 14 | 9 | mA/ns |
| Output Pad di/dt (Medium drive) ¹ | di/dt | — | 27 | 9 | 6 | mA/ns |

Table 44. AC Electrical Characteristics of DDR mobile IO Pads for Slow Mode and ovdd=1.65 – 1.95 V (ipp_hve=0) (continued)

| Parameter | Symbol | Test Condition | Min rise/fall | Typ | Max rise/fall | Units |
|---|--------|----------------|---------------|-------------|---------------|-------|
| Output Pad di/dt (Low drive) ¹ | di/dt | — | 12 | 5 | 3 | mA/ns |
| Input Pad Transition Times ² | trfi | 1.2 pF | 0.09/0.09 | 0.132/0.128 | 0.212/0.213 | ns |
| Input Pad Propagation Delay (DDR input), 50%-50% ² | tpi | 1.2 pF | 0.3/0.36 | 0.5/0.52 | 0.82/0.94 | — |
| Maximum Input Transition Times ³ | trm | — | — | — | 5 | ns |

¹ Max condition for tpr, tpo, tps and didt: wcs model, 1.1 V, IO 1.65 V, 105 °C and s0-s5=111111. Typ condition for tpr, tpo, tps and didt: typ model, 1.2 V, IO 1.8 V, 25 °C and s0-s5=101010. Min condition for tpr, tpo, tps and didt: bcs model, 1.3 V, IO 1.95 V, -40 °C and s0-s5=000000.

² Max condition for trfi and tpi: wcs model, 1.1 V, IO 1.65 V and 105 °C. Typ condition for trfi and tpi: typ model, 1.2 V, IO 1.8 V and 25 °C. Min condition for trfi and tpi: bcs model, 1.3 V, IO 1.95 V and -40 °C.

³ Hysteresis mode is recommended for input with transition time greater than 25 ns.

4.6 Module Timing

This section contains the timing and electrical parameters for the modules in the i.MX51 processor.

4.6.1 Reset Timings Parameters

Figure 12 shows the reset timing and Table 45 lists the timing parameters.

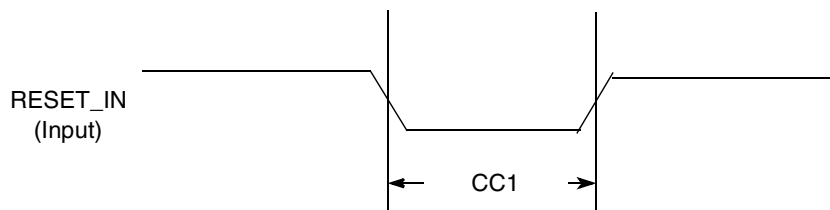

Figure 12. Reset Timing Diagram

Table 45. Reset Timing Parameters

| ID | Parameter | Min | Max | Unit |
|-----|--|-----|-----|------|
| CC1 | Duration of RESET_IN to be qualified as valid (input slope = 5 ns) | 50 | — | ns |

4.6.2 WDOG Reset Timing Parameters

Figure 13 shows the WDOG reset timing and Table 46 lists the timing parameters.

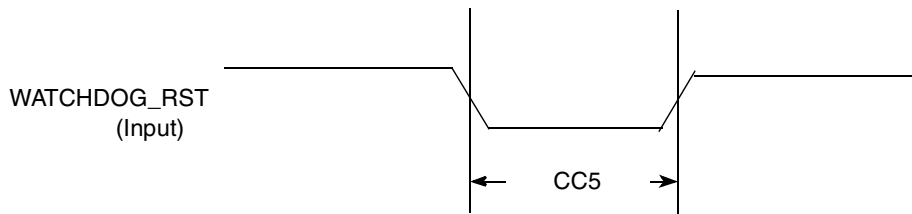

Figure 13. WATCHDOG_RST Timing Diagram

Table 46. WATCHDOG_RST Timing Parameters

| ID | Parameter | Min | Max | Unit |
|-----|--------------------------------------|-----|-----|------------|
| CC5 | Duration of WATCHDOG_RESET Assertion | 1 | — | T_{CKIL} |

NOTE

CKIL is approximately 32 kHz. T_{CKIL} is one period or approximately 30 μ s.

4.6.3 AUDMUX Timing Parameters

The AUDMUX provides a programmable interconnect logic for voice, audio and data routing between internal serial interfaces (SSIs) and external serial interfaces (audio and voice codecs). The AC timing of AUDMUX external pins is hence governed by the SSI module.

4.6.4 Clock Amplifier Parameters (CKIH1, CKIH2)

The input to Clock Amplifier (CAMP) is internally ac-coupled allowing direct interface to a square wave or sinusoidal frequency source. No external series capacitors are required. Table 47 shows the CAMP electrical parameters.

Table 47. CAMP Electrical Parameters (CKIH1, CKIH2)

| Parameter | Min | Typ | Max | Unit |
|-----------------------------|------------------|-----|-----------|------------------|
| Input frequency | 8.0 | — | 40.0 | MHz |
| VIL (for square wave input) | 0 | — | 0.3 | V |
| VIH (for square wave input) | NVCC_PER3 - 0.25 | — | NVCC_PER3 | V |
| Sinusoidal input amplitude | 0.4 | — | VDD | V _{p-p} |
| Output duty cycle | 45 | 50 | 55 | % |

4.6.5 DPLL Electrical Parameters

Table 48 shows the DPLL electrical parameters.

Table 48. DPLL Electrical Parameters

| Parameter | Test Conditions/Remarks | Min | Typ | Max | Unit |
|--|--|-----------|------|---|--------------|
| Reference clock frequency range ¹ | — | 10 | — | 100 | MHz |
| Reference clock frequency range after pre-divider | — | 10 | — | 40 | MHz |
| Output clock frequency range (dpdck_2) | — | 300 | — | 1025 | MHz |
| Pre-division factor ² | — | 1 | — | 16 | — |
| Multiplication factor integer part | — | 5 | — | 15 | — |
| Multiplication factor numerator ³ | Should be less than denominator | -67108862 | — | 67108862 | — |
| Multiplication factor denominator ² | — | 1 | — | 67108863 | — |
| Output Duty Cycle | — | 48.5 | 50 | 51.5 | % |
| Frequency lock time ⁴ (FOL mode or non-integer MF) | — | — | — | 398 | T_{dpdref} |
| Phase lock time | — | — | — | 100 | μ s |
| Frequency jitter ⁵ (peak value) | — | — | 0.02 | 0.04 | T_{dck} |
| Phase jitter (peak value) | FPL mode, integer and fractional MF | — | 2.0 | 3.5 | ns |
| Power dissipation | $f_{dck} = 300$ MHz @ avdd = 1.8 V, dvdd = 1.2 V $f_{dck} = 650$ MHz @ avdd = 1.8 V, dvdd = 1.2 V | — | — | 0.65 (avdd) 0.92 (dvdd) 1.98 (avdd) 1.8 (dvdd) | mW |

¹ Device input range cannot exceed the electrical specifications of the CAMP, see Table 47.

² The values specified here are internal to DPLL. Inside the DPLL, a “1” is added to the value specified by the user. Therefore, the user has to enter a value “1” less than the desired value at the inputs of DPLL for PDF and MFD.

³ The maximum total multiplication factor (MFI + MFN/MFD) allowed is 15. Therefore, if the MFI value is 15, MFN value must be zero.

⁴ T_{dpdref} is the time period of the reference clock after predivider. According to the specification, the maximum lock time in FOL mode is 398 cycles of divided reference clock when DPLL starts after full reset.

⁵ T_{dck} is the time period of the output clock, dpdck_2.

4.6.6 NAND Flash Controller (NFC) Parameters

This section provides the relative timing requirements among different signals of NFC at the module level in the different operational modes.

Timing parameters in Figure 14, Figure 15, Figure 16, Figure 17, Figure 19, and Table 50 show the default NFC mode (asymmetric mode) using two Flash clock cycles per one access of RE_B and WE_B. Timing parameters in Figure 14, Figure 15, Figure 16, Figure 18, Figure 19, and Table 50 show symmetric NFC mode using one Flash clock cycle per one access of RE_B and WE_B.

Electrical Characteristics

With reference to the timing diagrams, a high is defined as 80% of signal value and low is defined as 20% of signal value. All parameters are given in nanoseconds. The BGA contact load used in calculations is 20 pF (except for NF16 - 40 pF) and there is max drive strength on all contacts.

All timing parameters are a function of T, which is the period of the flash_clk clock (“enfc_clk” at system level). This clock frequency can be controlled by the user, configuring CCM (SoC clock controller). The clock is derived from emi_slow_clk after single divider. Table 49 demonstrates few examples for clock frequency settings.

Table 49. NFC Clock Settings Examples

| emi_slow_clk (MHz) | nfc_podf (Division Factor) | enfc_clk (MHz) | T—Clock Period (ns) ¹ |
|--------------------|----------------------------|----------------|----------------------------------|
| 133 (max value) | 5 (reset value) | 26.6 | 38 |
| 133 | 4 | 33.25 | 31 |
| 133 | 3 | 44.33 | 23 |

¹ Rounded up to whole nanoseconds.

NOTE

A potential limitation for minimum clock frequency may exist for some devices. When the clock frequency is too low the actual data bus capturing might occur after the specified trhoh (RE_B high to output hold) period. Setting the clock frequency above 25.6 MHz (T = 39 ns) guarantees proper operation for devices having trhoh > 15 ns. It is also recommended to set the NFC_FREQ_SEL Fuse accordingly to initiate the boot with 33.33 MHz clock.

Lower frequency operation can be supported for most available devices in the market, relying on data lines Bus-Keeper logic. This depends on device behavior on the data bus in the time interval between data output valid to data output high-Z state. In NAND device parameters this period is marked between trhoh and trhz (RE_B high to output high-Z). In most devices, the data transition from valid value to high-Z occurs without going through other states. Setting the data bus pads to Bus-Keeper mode in the IOMUX registers, keeps the data bus valid internally after the specified hold time, allowing proper capturing with slower clock.

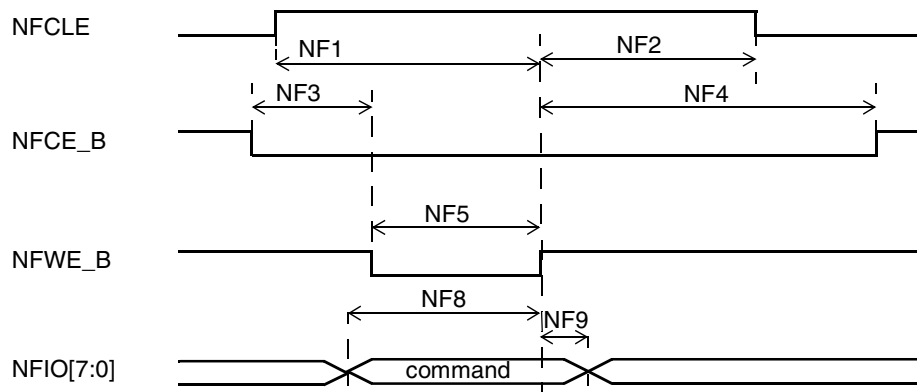

Figure 14. Command Latch Cycle Timing

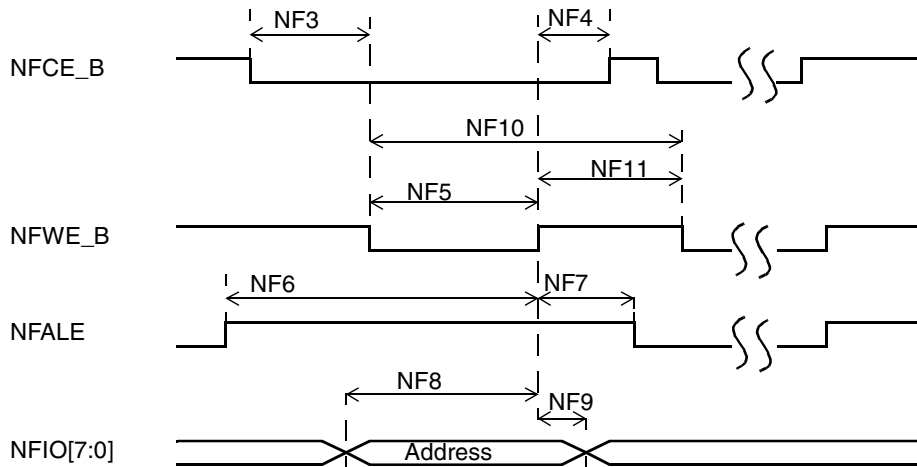

Figure 15. Address Latch Cycle Timing

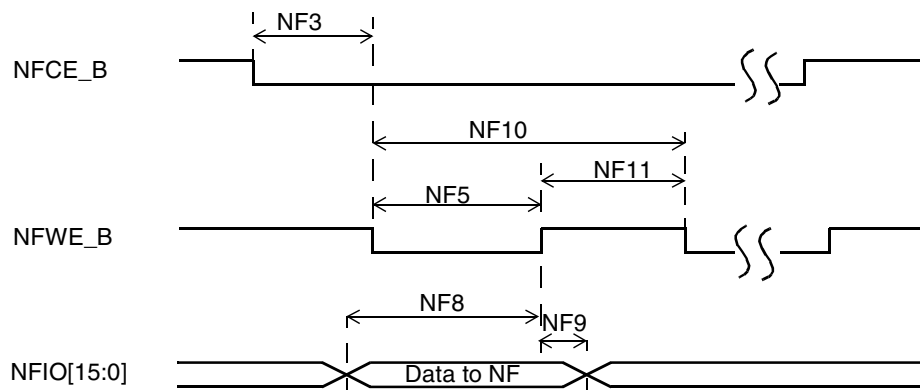

Figure 16. Write Data Latch Timing

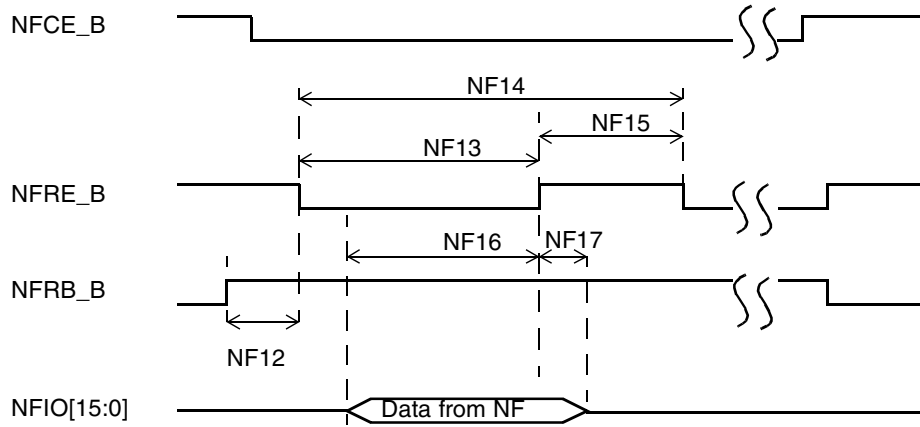

Figure 17. Read Data Latch Timing—Asymmetric Mode

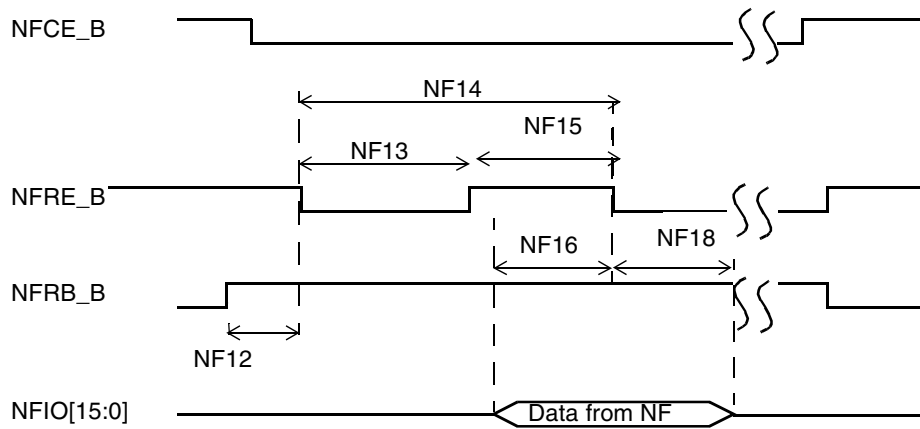

Figure 18. Read Data Latch Timing—Symmetric Mode

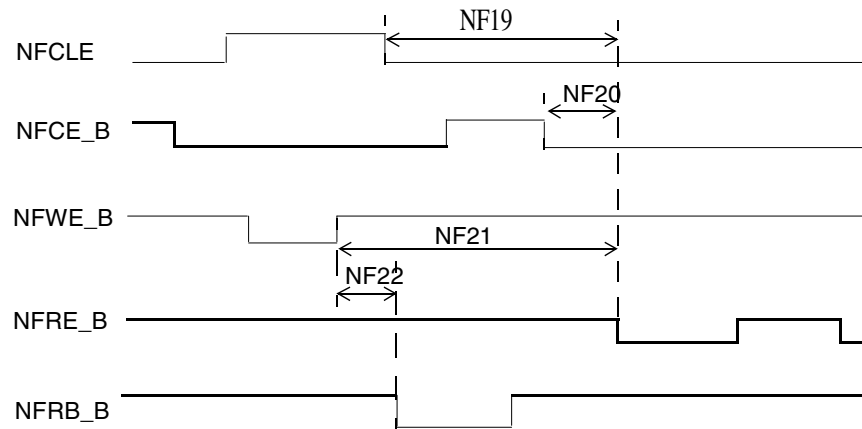

Figure 19. Other Timing Parameters

Table 50. NFC—Timing Characteristics

| ID | Parameter | Symbol | Asymmetric Mode Min | Symmetric Mode Min | Max |
|-------------------|-----------------------|--------|---------------------|--------------------|--------------|
| NF1 | NFCLE setup Time | tCLS | 2T-1 | 2T-1 | — |
| NF2 | NFCLE Hold Time | tCLH | T-4.45 | T-4.45 | — |
| NF3 | NFCE_B Setup Time | tCS | 2T-1 | T-1 | — |
| NF4 | NFCE_B Hold Time | tCH | 2T-5.55 | 0.5T-5.55 | — |
| NF5 | NFWE_B Pulse Width | tWP | T-2.5 | 0.5T-1.5 | — |
| NF6 | NFALE Setup Time | tALS | 2T-2.7 | 2T-2.7 | — |
| NF7 | NFALE Hold Time | tALH | T-4.45 | T-4.45 | — |
| NF8 | Data Setup Time | tDS | T-2.25 | 0.5T-2.25 | — |
| NF9 | Data Hold Time | tDH | T-6.55 | 0.5T-5.55 | — |
| NF10 | Write Cycle Time | tWC | 2T | T | — |
| NF11 | NFWE_B Hold Time | tWH | T-1.25 | 0.5T-1.25 | — |
| NF12 | Ready to NFRE_B Low | tRR | 9T | 9T | — |
| NF13 | NFRE_B Pulse Width | tRP | 1.5T-2.7 | 0.5T | — |
| NF14 | READ Cycle Time | tRC | 2T | T | — |
| NF15 | NFRE_B High Hold Time | tREH | 0.5T-1.5 | 0.5T-1.5 | — |
| NF16 ¹ | Data Setup on READ | tDSR | $11.2+0.5T-Tdl^2$ | $11.2-Tdl^2$ | — |
| NF17 ³ | Data Hold on READ | tDHR | 0 | — | $2T_{ack}+T$ |
| NF18 ⁴ | Data Hold on READ | tDHR | — | Tdl^2 | $2T_{ack}+T$ |
| NF19 | CLE to RE delay | tCLR | 13T | 13T | — |
| NF20 | CE to RE delay | tCRE | T-3.45 | 1.5T-3.45 | — |

Table 50. NFC—Timing Characteristics (continued)

| ID | Parameter | Symbol | Asymmetric Mode Min | Symmetric Mode Min | Max |
|------|-------------------|--------|---------------------|--------------------|-----|
| NF21 | WE high to RE low | tWHR | 14T-5.45 | 14T-5.45 | — |
| NF22 | WE high to busy | tWB | — | — | 6T |

- ¹ tDSR is calculated by the following formula:
 Asymmetric mode: $t_{DSR} = t_{REpd} + t_{Dpd} + \frac{1}{2}T - TdI^2$
 Symmetric mode: $t_{DSR} = t_{REpd} + t_{Dpd} - TdI^2$
 $t_{REpd} + t_{Dpd} = 11.2$ ns (including clock skew)
 where tREpd is RE propagation delay in the chip including IO pad delay, and tDpd is Data propagation delay from IO pad to EMI including IO pad delay.
 tDSR can be used to determine tREA max parameter with the following formula: $t_{REA} = 1.5T - t_{DSR}$.
- ² TdI is composed of 4 delay-line units each generates an equal delay with min 1.25 ns and max 1 aclk period (Tack). Default is 1/4 aclk period for each delay-line unit, so all 4 delay lines together generates a total of 1 aclk period. Tack is “emi_slow_clk” of the system, which default value is 7.5 ns (133 MHz).
- ³ NF17 is defined only in asymmetric operation mode.
 NF17 max value is equivalent to max tRHZ value that can be used with NFC.
 Tack is “emi_slow_clk” of the system.
- ⁴ NF18 is defined only in Symmetric operation mode.
 tDHR (MIN) is calculated by the following formula: $TdI^2 - (t_{REpd} + t_{Dpd})$
 where tREpd is RE propagation delay in the chip including IO pad delay, and tDpd is Data propagation delay from IO pad to EMI including IO pad delay.
 NF18 max value is equivalent to max tRHZ value that can be used with NFC.
 Tack is “emi_slow_clk” of the system.

4.6.7 External Interface Module (WEIM)

The following sections provide information on the WEIM.

4.6.7.1 WEIM Signal Cross Reference

Table 51 is a guide to help the user identify signals in the WEIM Chapter of the *i.MX51 Multimedia Applications Processor Reference Manual (MCIMX51RM)* that are the same as those mentioned in this data sheet.

Table 51. WEIM Signal Cross Reference

| Reference Manual WEIM Chapter Nomenclature | Data Sheet Nomenclature, Reference Manual External Signals and Pin Multiplexing Chapter, and IOMUX Controller Chapter Nomenclature |
|--|--|
| BCLK | EIM_BCLK |
| CSx | EIM_CSx |
| WE_B | EIM_RW |
| OE_B | EIM_OE |
| BEy_B | EIM_EBx |
| ADV | EIM_LBA |

Table 51. WEIM Signal Cross Reference (continued)

| Reference Manual WEIM Chapter Nomenclature | Data Sheet Nomenclature, Reference Manual External Signals and Pin Multiplexing Chapter, and IOMUX Controller Chapter Nomenclature |
|--|--|
| ADDR | EIM_A[27:16], EIM_DA[15:0] |
| ADDR/M_DATA | EIM_DA _x (Addr/Data muxed mode) |
| DATA | EIM_NFC_D (Data bus shared with NAND Flash) EIM_D _x (dedicated data bus) |
| WAIT_B | EIM_WAIT |

4.6.7.2 WEIM Internal Module Multiplexing

Table 52 provides WEIM internal muxing information.

Table 52. WEIM Interface Pinout in Various Configurations

| | Non Multiplexed Address/Data Mode (MUM=0) | | | | | | | Multiplexed Address/Data Mode (MUM=1) | |
|-------------------|---|-----------------|------------------------------|-----------------|------------------|------------------|------------------|---------------------------------------|------------------|
| | 8-Bit (DSZ=100) | 8-Bit (DSZ=101) | 8-Bit ¹ (DSZ=110) | 8-Bit (DSZ=111) | 16-Bit (DSZ=001) | 16-Bit (DSZ=010) | 32-Bit (DSZ=011) | 16-Bit (DSZ=001) | 32-Bit (DSZ=011) |
| A[15:0] | EIM_DA [15:0] | EIM_DA [15:0] | EIM_DA [15:0] | EIM_DA [15:0] | EIM_DA [15:0] | EIM_DA [15:0] | EIM_DA [15:0] | EIM_DA [15:0] | EIM_DA [15:0] |
| A[27:16] | EIM_A [27:16] | EIM_A [27:16] | EIM_A [27:16] | EIM_A [27:16] | EIM_A [27:16] | EIM_A [27:16] | EIM_A [27:16] | EIM_A [27:16] | NANDF_D [11:0] |
| D[7:0], EIM_EB0 | NANDF_D [7:0] | — | — | — | NANDF_D [7:0] | — | NANDF_D [7:0] | EIM_DA [7:0] | EIM_DA [7:0] |
| D[15:8], EIM_EB1 | — | NANDF_D [15:8] | — | — | NANDF_D [15:8] | — | NANDF_D [15:8] | EIM_DA [15:8] | EIM_DA [15:8] |
| D[23:16], EIM_EB2 | — | — | EIM_D [23:16] | — | — | EIM_D [23:16] | EIM_D [23:16] | — | NANDF_D [7:0] |
| D[31:24], EIM_EB3 | — | — | — | EIM_D [31:24] | — | EIM_D [31:24] | EIM_D [31:24] | — | NANDF_D [15:8] |

¹ This mode is not supported due to erratum ENGcm11244.

4.6.7.3 General WEIM Timing-Synchronous Mode

Figure 20, Figure 21, and Table 53 specify the timings related to the WEIM module. All WEIM output control signals may be asserted and deasserted by an internal clock synchronized to the BCLK rising edge according to corresponding assertion/negation control fields.

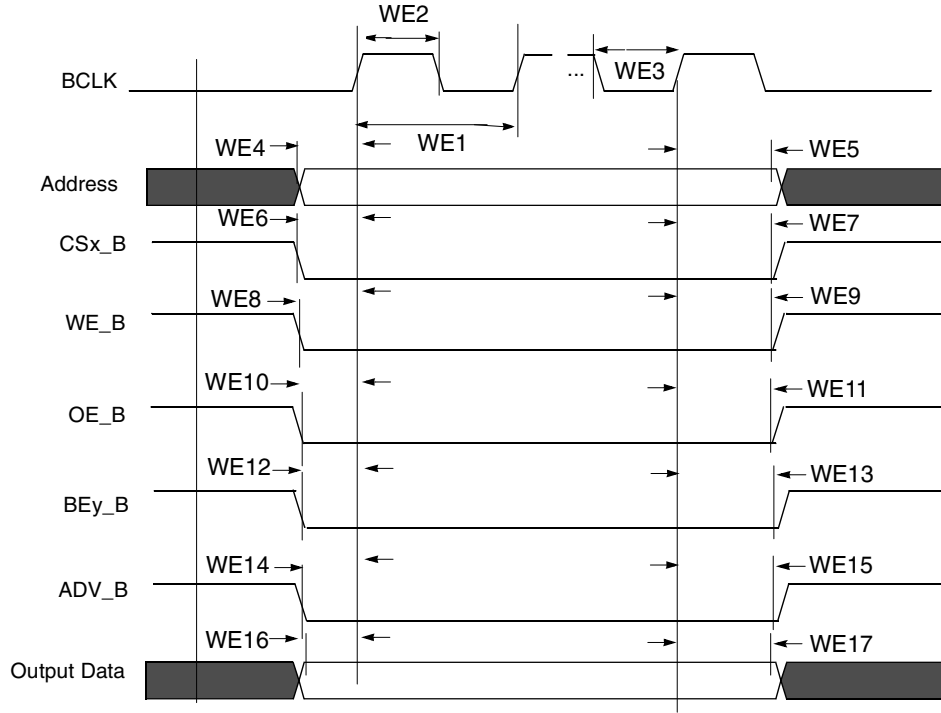

Figure 20. WEIM Outputs Timing Diagram

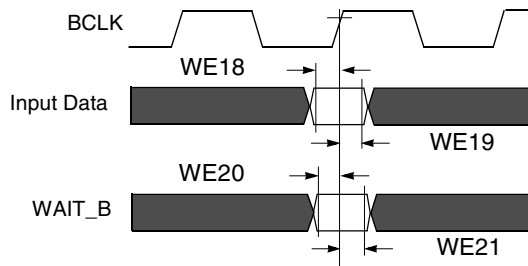

Figure 21. WEIM Inputs Timing Diagram

Table 53. WEIM Bus Timing Parameters ¹

| ID | Parameter | BCD = 0 | | BCD = 1 | | BCD = 2 | | BCD = 3 | |
|-----|------------------------------|---------|-----|---------|-----|---------|-----|---------|-----|
| | | Min | Max | Min | Max | Min | Max | Min | Max |
| WE1 | BCLK Cycle time ² | t | | 2 x t | | 3 x t | | 4 x t | |
| WE2 | BCLK Low Level Width | 0.4 x t | | 0.8 x t | | 1.2 x t | | 1.6 x t | |

Table 53. WEIM Bus Timing Parameters (continued)¹

| ID | Parameter | BCD = 0 | | BCD = 1 | | BCD = 2 | | BCD = 3 | |
|------|--|------------------------|------------------------|----------------|-------------|------------------------|------------------------|----------------------|----------------------|
| | | Min | Max | Min | Max | Min | Max | Min | Max |
| WE3 | BCLK High Level Width | $0.4 \times t$ | | $0.8 \times t$ | | $1.2 \times t$ | | $1.6 \times t$ | |
| WE4 | Clock rise to address valid ³ | $-0.5 \times t - 1.25$ | $-0.5 \times t + 1.75$ | $-t - 1.25$ | $-t + 1.75$ | $-1.5 \times t - 1.25$ | $-1.5 \times t + 1.75$ | $-2 \times t - 1.25$ | $-2 \times t + 1.75$ |
| WE5 | Clock rise to address invalid | $0.5 \times t - 1.25$ | $0.5 \times t + 1.75$ | $t - 1.25$ | $t + 1.75$ | $1.5 \times t - 1.25$ | $1.5 \times t + 1.75$ | $2 \times t - 1.25$ | $2 \times t + 1.75$ |
| WE6 | Clock rise to CSx_B valid | $-0.5 \times t - 1.25$ | $-0.5 \times t + 1.75$ | $-t - 1.25$ | $-t + 1.75$ | $-1.5 \times t - 1.25$ | $-1.5 \times t + 1.75$ | $-2 \times t - 1.25$ | $-2 \times t + 1.75$ |
| WE7 | Clock rise to CSx_B invalid | $0.5 \times t - 1.25$ | $0.5 \times t + 1.75$ | $t - 1.25$ | $t + 1.75$ | $1.5 \times t - 1.25$ | $1.5 \times t + 1.75$ | $2 \times t - 1.25$ | $2 \times t + 1.75$ |
| WE8 | Clock rise to WE_B Valid | $-0.5 \times t - 1.25$ | $-0.5 \times t + 1.75$ | $-t - 1.25$ | $-t + 1.75$ | $-1.5 \times t - 1.25$ | $-1.5 \times t + 1.75$ | $-2 \times t - 1.25$ | $-2 \times t + 1.75$ |
| WE9 | Clock rise to WE_B Invalid | $0.5 \times t - 1.25$ | $0.5 \times t + 1.75$ | $t - 1.25$ | $t + 1.75$ | $1.5 \times t - 1.25$ | $1.5 \times t + 1.75$ | $2 \times t - 1.25$ | $2 \times t + 1.75$ |
| WE10 | Clock rise to OE_B Valid | $-0.5 \times t - 1.25$ | $-0.5 \times t + 1.75$ | $-t - 1.25$ | $-t + 1.75$ | $-1.5 \times t - 1.25$ | $-1.5 \times t + 1.75$ | $-2 \times t - 1.25$ | $-2 \times t + 1.75$ |
| WE11 | Clock rise to OE_B Invalid | $0.5 \times t - 1.25$ | $0.5 \times t + 1.75$ | $t - 1.25$ | $t + 1.75$ | $1.5 \times t - 1.25$ | $1.5 \times t + 1.75$ | $2 \times t - 1.25$ | $2 \times t + 1.75$ |
| WE12 | Clock rise to BEy_B Valid | $-0.5 \times t - 1.25$ | $-0.5 \times t + 1.75$ | $-t - 1.25$ | $-t + 1.75$ | $-1.5 \times t - 1.25$ | $-1.5 \times t + 1.75$ | $-2 \times t - 1.25$ | $-2 \times t + 1.75$ |
| WE13 | Clock rise to BEy_B Invalid | $0.5 \times t - 1.25$ | $0.5 \times t + 1.75$ | $t - 1.25$ | $t + 1.75$ | $1.5 \times t - 1.25$ | $1.5 \times t + 1.75$ | $2 \times t - 1.25$ | $2 \times t + 1.75$ |
| WE14 | Clock rise to ADV_B Valid | $-0.5 \times t - 1.25$ | $-0.5 \times t + 1.75$ | $-t - 1.25$ | $-t + 1.75$ | $-1.5 \times t - 1.25$ | $-1.5 \times t + 1.75$ | $-2 \times t - 1.25$ | $-2 \times t + 1.75$ |
| WE15 | Clock rise to ADV_B Invalid | $0.5 \times t - 1.25$ | $0.5 \times t + 1.75$ | $t - 1.25$ | $t + 1.75$ | $1.5 \times t - 1.25$ | $1.5 \times t + 1.75$ | $2 \times t - 1.25$ | $2 \times t + 1.75$ |
| WE16 | Clock rise to Output Data Valid | $-0.5 \times t - 1.25$ | $-0.5 \times t + 1.75$ | $-t - 1.25$ | $-t + 1.75$ | $-1.5 \times t - 1.25$ | $-1.5 \times t + 1.75$ | $-2 \times t - 1.25$ | $-2 \times t + 1.75$ |
| WE17 | Clock rise to Output Data Invalid | $0.5 \times t - 1.25$ | $0.5 \times t + 1.75$ | $t - 1.25$ | $t + 1.75$ | $1.5 \times t - 1.25$ | $1.5 \times t + 1.75$ | $2 \times t - 1.25$ | $2 \times t + 1.75$ |
| WE18 | Input Data setup time to Clock rise | 2 ns | — | 4 ns | — | — | — | — | — |
| WE19 | Input Data hold time from Clock rise | 2 ns | — | 2 ns | — | — | — | — | — |
| WE20 | WAIT_B setup time to Clock rise | 2 ns | — | 4 ns | — | — | — | — | — |
| WE21 | WAIT_B hold time from Clock rise | 2 ns | — | 2 ns | — | — | — | — | — |

Electrical Characteristics

- ¹ t is the maximal WEIM logic (axi_clk) cycle time. The maximum allowed axi_clk frequency is 133 MHz, whereas the maximum allowed BCLK frequency is 104 MHz. As a result, if BCD = 0, axi_clk must be ≤ 104 MHz. If BCD = 1, then 133 MHz is allowed for axi_clk, resulting in a BCLK of 66.5 MHz. When the clock branch to WEIM is decreased to 104 MHz, other busses are impacted which are clocked from this source. See the CCM chapter of the i.MX51 Reference Manual for a detailed clock tree description.
- ² BCLK parameters are being measured from the 50% point, that is, high is defined as 50% of signal value and low is defined as 50% as signal value.
- ³ For signal measurements “High” is defined as 80% of signal value and “Low” is defined as 20% of signal value.

4.6.7.4 Examples of WEIM Synchronous Accesses

Figure 22 to Figure 25 provide few examples of basic WEIM accesses to external memory devices with the timing parameters mentioned previously for specific control parameters settings.

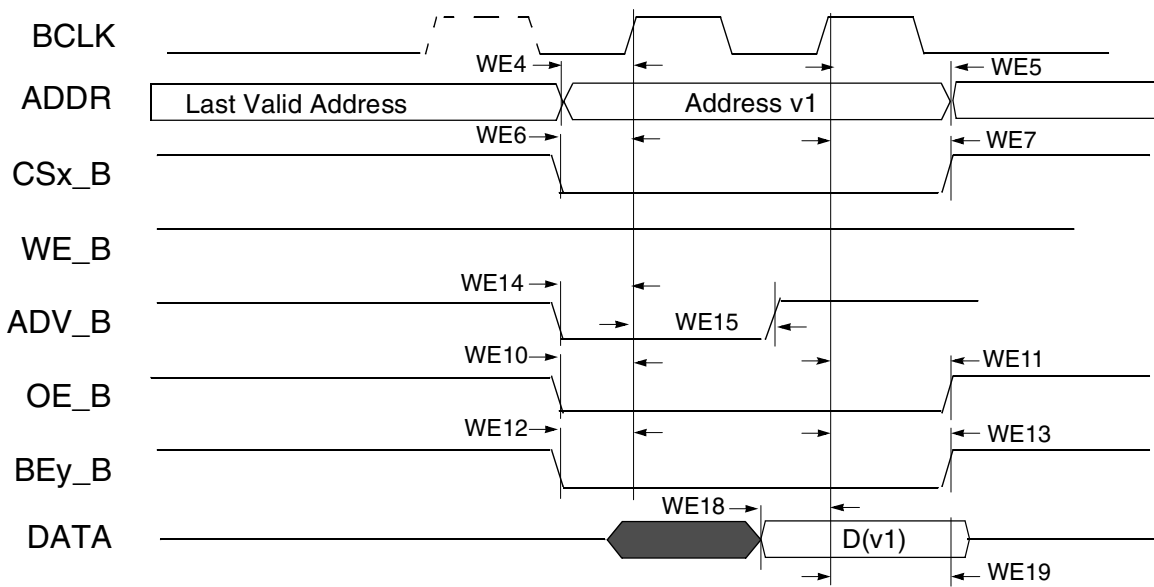

Figure 22. Synchronous Memory Read Access, WSC=1

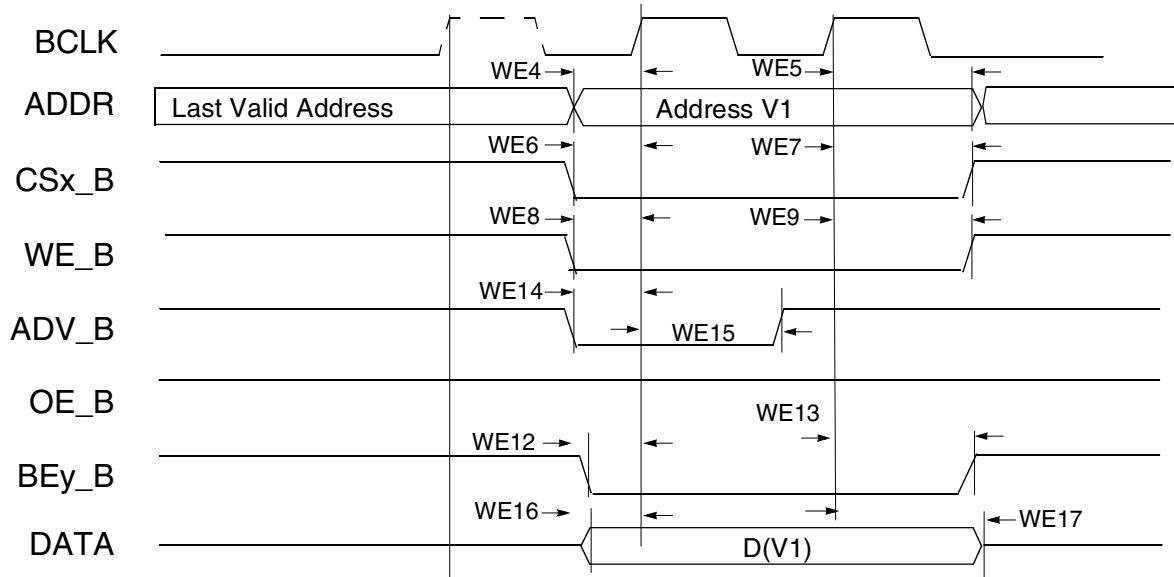

Figure 23. Synchronous Memory, Write Access, WSC=1, WBEA=0, and WADVN=0

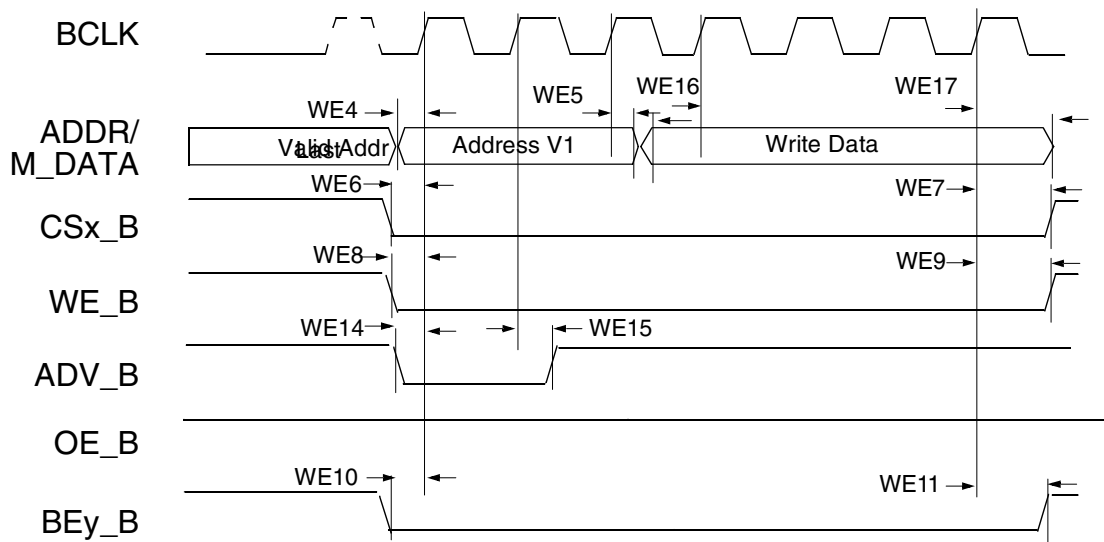

Figure 24. Muxed Address/Data (A/D) Mode, Synchronous Write Access, WSC=6, ADVA=0, ADVN=1, and ADH=1

NOTE

In 32-bit muxed address/data (A/D) mode the 16 MSBs are driven on the data bus.

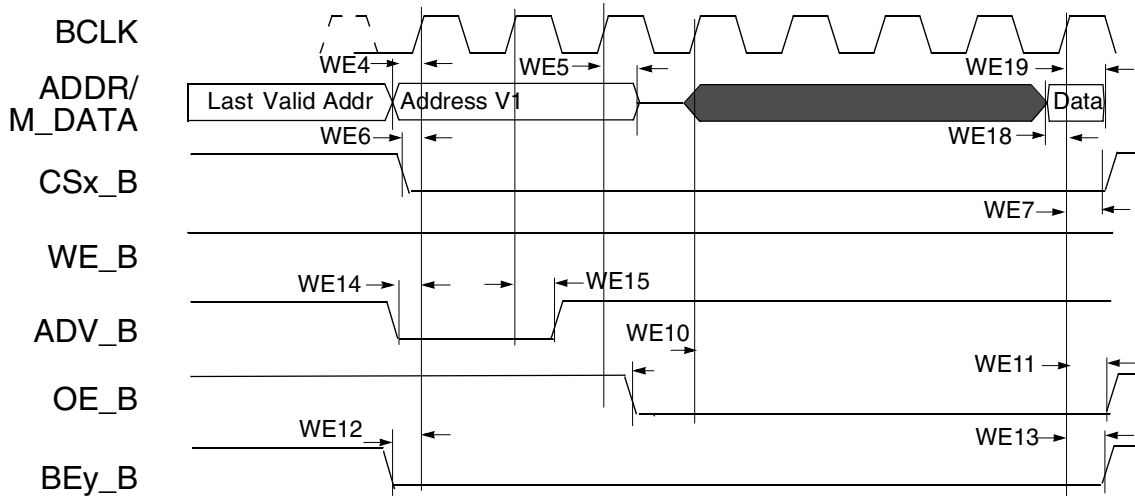

Figure 25. 16-Bit Muxed A/D Mode, Synchronous Read Access, WSC=7, RADVN=1, ADH=1, and OEA=0

4.6.7.5 General WEIM Timing-Asynchronous Mode

Figure 26 through Figure 31, and Table 54 help to determine timing parameters relative to the chip select (CS) state for asynchronous and DTACK WEIM accesses with corresponding WEIM bit fields and the timing parameters mentioned above.

Asynchronous read and write access length in cycles may vary from what is shown in Figure 26 through Figure 29 as RWSC, OEN, and CSN is configured differently. See i.MX51 reference manual for the WEIM programming model.

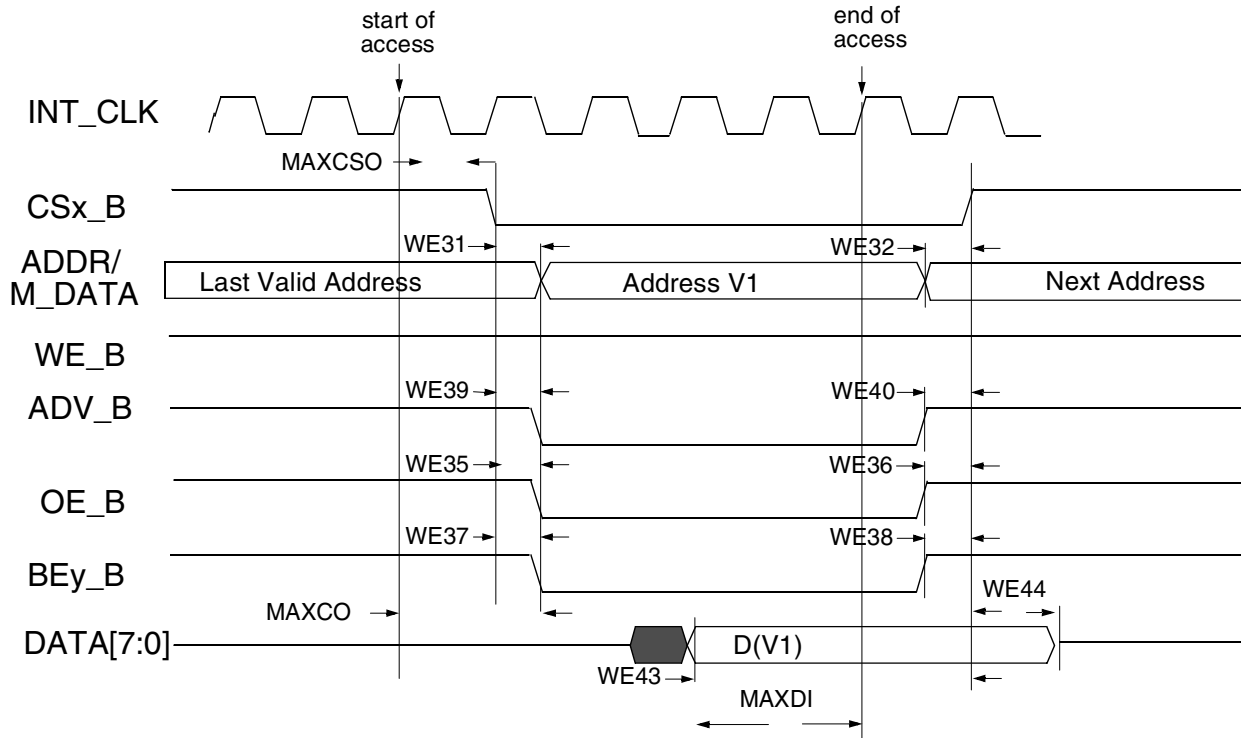

Figure 26. Asynchronous Memory Read Access (RWSC = 5)

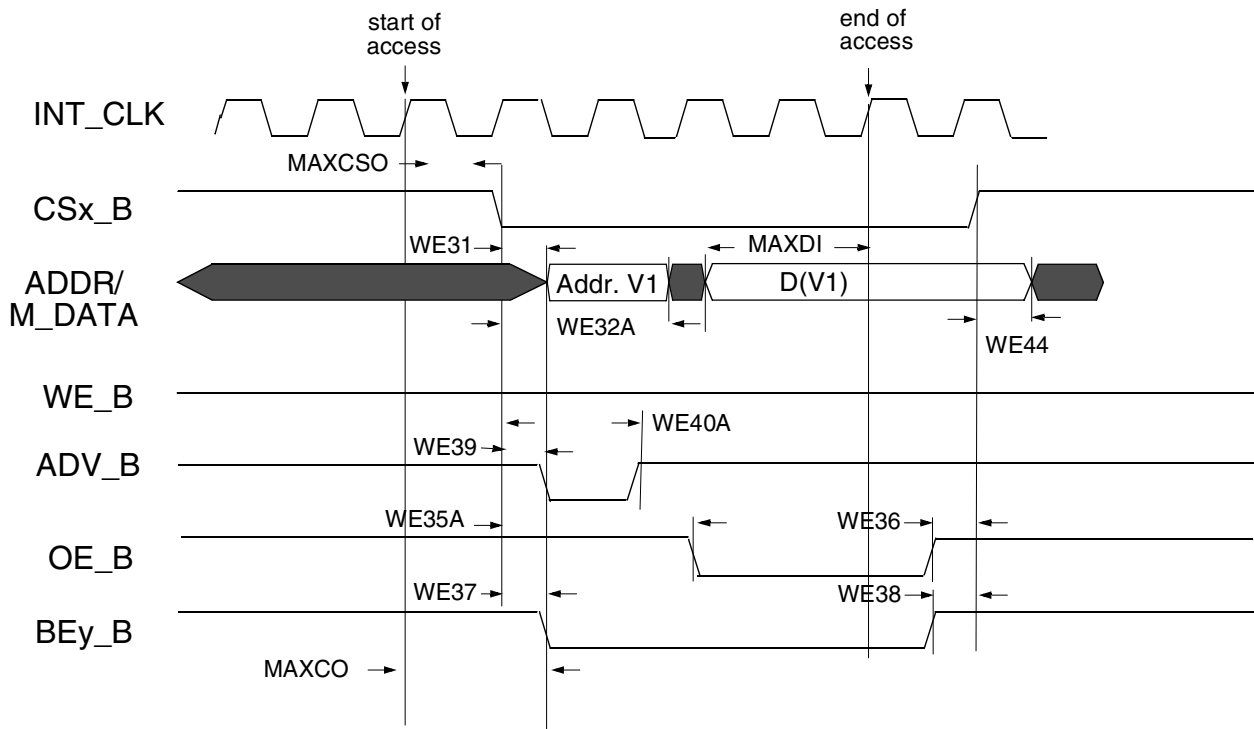

Figure 27. Asynchronous A/D Muxed Read Access (RWSC = 5)

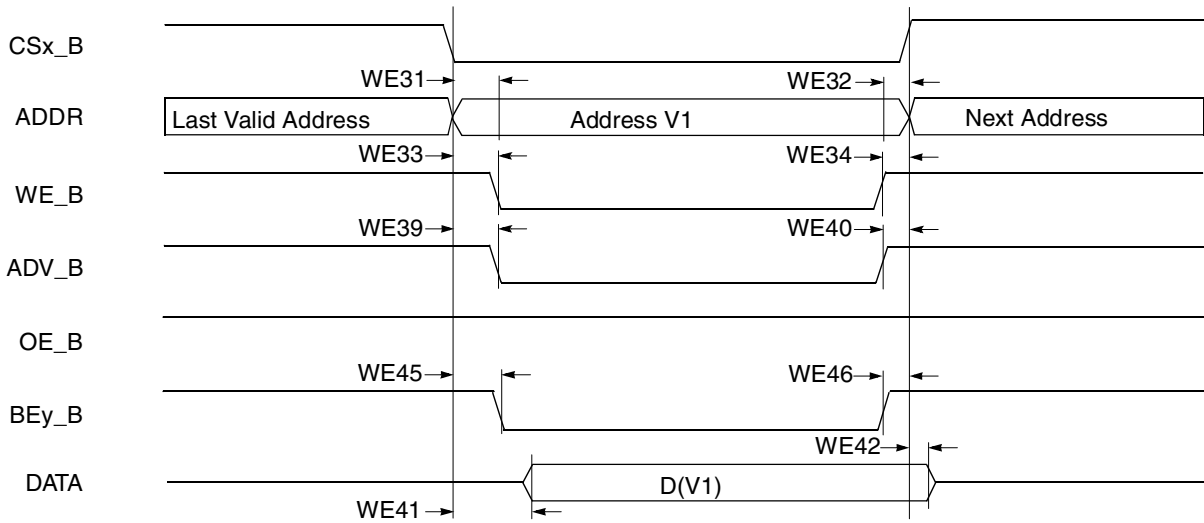

Figure 28. Asynchronous Memory Write Access

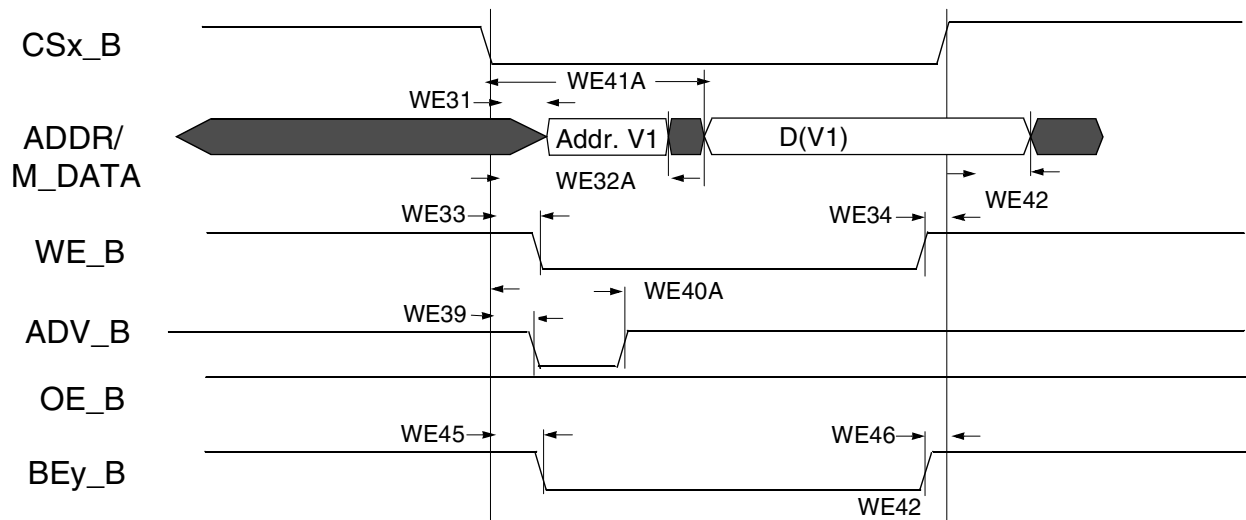

Figure 29. Asynchronous A/D Muxed Write Access

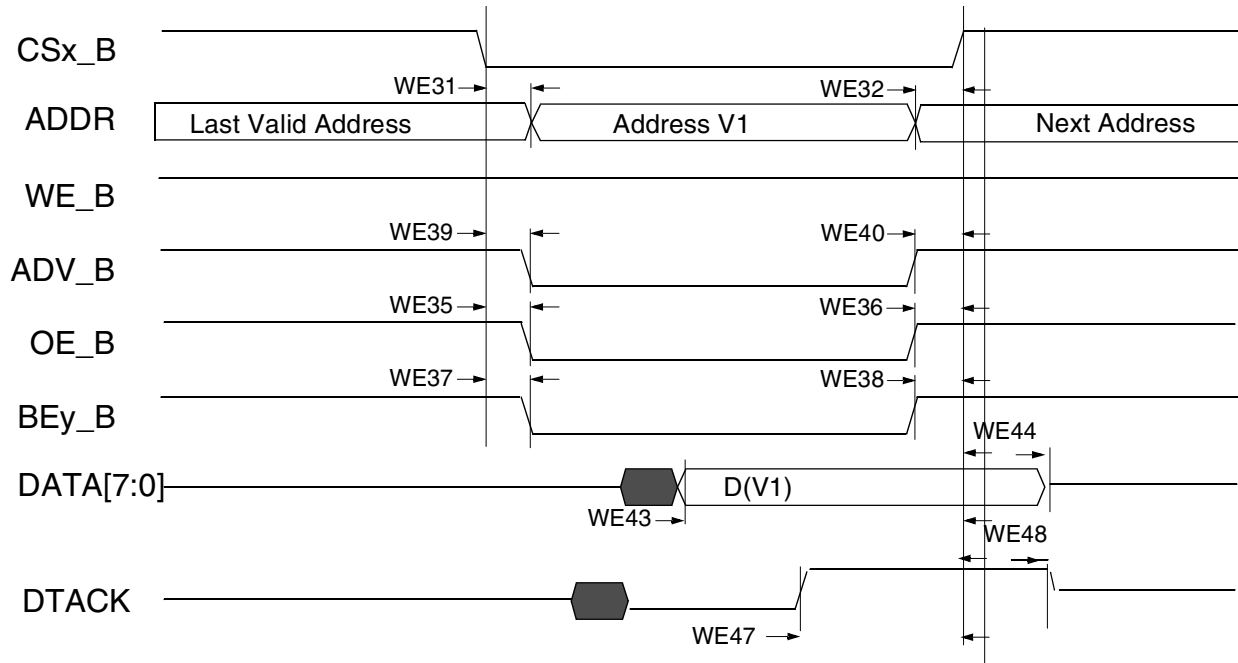

Figure 30. DTACK Read Access (DAP=0)

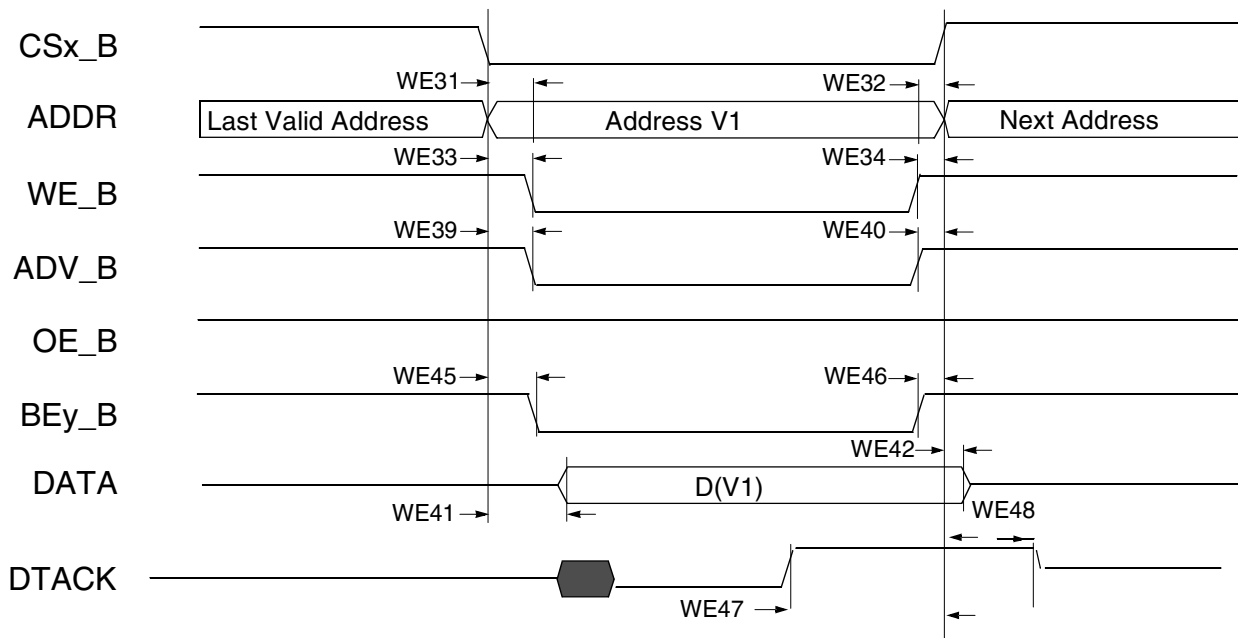

Figure 31. DTACK Write Access (DAP=0)

Electrical Characteristics

Table 54. WEIM Asynchronous Timing Parameters Table Relative Chip Select

| Ref No. | Parameter | Determination by Synchronous measured parameters ¹² | Min | Max (If 133 MHz is supported by SOC) | Unit |
|------------------|---|--|------------------------------------|---------------------------------------|------|
| WE31 | CSx_B valid to Address Valid | WE4 - WE6 - CSA ³ | — | 3 - CSA | ns |
| WE32 | Address Invalid to CSx_B invalid | WE7 - WE5 - CSN ⁴ | — | 3 - CSN | ns |
| WE32A(muxed A/D) | CSx_B valid to Address Invalid | t ⁵ + WE4 - WE7 + (ADVN + ADVA + 1 - CSA ³) | -3 + (ADVN + ADVA + 1 - CSA) | — | ns |
| WE33 | CSx_B Valid to WE_B Valid | WE8 - WE6 + (WEA - CSA) | — | 3 + (WEA - CSA) | ns |
| WE34 | WE_B Invalid to CSx_B Invalid | WE7 - WE9 + (WEN - CSN) | — | 3 - (WEN - CSN) | ns |
| WE35 | CSx_B Valid to OE_B Valid | WE10 - WE6 + (OEA - CSA) | — | 3 + (OEA - CSA) | ns |
| WE35A(muxed A/D) | CSx_B Valid to OE_B Valid | WE10 - WE6 + (OEA + RADVN + RADVA + ADH + 1 - CSA) | -3 + (OEA + RADVN+RADVA+ADH+1-CSA) | 3 + (OEA + RADVN+RADVA+ADH+1-CSA) | ns |
| WE36 | OE_B Invalid to CSx_B Invalid | WE7 - WE11 + (OEN - CSN) | — | 3 - (OEN - CSN) | ns |
| WE37 | CSx_B Valid to BEy_B Valid (Read access) | WE12 - WE6 + (RBEA - CSA) | — | 3 + (RBEA ⁶ - CSA) | ns |
| WE38 | BEy_B Invalid to CSx_B Invalid (Read access) | WE7 - WE13 + (RBEN - CSN) | — | 3 - (RBEN ⁷ - CSN) | ns |
| WE39 | CSx_B Valid to ADV_B Valid | WE14 - WE6 + (ADVA - CSA) | — | 3 + (ADVA - CSA) | ns |
| WE40 | ADV_B Invalid to CSx_B Invalid (ADVL is asserted) | WE7 - WE15 - CSN | — | 3 - CSN | ns |
| WE40A(muxed A/D) | CSx_B Valid to ADV_B Invalid | WE14 - WE6 + (ADVN + ADVA + 1 - CSA) | -3 + (ADVN + ADVA + 1 - CSA) | 3 + (ADVN + ADVA + 1 - CSA) | ns |
| WE41 | CSx_B Valid to Output Data Valid | WE16 - WE6 - WCSA | — | 3 - WCSA | ns |
| WE41A(muxed A/D) | CSx_B Valid to Output Data Valid | WE16 - WE6 + (WADV N + WADVA + ADH + 1 - WCSA) | — | 3 + (WADV N + WADVA + ADH + 1 - WCSA) | ns |
| WE42 | Output Data Invalid to CSx_B Invalid | WE17 - WE7 - CSN | — | 3 - CSN | ns |
| MAXCO | Output max. delay from internal driving ADDR/control FFs to chip outputs. | 10 | — | — | ns |
| MAXCS O | Output max. delay from CSx internal driving FFs to CSx out. | 10 | — | — | |
| MAXDI | DATA MAXIMUM delay from chip input data to its internal FF | 5 | — | — | |

Table 54. WEIM Asynchronous Timing Parameters Table Relative Chip Select

| Ref No. | Parameter | Determination by Synchronous measured parameters ¹² | Min | Max (If 133 MHz is supported by SOC) | Unit |
|---------|---|--|---------------------------|--------------------------------------|------|
| WE43 | Input Data Valid to CSx_B Invalid | $MAXCO - MAXCSO + MAXDI$ | $MAXCO - MAXCSO + MAXDI$ | — | ns |
| WE44 | CSx_B Invalid to Input Data invalid | 0 | 0 | — | ns |
| WE45 | CSx_B Valid to BEy_B Valid (Write access) | $WE12 - WE6 + (WBEA - CSA)$ | — | $3 + (WBEA - CSA)$ | ns |
| WE46 | BEy_B Invalid to CSx_B Invalid (Write access) | $WE7 - WE13 + (WBEN - CSN)$ | — | $-3 + (WBEN - CSN)$ | ns |
| MAXDTI | DTACK MAXIMUM delay from chip dtack input to its internal FF + 2 cycles for synchronization | | — | — | — |
| WE47 | Dtack Active to CSx_B Invalid | $MAXCO - MAXCSO + MAXDTI$ | $MAXCO - MAXCSO + MAXDTI$ | — | ns |
| WE48 | CSx_B Invalid to Dtack invalid | 0 | 0 | — | ns |

¹ Parameters WE4... WE21 value see column BCD = 0 in Table 53.

² All config. parameters (CSA,CSN,WBEA,WBEN,ADVA,ADVN,OEN,OEA,RBEA & RBEN) are in cycle units.

³ CS Assertion. This bit field determines when CS signal is asserted during read/write cycles.

⁴ CS Negation. This bit field determines when CS signal is negated during read/write cycles.

⁵ t is axi_clk cycle time.

⁶ BE Assertion. This bit field determines when BE signal is asserted during read cycles.

⁷ BE Negation. This bit field determines when BE signal is negated during read cycles.

4.6.8 SDRAM Controller Timing Parameters

4.6.8.1 Mobile DDR SDRAM Timing Parameters

Figure 32 shows the basic timing parameters for mobile DDR (mDDR) SDRAM. The timing parameters for this diagram is shown in Table 55.

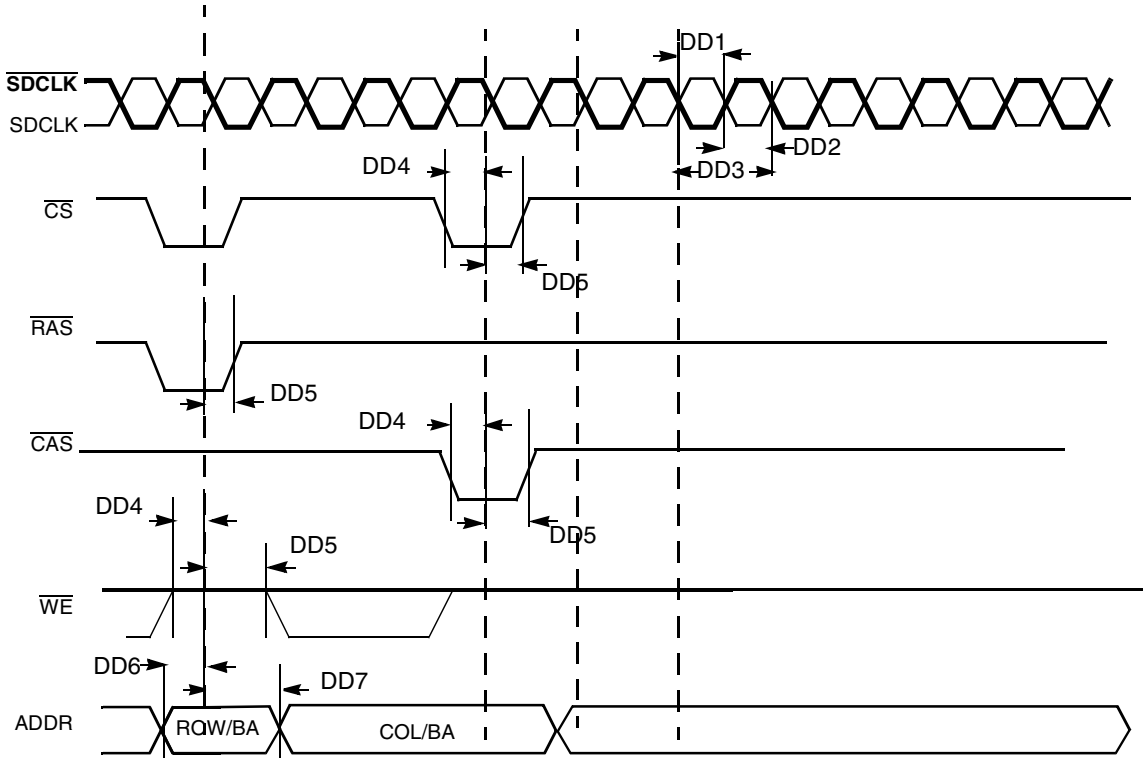

Figure 32. mDDR SDRAM Basic Timing Parameters

Table 55. mDDR SDRAM Timing Parameter Table

| ID | Parameter | Symbol | 200 MHz | | 166 MHz | | 133 MHz | | Unit |
|-----|----------------------------------|------------------------------|---------|------|---------|------|---------|------|-----------------|
| | | | Min | Max | Min | Max | Min | Max | |
| DD1 | SDRAM clock high-level width | t _{CH} | 0.45 | 0.55 | 0.45 | 0.55 | 0.45 | 0.55 | t _{CK} |
| DD2 | SDRAM clock low-level width | t _{CL} | 0.45 | 0.55 | 0.45 | 0.55 | 0.45 | 0.55 | t _{CK} |
| DD3 | SDRAM clock cycle time | t _{CK} | 5 | — | 6 | — | 7.5 | — | ns |
| DD4 | CS, RAS, CAS, CKE, WE setup time | t _{IS} ¹ | 0.9 | — | 1.1 | — | 1.3 | — | ns |
| DD5 | CS, RAS, CAS, CKE, WE hold time | t _{IH} ¹ | 0.9 | — | 1.1 | — | 1.3 | — | ns |
| DD6 | Address output setup time | t _{IS} ¹ | 0.9 | — | 1.1 | — | 1.3 | — | ns |
| DD7 | Address output hold time | t _{IH} ¹ | 0.9 | — | 1.1 | — | 1.3 | — | ns |

¹ This parameter is affected by pad timing. if the slew rate is < 1 V/ns, 0.2 ns should be added to the value. For cmos65 pads this is true for medium and low drive strengths.

Figure 33 shows the timing diagram for mDDR SDRAM write cycle. The timing parameters for this diagram is shown in Table 56.

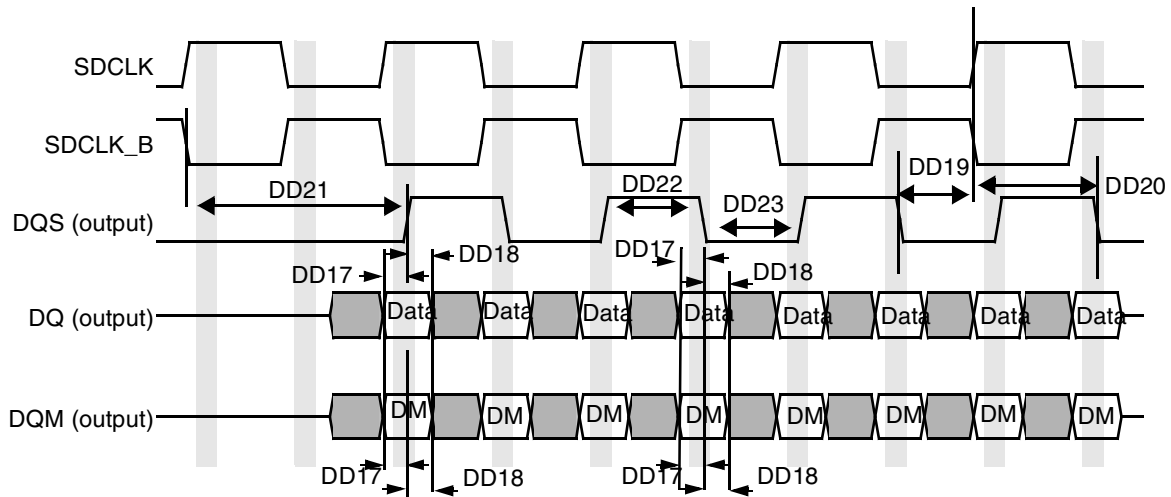

Figure 33. mDDR SDRAM Write cycle Timing Diagram

Table 56. mDDR SDRAM Write Cycle Parameter Table¹

| ID | Parameter | Symbol | 200 MHz ² | | 166 MHz | | 133 MHz | | Unit |
|------|---|------------------------------|----------------------|------|---------|------|---------|------|------|
| | | | Min | Max | Min | Max | Min | Max | |
| DD17 | DQ and DQM setup time to DQS | t _{DS} ³ | 0.48 | — | 0.6 | — | 0.8 | — | ns |
| DD18 | DQ and DQM hold time to DQS | t _{DH} ¹ | 0.48 | — | 0.6 | — | 0.8 | — | ns |
| DD19 | Write cycle DQS falling edge to SDCLK output setup time | t _{DSS} | 0.2 | — | 0.2 | — | 0.2 | — | tCK |
| DD20 | Write cycle DQS falling edge to SDCLK output hold time | t _{DSH} | 0.2 | — | 0.2 | — | 0.2 | — | tCK |
| DD21 | Write command to first DQS latching transition | t _{DQSS} | 0.75 | 1.25 | 0.75 | 1.25 | 0.75 | 1.25 | tCK |
| DD22 | DQS high level width | t _{DQSH} | 0.4 | 0.6 | 0.4 | 0.6 | 0.4 | 0.6 | tCK |
| DD23 | DQS low level width | t _{DQSL} | 0.4 | 0.6 | 0.4 | 0.6 | 0.4 | 0.6 | tCK |

¹ Test conditions are: Capacitance 15 pF for DDR PADS. Recommended drive strengths is medium for SDCLK and high for address and controls.

² SDRAM CLK and DQS related parameters are being measured from the 50% point. that is, high is defined as 50% of signal value and low is defined as 50% as signal value. DDR SDRAM CLK parameters are measured at the crossing point of SDCLK and $\overline{\text{SDCLK}}$ (inverted clock).

³ This parameter is affected by pad timing. If the slew rate is < 1 V/ns, 0.1 ns should be increased to this value.

Electrical Characteristics

Figure 34 shows the timing diagram for mDDR SDRAM DQ versus DQS and SDCLK read cycle. The timing parameters for this diagram is shown in Table 57.

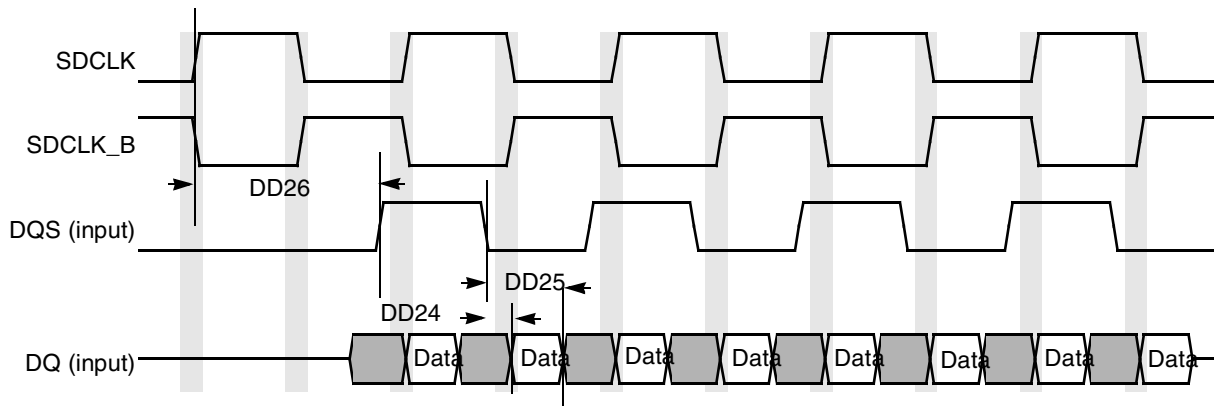

Figure 34. mDDR SDRAM DQ vs. DQS and SDCLK READ Cycle Timing Diagram

Table 57. mDDR SDRAM Read Cycle Parameter Table¹

| ID | PARAMETER | Symbol | 200 MHz ² | | 166 MHz | | 133 MHz | | Unit |
|------|---|--------------------|----------------------|-----|---------|------|---------|------|------|
| | | | Min | Max | Min | Max | Min | Max | |
| DD24 | DQS - DQ Skew (defines the Data valid window in read cycles related to DQS) | t _{DQSQ} | — | 0.4 | — | 0.75 | — | 0.85 | ns |
| DD25 | DQS DQ in HOLD time from DQS | t _{QH} | 1.75 | — | 2.05 | — | 2.6 | — | ns |
| DD26 | DQS output access time from SDCLK posedge | t _{DQSCK} | 2 | 5 | 2 | 5.5 | 2 | 6.5 | ns |

¹ Test conditions are: Capacitance 15 pF for DDR PADS. Recommended drive strengths is medium for SDCLK and high for address and controls

² SDRAM CLK and DQS related parameters are being measured from the 50% point. that is, high is defined as 50% of signal value and low is defined as 50% as signal value. DDR SDRAM CLK parameters are measured at the crossing point of SDCLK and $\overline{\text{SDCLK}}$ (inverted clock)

4.6.9 DDR2 SDRAM Specific Parameters

Figure 35 shows the timing parameters for DDR2. The timing parameters for this diagram appear in Table 58.

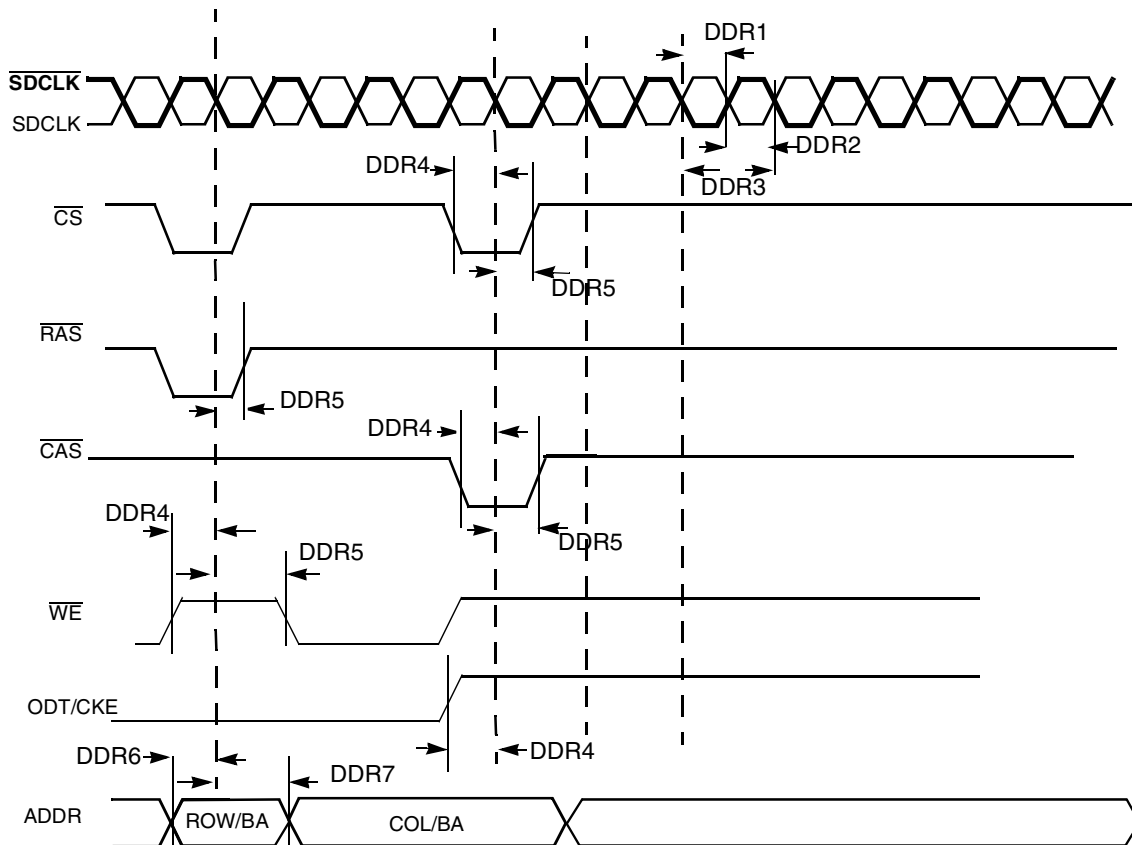

Figure 35. DDR2 SDRAM Basic Timing Parameters

Table 58. DDR2 SDRAM Timing Parameter Table

| ID | Parameter | Symbol | SDCLK = 200 MHz | | Unit |
|------|---------------------------------------|------------------------------|-----------------|------|-----------------|
| | | | Min | Max | |
| DDR1 | SDRAM clock high-level width | t _{CH} | 0.45 | 0.55 | t _{CK} |
| DDR2 | SDRAM clock low-level width | t _{CL} | 0.45 | 0.55 | t _{CK} |
| DDR3 | SDRAM clock cycle time | t _{CK} | 5 | — | ns |
| DDR4 | CS, RAS, CAS, CKE, WE, ODT setup time | t _{IS} ¹ | 1.5 | — | ns |
| DDR5 | CS, RAS, CAS, CKE, WE, ODT hold time | t _{IH} ¹ | 1.7 | — | ns |

Table 58. DDR2 SDRAM Timing Parameter Table (continued)

| ID | Parameter | Symbol | SDCLK = 200 MHz | | Unit |
|------|---------------------------|------------|-----------------|-----|------|
| | | | Min | Max | |
| DDR6 | Address output setup time | t_{IS}^1 | 1.7 | — | ns |
| DDR7 | Address output hold time | t_{IH}^1 | 1.5 | — | ns |

¹ These values are for command/address slew rates of 1 V/ns and SDCLK / SDCLK_B differential slew rate of 2 V/ns. For different values use the settings shown in [Table 59](#).

NOTE

Measurements are taken from Vref to Vref (cross-point to cross-point), but JEDEC timings for single-ended signals are defined from Vref to Vil(ac) max or to Vih(ac) min.

Table 59. Derating Values for DDR2-400 (SDCLK = 200 MHz)

| Command / Address Slew Rate (V/ns) | SDCLK Differential Slew Rates ^{1,2} | | | | | | Unit |
|------------------------------------|--|-----------------|-----------------|-----------------|-----------------|-----------------|------|
| | 2.0 V/ns | | 1.5 V/ns | | 1.0 V/ns | | |
| | Δt_{IS} | Δt_{IH} | Δt_{IS} | Δt_{IH} | Δt_{IS} | Δt_{IH} | |
| 4.0 | +187 | +94 | +217 | +124 | +247 | +154 | ps |
| 3.5 | +179 | +89 | +209 | +119 | +239 | +149 | ps |
| 3.0 | +167 | +83 | +197 | +113 | +227 | +143 | ps |
| 2.5 | +150 | +75 | +180 | +105 | +210 | +135 | ps |
| 2.0 | +125 | +45 | +155 | +75 | +185 | +105 | ps |
| 1.5 | +83 | +21 | +113 | +51 | +143 | +81 | ps |
| 1.0 | +0 | +0 | +30 | +30 | +60 | +60 | ps |
| 0.9 | -11 | -14 | +19 | +16 | +49 | +46 | ps |
| 0.8 | -25 | -31 | +5 | -1 | +35 | +29 | ps |
| 0.7 | -43 | -54 | -13 | -24 | +17 | +6 | ps |
| 0.6 | -67 | -83 | -37 | -53 | -7 | -23 | ps |
| 0.5 | -110 | -125 | -80 | -95 | -50 | -65 | ps |
| 0.4 | -175 | -188 | -145 | -158 | -115 | -128 | ps |
| 0.3 | -285 | -292 | -255 | -262 | -225 | -232 | ps |
| 0.25 | -350 | -375 | -320 | -345 | -290 | -315 | ps |
| 0.2 | -525 | -500 | -495 | -470 | -465 | -440 | ps |
| 0.15 | -800 | -708 | -770 | -678 | -740 | -648 | ps |
| 0.1 | -1450 | -1125 | -1420 | -1095 | -1390 | -1065 | ps |

- ¹ Test conditions are: Capacitance 15 pF for DDR contacts. Recommended drive strengths: Medium for SDCLK and High for address and controls.
- ² SDCLK and DQS related parameters are measured from the 50% point. For example, a high is defined as 50% of the signal value and a low is defined as 50% of the signal value. DDR SDRAM CLK parameters are measured at the crossing point of SDCLK and SDCLK_B.

Figure 36 shows the timing diagram for DDR2 SDRAM write cycle. The timing parameters for this diagram appear in Table 60.

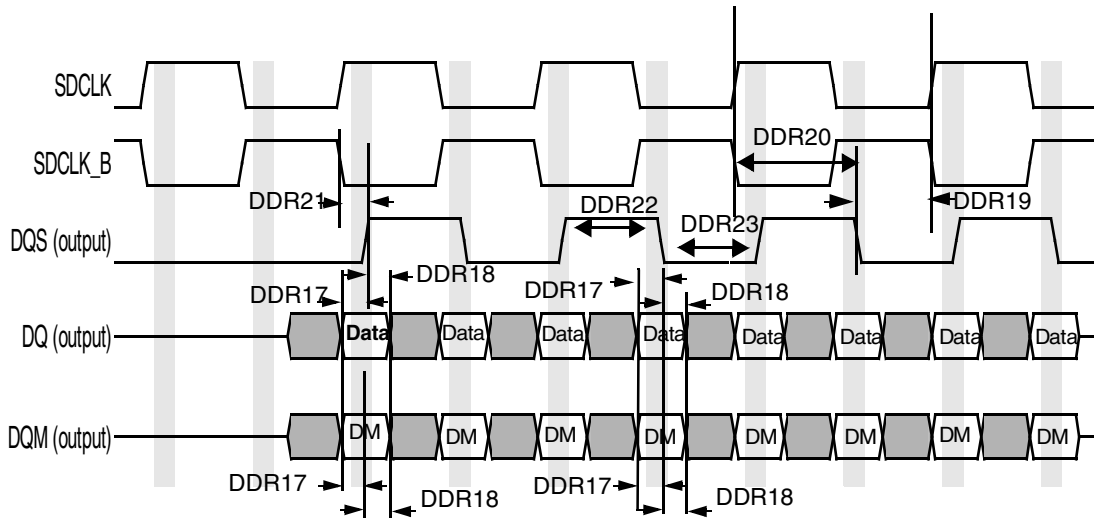

Figure 36. DDR2 SDRAM Write Cycle Timing Diagram

Table 60. DDR2 SDRAM Write Cycle Parameter Table

| ID | Parameter | Symbol | SDCLK = 200 MHz | | Unit |
|-------|---|--------|------------------|-----|------|
| | | | Min | Max | |
| DDR17 | DQ & DQM setup time to DQS | tDS | 0.8 ¹ | — | ns |
| DDR18 | DQ & DQM hold time to DQS | tDH | 0.8 ² | — | ns |
| DDR19 | DQS falling edge to SDCLK output setup time | tDSS | 1.6 | — | ns |
| DDR20 | DQS falling edge SDCLK output hold time | tDSH | 2.4 | — | ns |
| DDR21 | DQS latching rising transitions to associated clock edges | tDQSS | -0.7 | 0.3 | ns |
| DDR22 | DQS high level width | tDQSH | 0.35 | — | tCK |
| DDR23 | DQS low level width | tDQSL | 0.35 | — | tCK |

¹ - In order to meet these setup/hold values, write calibration should be performed to place the DQS in the middle of DQ window. The minimum window width is 1.6ns (DDR17+DDR18).

- From DDR controller perspective, the timing is the same for both differential and single ended mode.

² - In order to meet these setup/hold values, write calibration should be performed to place the DQS in the middle of DQ window. The minimum window width is 1.6ns (DDR17+DDR18).

- From DDR controller perspective, the timing is the same for both differential and single ended mode.

NOTE

Measurements are taken from Vref to Vref (cross-point to cross-point), but JEDEC timings for single-ended signals are defined from Vref to Vil(ac) max or to Vih(ac) min.

Table 61. Derating values for DDR2 Differential DQS^{1,2}

| $\Delta tDS, \Delta tDH$ derating values for DDR2-400, DDR2-533 (All units in 'ps'; the note applies to the entire table) | | | | | | | | | | | | | | | | | | | |
|---|-----|---------------|---------------|---------------|---------------|---------------|---------------|---------------|---------------|---------------|---------------|---------------|---------------|---------------|---------------|---------------|---------------|---------------|---------------|
| DQS, \overline{DQS} Differential Slew Rate | | | | | | | | | | | | | | | | | | | |
| | | 4.0 V/ns | | 3.0 V/ns | | 2.0 V/ns | | 1.8 V/ns | | 1.6 V/ns | | 1.4 V/ns | | 1.2 V/ns | | 1.0 V/ns | | 0.8 V/ns | |
| | | ΔtD_S | ΔtD_H | ΔtD_S | ΔtD_H | ΔtD_S | ΔtD_H | ΔtD_S | ΔtD_H | ΔtD_S | ΔtD_H | ΔtD_S | ΔtD_H | ΔtD_S | ΔtD_H | ΔtD_S | ΔtD_H | ΔtD_S | ΔtD_H |
| DQ Slew rate V/ns | 2.0 | 125 | 45 | 125 | 45 | 125 | 45 | - | - | - | - | - | - | - | - | - | - | - | - |
| | 1.5 | 83 | 21 | 83 | 21 | 83 | 21 | 95 | 33 | - | - | - | - | - | - | - | - | - | - |
| | 1.0 | 0 | 0 | 0 | 0 | 0 | 0 | 12 | 12 | 24 | 24 | - | - | - | - | - | - | - | - |
| | 0.9 | - | - | -11 | -14 | -11 | -14 | 1 | -2 | 13 | 10 | 25 | 22 | - | - | - | - | - | - |
| | 0.8 | - | - | - | - | -25 | -31 | -13 | -19 | -1 | -7 | 11 | 5 | 23 | 17 | - | - | - | - |
| | 0.7 | - | - | - | - | - | - | -31 | -42 | -19 | -30 | -7 | -18 | 5 | -6 | 17 | 6 | - | - |
| | 0.6 | - | - | - | - | - | - | - | - | -43 | -59 | -31 | -47 | -19 | -35 | -7 | -23 | 5 | -11 |
| | 0.5 | - | - | - | - | - | - | - | - | - | - | -74 | -89 | -62 | -77 | -50 | -65 | -38 | -53 |
| | 0.4 | - | - | - | - | - | - | - | - | - | - | - | - | -127 | -140 | -115 | -128 | -103 | -116 |

Table 62. Derating values for DDR2 Single Ended DQS^{3,4}

| $\Delta tDS1, \Delta tDH1$ derating values for DDR2-400, DDR2-533 (All units in 'ps'; the note applies to the entire table) | | | | | | | | | | | | | | | | | | | |
|---|-----|------------------|------------------|------------------|------------------|------------------|------------------|------------------|------------------|------------------|------------------|------------------|------------------|------------------|------------------|------------------|------------------|------------------|------------------|
| DQS Single-ended Slew Rate | | | | | | | | | | | | | | | | | | | |
| | | 2.0 V/ns | | 1.5 V/ns | | 1.0 V/ns | | 0.9 V/ns | | 0.8 V/ns | | 0.7 V/ns | | 0.6 V/ns | | 0.5 V/ns | | 0.4 V/ns | |
| | | ΔtD_{S1} | ΔtD_{H1} | ΔtD_{S1} | ΔtD_{H1} | ΔtD_{S1} | ΔtD_{H1} | ΔtD_{S1} | ΔtD_{H1} | ΔtD_{S1} | ΔtD_{H1} | ΔtD_{S1} | ΔtD_{H1} | ΔtD_{S1} | ΔtD_{H1} | ΔtD_{S1} | ΔtD_{H1} | ΔtD_{S1} | ΔtD_{H1} |
| DQ Slew rate V/ns | 2.0 | 188 | 188 | 167 | 146 | 125 | 63 | - | - | - | - | - | - | - | - | - | - | - | - |
| | 1.5 | 146 | 167 | 125 | 125 | 83 | 42 | 81 | 43 | - | - | - | - | - | - | - | - | - | - |
| | 1.0 | 63 | 125 | 42 | 83 | 0 | 0 | -2 | 1 | -7 | -13 | - | - | - | - | - | - | - | - |
| | 0.9 | - | - | 31 | 69 | -11 | -14 | -13 | -13 | -18 | -27 | -29 | -45 | - | - | - | - | - | - |
| | 0.8 | - | - | - | - | -25 | -31 | -27 | -30 | -32 | -44 | -43 | -62 | -60 | -86 | - | - | - | - |
| | 0.7 | - | - | - | - | - | - | -45 | -53 | -50 | -67 | -61 | -85 | -78 | -109 | -108 | -152 | - | - |
| | 0.6 | - | - | - | - | - | - | - | - | -74 | -96 | -85 | -114 | -102 | -138 | -132 | -181 | -183 | -246 |
| | 0.5 | - | - | - | - | - | - | - | - | - | - | -128 | -156 | -145 | -180 | -175 | -223 | -226 | -288 |
| | 0.4 | - | - | - | - | - | - | - | - | - | - | - | - | -210 | -243 | -240 | -286 | -291 | -351 |

1. Test conditions are: Capacitance 15 pF for DDR PADS. Recommended drive strengths is medium for SDCLK and high for address and controls.
2. SDRAM CLK and DQS related parameters are being measured from the 50% point. that is, high is defined as 50% of signal value and low is defined as 50% as signal value. DDR SDRAM CLK parameters are measured at the crossing point of SDCLK and \overline{SDCLK} (inverted clock).
3. Test conditions are: Capacitance 15 pF for DDR PADS. Recommended drive strengths is medium for SDCLK and high for address and controls.
4. SDRAM CLK and DQS related parameters are being measured from the 50% point. that is, high is defined as 50% of signal value and low is defined as 50% as signal value. DDR SDRAM CLK parameters are measured at the crossing point of SDCLK and \overline{SDCLK} (inverted clock).

Figure 37 shows the timing diagram for DDR2 SDRAM read cycle. The timing parameters for this diagram appear in Table 63.

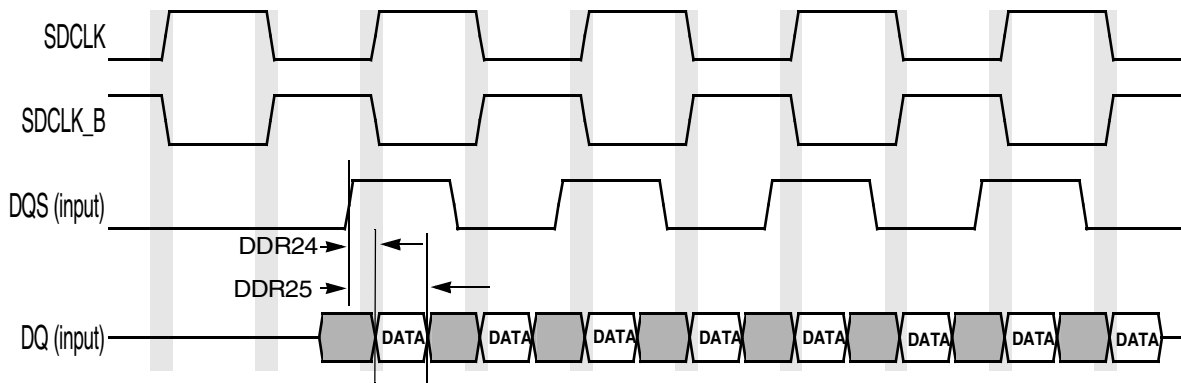

Figure 37. DDR2 SDRAM DQ versus DQS and SDCLK Read Cycle Timing Diagram

Table 63. DDR2 SDRAM Read Cycle Parameter Table

| ID | Parameter | Symbol | SDCLK = 200 MHz | | Unit |
|--------------------|--|--------|-----------------|-----|------|
| | | | Min | Max | |
| DDR24 ¹ | DQS—DQ Skew (defines the Data valid window during read cycles related to DQS). | tDQSQ | — | 0.5 | ns |
| DDR25 ² | DQ HOLD time from DQS | tQH | 1.8 | — | ns |

¹ The actual timing may vary depending on read calibration settings. What is actually important for the controller is DDR25-DDR24 which results in the minimum required DQ valid window width: 1.8ns-0.5ns = 1.3ns of minimum width.

² The actual timing may vary depending on read calibration settings. What is actually important for the controller is DDR25-DDR24 which results in the minimum required DQ valid window width: 1.8ns-0.5ns = 1.3ns of minimum width.

NOTE

It is recommended to perform read calibration process in order to achieve the best performance.

4.7 External Peripheral Interfaces

The following sections provide information on external peripheral interfaces.

4.7.1 CSPI Timing Parameters

This section describes the timing parameters of the CSPI. The CSPI has separate timing parameters for master and slave modes. The nomenclature used with the CSPI modules and the respective routing of these signals is shown in [Table 64](#).

Table 64. CSPI Nomenclature and Routing

| Module | I/O Access |
|--------|---|
| eCSPI1 | CSPI1 ¹ , USBH1, and DI1 via IOMUX |
| eCSPI2 | NANDF and USBH1 via IOMUX |
| CSPI | NANDF, USBH1, SD1, SD2, and GPIO via IOMUX |

¹ This set of BGA contacts is labeled CSPI, but is actually an eCSPI channel

4.7.1.1 CSPI Master Mode Timing

[Figure 38](#) depicts the timing of CSPI in Master mode and [Table 65](#) lists the CSPI Master Mode timing characteristics.

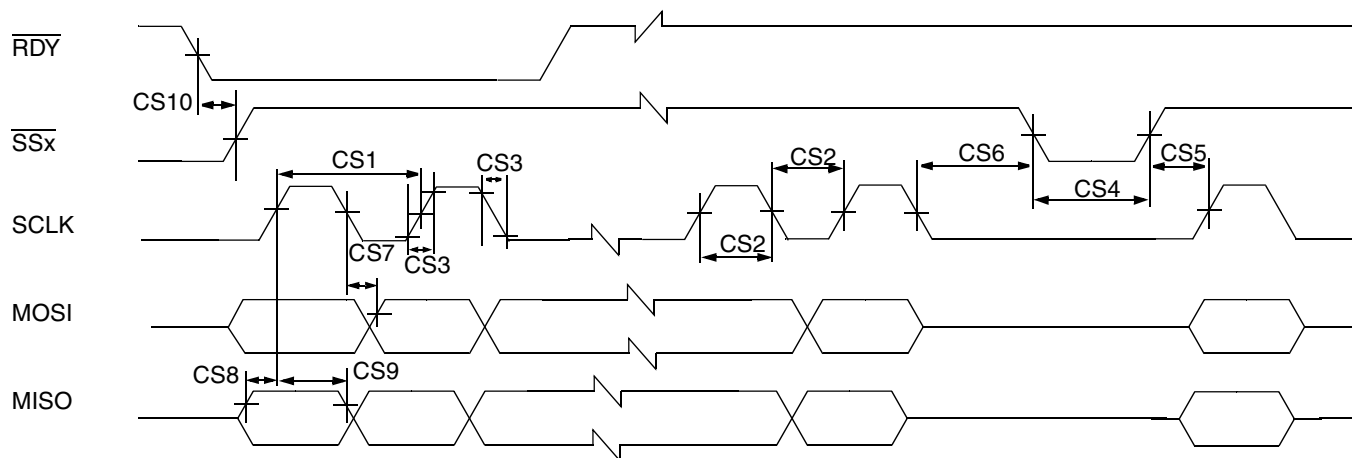

Figure 38. CSPI Master Mode Timing Diagram

Table 65. CSPI Master Mode Timing Parameters

| ID | Parameter | Symbol | Min | Max | Unit |
|-----|--------------------------------|-----------------|-----|-----|------|
| CS1 | SCLK Cycle Time | t_{clk} | 60 | — | ns |
| CS2 | SCLK High or Low Time | t_{sw} | 26 | — | ns |
| CS3 | SCLK Rise or Fall ¹ | $t_{RISE/FALL}$ | — | — | ns |
| CS4 | SSx pulse width | t_{CSLH} | 26 | — | ns |

Table 65. CSPI Master Mode Timing Parameters (continued)

| ID | Parameter | Symbol | Min | Max | Unit |
|------|--|--------------|-----|-----|------|
| CS5 | SSx Lead Time (Slave Select setup time) | t_{SCS} | 26 | — | ns |
| CS6 | SSx Lag Time (SS hold time) | t_{HCS} | 26 | — | ns |
| CS7 | MOSI Propagation Delay ($C_{LOAD} = 20$ pF) | t_{PDmosi} | -1 | 21 | ns |
| CS8 | MISO Setup Time | t_{Smiso} | 5 | — | ns |
| CS9 | MISO Hold Time | t_{Hmiso} | 5 | — | ns |
| CS10 | RDY to SSx Time ² | t_{SDRY} | 5 | — | ns |

¹ See specific I/O AC parameters Section 4.5, "I/O AC Parameters"

² SPI_RDY is sampled internally by ipg_clk and is asynchronous to all other CSPI signals.

4.7.1.2 CSPI Slave Mode Timing

Figure 39 depicts the timing of CSPI in Slave mode. Table 66 lists the CSPI Slave Mode timing characteristics.

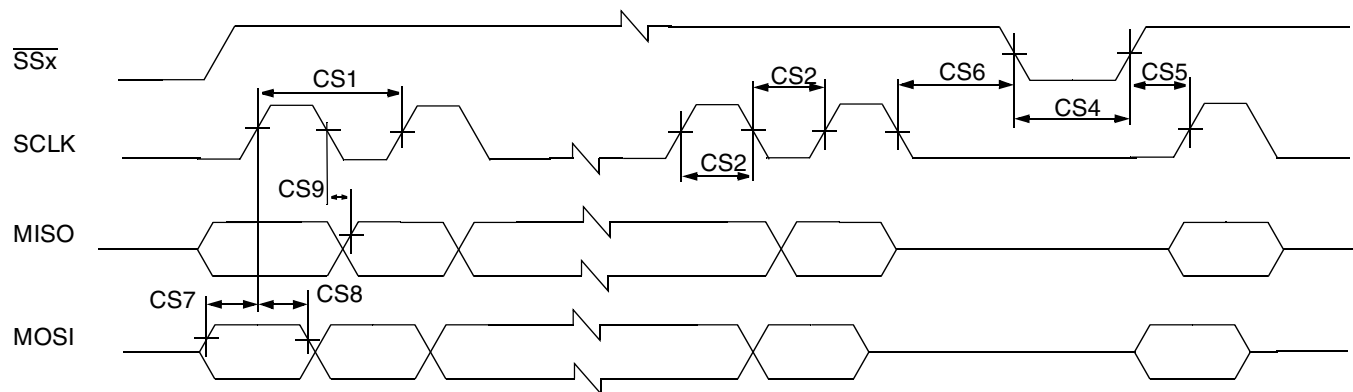

Figure 39. CSPI Slave Mode Timing Diagram

Table 66. CSPI Slave Mode Timing Parameters

| ID | Parameter | Symbol | Min | Max | Unit |
|-----|-------------------------------|-------------|-----|-----|------|
| CS1 | SCLK Cycle Time | t_{clk} | 60 | — | ns |
| CS2 | SCLK High or Low Time | t_{SW} | 26 | — | ns |
| CS4 | SSx pulse width | t_{CSLH} | 26 | — | ns |
| CS5 | SSx Lead Time (SS setup time) | t_{SCS} | 26 | — | ns |
| CS6 | SSx Lag Time (SS hold time) | t_{HCS} | 26 | — | ns |
| CS7 | MOSI Setup Time | t_{Smosi} | 5 | — | ns |

Table 66. CSPI Slave Mode Timing Parameters (continued)

| ID | Parameter | Symbol | Min | Max | Unit |
|-----|--|--------------|-----|-----|------|
| CS8 | MOSI Hold Time | t_{Hmosi} | 5 | — | ns |
| CS9 | MISO Propagation Delay ($C_{LOAD} = 20\text{ pF}$) | t_{PDmiso} | 0 | 35 | ns |

4.7.2 eCSPI Timing Parameters

This section describes the timing parameters of the eCSPI. The eCSPI has separate timing parameters for master and slave modes. The nomenclature used with the CSPI modules and the respective routing of these signals is shown in Table 64.

4.7.2.1 eCSPI Master Mode Timing

Figure 40 depicts the timing of eCSPI in Master mode and Table 67 lists the eCSPI Master Mode timing characteristics.

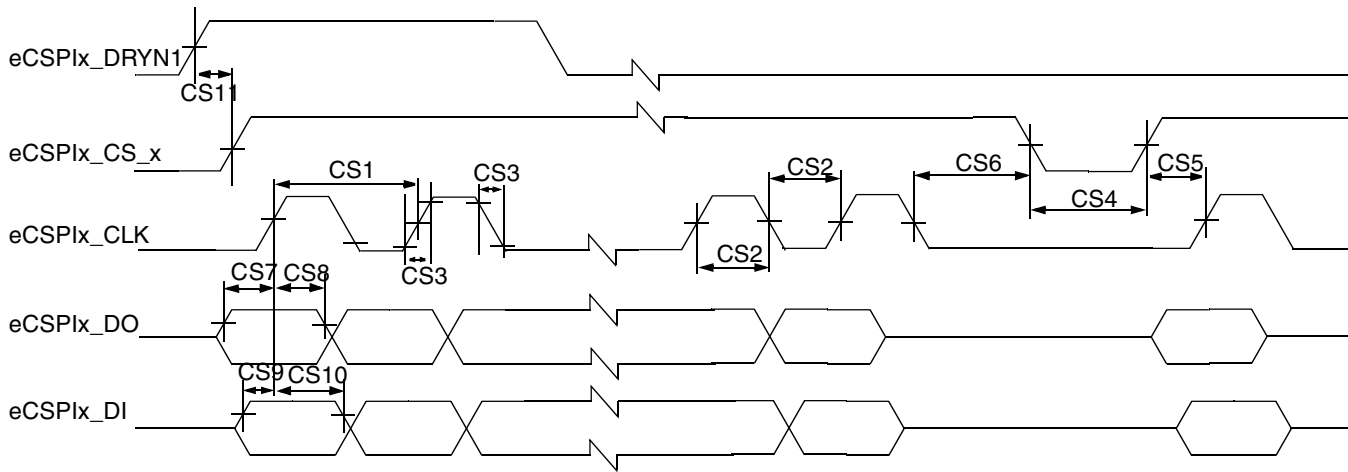

Figure 40. eCSPI Master Mode Timing Diagram

Table 67. eCSPI Master Mode Timing Parameters

| ID | Parameter | Symbol | Min | Max | Unit |
|-----|---|-----------------|----------|-----|------|
| CS1 | eCSPIx_CLK Cycle Time—Read eCSPIx_CLK Cycle Time—Write | t_{clk} | 60 15 | — | ns |
| CS2 | eCSPIx_CLK High or Low Time | t_{SW} | 6 | — | ns |
| CS3 | eCSPIx_CLK Rise or Fall | $t_{RISE/FALL}$ | — | — | ns |
| CS4 | eCSPIx_CS_x pulse width | t_{CSLH} | 15 | — | ns |
| CS5 | eCSPIx_CS_x Lead Time (CS setup time) | t_{SCS} | 5 | — | ns |
| CS6 | eCSPIx_CS_x Lag Time (CS hold time) | t_{HCS} | 5 | — | ns |
| CS7 | eCSPIx_DO Setup Time | t_{Smosi} | 5 | — | ns |

Table 67. eCSPI Master Mode Timing Parameters (continued)

| ID | Parameter | Symbol | Min | Max | Unit |
|------|------------------------|-------------|-----|-----|------|
| CS8 | eCSPIx_DO Hold Time | t_{Hmosi} | 5 | — | ns |
| CS9 | eCSPIx_DI Setup Time | t_{Smiso} | 5 | — | ns |
| CS10 | eCSPIx_DI Hold Time | t_{Hmiso} | 5 | — | ns |
| CS11 | eCSPIx_DRYN Setup Time | t_{SDRY} | 5 | — | ns |

4.7.2.2 eCSPI Slave Mode Timing

Figure 41 depicts the timing of eCSPI in Slave mode and Table 68 lists the eCSPI Slave Mode timing characteristics.

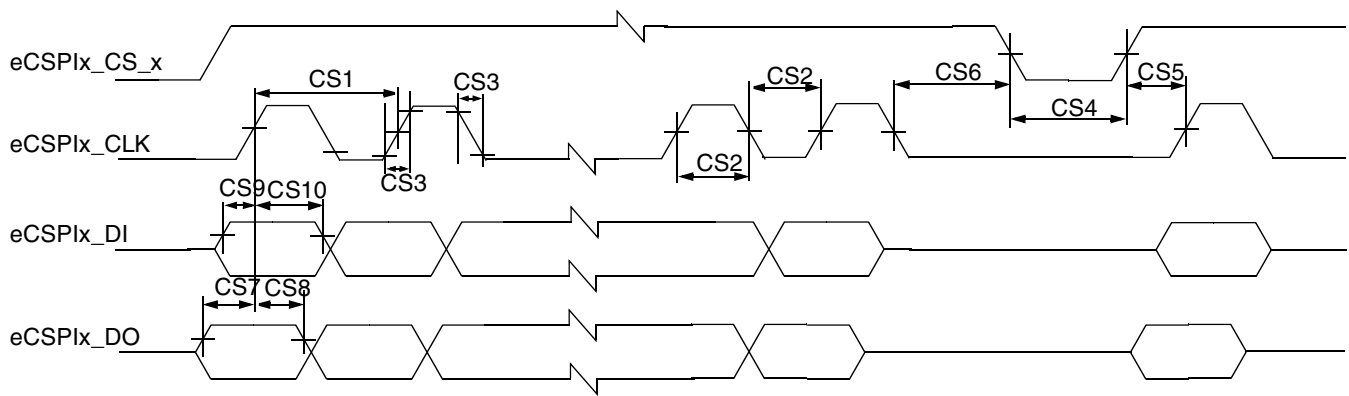

Figure 41. eCSPI Slave Mode Timing Diagram

Table 68. eCSPI Slave Mode Timing Parameters

| ID | Parameter | Symbol | Min | Max | Unit |
|------|---|-----------------|----------|-----|------|
| CS1 | eCSPIx_CLK Cycle Time—Read eCSPIx_CLK Cycle Time—Write | t_{clk} | 60 15 | — | ns |
| CS2 | eCSPIx_CLK High or Low Time | t_{sw} | 6 | — | ns |
| CS3 | eCSPIx_CLK Rise or Fall | $t_{RISE/FALL}$ | — | — | ns |
| CS4 | eCSPIx_CS_x pulse width | t_{CSLH} | 15 | — | ns |
| CS5 | eCSPIx_CS_x Lead Time (CS setup time) | t_{SCS} | 5 | — | ns |
| CS6 | eCSPIx_CS_x Lag Time (CS hold time) | t_{HCS} | 5 | — | ns |
| CS7 | eCSPIx_DO Setup Time | t_{Smosi} | 5 | — | ns |
| CS8 | eCSPIx_DO Hold Time | t_{Hmosi} | 5 | — | ns |
| CS9 | eCSPIx_DI Setup Time | t_{Smiso} | 5 | — | ns |
| CS10 | eCSPIx_DI Hold Time | t_{Hmiso} | 5 | — | ns |

4.7.3 eSDHCv2 Timing Parameters

This section describes the electrical information of the eSDHCv2.

Figure 42 depicts the timing of eSDHCv2, and Table 69 lists the eSDHCv2 timing characteristics.

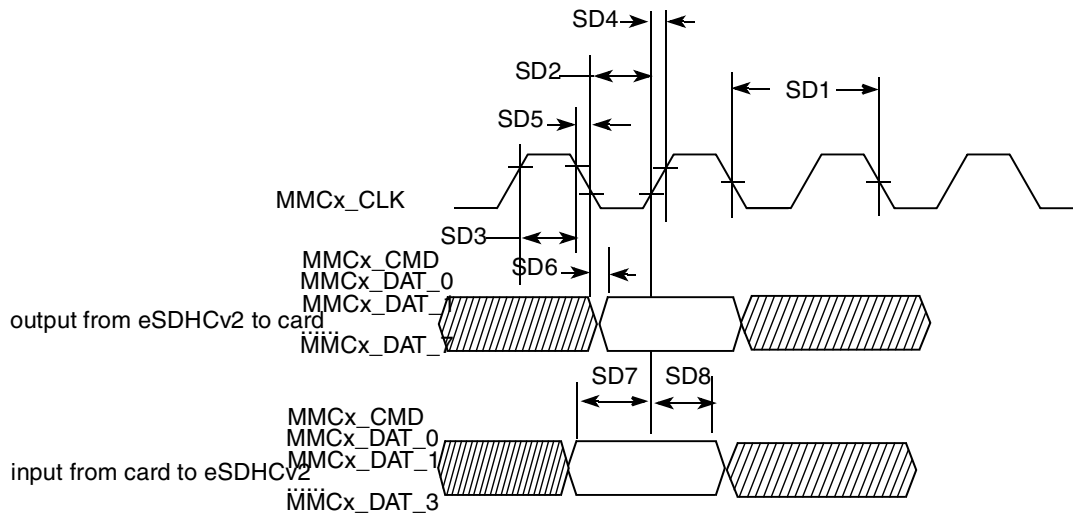

Figure 42. eSDHCv2 Timing

Table 69. eSDHCv2 Interface Timing Specification

| ID | Parameter | Symbols | Min | Max | Unit |
|---|---|------------|-----|-------|------|
| Card Input Clock | | | | | |
| SD1 | Clock Frequency (Low Speed) | f_{PP}^1 | 0 | 400 | kHz |
| | Clock Frequency (SD/SDIO Full Speed/High Speed) | f_{PP}^2 | 0 | 25/50 | MHz |
| | Clock Frequency (MMC Full Speed/High Speed) | f_{PP}^3 | 0 | 20/52 | MHz |
| | Clock Frequency (Identification Mode) | f_{OD} | 100 | 400 | kHz |
| SD2 | Clock Low Time | t_{WL} | 7 | — | ns |
| SD3 | Clock High Time | t_{WH} | 7 | — | ns |
| SD4 | Clock Rise Time | t_{TLH} | — | 3 | ns |
| SD5 | Clock Fall Time | t_{THL} | — | 3 | ns |
| eSDHC Output/Card Inputs CMD, DAT (Reference to CLK) | | | | | |
| SD6 ⁴ | eSDHC Output Delay | t_{OD} | -3 | 3 | ns |
| eSDHC Input / Card Outputs CMD, DAT (Reference to CLK) | | | | | |

Table 69. eSDHCv2 Interface Timing Specification (continued)

| ID | Parameter | Symbols | Min | Max | Unit |
|-----|------------------------|------------|-----|-----|------|
| SD7 | eSDHC Input Setup Time | t_{ISU} | 2.5 | — | ns |
| SD8 | eSDHC Input Hold Time | t_{IH}^5 | 2.5 | — | ns |

¹ In low speed mode, card clock must be lower than 400 kHz, voltage ranges from 2.7 to 3.6 V.

² In normal speed mode for SD/SDIO card, clock frequency can be any value between 0–25 MHz. In high-speed mode, clock frequency can be any value between 0–50 MHz.

³ In normal speed mode for MMC card, clock frequency can be any value between 0–20 MHz. In high-speed mode, clock frequency can be any value between 0–52 MHz.

⁴ Measurement taken with CLoad = 20 pF

⁵ To satisfy hold timing, the delay difference between clock input and cmd/data input must not exceed 2 ns.

4.7.4 FEC AC Timing Parameters

This section describes the electrical information of the Fast Ethernet Controller (FEC) module. The FEC is designed to support both 10 and 100 Mbps Ethernet/IEEE 802.3 networks. An external transceiver interface and transceiver function are required to complete the interface to the media. The FEC supports the 10/100 Mbps MII (18 pins in total) and the 10 Mbps-only 7-wire interface, which uses 7 of the MII pins, for connection to an external Ethernet transceiver. For the pin list of MII and 7-wire, see i.MX51 Multimedia Applications Processor Reference Manual (MCIMX51RM).

This section describes the AC timing specifications of the FEC.

4.7.4.1 MII Receive Signal Timing

The MII receive signal timing involves the FEC_RXD[3:0], FEC_RX_DV, FEC_RX_ER, and FEC_RX_CLK signals. The receiver functions correctly up to a FEC_RX_CLK maximum frequency of 25 MHz + 1%. There is no minimum frequency requirement but the processor clock frequency must exceed twice the FEC_RX_CLK frequency. Table 70 lists the MII receive channel signal timing parameters and Figure 43 shows MII receive signal timings.

Table 70. MII Receive Signal Timing

| Num | Characteristic ¹ | Min | Max | Unit |
|-----|--|-----|-----|-------------------|
| M1 | FEC_RXD[3:0], FEC_RX_DV, FEC_RX_ER to FEC_RX_CLK setup | 5 | — | ns |
| M2 | FEC_RX_CLK to FEC_RXD[3:0], FEC_RX_DV, FEC_RX_ER hold | 5 | — | ns |
| M3 | FEC_RX_CLK pulse width high | 35% | 65% | FEC_RX_CLK period |
| M4 | FEC_RX_CLK pulse width low | 35% | 65% | FEC_RX_CLK period |

¹ FEC_RX_DV, FEC_RX_CLK, and FEC_RXD0 have same timing in 10 Mbps 7-wire interface mode.

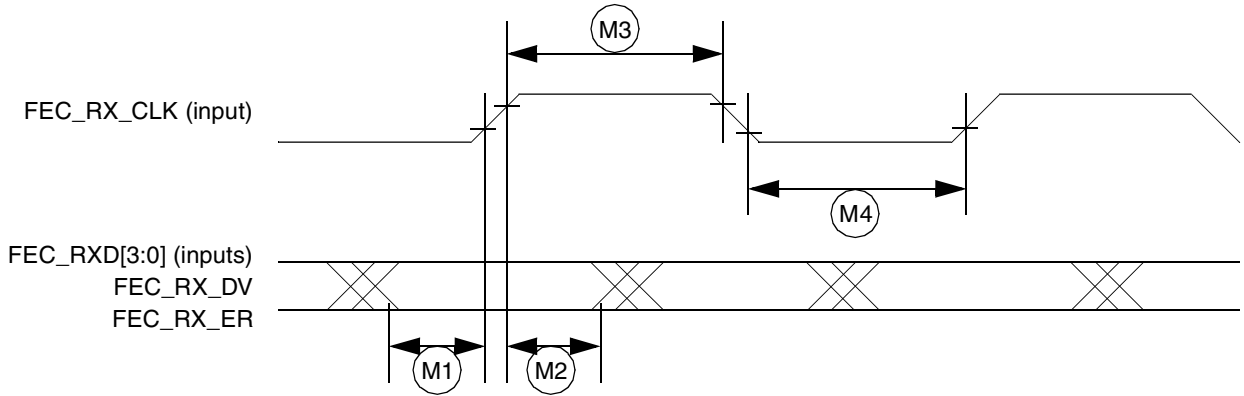

Figure 43. MII Receive Signal Timing Diagram

4.7.4.2 MII Transmit Signal Timing

The MII transmit signal timing affects the FEC_TXD[3:0], FEC_TX_EN, FEC_TX_ER, and FEC_TX_CLK signals. The transmitter functions correctly up to a FEC_TX_CLK maximum frequency of 25 MHz + 1%. There is no minimum frequency requirement. In addition, the processor clock frequency must exceed twice the FEC_TX_CLK frequency. Table 71 lists MII transmit channel timing parameters and Figure 44 shows MII transmit signal timing diagram for the values listed in Table 71.

Table 71. MII Transmit Signal Timing

| Num | Characteristic ¹ | Min | Max | Unit |
|-----|--|-----|-----|-------------------|
| M5 | FEC_TX_CLK to FEC_TXD[3:0], FEC_TX_EN, FEC_TX_ER invalid | 5 | — | ns |
| M6 | FEC_TX_CLK to FEC_TXD[3:0], FEC_TX_EN, FEC_TX_ER valid | — | 20 | ns |
| M7 | FEC_TX_CLK pulse width high | 35% | 65% | FEC_TX_CLK period |
| M8 | FEC_TX_CLK pulse width low | 35% | 65% | FEC_TX_CLK period |

¹ FEC_TX_EN, FEC_TX_CLK, and FEC_TXD0 have the same timing in 10 Mbps 7-wire interface mode.

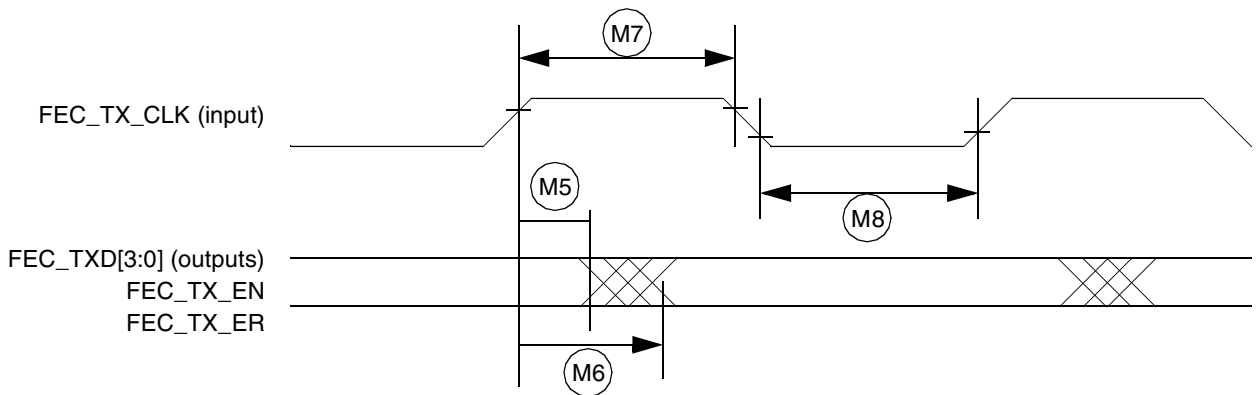

Figure 44. MII Transmit Signal Timing Diagram

4.7.4.3 MII Async Inputs Signal Timing (FEC_CRIS and FEC_COL)

Table 72 lists MII asynchronous inputs signal timing information. Figure 45 shows MII asynchronous input timings listed in Table 72.

Table 72. MII Async Inputs Signal Timing

| Num | Characteristic | Min | Max | Unit |
|-----------------|---|-----|-----|-------------------|
| M9 ¹ | FEC_CRIS to FEC_COL minimum pulse width | 1.5 | — | FEC_TX_CLK period |

¹ FEC_COL has the same timing in 10 Mbit 7-wire interface mode.

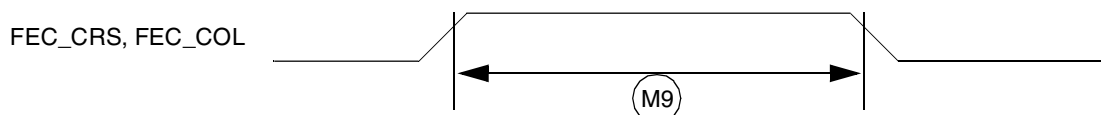

Figure 45. MII Async Inputs Timing Diagram

4.7.4.4 MII Serial Management Channel Timing (FEC_MDIO and FEC_MDC)

Table 73 lists MII serial management channel timings. Figure 46 shows MII serial management channel timings listed in Table 73. The MDC frequency should be equal to or less than 2.5 MHz to be compliant with the IEEE 802.3 MII specification. However the FEC can function correctly with a maximum MDC frequency of 15 MHz.

Table 73. MII Transmit Signal Timing

| ID | Characteristic | Min | Max | Unit |
|-----|---|-----|-----|----------------|
| M10 | FEC_MDC falling edge to FEC_MDIO output invalid (minimum propagation delay) | 0 | — | ns |
| M11 | FEC_MDC falling edge to FEC_MDIO output valid (max propagation delay) | — | 5 | ns |
| M12 | FEC_MDIO (input) to FEC_MDC rising edge setup | 18 | — | ns |
| M13 | FEC_MDIO (input) to FEC_MDC rising edge hold | 0 | — | ns |
| M14 | FEC_MDC pulse width high | 40% | 60% | FEC_MDC period |
| M15 | FEC_MDC pulse width low | 40% | 60% | FEC_MDC period |

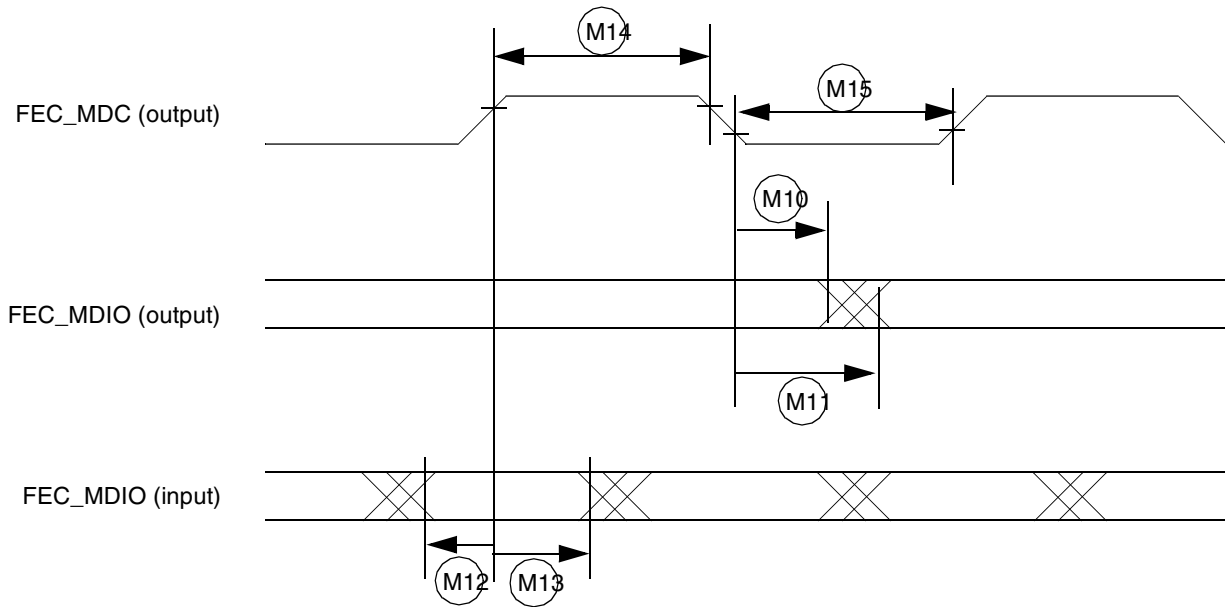

Figure 46. MII Serial Management Channel Timing Diagram

4.7.5 Frequency Pre-Multiplier (FPM) Electrical Parameters (CKIL)

The FPM is a DPLL that converts a signal operating in the kilohertz region into a clock signal operating in the megahertz region. The output of the FPM provides the reference frequency for the on-chip DPLLs. Parameters of the FPM are listed in Table 74.

Table 74. FPM Specifications

| Parameter | Min | Typ | Max | Unit |
|--|-----|--------|-------|------|
| Reference clock frequency range—CKIL | 32 | 32.768 | 256 | kHz |
| FPM output clock frequency range | 8 | — | 33 | MHz |
| FPM multiplication factor (test condition is changed by a factor of 2) | 128 | — | 1024 | — |
| Lock-in time ¹ | — | — | 312.5 | μs |
| Cycle-to-cycle frequency jitter (peak to peak) | — | 8 | 20 | ns |

¹ plrf = 1 cycle assumed missed + x cycles for reset deassert + y cycles for calibration and lock x[ts] = {2,3,5,9}; y[ts] = {7,8,10,14}; where ts is the chosen time scale of the reference clock. In this case reference clock = 32 kHz which makes ts = 0, therefore total time required for achieving lock is 10(1+2+7) cycles or 312.5 μs.

4.7.6 High-Speed I²C (HS-I²C) Timing Parameters

This section describes the timing parameters of the HS-I²C module. This module can operate in the following modes: Standard, Fast and High speed.

NOTE

See the errata for the HS-I²C module in the i.MX51 Chip Errata. There are two standard I²C modules that have no errata.

4.7.6.1 Standard and Fast Mode Timing Parameters

Figure 47 depicts the standard and fast mode timings of HS-I²C module, and Table 75 lists the timing characteristics.

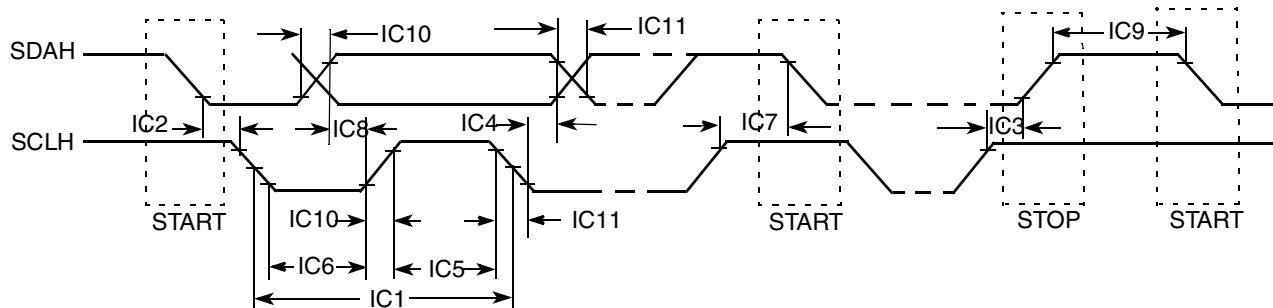

Figure 47. HS-I²C Standard and Fast Mode Bus Timing

Table 75. HS-I²C Timing Parameters—Standard and Fast Mode

| ID | Parameter | Standard Mode | | Fast Mode | | Unit |
|------|---|----------------|-------------------|-----------------------------------|------------------|------|
| | | Min | Max | Min | Max | |
| IC1 | SCLH cycle time | 10 | — | 2.5 | — | μs |
| IC2 | Hold time (repeated) START condition | 4.0 | — | 0.6 | — | μs |
| IC3 | Set-up time for STOP condition | 4.0 | — | 0.6 | — | μs |
| IC4 | Data hold time | 0 ¹ | 3.45 ² | 0 ¹ | 0.9 ² | μs |
| IC5 | HIGH Period of SCLH Clock | 4.0 | — | 0.6 | — | μs |
| IC6 | LOW Period of the SCLH Clock | 4.7 | — | 1.3 | — | μs |
| IC7 | Set-up time for a repeated START condition | 4.7 | — | 0.6 | — | μs |
| IC8 | Data set-up time | 250 | — | 100 ³ | — | ns |
| IC9 | Bus free time between a STOP and START condition | 4.7 | — | 1.3 | — | μs |
| IC10 | Rise time of both SDAH and SCLH signals | — | 1000 | 20+0.1C _b ⁴ | 300 | ns |
| IC11 | Fall time of both SDAH and SCLH signals | — | 300 | 20+0.1C _b ⁴ | 300 | ns |
| IC12 | Capacitive load for each bus line (C _b) | — | 100 | — | 100 | pF |

¹ A device must internally provide a hold time of at least 300 ns for SDAH signal in order to bridge the undefined region of the falling edge of SCLH.

² The maximum hold time has only to be met if the device does not stretch the LOW period (ID no IC6) of the SCLH signal

³ A Fast-mode I²C-bus device can be used in a Standard-mode I²C-bus system, but the requirement of Set-up time (ID No IC8) of 250 ns must then be met. This automatically is the case if the device does not stretch the LOW period of the SCLH signal.

If such a device does stretch the LOW period of the SCLH signal, it must output the next data bit to the SDAH line max_rise_time (ID No IC10) + data_setup_time (ID No IC8) = 1000 + 250 = 1250 ns (according to the Standard-mode I²C-bus specification) before the SCLH line is released.

⁴ C_b = total capacitance of one bus line in pF.

4.7.6.2 High-Speed Mode Timing Parameters

Figure 48 depicts the high-speed mode timings of HS-I²C module, and Table 76 lists the timing characteristics.

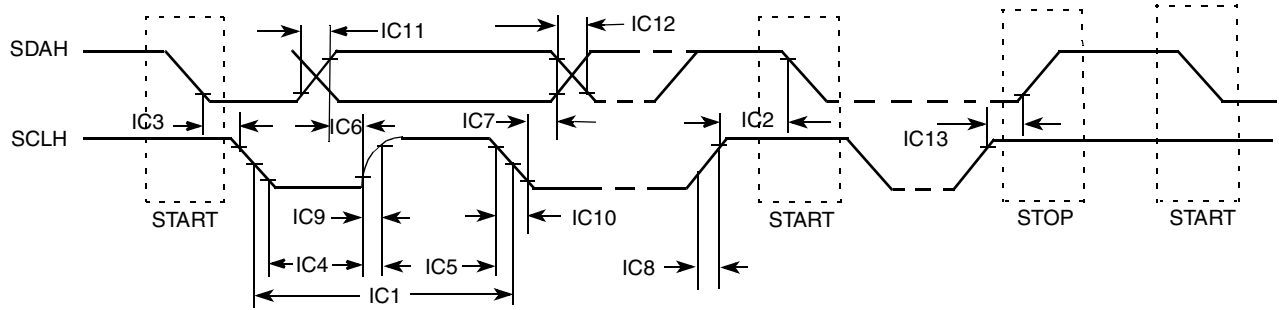

Figure 48. High-Speed Mode Timing

Table 76. HS-I²C High-Speed Mode Timing Parameters

| ID | Parameter | High-Speed Mode | | Unit |
|------|--|-----------------|-----|------|
| | | Min | Max | |
| IC1 | SCLH cycle time | 10 | 3.4 | MHz |
| IC2 | Setup time (repeated) START condition | 160 | — | ns |
| IC3 | Hold time (repeated) START condition | 160 | — | ns |
| IC4 | LOW Period of the SCLH Clock | 160 | — | ns |
| IC5 | HIGH Period of SCLH Clock | 60 | — | ns |
| IC6 | Data set-up time | 10 | — | ns |
| IC7 | Data hold time | 0 ¹ | 70 | ns |
| IC8 | Rise time of SCLH | 10 | 40 | ns |
| IC9 | Rise time of SCLH signal after a repeated START condition and after an acknowledge bit | 10 | 80 | ns |
| IC10 | Fall time of SCLH signal | 10 | 40 | ns |
| IC11 | Rise time of SDAH signal | 10 | 80 | ns |
| IC12 | Fall time of SDAH signal | 10 | 80 | ns |
| IC13 | Set-up time for STOP condition | 160 | — | ns |
| IC14 | Capacitive load for each bus line (C _b) | — | 100 | pF |

¹ A device must internally provide a hold time of at least 300 ns for SDAH signal in order to bridge the undefined region of the falling edge of SCLH.

4.7.7 I²C Module Timing Parameters

This section describes the timing parameters of the I²C Module. Figure 49 depicts the timing of I²C module, and Table 77 lists the I²C Module timing characteristics.

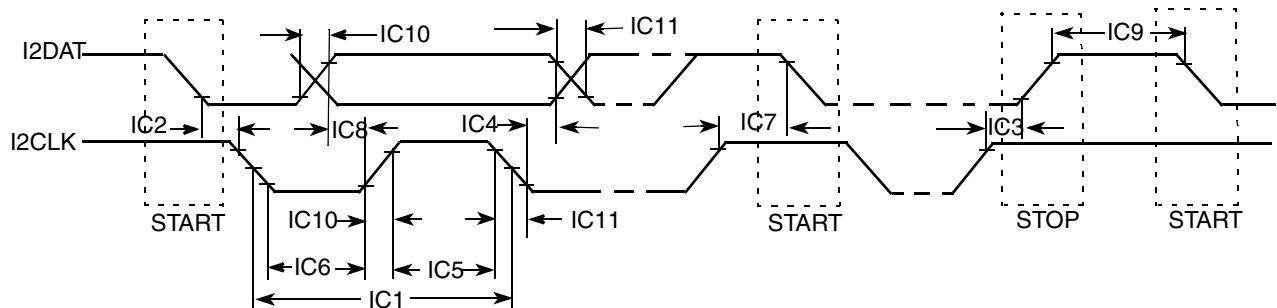

Figure 49. I²C Bus Timing

Table 77. I²C Module Timing Parameters

| ID | Parameter | Standard Mode Supply Voltage = 1.65 V–1.95 V, 2.7 V–3.3 V | | Fast Mode Supply Voltage = 2.7 V–3.3 V | | Unit |
|------|---|---|-------------------|--|------------------|------|
| | | Min | Max | Min | Max | |
| IC1 | I2CLK cycle time | 10 | — | 2.5 | — | μs |
| IC2 | Hold time (repeated) START condition | 4.0 | — | 0.6 | — | μs |
| IC3 | Set-up time for STOP condition | 4.0 | — | 0.6 | — | μs |
| IC4 | Data hold time | 0 ¹ | 3.45 ² | 0 ¹ | 0.9 ² | μs |
| IC5 | HIGH Period of I2CLK Clock | 4.0 | — | 0.6 | — | μs |
| IC6 | LOW Period of the I2CLK Clock | 4.7 | — | 1.3 | — | μs |
| IC7 | Set-up time for a repeated START condition | 4.7 | — | 0.6 | — | μs |
| IC8 | Data set-up time | 250 | — | 100 ³ | — | ns |
| IC9 | Bus free time between a STOP and START condition | 4.7 | — | 1.3 | — | μs |
| IC10 | Rise time of both I2DAT and I2CLK signals | — | 1000 | $20 + 0.1C_b^4$ | 300 | ns |
| IC11 | Fall time of both I2DAT and I2CLK signals | — | 300 | $20 + 0.1C_b^4$ | 300 | ns |
| IC12 | Capacitive load for each bus line (C _b) | — | 400 | — | 400 | pF |

¹ A device must internally provide a hold time of at least 300 ns for I2DAT signal in order to bridge the undefined region of the falling edge of I2CLK.

² The maximum hold time has only to be met if the device does not stretch the LOW period (ID no IC5) of the I2CLK signal

³ A Fast-mode I2C-bus device can be used in a Standard-mode I2C-bus system, but the requirement of Set-up time (ID No IC7) of 250 ns must be met. This automatically is the case if the device does not stretch the LOW period of the I2CLK signal. If such a device does stretch the LOW period of the I2CLK signal, it must output the next data bit to the I2DAT line $\text{max_rise_time (IC9)} + \text{data_setup_time (IC7)} = 1000 + 250 = 1250$ ns (according to the Standard-mode I2C-bus specification) before the I2CLK line is released.

⁴ C_b = total capacitance of one bus line in pF.

4.7.8 Image Processing Unit (IPU) Module Parameters

The purpose of the IPU is to provide comprehensive support for the flow of data from an image sensor and/or to a display device. This support covers all aspects of these activities:

- Connectivity to relevant devices—cameras, displays, graphics accelerators, and TV encoders.
- Related image processing and manipulation: display processing, image conversions, and other related functions.
- Synchronization and control capabilities such as avoidance of tearing artifacts.

4.7.8.1 Sensor Interface Timings

There are three camera timing modes supported by the IPU.

4.7.8.1.1 BT.656 and BT.1120 Video Mode

Smart camera sensors, which include imaging processing, usually support video mode transfer. They use an embedded timing syntax to replace the SENSB_VSYNC and SENSB_HSYNC signals. The timing syntax is defined by the BT.656/BT.1120 standards.

This operation mode follows the recommendations of ITU BT.656/ ITU BT.1120 specifications. The only control signal used is SENSB_PIX_CLK. Start-of-frame and active-line signals are embedded in the data stream. An active line starts with a SAV code and ends with a EAV code. In some cases, digital blanking is inserted in between EAV and SAV code. The CSI decodes and filters out the timing-coding from the data stream, thus recovering SENSB_VSYNC and SENSB_HSYNC signals for internal use. On BT.656 one component per cycle is received over the SENSB_DATA bus. On BT.1120 two components per cycle are received over the SENSB_DATA bus.

4.7.8.1.2 Gated Clock Mode

The SENSB_VSYNC, SENSB_HSYNC, and SENSB_PIX_CLK signals are used in this mode. See [Figure 50](#).

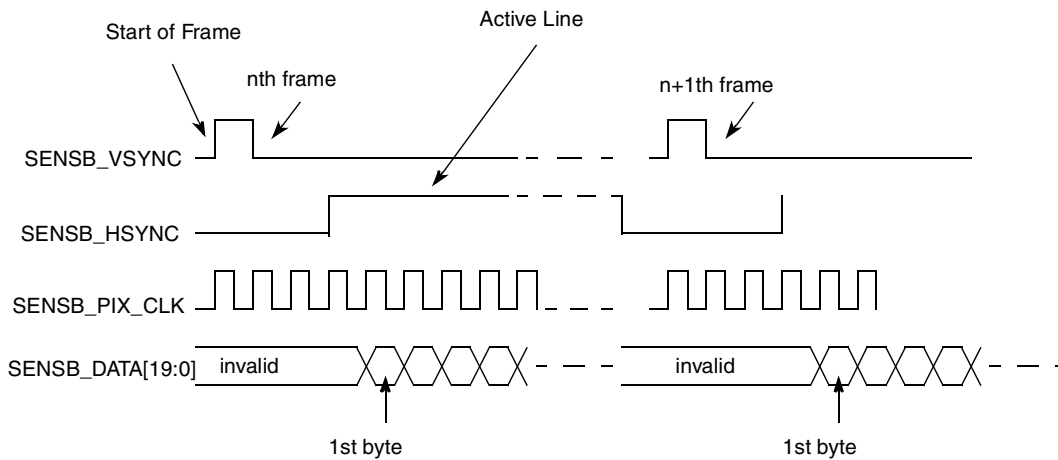

Figure 50. Gated Clock Mode Timing Diagram

A frame starts with a rising edge on SENS_B_VSYNC (all the timings correspond to straight polarity of the corresponding signals). Then SENS_B_HSYNC goes to high and hold for the entire line. Pixel clock is valid as long as SENS_B_HSYNC is high. Data is latched at the rising edge of the valid pixel clocks. SENS_B_HSYNC goes to low at the end of line. Pixel clocks then become invalid and the CSI stops receiving data from the stream. For next line the SENS_B_HSYNC timing repeats. For next frame the SENS_B_VSYNC timing repeats.

4.7.8.1.3 Non-Gated Clock Mode

The timing is the same as the gated-clock mode (described in [Section 4.7.8.1.2, “Gated Clock Mode”](#)), except for the SENS_B_HSYNC signal, which is not used. See [Figure 51](#). All incoming pixel clocks are valid and cause data to be latched into the input FIFO. The SENS_B_PIX_CLK signal is inactive (states low) until valid data is going to be transmitted over the bus.

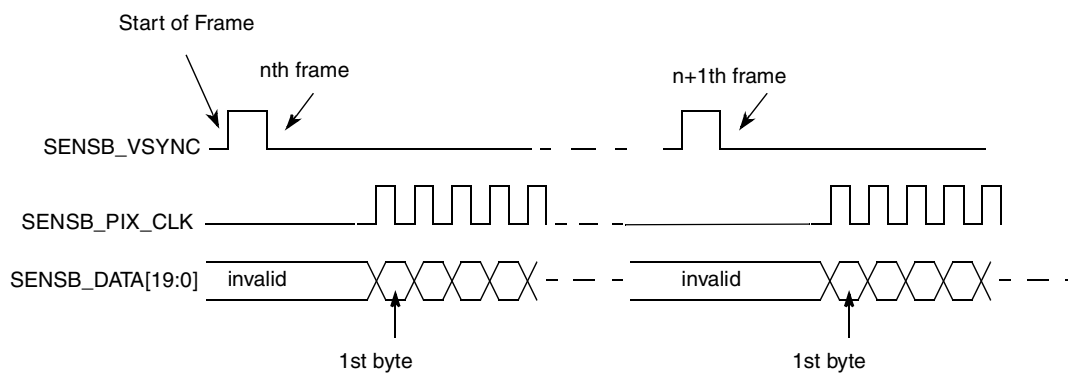

Figure 51. Non-Gated Clock Mode Timing Diagram

The timing described in [Figure 51](#) is that of a typical sensor. Some other sensors may have a slightly different timing. The CSI can be programmed to support rising/falling-edge triggered SENS_B_VSYNC; active-high/low SENS_B_HSYNC; and rising/falling-edge triggered SENS_B_PIX_CLK.

4.7.8.2 Electrical Characteristics

[Figure 52](#) shows the sensor interface timing diagram. SENS_B_PIX_CLK signal described here is not generated by the IPU. [Table 78](#) shows the timing characteristics for the diagram shown in [Figure 52](#).

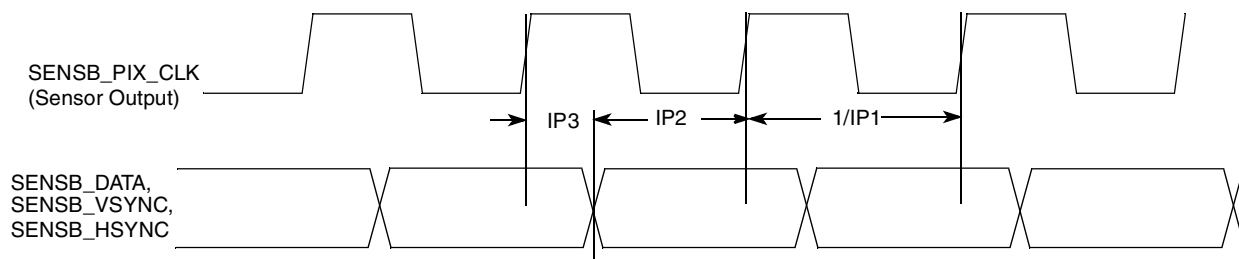

Figure 52. Sensor Interface Timing Diagram

Table 78. Sensor Interface Timing Characteristics

| ID | Parameter | Symbol | Min | Max | Unit |
|-----|---------------------------------------|--------|------|-----|------|
| IP1 | Sensor output (pixel) clock frequency | Fpck | 0.01 | 120 | MHz |
| IP2 | Data and control setup time | Tsu | 3 | — | ns |
| IP3 | Data and control holdup time | Thd | 2 | — | ns |

4.7.8.3 IPU Display Interface Signal Mapping

The IPU supports a number of display output video formats. [Table 79](#) defines the mapping of the Display Interface Pins used during various supported video interface formats.

Table 79. Video Signal Cross-Reference

| i.MX51 | LCD | | | | | | | | Comment ¹ |
|----------------------|-------------------------------------|------------------------------------|---------------|---------------|-----------------------------|-----------------|-----------------|----------------|---|
| Port Name (x=1,2) | RGB, Signal Name (General) | RGB/TV Signal Allocation (Example) | | | | | | Smart | |
| | | 16-bit RGB | 18-bit RGB | 24-bit RGB | 8-bit YCrCb ² | 16-bit YCrCb | 20-bit YCrCb | Signal Name | |
| DISPx_DAT0 | DAT[0] | B[0] | B[0] | B[0] | Y/C[0] | C[0] | C[0] | DAT[0] | <p>The restrictions are as follows:</p> <p>a) There are maximal three continuous groups of bits that could be independently mapped to the external bus.</p> <p>Groups should not be overlapped.</p> <p>b) The bit order is expressed in each of the bit groups, for example B[0] = least significant blue pixel bit</p> |
| DISPx_DAT1 | DAT[1] | B[1] | B[1] | B[1] | Y/C[1] | C[1] | C[1] | DAT[1] | |
| DISPx_DAT2 | DAT[2] | B[2] | B[2] | B[2] | Y/C[2] | C[2] | C[2] | DAT[2] | |
| DISPx_DAT3 | DAT[3] | B[3] | B[3] | B[3] | Y/C[3] | C[3] | C[3] | DAT[3] | |
| DISPx_DAT4 | DAT[4] | B[4] | B[4] | B[4] | Y/C[4] | C[4] | C[4] | DAT[4] | |
| DISPx_DAT5 | DAT[5] | G[0] | B[5] | B[5] | Y/C[5] | C[5] | C[5] | DAT[5] | |
| DISPx_DAT6 | DAT[6] | G[1] | G[0] | B[6] | Y/C[6] | C[6] | C[6] | DAT[6] | |
| DISPx_DAT7 | DAT[7] | G[2] | G[1] | B[7] | Y/C[7] | C[7] | C[7] | DAT[7] | |
| DISPx_DAT8 | DAT[8] | G[3] | G[2] | G[0] | — | Y[0] | C[8] | DAT[8] | |
| DISPx_DAT9 | DAT[9] | G[4] | G[3] | G[1] | — | Y[1] | C[9] | DAT[9] | |
| DISPx_DAT10 | DAT[10] | G[5] | G[4] | G[2] | — | Y[2] | Y[0] | DAT[10] | |
| DISPx_DAT11 | DAT[11] | R[0] | G[5] | G[3] | — | Y[3] | Y[1] | DAT[11] | |
| DISPx_DAT12 | DAT[12] | R[1] | R[0] | G[4] | — | Y[4] | Y[2] | DAT[12] | |
| DISPx_DAT13 | DAT[13] | R[2] | R[1] | G[5] | — | Y[5] | Y[3] | DAT[13] | |
| DISPx_DAT14 | DAT[14] | R[3] | R[2] | G[6] | — | Y[6] | Y[4] | DAT[14] | |
| DISPx_DAT15 | DAT[15] | R[4] | R[3] | G[7] | — | Y[7] | Y[5] | DAT[15] | |
| DISPx_DAT16 | DAT[16] | — | R[4] | R[0] | — | — | Y[6] | — | |
| DISPx_DAT17 | DAT[17] | — | R[5] | R[1] | — | — | Y[7] | — | |
| DISPx_DAT18 | DAT[18] | — | — | R[2] | — | — | Y[8] | — | |
| DISPx_DAT19 | DAT[19] | — | — | R[3] | — | — | Y[9] | — | |
| DISPx_DAT20 | DAT[20] | — | — | R[4] | — | — | — | — | |
| DISPx_DAT21 | DAT[21] | — | — | R[5] | — | — | — | — | |

Table 79. Video Signal Cross-Reference (continued)

| i.MX51 | LCD | | | | | | | | Comment ¹ |
|----------------------|-------------------------------------|------------------------------------|---------------|---------------|-----------------------------|-----------------|-----------------|----------------|---|
| Port Name (x=1,2) | RGB, Signal Name (General) | RGB/TV Signal Allocation (Example) | | | | | | Smart | |
| | | 16-bit RGB | 18-bit RGB | 24-bit RGB | 8-bit YCrCb ² | 16-bit YCrCb | 20-bit YCrCb | Signal Name | |
| DISPx_DAT22 | DAT[22] | — | — | R[6] | — | — | — | — | — |
| DISPx_DAT23 | DAT[23] | — | — | R[7] | — | — | — | — | — |
| Dlx_DISP_CLK | PixCLK | | | | | | | — | — |
| Dlx_PIN1 | — | | | | | | | VSYNC_IN | May be required for anti-tearing |
| Dlx_PIN2 | HSYNC | | | | | | | — | — |
| Dlx_PIN3 | VSYNC | | | | | | | — | VSYNC out |
| Dlx_PIN4 | — | | | | | | | — | Additional frame/row synchronous signals with programmable timing |
| Dlx_PIN5 | — | | | | | | | — | |
| Dlx_PIN6 | — | | | | | | | — | |
| Dlx_PIN7 | — | | | | | | | — | |
| Dlx_PIN8 | — | | | | | | | — | |
| Dlx_D0_CS | — | | | | | | | CS0 | — |
| Dlx_D1_CS | — | | | | | | | CS1 | Alternate mode of PWM output for contrast or brightness control |
| Dlx_PIN11 | — | | | | | | | WR | — |
| Dlx_PIN12 | — | | | | | | | RD | — |
| Dlx_PIN13 | — | | | | | | | RS1 | Register select signal |
| Dlx_PIN14 | — | | | | | | | RS2 | Optional RS2 |
| Dlx_PIN15 | DRDY/DV | | | | | | | DRDY | Data validation/blank, data enable |
| Dlx_PIN16 | — | | | | | | | — | Additional data synchronous signals with programmable features/timing |
| Dlx_PIN17 | Q | | | | | | | — | |

¹ Signal mapping (both data and control/synchronization) is flexible. The table provides examples.

² This mode works in compliance with recommendation ITU-R BT.656. The timing reference signals (frame start, frame end, line start, and line end) are embedded in the 8-bit data bus. Only video data is supported, transmission of non-video related data during blanking intervals is not supported.

4.7.8.4 IPU Display Interface Timing

The IPU Display Interface supports two kinds of display's accesses: synchronous and asynchronous. There are two groups of external interface pins to provide synchronous and asynchronous controls accordantly.

4.7.8.4.1 Synchronous Controls

The synchronous control is a signal that changes its value as a function either of a system or of an external clock. This control has a permanent period and a permanent wave form.

There are special physical outputs to provide synchronous controls:

- The `ipp_disp_clk` is a dedicated base synchronous signal that is used to generate a base display (component, pixel) clock for a display.
- The `ipp_pin_1–ipp_pin_7` are general purpose synchronous pins, that can be used to provide HSYNC, VSYNC, DRDY or any else independent signal to a display.

The IPU has a system of internal binding counters for internal events (like HSYNC/VSYCN and so on) calculation. The internal event (local start point) is synchronized with internal `DI_CLK`. A suitable control starts from the local start point with predefined UP and DOWN values to calculate control's changing points with half `DI_CLK` resolution. A full description of the counters system is in the IPU chapter of the *i.MX51 Multimedia Applications Processor Reference Manual* (MCIMX51RM).

4.7.8.4.2 Asynchronous Controls

The asynchronous control is a data oriented signal that changes its a value with an output data according to an additional internal flags coming with the data.

There are special physical outputs to provide asynchronous controls, as follows:

- The `ipp_d0_cs` and `ipp_d1_cspins` are dedicated to provide chip select signals to two displays
- The `ipp_pin_11–ipp_pin_17` are general purpose asynchronous pins, that can be used to provide WR, RD, RS or any else data oriented signal to display.

NOTE

The IPU has independent signal generators for asynchronous signals toggling. When a DI decides to put a new asynchronous data in the bus, a new internal start (local start point) is generated. The signals generators calculate predefined UP and DOWN values to change pins states with half `DI_CLK` resolution.

4.7.8.5 Synchronous Interfaces to Standard Active Matrix TFT LCD Panels

4.7.8.5.1 IPU Display Operating Signals

The IPU uses four control signals and data to operate a standard synchronous interface:

- `IPP_DISP_CLK`—Clock to display
- `HSYNC`—Horizontal synchronization

Electrical Characteristics

- VSYNC—Vertical synchronization
- DRDY—Active data

All synchronous display controls are generated on base of an internal generated “local start point”. The synchronous display controls can be placed on time axis with DI’s offset, up and down parameters. The display access can be whole number of DI clock (T_{diclk}) only. The IPP_DATA can not be moved relative to the local start point.

4.7.8.5.2 LCD Interface Functional Description

Figure 53 depicts the LCD interface timing for a generic active matrix color TFT panel. In this figure signals are shown with negative polarity. The sequence of events for active matrix interface timing is:

- DI_CLK internal DI clock, used for calculation of other controls.
- IPP_DISP_CLK latches data into the panel on its negative edge (when positive polarity is selected). In active mode, IPP_DISP_CLK runs continuously.
- HSYNC causes the panel to start a new line. (Usually IPP_PIN_2 is used as HSYNC)
- VSYNC causes the panel to start a new frame. It always encompasses at least one HSYNC pulse. (Usually IPP_PIN_3 is used as VSYNC)
- DRDY acts like an output enable signal to the CRT display. This output enables the data to be shifted onto the display. When disabled, the data is invalid and the trace is off. (For DRDY can be used either synchronous or asynchronous generic purpose pin as well.)

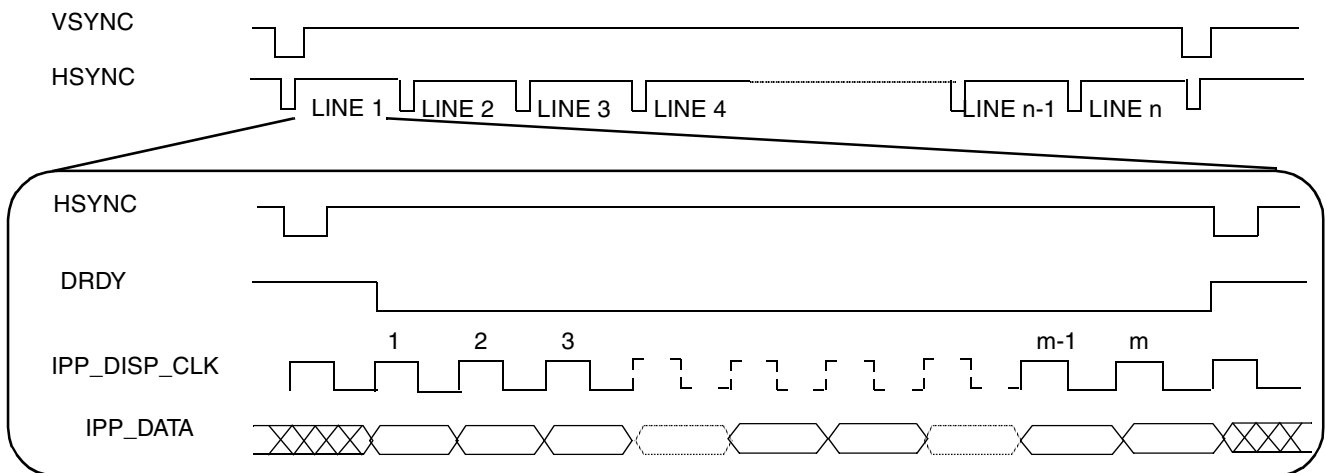

Figure 53. Interface Timing Diagram for TFT (Active Matrix) Panels

4.7.8.5.3 TFT Panel Sync Pulse Timing Diagrams

Figure 54 depicts the horizontal timing (timing of one line), including both the horizontal sync pulse and the data. All shown on the figure parameters are programmable. All controls are started by corresponding

internal events—local start points. The timing diagrams correspond to inverse polarity of the IPP_DISP_CLK signal and active-low polarity of the HSYNC, VSYNC and DRDY signals.

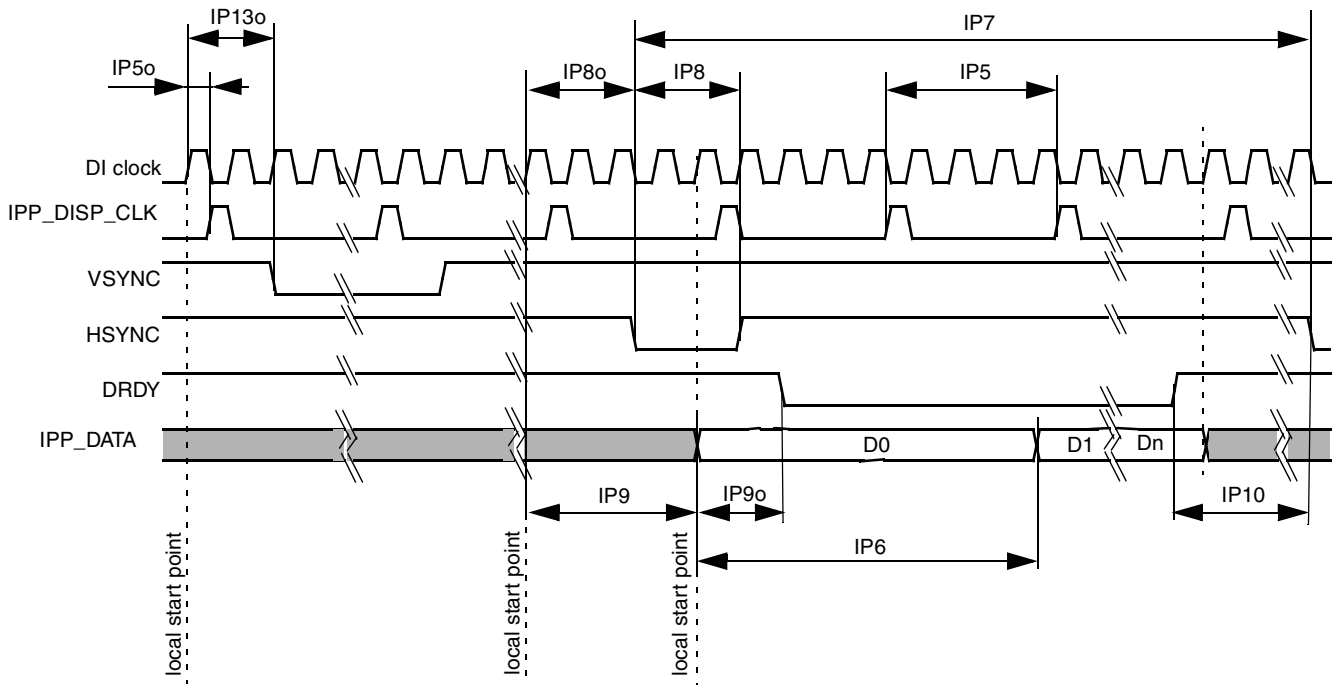

Figure 54. TFT Panels Timing Diagram—Horizontal Sync Pulse

Figure 55 depicts the vertical timing (timing of one frame). All parameters shown in the figure are programmable.

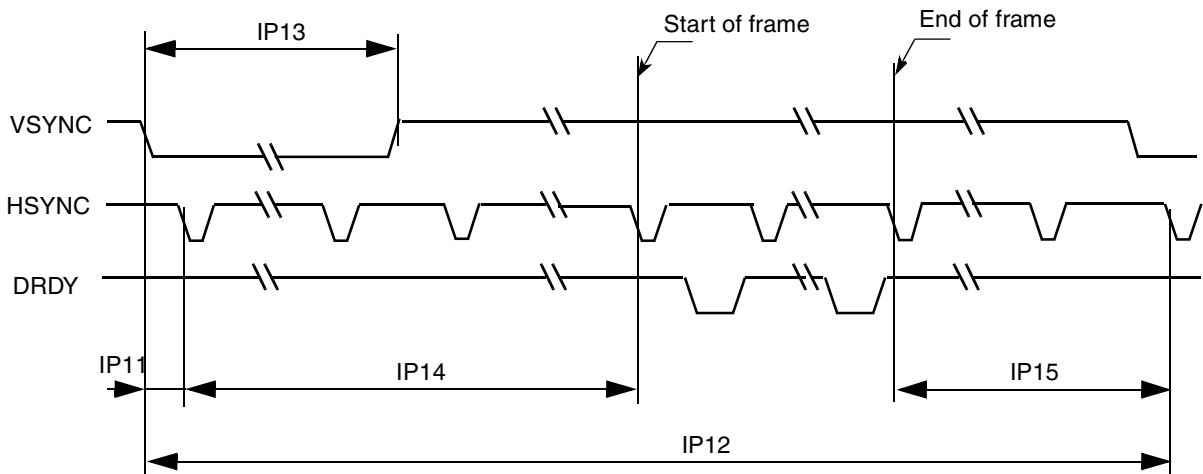

Figure 55. TFT Panels Timing Diagram—Vertical Sync Pulse

Electrical Characteristics

Table 80 shows timing characteristics of signals presented in Figure 54 and Figure 55.

Table 80. Synchronous Display Interface Timing Characteristics (Pixel Level)

| ID | Parameter | Symbol | Value | Description | Unit |
|------|--------------------------------|--------|---------------------------------------|--|------|
| IP5 | Display interface clock period | Tdicp | (¹) | Display interface clock. IPP_DISP_CLK | ns |
| IP6 | Display pixel clock period | Tdpcp | DISP_CLK_PER_PIXEL × Tdicp | Time of translation of one pixel to display, DISP_CLK_PER_PIXEL—number of pixel components in one pixel (1.n). The DISP_CLK_PER_PIXEL is virtual parameter to define Display pixel clock period. The DISP_CLK_PER_PIXEL is received by DC/DI one access division to n components. | ns |
| IP7 | Screen width time | Tsw | (SCREEN_WIDTH) × Tdicp | SCREEN_WIDTH—screen width in, interface clocks. horizontal blanking included. The SCREEN_WIDTH should be built by suitable DI's counter ² . | ns |
| IP8 | HSYNC width time | Thsw | (HSYNC_WIDTH) | HSYNC_WIDTH—Hsync width in DI_CLK with 0.5 DI_CLK resolution. Defined by DI's counter. | ns |
| IP9 | Horizontal blank interval 1 | Thbi1 | BGXP × Tdicp | BGXP—Width of a horizontal blanking before a first active data in a line. (in interface clocks). The BGXP should be built by suitable DI's counter. | ns |
| IP10 | Horizontal blank interval 2 | Thbi2 | (SCREEN_WIDTH - BGXP - FW) × Tdicp | Width a horizontal blanking after a last active data in a line. (in interface clocks) FW—width of active line in interface clocks. The FW should be built by suitable DI's counter. | ns |
| IP12 | Screen height | Tsh | (SCREEN_HEIGHT) × Tsw | SCREEN_HEIGHT— screen height in lines with blanking The SCREEN_HEIGHT is a distance between 2 VSYNCs. The SCREEN_HEIGHT should be built by suitable DI's counter. | ns |
| IP13 | VSYNC width | Tvsw | VSYNC_WIDTH | VSYNC_WIDTH—Vsync width in DI_CLK with 0.5 DI_CLK resolution. Defined by DI's counter | ns |
| IP14 | Vertical blank interval 1 | Tvbi1 | BGYP × Tsw | BGYP—width of first Vertical blanking interval in line.The BGYP should be built by suitable DI's counter. | ns |
| IP15 | Vertical blank interval 2 | Tvbi2 | (SCREEN_HEIGHT - BGYP - FH) × Tsw | width of second Vertical blanking interval in line.The FH should be built by suitable DI's counter. | ns |

Table 80. Synchronous Display Interface Timing Characteristics (Pixel Level) (continued)

| ID | Parameter | Symbol | Value | Description | Unit |
|-------|------------------------|--------|-----------------------------|---|------|
| IP5o | Offset of IPP_DISP_CLK | Todicp | DISP_CLK_OFFSET × Tdiclk | DISP_CLK_OFFSET— offset of IPP_DISP_CLK edges from local start point, in DI_CLK×2 (0.5 DI_CLK Resolution) Defined by DISP_CLK counter | ns |
| IP13o | Offset of VSYNC | Tovs | VSYNC_OFFSET × Tdiclk | VSYNC_OFFSET—offset of Vsync edges from a local start point, when a Vsync should be active, in DI_CLK×2 (0.5 DI_CLK Resolution). The VSYNC_OFFSET should be built by suitable DI's counter. | ns |
| IP8o | Offset of HSYNC | Tohs | HSYNC_OFFSET × Tdiclk | HSYNC_OFFSET—offset of Hsync edges from a local start point, when a Hsync should be active, in DI_CLK×2 (0.5 DI_CLK Resolution). The HSYNC_OFFSET should be built by suitable DI's counter. | ns |
| IP9o | Offset of DRDY | Todrdy | DRDY_OFFSET × Tdiclk | DRDY_OFFSET— offset of DRDY edges from a suitable local start point, when a corresponding data has been set on the bus, in DI_CLK×2 (0.5 DI_CLK Resolution) The DRDY_OFFSET should be built by suitable DI's counter. | ns |

¹ Display interface clock period immediate value.

$$T_{dicp} = \begin{cases} T_{diclk} \times \frac{DISP_CLK_PERIOD}{DI_CLK_PERIOD}, & \text{for integer } \frac{DISP_CLK_PERIOD}{DI_CLK_PERIOD} \\ T_{diclk} \left(\text{floor} \left[\frac{DISP_CLK_PERIOD}{DI_CLK_PERIOD} \right] + 0.5 \pm 0.5 \right), & \text{for fractional } \frac{DISP_CLK_PERIOD}{DI_CLK_PERIOD} \end{cases}$$

DISP_CLK_PERIOD—number of DI_CLK per one Tdicp. Resolution 1/16 of DI_CLK

DI_CLK_PERIOD—relation of between programing clock frequency and current system clock frequency

Display interface clock period average value.

$$\bar{T}_{dicp} = T_{diclk} \times \frac{DISP_CLK_PERIOD}{DI_CLK_PERIOD}$$

² DI's counter can define offset, period and UP/DOWN characteristic of output signal according to programed parameters of the counter. Same of parameters in the table are not defined by DI's registers directly (by name), but can be generated by corresponding DI's counter. The SCREEN_WIDTH is an input value for DI's HSYNC generation counter. The distance between HSYNCs is a SCREEN_WIDTH.

The maximal accuracy of UP/DOWN edge of controls is

$$\text{Accuracy} = (0.5 \times T_{diclk}) \pm 0.75\text{ns}$$

Electrical Characteristics

The maximal accuracy of UP/DOWN edge of IPP_DATA is

$$\text{Accuracy} = T_{\text{dclk}} \pm 0.75\text{ns}$$

The DISP_CLK_PERIOD, DI_CLK_PERIOD parameters are programmed via registers.

Figure 56 shows the synchronous display interface timing diagram for access level. The DISP_CLK_DOWN and DISP_CLK_UP parameters are set by using the register. Table 81 shows the timing characteristics for the diagram shown in Figure 56.

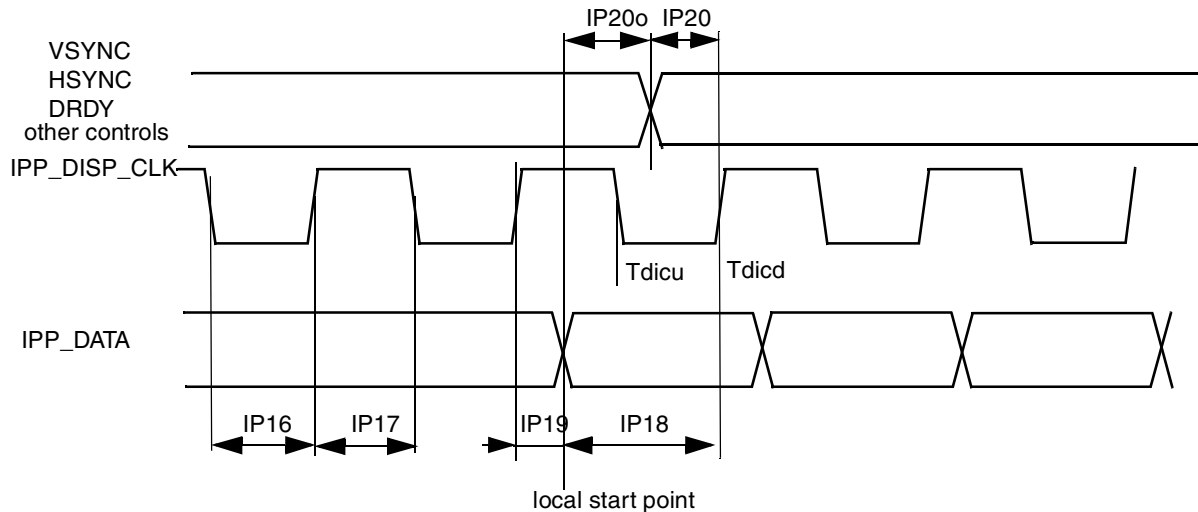

Figure 56. Synchronous Display Interface Timing Diagram—Access Level

Table 81. Synchronous Display Interface Timing Characteristics (Access Level)

| ID | Parameter | Symbol | Min | Typ ¹ | Max | Unit |
|-------|--|--------|-----------------------|--|-----------------------|------|
| IP16 | Display interface clock low time | Tckl | Tdicd-Tdicu-1.5 | Tdicd ² -Tdicu ³ | Tdicd-Tdicu+1.5 | ns |
| IP17 | Display interface clock high time | Tckh | Tdicp-Tdicd+Tdicu-1.5 | Tdicp-Tdicd+Tdicu | Tdicp-Tdicd+Tdicu+1.5 | ns |
| IP18 | Data setup time | Tdsu | Tdicd-1.5 | Tdicu | — | ns |
| IP19 | Data holdup time | Tdhd | Tdicp-Tdicd-1.5 | Tdicp-Tdicu | — | ns |
| IP20o | Control signals offset times (defines for each pin) | Tocsu | Tocsu-1.5 | Tocsu | Tocsu+1.5 | — |
| IP20 | Control signals setup time to display interface clock (defines for each pin) | Tcsu | Tdicd-1.5-Tocsu%Tdicp | Tdicu | — | ns |

¹The exact conditions have not been finalized, but will likely match the current customer requirement for their specific display. These conditions may be chip specific.

² Display interface clock down time

$$T_{dicd} = \frac{1}{2} \left(T_{diclk} \times \text{ceil} \left[\frac{2 \times \text{DISP_CLK_DOWN}}{\text{DI_CLK_PERIOD}} \right] \right)$$

³ Display interface clock up time

$$T_{dicu} = \frac{1}{2} \left(T_{diclk} \times \text{ceil} \left[\frac{2 \times \text{DISP_CLK_UP}}{\text{DI_CLK_PERIOD}} \right] \right)$$

where CEIL(X) rounds the elements of X to the nearest integers towards infinity.

4.7.8.6 Interface to a TV Encoder

The interface has an 8-bit data bus, transferring a single 8-bit value (Y/U/V) in each cycle. The timing of the interface is described in [Figure 57](#).

NOTE

- The frequency of the clock DISP_CLK is 27 MHz (within 10%)
- The HSYNC, VSYNC signals are active low.
- The DRDY signal is shown as active high.
- The transition to the next row is marked by the negative edge of the HSYNC signal. It remains low for a single clock cycle
- The transition to the next field/frame is marked by the negative edge of the VSYNC signal. It remains low for at least one clock cycles
 - At a transition to an odd field (of the next frame), the negative edges of VSYNC and HSYNC coincide.
 - At a transition is to an even field (of the same frame), they do not coincide.
- The active intervals—during which data is transferred—are marked by the HSYNC signal being high.

Electrical Characteristics

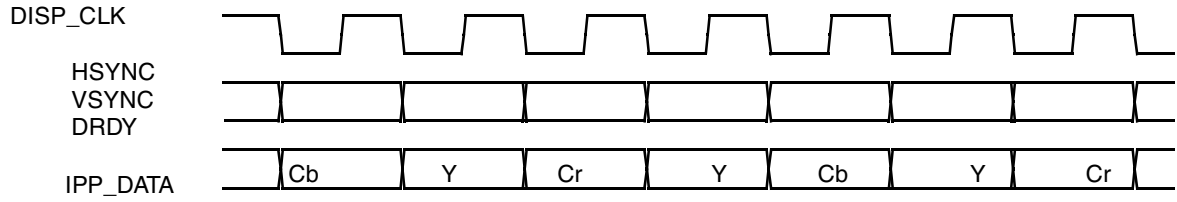

Pixel Data Timing

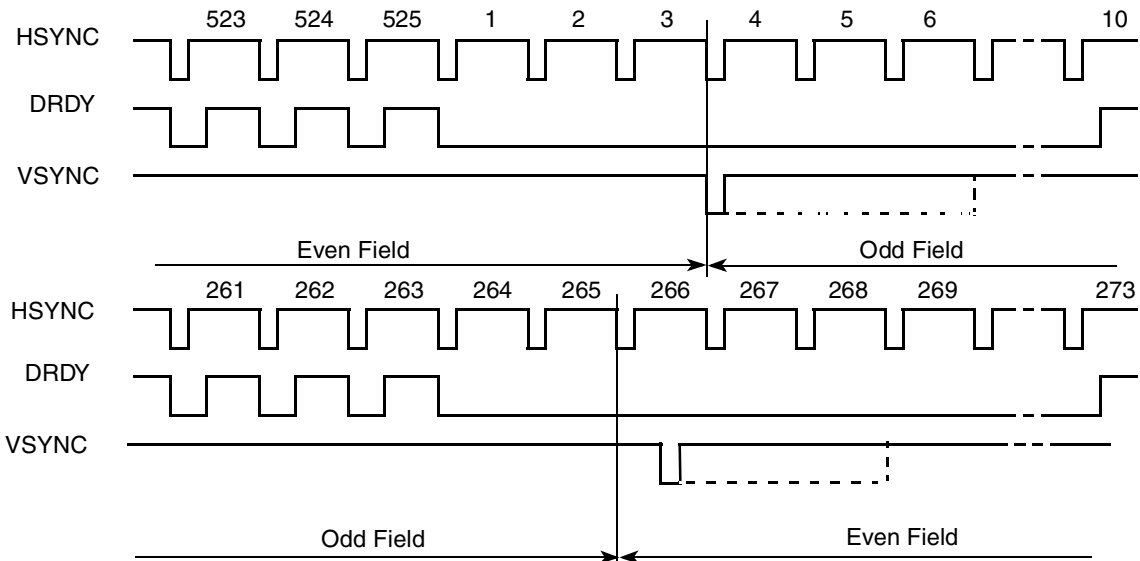

Line and Field Timing - NTSC

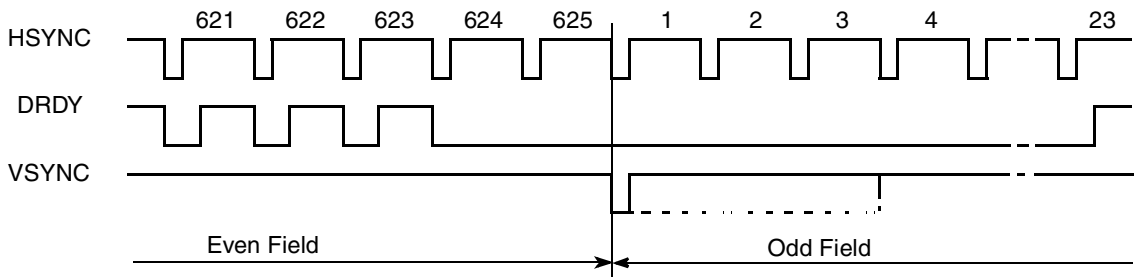

Line and Field Timing - PAL

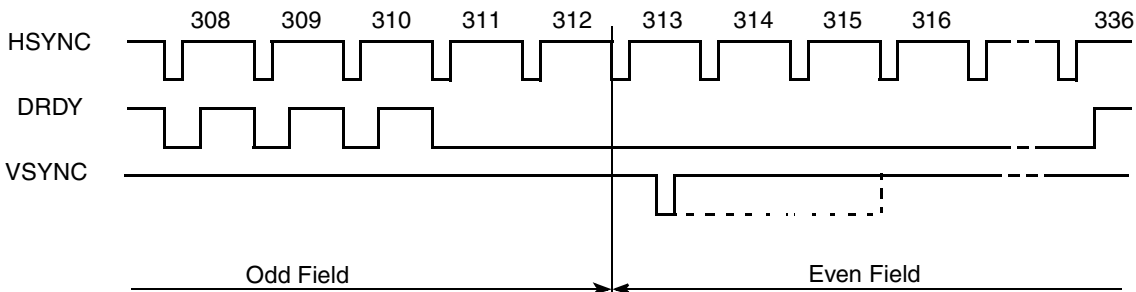

Figure 57. TV Encoder Interface Timing Diagram

4.7.8.6.1 TV Encoder Performance Specifications

All the parameters in the table are defined under the following conditions:

Rset = 1.05 kΩ ±1%, resistor on VREFOUT pin to Ground

Rload = 37.5 Ω ±1%, output load to Ground

The TV encoder output specifications are shown in [Table 82](#).

Table 82. TV Encoder Video Performance Specifications

| Parameter | Conditions | Min | Typ | Max | Unit |
|--|--|------|------|------|----------|
| DAC STATIC PERFORMANCE | | | | | |
| Resolution ¹ | — | — | 10 | — | Bits |
| Integral Nonlinearity (INL) ² | — | — | 1 | 2 | LSBs |
| Differential Nonlinearity (DNL) ² | — | — | 0.6 | 1 | LSBs |
| Channel-to-channel gain matching ² | — | — | 2 | — | % |
| Full scale output voltage ² | Rset = 1.05 kΩ ±1% Rload = 37.5 Ω±1% | 1.24 | 1.35 | 1.45 | V |
| DAC DYNAMIC PERFORMANCE | | | | | |
| Spurious Free Dynamic Range (SFDR) | F _{out} = 3.38 MHz F _{samp} = 216 MHz | — | 59 | — | dBc |
| Spurious Free Dynamic Range (SFDR) | F _{out} = 9.28 MHz F _{samp} = 297 MHz | — | 54 | — | dBc |
| VIDEO PERFORMANCE IN SD MODE^{2, 3} | | | | | |
| Short Term Jitter (Line to Line) | — | — | 2.5 | — | ±ns |
| Long Term Jitter (Field to Field) | — | — | 3.5 | — | ±ns |
| Frequency Response | 0-4.0 MHz | -0.1 | — | 0.1 | dB |
| | 5.75 MHz | -0.7 | — | 0 | dB |
| Luminance Nonlinearity | — | — | 0.5 | — | ±% |
| Differential Gain | — | — | 0.35 | — | % |
| Differential Phase | — | — | 0.6 | — | Degrees |
| Signal-to-Noise Ratio (SNR) | Flat field full bandwidth | — | 75 | — | dB |
| Hue Accuracy | — | — | 0.8 | — | ±Degrees |
| Color Saturation Accuracy | — | — | 1.5 | — | ±% |
| Chroma AM Noise | — | — | -70 | — | dB |
| Chroma PM Noise | — | — | -47 | — | dB |
| Chroma Nonlinear Phase | — | — | 0.5 | — | ±Degrees |
| Chroma Nonlinear Gain | — | — | 2.5 | — | ±% |
| Chroma/Luma Intermodulation | — | — | 0.1 | — | ±% |

Table 82. TV Encoder Video Performance Specifications (continued)

| | | | | | |
|---|-----------------------------|------|-----|-----|-----|
| Chroma/Luma Gain Inequality | — | — | 1.0 | — | ±% |
| Chroma/Luma Delay Inequality | — | — | 1.0 | — | ±ns |
| | — | — | — | — | — |
| VIDEO PERFORMANCE IN HD MODE² | | | | | |
| Luma Frequency Response | 0-30 MHz | -0.2 | — | 0.2 | dB |
| Chroma Frequency Response | 0-15 MHz, YCbCr 422 mode | -0.2 | — | 0.2 | dB |
| Luma Nonlinearity | — | — | 3.2 | — | % |
| Chroma Nonlinearity | — | — | 3.4 | — | % |
| Luma Signal-to-Noise Ratio | 0-30 MHz | — | 62 | — | dB |
| Chroma Signal-to-Noise Ratio | 0-15 MHz | — | 72 | — | dB |

¹ Guaranteed by design

² Guaranteed by characterization

³ R_{set} = VREFOUT's external resistor to ground = 1.05 k Ω

4.7.8.7 Asynchronous Interfaces

4.7.8.7.1 Standard Parallel Interfaces

The IPU has four signal generator machines for asynchronous signal. Each machine generates IPU's internal control levels (0 or 1) by UP and DOWN are defined in Registers. Each asynchronous pin has a dynamic connection with one of the signal generators. This connection is redefined again with a new display access (pixel/component) The IPU can generate control signals according to system 80/68 requirements. The burst length is received as a result from predefined behavior of the internal signal generator machines.

The access to a display is realized by the following:

- CS (IPP_CS) chip select
- WR (IPP_PIN_11) write strobe
- RD (IPP_PIN_12) read strobe
- RS (IPP_PIN_13) Register select (A0)

Both system 80 and system 68k interfaces are supported for all described modes as depicted in [Figure 58](#), [Figure 59](#), [Figure 60](#), and [Figure 61](#). The timing images correspond to active-low IPP_CS, WR and RD signals.

Each asynchronous access is defined by an access size parameter. This parameter can be different between different kinds of accesses. This parameter defines a length of windows, when suitable controls of the current access are valid. A pause between two different display accesses can be guaranteed by programming of suitable access sizes. There are no minimal/maximal hold/setup time hard defined by DI. Each control signal can be switched at any time during access size.

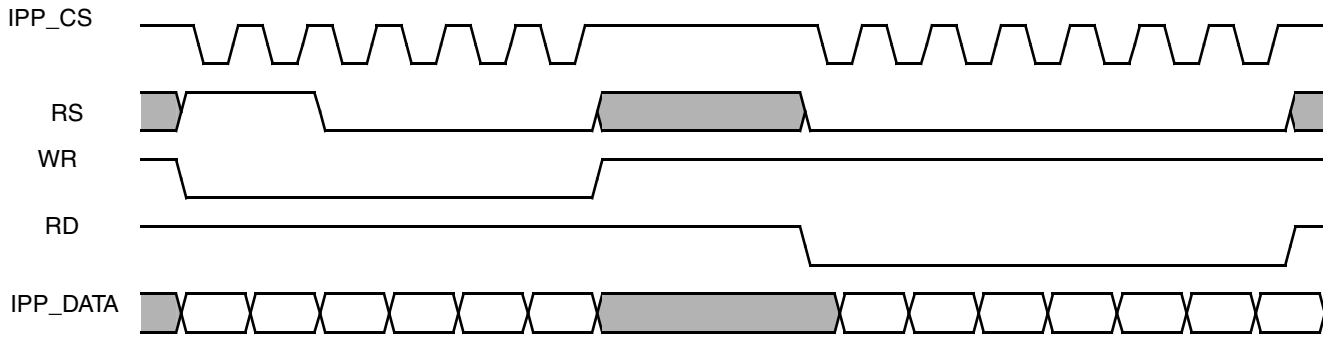

Burst access mode with sampling by CS signal

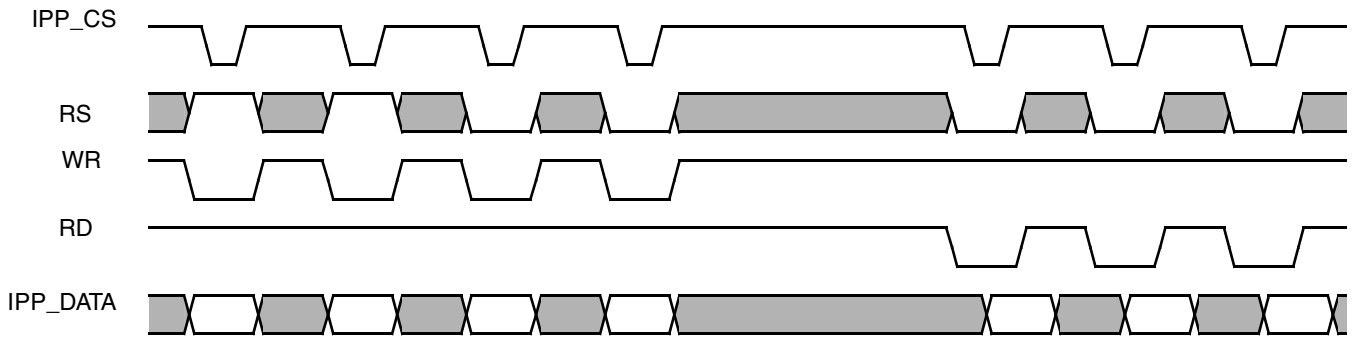

Single access mode (all control signals are not active for one display interface clock after each display access)

Figure 58. Asynchronous Parallel System 80 Interface (Type 1) Timing Diagram

Electrical Characteristics

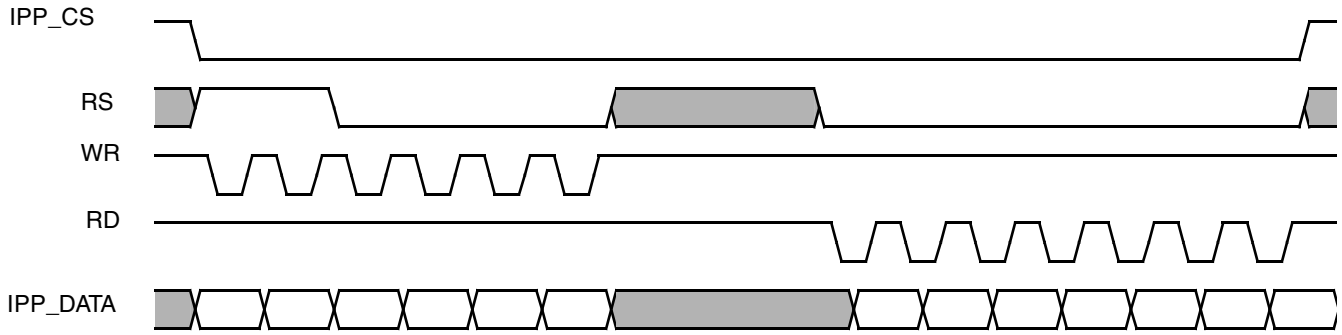

Burst access mode with sampling by WR/RD signals

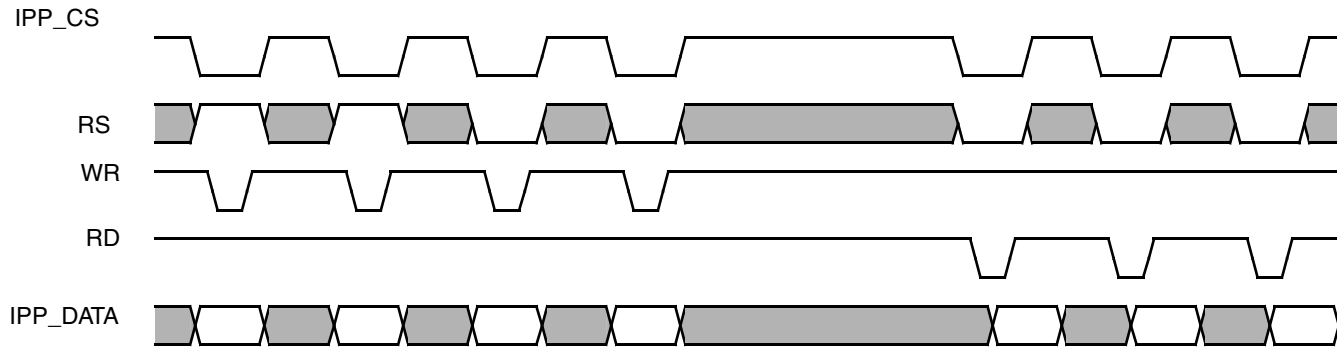

Single access mode (all control signals are not active for one display interface clock after each display access)

Figure 59. Asynchronous Parallel System 80 Interface (Type 2) Timing Diagram

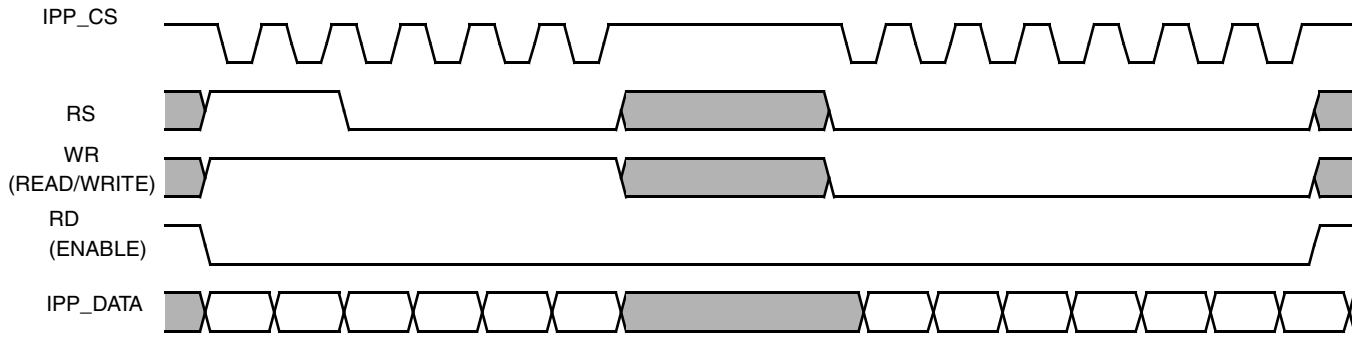

Burst access mode with sampling by CS signal

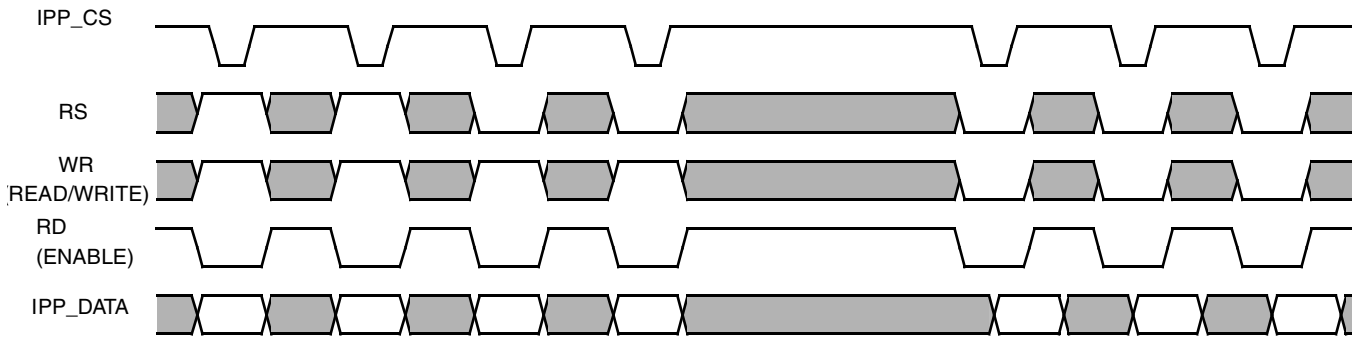

Single access mode (all control signals are not active for one display interface clock after each display access)

Figure 60. Asynchronous Parallel System 68k Interface (Type 1) Timing Diagram

Electrical Characteristics

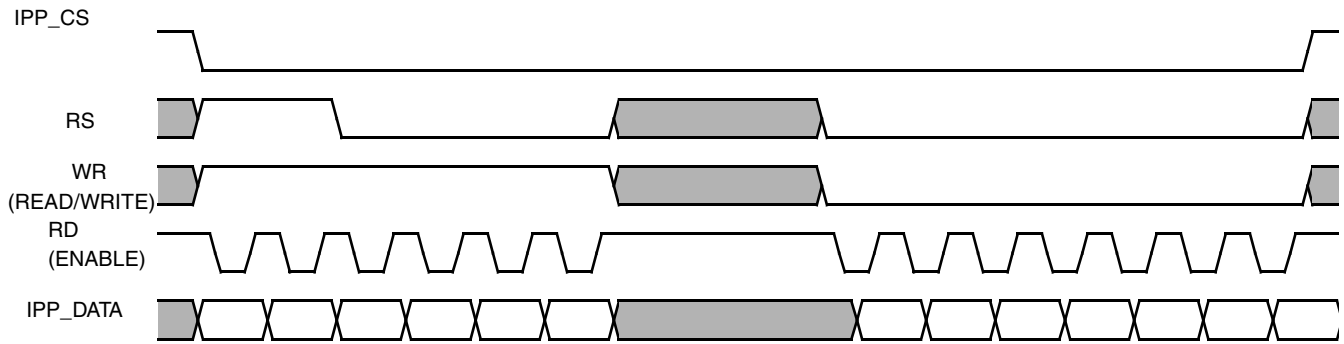

Burst access mode with sampling by ENABLE signal

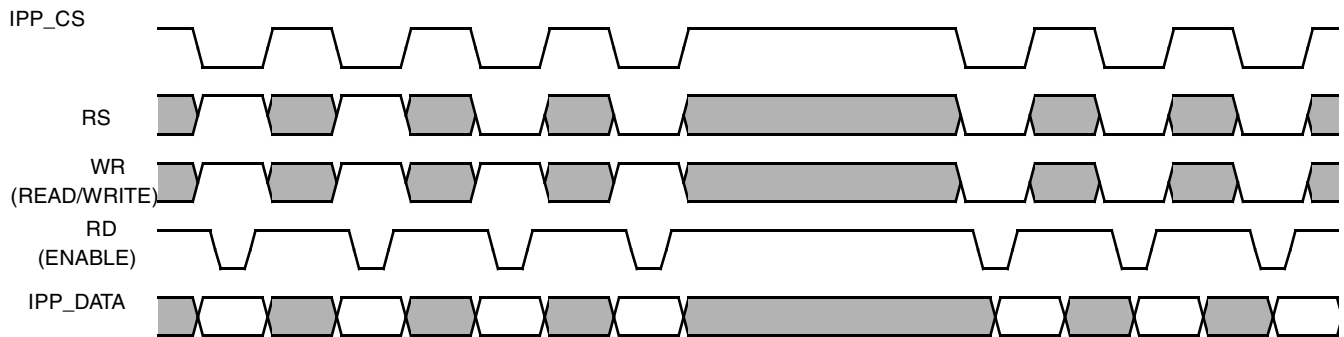

Single access mode (all control signals are not active for one display interface clock after each display access)

Figure 61. Asynchronous Parallel System 68k Interface (Type 2) Timing Diagram

Display operation can be performed with IPP_WAIT signal. The DI reacts to the incoming IPP_WAIT signal with 2 DI_CLK delay. The DI finishes a current access and a next access is postponed until IPP_WAIT release.

Figure 62 shows timing of the parallel interface with IPP_WAIT control.

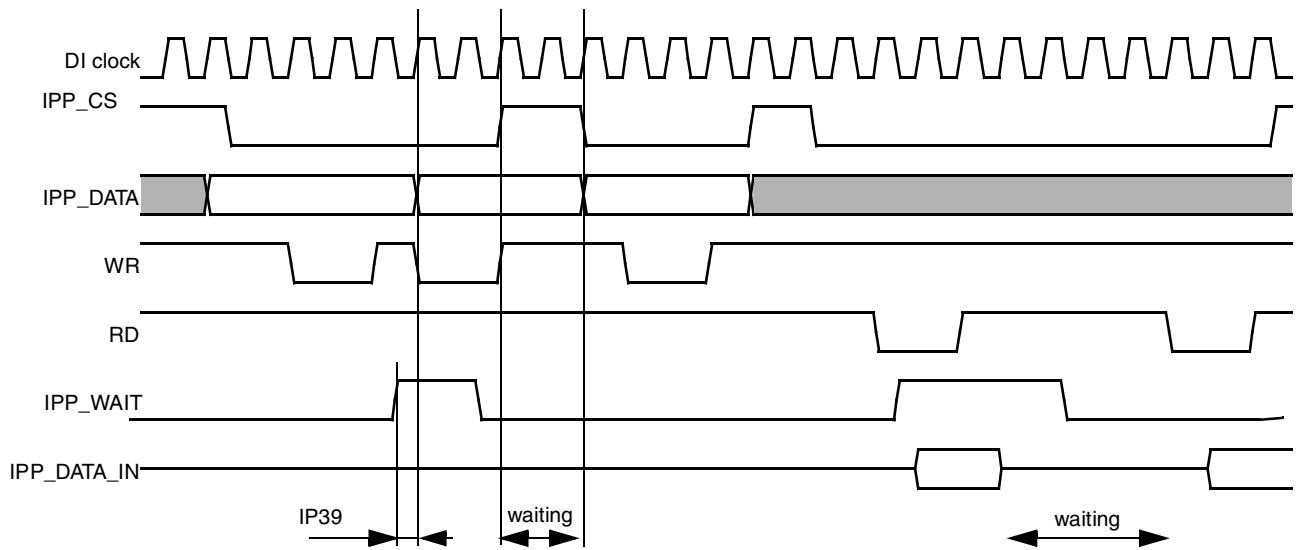

Figure 62. Parallel Interface Timing Diagram—Read Wait States

4.7.8.7.2 Asynchronous Parallel Interface Timing Parameters

Figure 63 depicts timing of asynchronous parallel interfaces based on the system 80 and system 68k interfaces. Table 84 shows the timing characteristics at display access level. Table 83 shows the timing characteristics at the logical level—from configuration perspective. All timing diagrams are based on active low control signals (signals polarity is controlled through the DI_DISP_SIG_POL register).

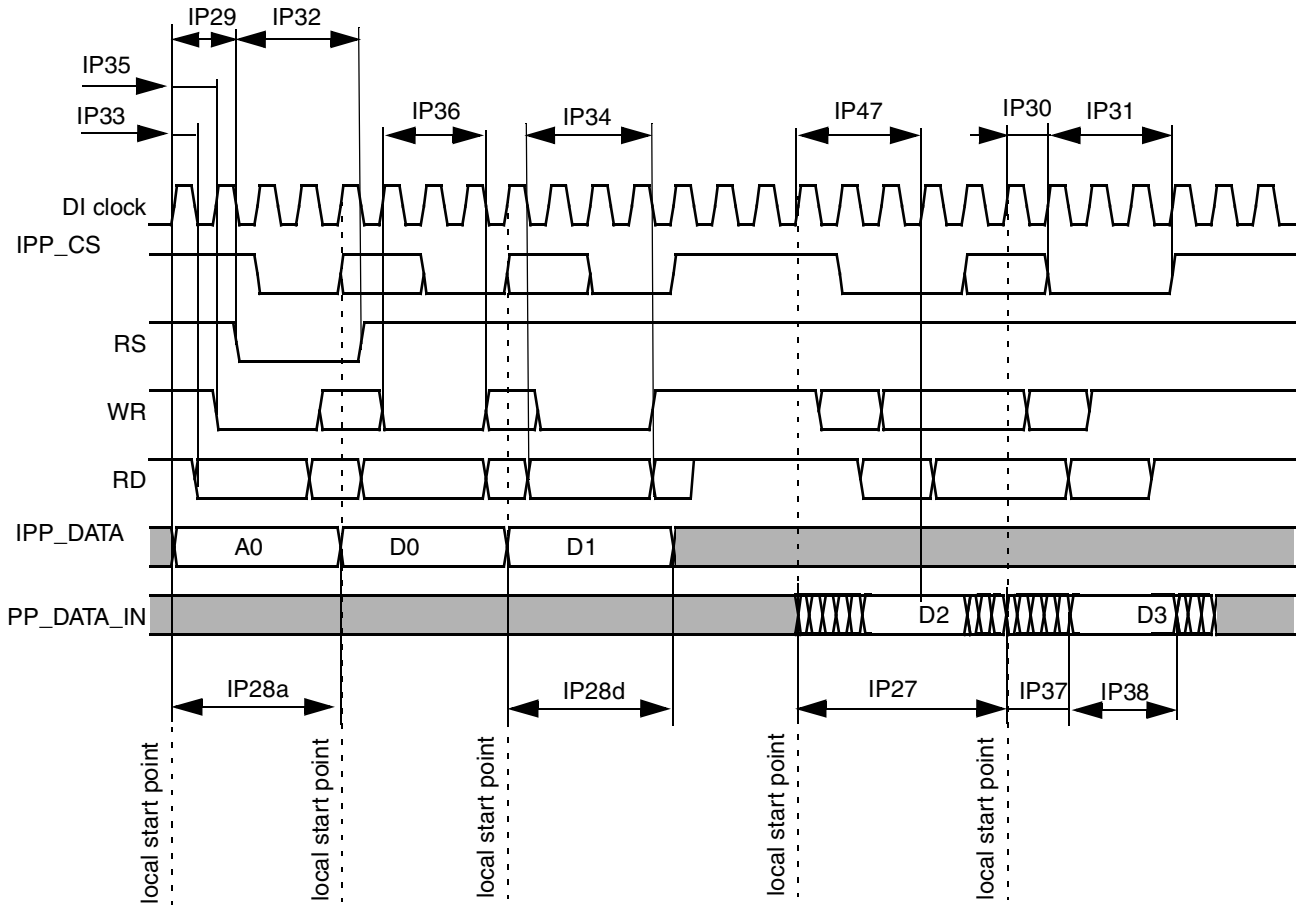

Figure 63. Asynchronous Parallel Interface Timing Diagram

Table 83. Asynchronous Display Interface Timing Parameters (Pixel Level)

| ID | Parameter | Symbol | Value | Description | Unit |
|-------|---------------------------------|--------|---------------|---|------|
| IP27 | Read system cycle time | Tcycr | ACCESS_SIZE_# | predefined value in DI REGISTER | ns |
| IP28a | Address Write system cycle time | Tcycwa | ACCESS_SIZE_# | predefined value in DI REGISTER | ns |
| IP28d | Data Write system cycle time | Tcycwd | ACCESS_SIZE_# | predefined value in DI REGISTER | ns |
| IP29 | RS start | Tdcrr | UP# | RS strobe switch, predefined value in DI REGISTER | ns |
| IP30 | CS start | Tdcsc | UP# | CS strobe switch, predefined value in DI REGISTER | ns |

Table 83. Asynchronous Display Interface Timing Parameters (Pixel Level) (continued)

| ID | Parameter | Symbol | Value | Description | Unit |
|------|--|--------|-------------------------------|--|------|
| IP31 | CS hold | Tdchc | DOWN# | CS strobe release, predefined value in DI REGISTER | — |
| IP32 | RS hold | Tdchrr | DOWN# | RS strobe release, predefined value in DI REGISTER | — |
| IP33 | Read start | Tdcsr | UP# | read strobe switch, predefined value in DI REGISTER | ns |
| IP34 | Read hold | Tdchr | DOWN# | read strobe release signal, predefined value in DI REGISTER | ns |
| IP35 | Write start | Tdcsw | UP# | write strobe switch, predefined value in DI REGISTER | ns |
| IP36 | Controls hold time for write | Tdchw | DOWN# | write strobe release, predefined value in DI REGISTER | ns |
| IP37 | Slave device data delay ¹ | Tracc | Delay of incoming data | Physical delay of display's data, defined from Read access local start point | ns |
| IP38 | Slave device data hold time ³ | Troh | Hold time of data on the buss | Time that display read data is valid in input bus | ns |
| IP47 | Read time point ¹³ | Tdrp | Data sampling point | Point of input data sampling by DI, predefined in DC Microcode | — |

¹This parameter is a requirement to the display connected to the IPU.

Table 84. Asynchronous Parallel Interface Timing Parameters (Access Level)

| ID | Parameter | Symbol | Min | Typ ¹ | Max | Unit |
|------|--|--------|----------------------|--|--|------|
| IP27 | Read system cycle time | Tcycr | Tdicpr-1.5 | Tdicpr ² | Tdicpr+1.5 | ns |
| IP28 | Write system cycle time | Tcyw | Tdicpw-1.5 | Tdicpw ³ | Tdicpw+1.5 | ns |
| IP29 | RS start | Tdcrr | Tdicurs-1.5 | Tdicurs | Tdicurs+1.5 | ns |
| IP30 | CS start | Tdcsc | Tdicucs-1.5 | Tdicur | Tdicucs+1.5 | ns |
| IP31 | CS hold | Tdchc | TdicdcsTdicucs-1.5 | Tdicdcs ⁴ -Tdicucs ⁵ | Tdicdcs-Tdicucs+1.5 | ns |
| IP32 | RS hold | Tdchrr | Tdicdrs-Tdicurs-1.5 | Tdicdrs ⁶ -Tdicurs ⁷ | Tdicdrs-Tdicurs+1.5 | ns |
| IP33 | Controls setup time for read | Tdcsr | Tdicur-1.5 | Tdicur | Tdicur+1.5 | ns |
| IP34 | Controls hold time for read | Tdchr | Tdicdr-Tdicur-1.5 | Tdicdr ⁸ -Tdicur ⁹ | Tdicdr-Tdicur+1.5 | ns |
| IP35 | Controls setup time for write | Tdcsw | Tdicuw-1.5 | Tdicuw | Tdicuw+1.5 | ns |
| IP36 | Controls hold time for write | Tdchw | Tdicdw-Tdicuw-1.5 | Tdicpw ¹⁰ -Tdicuw ¹¹ | Tdicdw-Tdicuw+1.5 | ns |
| IP37 | Slave device data delay ¹² | Tracc | 0 | — | Tdrp ¹³ -Tlbd ¹⁴ -Tdicur-1.5 | ns |
| IP38 | Slave device data hold time ⁸ | Troh | Tdrp-Tlbd-Tdicdr+1.5 | — | Tdicpr-Tdicdr-1.5 | ns |

Electrical Characteristics

Table 84. Asynchronous Parallel Interface Timing Parameters (Access Level) (continued)

| ID | Parameter | Symbol | Min | Typ ¹ | Max | Unit |
|------|-------------------------------|--------|----------|------------------|----------|------|
| IP39 | Setup time for wait signal | Tswait | — | — | — | — |
| IP47 | Read time point ¹³ | Tdrp | Tdrp-1.5 | Tdrp | Tdrp+1.5 | ns |

¹The exact conditions have not been finalized, but will likely match the current customer requirement for their specific display. These conditions may be chip specific.

²Display period value for read

$$T_{dicpr} = T_{DI_CLK} \times \text{ceil} \left[\frac{DI_ACCESS_SIZE_#}{DI_CLK_PERIOD} \right]$$

ACCESS_SIZE is predefined in REGISTER

³Display period value for write

$$T_{dicpw} = T_{DI_CLK} \times \text{ceil} \left[\frac{DI_ACCESS_SIZE_#}{DI_CLK_PERIOD} \right]$$

ACCESS_SIZE is predefined in REGISTER

⁴Display control down for CS

$$T_{dicdcs} = \frac{1}{2} \left(T_{DI_CLK} \times \text{ceil} \left[\frac{2 \times DISP_DOWN_#}{DI_CLK_PERIOD} \right] \right)$$

DISP_DOWN is predefined in REGISTER

⁵Display control up for CS

$$T_{dicucs} = \frac{1}{2} \left(T_{DI_CLK} \times \text{ceil} \left[\frac{2 \times DISP_UP_#}{DI_CLK_PERIOD} \right] \right)$$

DISP_UP is predefined in REGISTER

⁶Display control down for RS

$$T_{dicdrs} = \frac{1}{2} \left(T_{DI_CLK} \times \text{ceil} \left[\frac{2 \times DISP_DOWN_#}{DI_CLK_PERIOD} \right] \right)$$

DISP_DOWN is predefined in REGISTER

⁷Display control up for RS

$$T_{dicurs} = \frac{1}{2} \left(T_{DI_CLK} \times \text{ceil} \left[\frac{2 \times DISP_UP_#}{DI_CLK_PERIOD} \right] \right)$$

DISP_UP is predefined in REGISTER

⁸Display control down for read

$$T_{dicdr} = \frac{1}{2} \left(T_{DI_CLK} \times \text{ceil} \left[\frac{2 \times DISP_DOWN_#}{DI_CLK_PERIOD} \right] \right)$$

DISP_DOWN is predefined in REGISTER

⁹Display control up for read

$$T_{dicur} = \frac{1}{2} \left(T_{DI_CLK} \times \text{ceil} \left[\frac{2 \times \text{DISP_UP_}\#}{DI_CLK_PERIOD} \right] \right)$$

DISP_UP is predefined in REGISTER

¹⁰Display control down for read

$$T_{dicdrw} = \frac{1}{2} \left(T_{DI_CLK} \times \text{ceil} \left[\frac{2 \times \text{DISP_DOWN_}\#}{DI_CLK_PERIOD} \right] \right)$$

DISP_DOWN is predefined in REGISTER

¹¹Display control up for write

$$T_{dicuw} = \frac{1}{2} \left(T_{DI_CLK} \times \text{ceil} \left[\frac{2 \times \text{DISP_UP_}\#}{DI_CLK_PERIOD} \right] \right)$$

DISP_UP is predefined in REGISTER

¹²This parameter is a requirement to the display connected to the IPU

¹³Data read point

$$T_{drp} = T_{DI_CLK} \times \text{ceil} \left[\frac{\text{DISP}\#_{\text{READ_EN}}}{DI_CLK_PERIOD} \right]$$

Note: DISP#_READ_EN—operand of DC's MICROCDE READ command to sample incoming data

¹⁴Loop back delay T_{lbd} is the cumulative propagation delay of read controls and read data. It includes an IPU output delay, a chip-level output delay, board delays, a chip-level input delay, an IPU input delay. This value is chip specific.

4.7.8.8 Standard Serial Interfaces

The IPU supports the following types of asynchronous serial interfaces:

1. 3-wire (with bidirectional data line).
2. 4-wire (with separate data input and output lines).
3. 5-wire type 1 (with sampling RS by the serial clock).
4. 5-wire type 2 (with sampling RS by the chip select signal).

The IPU has four independent outputs and one input. The port can be configured to provide 3, 4, or 5-wire interfaces.

Figure 64 depicts the timing diagram of the 3-wire serial interface. The timing diagrams correspond to active-low IPP#_CS signal and the straight polarity of the IPP_CLK signal.

For this interface, a bidirectional data line is used outside the chip. The IPU still uses separate input and output data lines (IPP_IND_DISPB_SD_D and IPP_DO_DISPB_SD_D). The I/O mux should provide

Electrical Characteristics

joining the internal data lines to the bidirectional external line according to the IPP_OBE_DISPB_SD_D signal provided by the IPU.

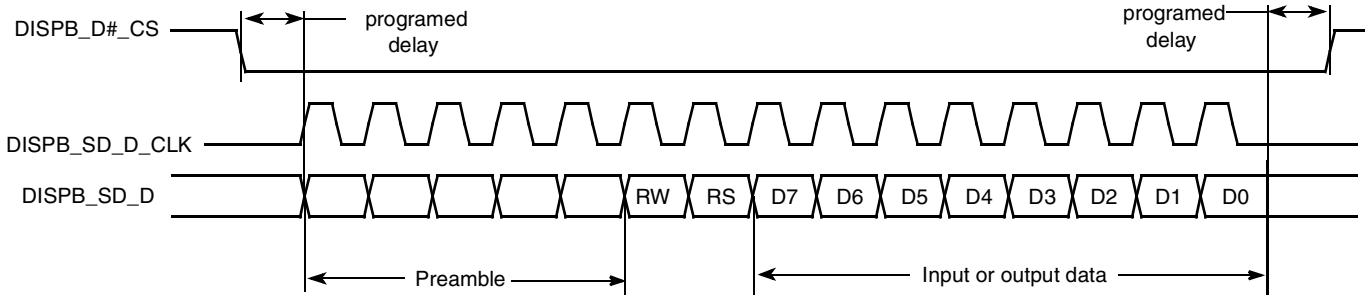

Figure 64. 3-Wire Serial Interface Timing Diagram

Figure 65 depicts timing diagram of the 4-wire serial interface. For this interface, there are separate input and output data lines both inside and outside the chip.

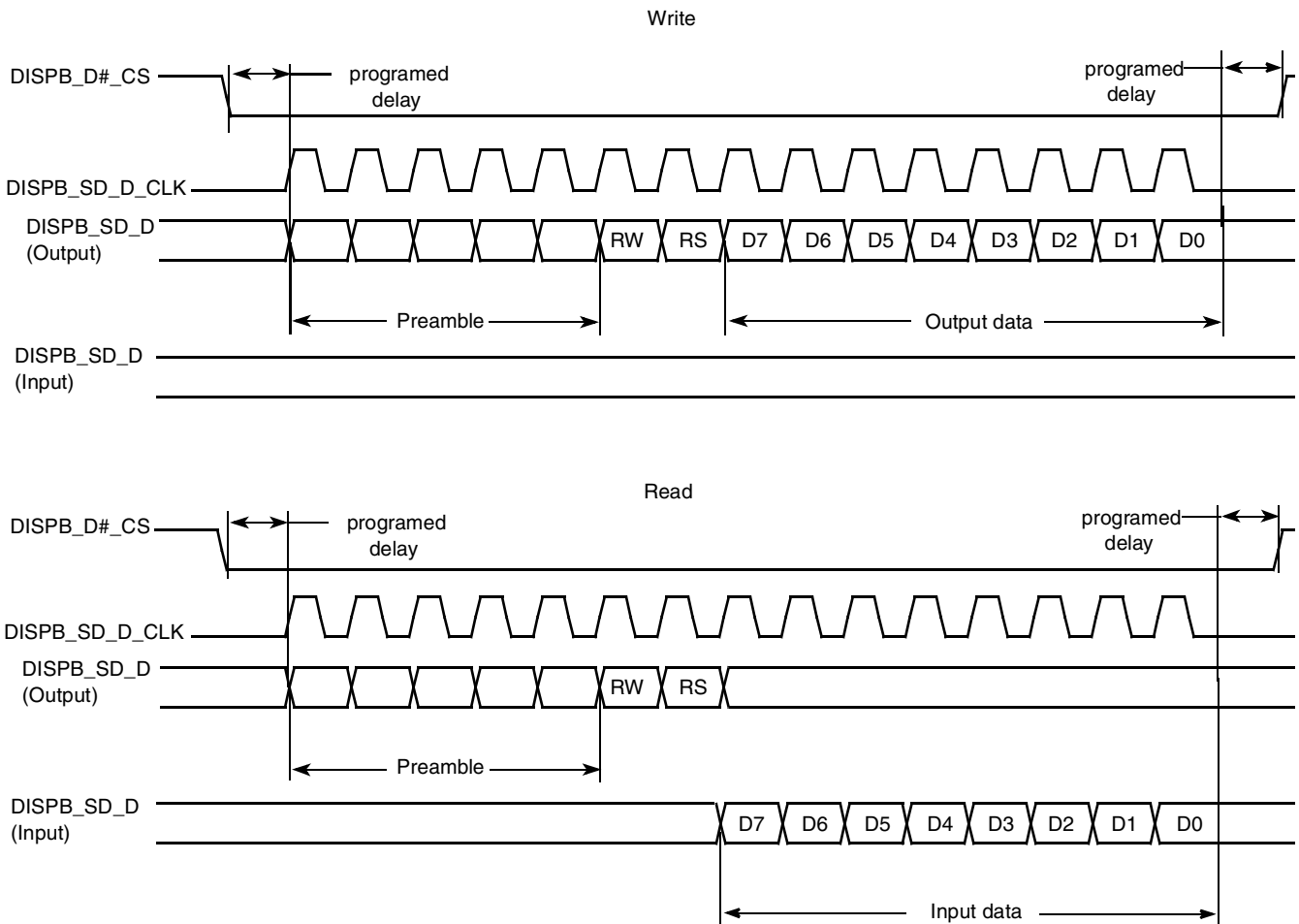

Figure 65. 4-Wire Serial Interface Timing Diagram

Figure 66 depicts timing of the 5-wire serial interface. For this interface, a separate RS line is added.

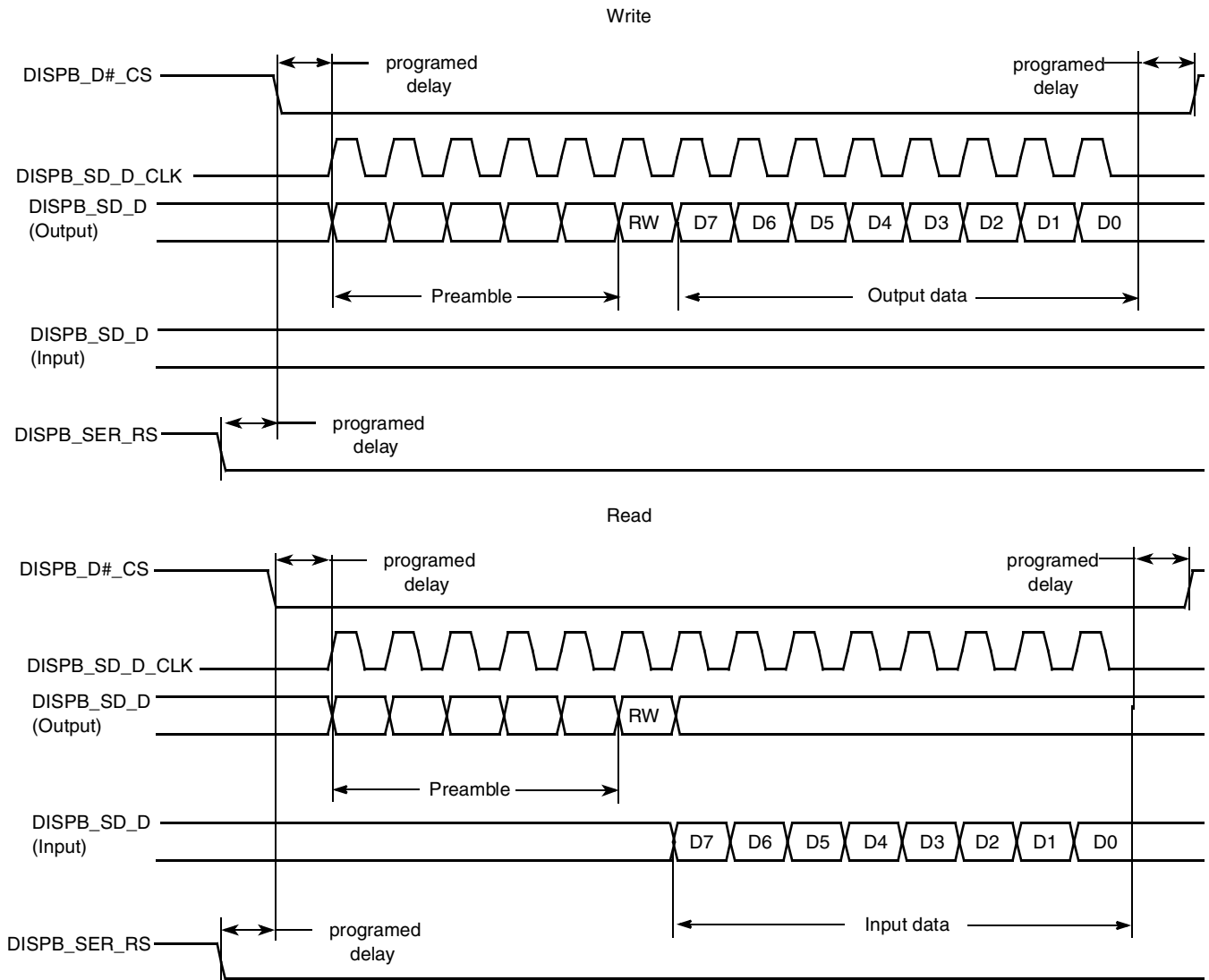

Figure 66. 5-Wire Serial Interface Timing Diagram

4.7.8.8.1 Asynchronous Serial Interface Timing Parameters

Figure 67 depicts timing of the serial interface. Table 85 shows timing characteristics at display access level.

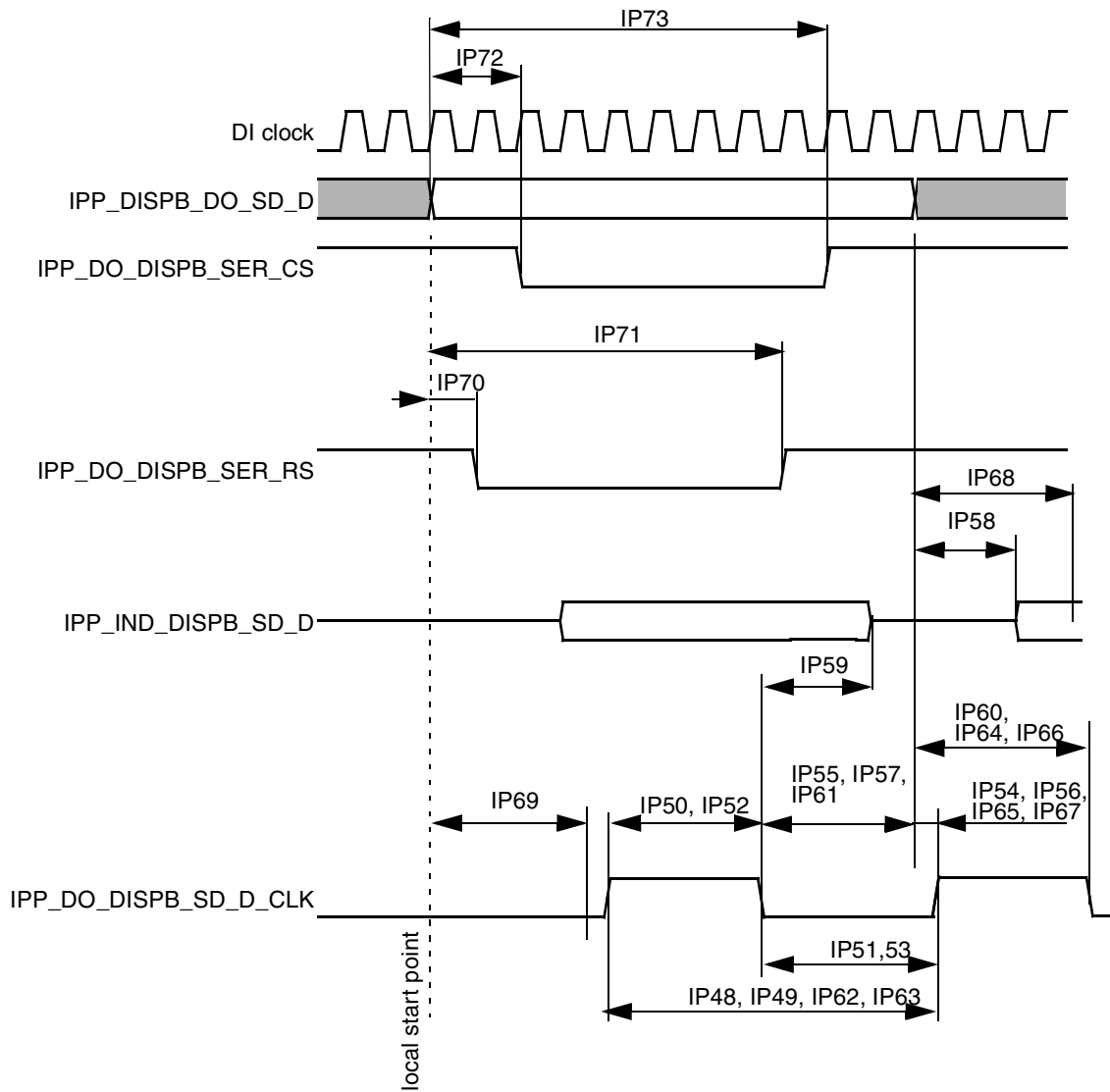

Figure 67. Asynchronous Serial Interface Timing Diagram

Table 85. Asynchronous Serial Interface Timing Characteristics (Access Level)

| ID | Parameter | Symbol | Min | Typ ¹ | Max | Unit |
|------|-----------------------------|--------|--------------------------|--|--------------------------|------|
| IP48 | Read system cycle time | Tcycr | Tdicpr-1.5 | Tdicpr ² | Tdicpr+1.5 | ns |
| IP49 | Write system cycle time | Tcycw | Tdicpw-1.5 | Tdicpw ³ | Tdicpw+1.5 | ns |
| IP50 | Read clock low pulse width | Trl | Tdicdr-Tdicur-1.5 | Tdicdr ⁴ -Tdicur ⁵ | Tdicdr-Tdicur+1.5 | ns |
| IP51 | Read clock high pulse width | Trh | Tdicpr-Tdicdr+Tdicur-1.5 | Tdicpr-Tdicdr+Tdicur | Tdicpr-Tdicdr+Tdicur+1.5 | ns |

Table 85. Asynchronous Serial Interface Timing Characteristics (Access Level) (continued)

| ID | Parameter | Symbol | Min | Typ ¹ | Max | Unit |
|------|--|---------|--------------------------|--|---|------|
| IP52 | Write clock low pulse width | Twl | Tdicdw-Tdicuw-1.5 | Tdicdw ⁶ -Tdicuw ⁷ | Tdicdw-Tdicuw+1.5 | ns |
| IP53 | Write clock high pulse width | Twh | Tdicpw-Tdicdw+Tdicuw-1.5 | Tdicpw-Tdicdw+Tdicuw | Tdicpw-Tdicdw+Tdicuw+1.5 | ns |
| IP54 | Controls setup time for read | Tdcsr | Tdicur-1.5 | Tdicur | — | ns |
| IP55 | Controls hold time for read | Tdchr | Tdicpr-Tdicdr-1.5 | Tdicpr-Tdicdr | — | ns |
| IP56 | Controls setup time for write | Tdcsw | Tdicuw-1.5 | Tdicuw | — | ns |
| IP57 | Controls hold time for write | Tdchw | Tdicpw-Tdicdw-1.5 | Tdicpw-Tdicdw | — | ns |
| IP58 | Slave device data delay ⁸ | Tracc | 0 | — | Tdrp ⁹ -Tlbd ¹⁰ -Tdicur-1.5 | ns |
| IP59 | Slave device data hold time ⁸ | Troh | Tdrp-Tlbd-Tdicdr+1.5 | — | Tdicpr-Tdicdr-1.5 | ns |
| IP60 | Write data setup time | Tds | Tdicdw-1.5 | Tdicdw | — | ns |
| IP61 | Write data hold time | Tdh | Tdicpw-Tdicdw-1.5 | Tdicpw-Tdicdw | — | ns |
| IP62 | Read period ² | Tdicpr | Tdicpr-1.5 | Tdicpr | Tdicpr+1.5 | ns |
| IP63 | Write period ³ | Tdicpw | Tdicpw-1.5 | Tdicpw | Tdicpw+1.5 | ns |
| IP64 | Read down time ⁴ | Tdicdr | Tdicdr-1.5 | Tdicdr | Tdicdr+1.5 | ns |
| IP65 | Read up time ⁵ | Tdicur | Tdicur-1.5 | Tdicur | Tdicur+1.5 | ns |
| IP66 | Write down time ⁶ | Tdicdw | Tdicdw-1.5 | Tdicdw | Tdicdw+1.5 | ns |
| IP67 | Write up time ⁷ | Tdicuw | Tdicuw-1.5 | Tdicuw | Tdicuw+1.5 | ns |
| IP68 | Read time point ⁹ | Tdrp | Tdrp-1.5 | Tdrp | Tdrp+1.5 | ns |
| IP69 | Clock offset ¹¹ | Toclk | Toclk-1.5 | Toclk | Toclk+1.5 | ns |
| IP70 | RS up time ¹² | Tdicurs | Tdicurs-1.5 | Tdicurs | Tdicurs+1.5 | ns |
| IP71 | RS down time ¹³ | Tdicdrs | Tdicdrs -1.5 | Tdicdrs | Tdicdrs+1.5 | ns |
| IP72 | CS up time ¹⁴ | Tdicucs | Tdicucs -1.5 | Tdicucs | Tdicucs+1.5 | ns |
| IP73 | CS down time ¹⁵ | Tdicdcs | Tdicdcs -1.5 | Tdicdcs | Tdicdcs+1.5 | ns |

¹The exact conditions have not been finalized, but will likely match the current customer requirement for their specific display. These conditions may be chip specific.

²Display interface clock period value for read

$$T_{dicpr} = T_{DI_CLK} \times \text{ceil} \left[\frac{DISP\#_IF_CLK_PER_RD}{DI_CLK_PERIOD} \right]$$

³Display interface clock period value for write

$$T_{dicpw} = T_{DI_CLK} \times \text{ceil} \left[\frac{DISP\#_IF_CLK_PER_WR}{DI_CLK_PERIOD} \right]$$

Electrical Characteristics

⁴Display interface clock down time for read

$$T_{dicdr} = \frac{1}{2} \left(T_{DI_CLK} \times \text{ceil} \left[\frac{2 \times \text{DISP_DOWN_}\#}{DI_CLK_PERIOD} \right] \right)$$

⁵Display interface clock up time for read

$$T_{dicur} = \frac{1}{2} \left(T_{DI_CLK} \times \text{ceil} \left[\frac{2 \times \text{DISP_UP_}\#}{DI_CLK_PERIOD} \right] \right)$$

⁶Display interface clock down time for write

$$T_{dicdw} = \frac{1}{2} \left(T_{DI_CLK} \times \text{ceil} \left[\frac{2 \times \text{DISP_DOWN_}\#}{DI_CLK_PERIOD} \right] \right)$$

⁷Display interface clock up time for write

$$T_{dicuw} = \frac{1}{2} \left(T_{DI_CLK} \times \text{ceil} \left[\frac{2 \times \text{DISP_UP_}\#}{DI_CLK_PERIOD} \right] \right)$$

⁸This parameter is a requirement to the display connected to the IPU

⁹Data read point

$$T_{drp} = T_{DI_CLK} \times \text{ceil} \left[\frac{\text{DISP_READ_EN}}{DI_CLK_PERIOD} \right]$$

DISP_RD_EN is predefined in REGISTER

¹⁰Loop back delay T_{lbd} is the cumulative propagation delay of read controls and read data. It includes an IPU output delay, a chip-level output delay, board delays, a chip-level input delay, an IPU input delay. This value is chip specific.

¹¹Display interface clock offset value

$$T_{oclk} = T_{DI_CLK} \times \text{ceil} \left[\frac{\text{DISP_CLK_OFFSET}}{DI_CLK_PERIOD} \right]$$

CLK_OFFSET is predefined in REGISTER

¹²Display RS up time

$$T_{dicurs} = T_{DI_CLK} \times \text{ceil} \left[\frac{\text{DISP_RS_UP_}\#}{DI_CLK_PERIOD} \right]$$

DISP_RS_UP is predefined in REGISTER

¹³Display RS down time

$$T_{dicdrs} = T_{DI_CLK} \times \text{ceil} \left[\frac{\text{DISP_RS_DOWN_}\#}{DI_CLK_PERIOD} \right]$$

DISP_RS_DOWN is predefined in REGISTER

¹⁴Display RS up time

$$T_{dicucs} = T_{DI_CLK} \times \text{ceil} \left[\frac{\text{DISP_CS_UP_}\#}{DI_CLK_PERIOD} \right]$$

DISP_CS_UP is predefined in REGISTER

¹⁵Display RS down time

$$T_{dcdc} = (T_{DI_CLK} \times \text{ceil}) \left[\frac{DISP_CS_DOWN_#}{DI_CLK_PERIOD} \right]$$

DISP_CS_DOWN is predefined in REGISTER.

4.7.9 1-Wire Timing Parameters

Figure 68 depicts the RPP timing and Table 86 lists the RPP timing parameters.

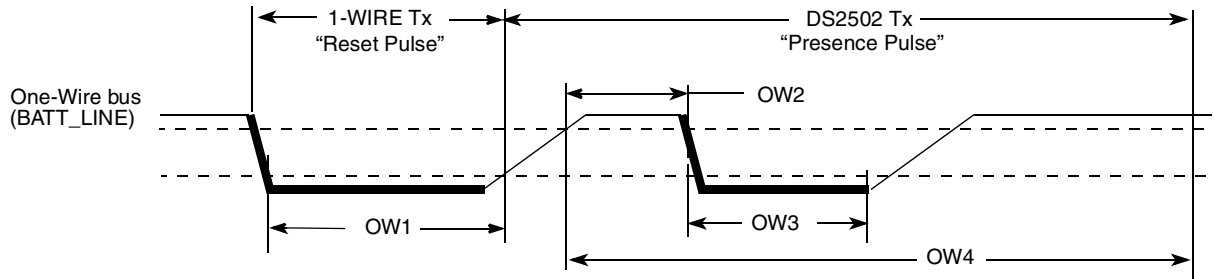

Figure 68. Reset and Presence Pulses (RPP) Timing Diagram

Table 86. RPP Sequence Delay Comparisons Timing Parameters

| ID | Parameters | Symbol | Min | Typ | Max | Unit |
|-----|----------------------|------------|-----|-----|-----|---------|
| OW1 | Reset Time Low | t_{RSTL} | 480 | 511 | — | μs |
| OW2 | Presence Detect High | t_{PDH} | 15 | — | 60 | μs |
| OW3 | Presence Detect Low | t_{PDL} | 60 | — | 240 | μs |
| OW4 | Reset Time High | t_{RSTH} | 480 | 512 | — | μs |

Figure 69 depicts Write 0 Sequence timing, and Table 87 lists the timing parameters.

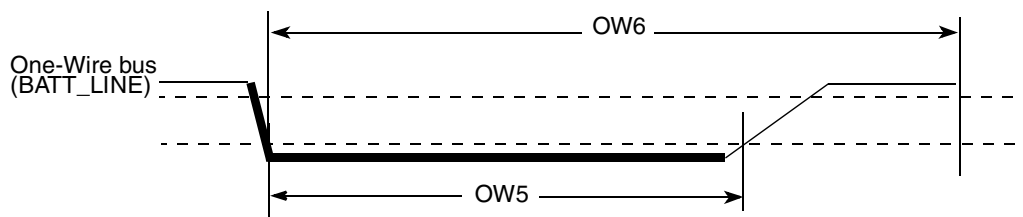

Figure 69. Write 0 Sequence Timing Diagram

Table 87. WR0 Sequence Timing Parameters

| ID | Parameter | Symbol | Min | Typ | Max | Unit |
|-----|------------------------|----------------|-----|-----|-----|---------|
| OW5 | Write 0 Low Time | t_{WR0_low} | 60 | 100 | 120 | μs |
| OW6 | Transmission Time Slot | t_{SLOT} | OW5 | 117 | 120 | μs |

Figure 70 depicts Write 1 Sequence timing, Figure 71 depicts the Read Sequence timing, and Table 88 lists the timing parameters.

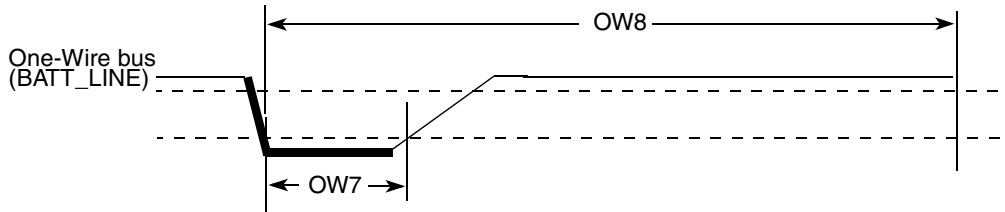

Figure 70. Write 1 Sequence Timing Diagram

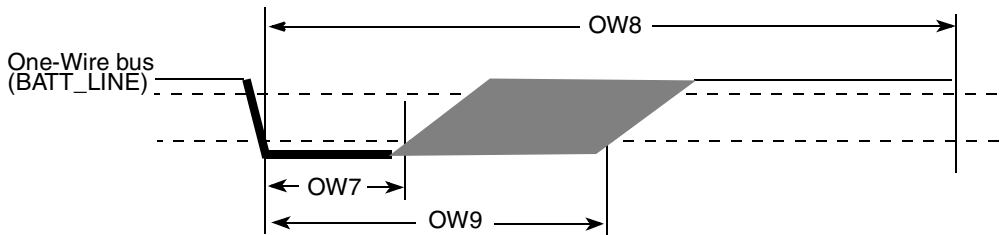

Figure 71. Read Sequence Timing Diagram

Table 88. WR1 /RD Timing Parameters

| ID | Parameter | Symbol | Min | Typ | Max | Unit |
|-----|------------------------|---------------|-----|-----|-----|---------|
| OW7 | Write /Read Low Time | t_{LOW1} | 1 | 5 | 15 | μs |
| OW8 | Transmission Time Slot | t_{SLOT} | 60 | 117 | 120 | μs |
| OW9 | Release Time | $t_{RELEASE}$ | 15 | — | 45 | μs |

4.7.10 Pulse Width Modulator (PWM) Timing Parameters

This section describes the electrical information of the PWM. The PWM can be programmed to select one of three clock signals as its source frequency. The selected clock signal is passed through a prescaler before being input to the counter. The output is available at the pulse-width modulator output (PWMO) external pin.

Figure 72 depicts the timing of the PWM, and Table 89 lists the PWM timing parameters.

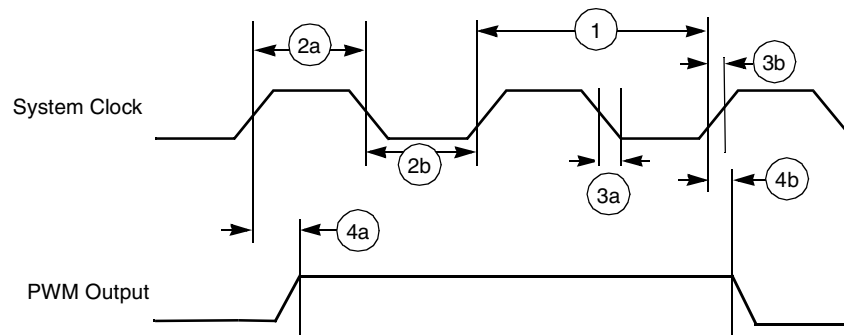

Figure 72. PWM Timing

Table 89. PWM Output Timing Parameter

| Ref. No. | Parameter | Min | Max | Unit |
|----------|-----------------------------------|-------|---------|------|
| 1 | System CLK frequency ¹ | 0 | ipg_clk | MHz |
| 2a | Clock high time | 12.29 | — | ns |
| 2b | Clock low time | 9.91 | — | ns |
| 3a | Clock fall time | — | 0.5 | ns |
| 3b | Clock rise time | — | 0.5 | ns |
| 4a | Output delay time | — | 9.37 | ns |
| 4b | Output setup time | 8.71 | — | ns |

¹ CL of PWMO = 30 pF

4.7.11 P-ATA Timing Parameters

This section describes the timing parameters of the Parallel ATA module which are compliant with ATA/ATAPI-5 specification.

Parallel ATA module can work on PIO/Multi-Word DMA/Ultra DMA transfer modes. Each transfer mode has different data transfer rate, Ultra DMA mode 4 data transfer rate is up to 66 Mbyte/s. Parallel ATA module interface consist of a total of 29 pins, Some pins act on different function in different transfer mode. There are different requirements of timing relationships among the function pins conform with ATA/ATAPI-5 specification and these requirements are configurable by the ATA module registers.

Electrical Characteristics

Table 90 and Figure 73 define the AC characteristics of all the P-ATA interface signals on all data transfer modes.

ATA Interface Signals

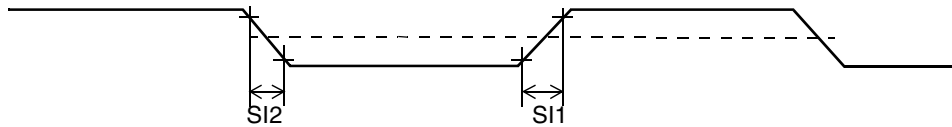

Figure 73. P-ATA Interface Signals Timing Diagram

Table 90. AC Characteristics of All Interface Signals

| ID | Parameter | Symbol | Min | Max | Unit |
|-----|---|------------|-----|------|------|
| SI1 | Rising edge slew rate for any signal on ATA interface. ¹ | S_{rise} | — | 1.25 | V/ns |
| SI2 | Falling edge slew rate for any signal on ATA interface (see note) | S_{fall} | — | 1.25 | V/ns |
| SI3 | Host interface signal capacitance at the host connector | C_{host} | — | 20 | pF |

¹ SRISE and SFALL shall meet this requirement when measured at the sender's connector from 10–90% of full signal amplitude with all capacitive loads from 15–40 pF where all signals have the same capacitive load value.

The user needs to use level shifters for 5.0 V compatibility on the ATA interface. The i.MX51 P-ATA interface is 3.3 V compatible.

The use of bus buffers introduces delay on the bus and introduces skew between signal lines. These factors make it difficult to operate the bus at the highest speed (UDMA-4) when bus buffers are used. If fast UDMA mode operation is needed, this may not be compatible with bus buffers.

Another area of attention is the slew rate limit imposed by the ATA specification on the ATA bus. According to this limit, any signal driven on the bus should have a slew rate between 0.4 and 1.2 V/ns with a 40 pF load. Not many vendors of bus buffers specify slew rate of the outgoing signals.

When bus buffers are used, the `ata_data` bus buffer is special. This is a bidirectional bus buffer, so a direction control signal is needed. This direction control signal is `ata_buffer_en`. When its high, the bus should drive from host to device. When its low, the bus should drive from device to host. Steering of the signal is such that contention on the host and device tri-state busses is always avoided.

In the timing equations, some timing parameters are used. These parameters depend on the implementation of the i.MX51 P-ATA interface on silicon, the bus buffer used, the cable delay and cable skew.

Table 91 shows ATA timing parameters.

Table 91. P-ATA Timing Parameters

| Name | Description | Value/ Contributing Factor ¹ |
|---------|--|--|
| T | Bus clock period (ipg_clk_ata) | Peripheral clock frequency |
| ti_ds | Set-up time ata_data to ata_iordy edge (UDMA-in only) UDMA0 UDMA1 UDMA2, UDMA3 UDMA4 | 15 ns 10 ns 7 ns 5 ns |
| ti_dh | Hold time ata_iordy edge to ata_data (UDMA-in only) UDMA0, UDMA1, UDMA2, UDMA3, UDMA4 | 5.0 ns |
| tco | Propagation delay bus clock L-to-H to ata_cs0, ata_cs1, ata_da2, ata_da1, ata_da0, ata_dior, ata_diow, ata_dmack, ata_data, ata_buffer_en | 12.0 ns |
| tsu | Set-up time ata_data to bus clock L-to-H | 8.5 ns |
| tsui | Set-up time ata_iordy to bus clock H-to-L | 8.5 ns |
| thi | Hold time ata_iordy to bus clock H to L | 2.5 ns |
| tskew1 | Max difference in propagation delay bus clock L-to-H to any of following signals ata_cs0, ata_cs1, ata_da2, ata_da1, ata_da0, ata_dior, ata_diow, ata_dmack, ata_data (write), ata_buffer_en | 7 ns |
| tskew2 | Max difference in buffer propagation delay for any of following signals ata_cs0, ata_cs1, ata_da2, ata_da1, ata_da0, ata_dior, ata_diow, ata_dmack, ata_data (write), ata_buffer_en | Transceiver |
| tskew3 | Max difference in buffer propagation delay for any of following signals ata_iordy, ata_data (read) | Transceiver |
| tbuf | Max buffer propagation delay | Transceiver |
| tcable1 | Cable propagation delay for ata_data | Cable |
| tcable2 | Cable propagation delay for control signals ata_dior, ata_diow, ata_iordy, ata_dmack | Cable |
| tskew4 | Max difference in cable propagation delay between ata_iordy and ata_data (read) | Cable |
| tskew5 | Max difference in cable propagation delay between (ata_dior, ata_diow, ata_dmack) and ata_cs0, ata_cs1, ata_da2, ata_da1, ata_da0, ata_data(write) | Cable |
| tskew6 | Max difference in cable propagation delay without accounting for ground bounce | Cable |

¹ Values provided where applicable.

4.7.11.1 PIO Mode Read Timing

Figure 74 shows timing for PIO read and Table 92 lists the timing parameters for PIO read.

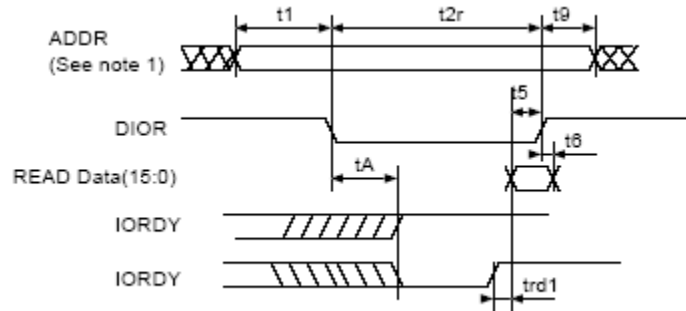

Figure 74. PIO Read Timing Diagram

Table 92. PIO Read Timing Parameters

| ATA Parameter | Parameter from Figure 74 | Value | Controlling Variable |
|---------------|--------------------------|---|-----------------------------|
| t1 | t1 | $t1 \text{ (min)} = \text{time_1} \times T - (\text{tskew1} + \text{tskew2} + \text{tskew5})$ | time_1 |
| t2 | t2r | $t2 \text{ min)} = \text{time_2r} \times T - (\text{tskew1} + \text{tskew2} + \text{tskew5})$ | time_2r |
| t9 | t9 | $t9 \text{ (min)} = \text{time_9} \times T - (\text{tskew1} + \text{tskew2} + \text{tskew6})$ | time_3 |
| t5 | t5 | $t5 \text{ (min)} = t_{co} + t_{su} + t_{buf} + t_{buf} + t_{cable1} + t_{cable2}$ | If not met, increase time_2 |
| t6 | t6 | 0 | — |
| tA | tA | $tA \text{ (min)} = (1.5 + \text{time_ax}) \times T - (t_{co} + t_{sui} + t_{cable2} + t_{cable2} + 2 \times t_{buf})$ | time_ax |
| trd | trd1 | $\text{trd1 (max)} = (-\text{trd}) + (\text{tskew3} + \text{tskew4})$ $\text{trd1 (min)} = (\text{time_pio_rdx} - 0.5) \times T - (t_{su} + t_{hi})$ $(\text{time_pio_rdx} - 0.5) \times T > t_{su} + t_{hi} + \text{tskew3} + \text{tskew4}$ | time_pio_rdx |
| t0 | — | $t0 \text{ (min)} = (\text{time_1} + \text{time_2} + \text{time_9}) \times T$ | time_1, time_2r, time_9 |

Figure 75 shows timing for PIO write and Table 93 lists the timing parameters for PIO write.

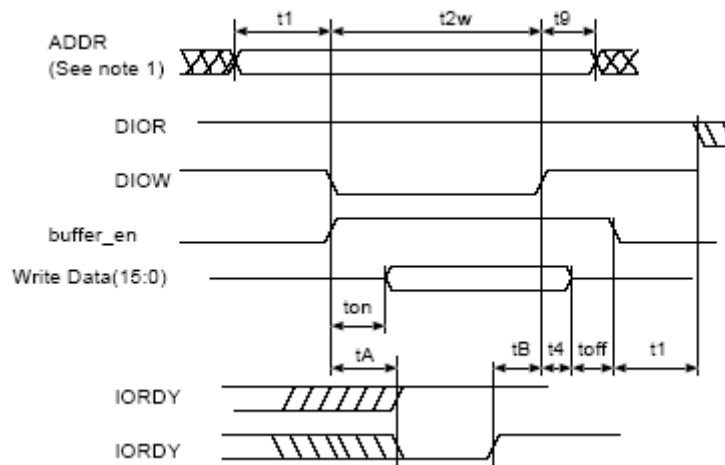

Figure 75. Multi-word DMA (MDMA) Timing

Table 93. PIO Write Timing Parameters

| ATA Parameter | Parameter from Figure 75 | Value | Controlling Variable |
|---------------|--------------------------|---|------------------------------|
| t1 | t1 | $t1 \text{ (min)} = \text{time_1} \times T - (\text{tskew1} + \text{tskew2} + \text{tskew5})$ | time_1 |
| t2 | t2w | $t2 \text{ (min)} = \text{time_2w} \times T - (\text{tskew1} + \text{tskew2} + \text{tskew5})$ | time_2w |
| t9 | t9 | $t9 \text{ (min)} = \text{time_9} \times T - (\text{tskew1} + \text{tskew2} + \text{tskew6})$ | time_9 |
| t3 | — | $t3 \text{ (min)} = (\text{time_2w} - \text{time_on}) \times T - (\text{tskew1} + \text{tskew2} + \text{tskew5})$ | If not met, increase time_2w |
| t4 | t4 | $t4 \text{ (min)} = \text{time_4} \times T - \text{tskew1}$ | time_4 |
| tA | tA | $tA = (1.5 + \text{time_ax}) \times T - (\text{tco} + \text{tsui} + \text{tcable2} + \text{tcable2} + 2 \times \text{tbuf})$ | time_ax |
| t0 | — | $t0 \text{ (min)} = (\text{time_1} + \text{time_2} + \text{time_9}) \times T$ | time_1, time_2r, time_9 |
| — | — | Avoid bus contention when switching buffer on by making ton long enough | — |
| — | — | Avoid bus contention when switching buffer off by making toff long enough | — |

Electrical Characteristics

Figure 76 shows timing for MDMA read, Figure 77 shows timing for MDMA write, and Table 94 lists the timing parameters for MDMA read and write.

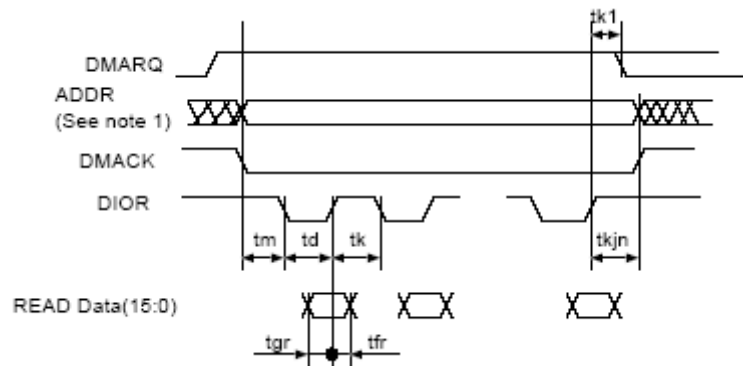

Figure 76. MDMA Read Timing Diagram

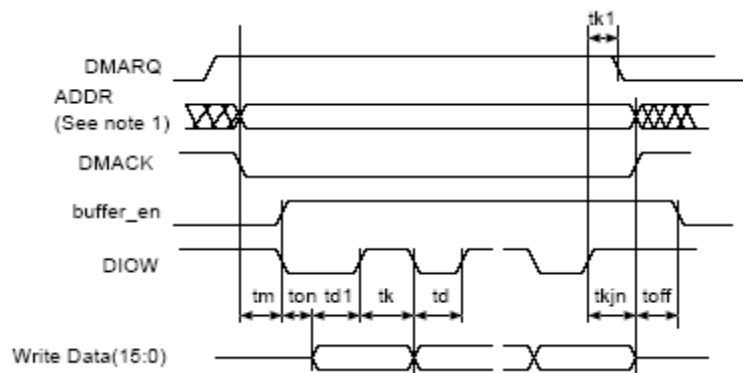

Figure 77. MDMA Write Timing Diagram

Table 94. MDMA Read and Write Timing Parameters

| ATA Parameter | Parameter from Figure 76, Figure 77 | Value | Controlling Variable |
|---------------|-------------------------------------|--|----------------------|
| tm, ti | tm | $t_m (\text{min}) = t_i (\text{min}) = \text{time}_m \times T - (\text{tskew1} + \text{tskew2} + \text{tskew5})$ | time_m |
| td | td, td1 | $td1.(\text{min}) = td (\text{min}) = \text{time}_d \times T - (\text{tskew1} + \text{tskew2} + \text{tskew6})$ | time_d |
| tk | tk | $tk.(\text{min}) = \text{time}_k \times T - (\text{tskew1} + \text{tskew2} + \text{tskew6})$ | time_k |
| t0 | — | $t0 (\text{min}) = (\text{time}_d + \text{time}_k) \times T$ | time_d, time_k |
| tg(read) | tgr | $tgr (\text{min-read}) = t_{co} + t_{su} + t_{buf} + t_{buf} + t_{cable1} + t_{cable2}$ $tgr.(\text{min-drive}) = td - t_{e}(\text{drive})$ | time_d |
| tf(read) | tfr | $tfr (\text{min-drive}) = 0$ | — |
| tg(write) | — | $tg (\text{min-write}) = \text{time}_d \times T - (\text{tskew1} + \text{tskew2} + \text{tskew5})$ | time_d |
| tf(write) | — | $tf (\text{min-write}) = \text{time}_k \times T - (\text{tskew1} + \text{tskew2} + \text{tskew6})$ | time_k |
| tL | — | $tL (\text{max}) = (\text{time}_d + \text{time}_k - 2) \times T - (t_{su} + t_{co} + 2 \times t_{buf} + 2 \times t_{cable2})$ | time_d, time_k |

Table 94. MDMA Read and Write Timing Parameters (continued)

| ATA Parameter | Parameter from Figure 76, Figure 77 | Value | Controlling Variable |
|---------------|-------------------------------------|---|----------------------|
| tn, tj | tkjn | $tn = tj = tkjn = (\max(\text{time_k}, \text{time_jn}) \times T - (\text{tskew1} + \text{tskew2} + \text{tskew6}))$ | time_jn |
| — | ton toff | ton = time_on × T – tskew1 toff = time_off × T – tskew1 | — |

4.7.11.2 Ultra DMA (UDMA) Input Timing

Figure 78 shows timing when the UDMA in transfer starts, Figure 79 shows timing when the UDMA in host terminates transfer, Figure 80 shows timing when the UDMA in device terminates transfer, and Table 95 lists the timing parameters for UDMA in burst.

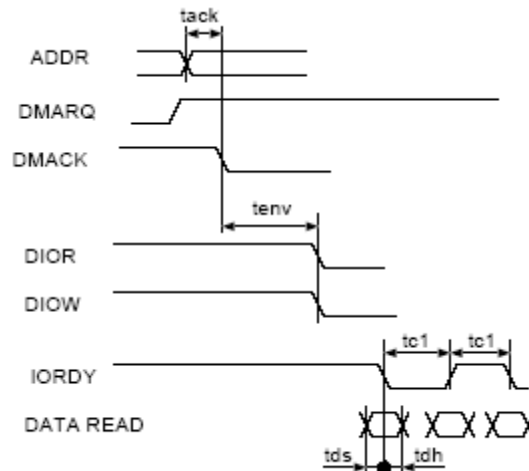

Figure 78. UDMA In Transfer Starts Timing Diagram

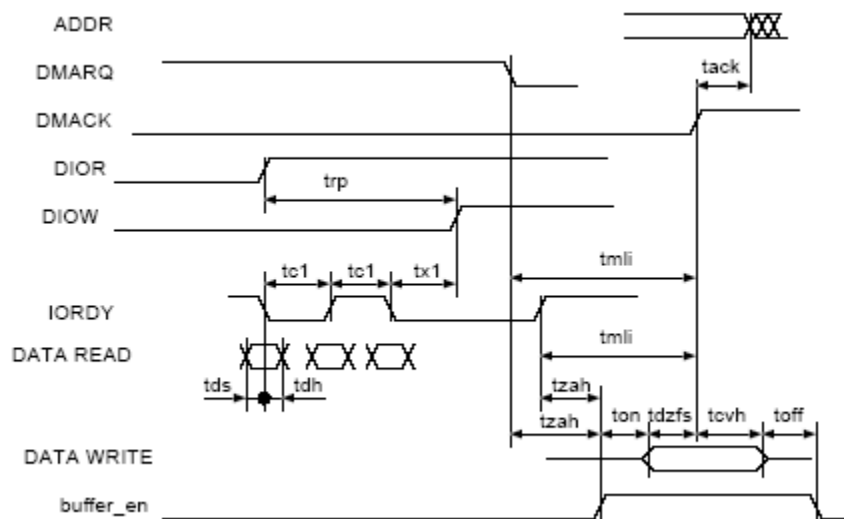

Figure 79. UDMA In Host Terminates Transfer Timing Diagram

Electrical Characteristics

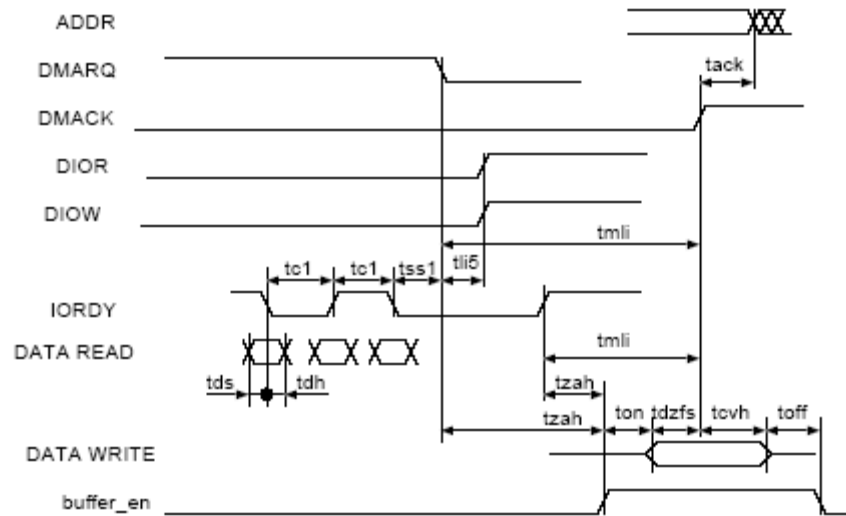

Figure 80. UDMA In Device Terminates Transfer Timing Diagram

Table 95. UDMA In Burst Timing Parameters

| ATA Parameter | Parameter from Figure 78, Figure 79, Figure 80 | Description | Controlling Variable |
|---------------|--|--|---|
| tack | tack | $tack (min) = (time_ack \times T) - (tskew1 + tskew2)$ | time_ack |
| tenv | tenv | $tenv (min) = (time_env \times T) - (tskew1 + tskew2)$ $tenv (max) = (time_env \times T) + (tskew1 + tskew2)$ | time_env |
| tds | tds1 | $tds - (tskew3) - ti_ds > 0$ | tskew3, ti_ds, ti_dh should be low enough |
| tdh | tdh1 | $tdh - (tskew3) - ti_dh > 0$ | |
| tcyc | tc1 | $(tcyc - tskew) > T$ | T big enough |
| trp | trp | $trp (min) = time_rp \times T - (tskew1 + tskew2 + tskew6)$ | time_rp |
| — | tx1 ¹ | $(time_rp \times T) - (tco + tsu + 3T + 2 \times tbuf + 2 \times tcable2) > trfs (drive)$ | time_rp |
| tmli | tmli1 | $tmli1 (min) = (time_mlix + 0.4) \times T$ | time_mlix |
| tzah | tzah | $tzah (min) = (time_zah + 0.4) \times T$ | time_zah |
| tdzfs | tdzfs | $tdzfs = (time_dzfs \times T) - (tskew1 + tskew2)$ | time_dzfs |
| tcvh | tcvh | $tcvh = (time_cvh \times T) - (tskew1 + tskew2)$ | time_cvh |
| — | ton toff ² | $ton = time_on \times T - tskew1$ $toff = time_off \times T - tskew1$ | — |

¹ There is a special timing requirement in the ATA host that requires the internal DIOW to go only high 3 clocks after the last active edge on the DSTROBE signal. The equation given on this line tries to capture this constraint.

² Make ton and toff big enough to avoid bus contention.

4.7.11.3 UDMA Output Timing

Figure 81 shows timing when the UDMA out transfer starts, Figure 82 shows timing when the UDMA out host terminates transfer, Figure 83 shows timing when the UDMA out device terminates transfer, and Table 96 lists the timing parameters for UDMA out burst.

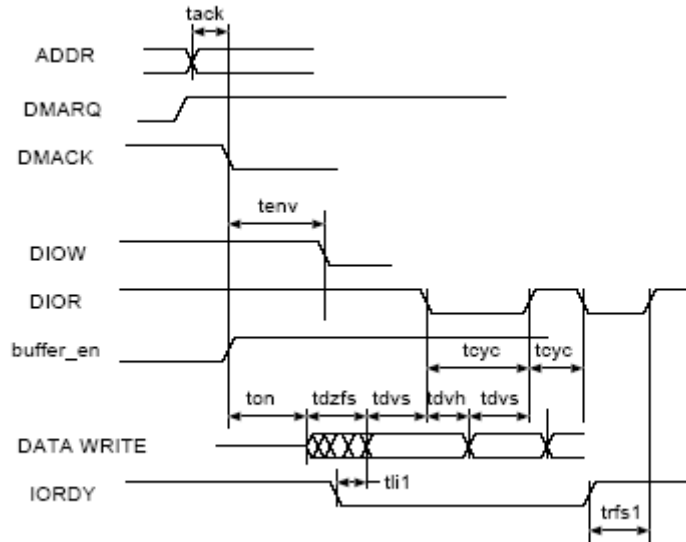

Figure 81. UDMA Out Transfer Starts Timing Diagram

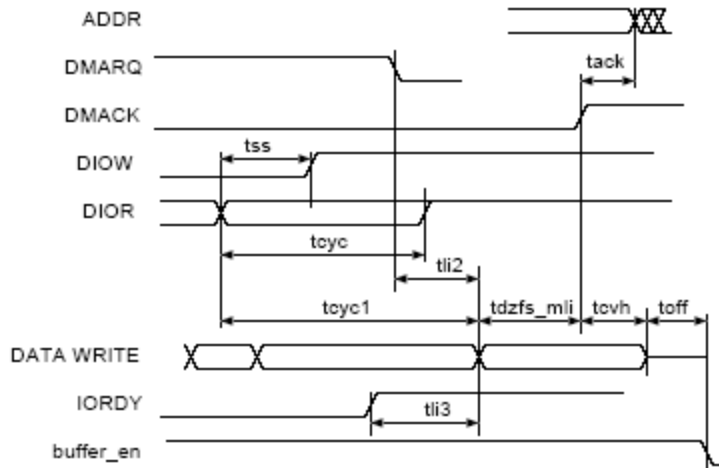

Figure 82. UDMA Out Host Terminates Transfer Timing Diagram

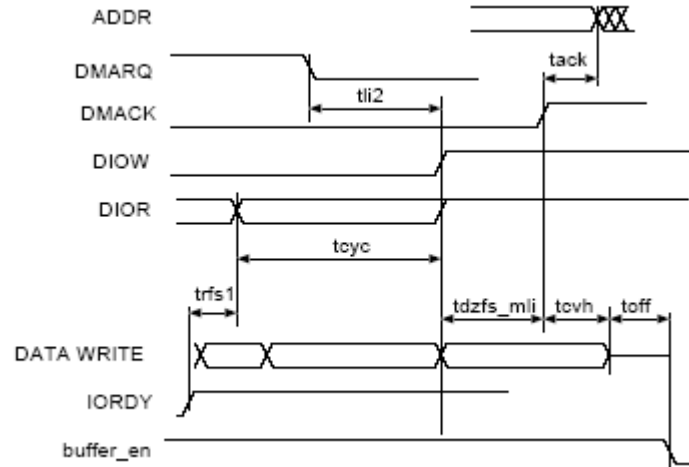

Figure 83. UDMA Out Device Terminates Transfer Timing Diagram

Table 96. UDMA Out Burst Timing Parameters

| ATA Parameter | Parameter from Figure 81, Figure 82, Figure 83 | Value | Controlling Variable |
|---------------|--|--|----------------------|
| tack | tack | $tack (min) = (time_ack \times T) - (tskew1 + tskew2)$ | time_ack |
| tenv | tenv | $tenv (min) = (time_env \times T) - (tskew1 + tskew2)$ $tenv (max) = (time_env \times T) + (tskew1 + tskew2)$ | time_env |
| tdvs | tdvs | $tdvs = (time_dvs \times T) - (tskew1 + tskew2)$ | time_dvs |
| tdvh | tdvh | $tdvs = (time_dvh \times T) - (tskew1 + tskew2)$ | time_dvh |
| tcyc | tcyc | $tcyc = time_cyc \times T - (tskew1 + tskew2)$ | time_cyc |
| t2cyc | — | $t2cyc = time_cyc \times 2 \times T$ | time_cyc |
| trfs1 | trfs | $trfs = 1.6 \times T + tsui + tco + tbuf + tbuf$ | — |
| — | tdzfs | $tdzfs = time_dzfs \times T - (tskew1)$ | time_dzfs |
| tss | tss | $tss = time_ss \times T - (tskew1 + tskew2)$ | time_ss |
| tmli | tdzfs_mli | $tdzfs_mli = \max (time_dzfs, time_mli) \times T - (tskew1 + tskew2)$ | — |
| tli | tli1 | $tli1 > 0$ | — |
| tli | tli2 | $tli2 > 0$ | — |
| tli | tli3 | $tli3 > 0$ | — |
| tcvh | tcvh | $tcvh = (time_cvh \times T) - (tskew1 + tskew2)$ | time_cvh |
| — | ton toff | $ton = time_on \times T - tskew1$ $toff = time_off \times T - tskew1$ | — |

4.7.12 SIM (Subscriber Identification Module) Timing

This section describes the electrical parameters of the SIM module. Each SIM module interface consists of 12 signals (two separate ports each containing six signals). Typically a port uses five signals.

The interface is designed to be used with synchronous SIM cards meaning the SIM module provides the clock used by the SIM card. The clock frequency is typically 372 times the Tx/Rx data rate, however the SIM module can work with CLK frequencies of 16 times the Tx/Rx data rate.

There is no timing relationship between the clock and the data. The clock that the SIM module provides to the SIM card is used by the SIM card to recover the clock from the data in the same manner as standard UART data exchanges. All six signals (5 for bi-directional Tx/Rx) of the SIM module are asynchronous to each other.

There are no required timing relationships between signals in normal mode. The SIM card is initiated by the interface device; the SIM card responds with Answer to Reset. Although the SIM interface has no defined requirements, the ISO-7816 defines reset and power-down sequences. (For detailed information, see ISO-7816.)

Table 97 defines the general timing requirements for the SIM interface.

Table 97. SIM Timing Parameters, High Drive Strength

| ID | Parameter | Symbol | Min | Max | Unit |
|-----|--|--------------------|------|-----------------------------|------|
| SI1 | SIM Clock Frequency (SIMx_CLKy) ¹ , | S _{freq} | 0.01 | 25 | MHz |
| SI2 | SIM Clock Rise Time (SIMx_CLKy) ² | S _{rise} | — | 0.09×(1/S _{freq}) | ns |
| SI3 | SIM Clock Fall Time (SIMx_CLKy) ³ | S _{fall} | — | 0.09×(1/S _{freq}) | ns |
| SI4 | SIM Input Transition Time (SIMx_DATAy_RX_TX, SIMx_SIMPDy) | S _{trans} | 10 | 25 | ns |
| SI5 | SIM I/O Rise Time / Fall Time(SIMx_DATAy_RX_TX) ⁴ | Tr/Tf | — | 1 | μs |
| SI6 | SIM RST Rise Time / Fall Time(SIMx_RSTy) ⁵ | Tr/Tf | — | 1 | μs |

¹ 50% duty cycle clock

² With C = 50 pF

³ With C = 50 pF

⁴ With C_{in} = 30 pF, C_{out} = 30 pF

⁵ With C_{in} = 30 pF

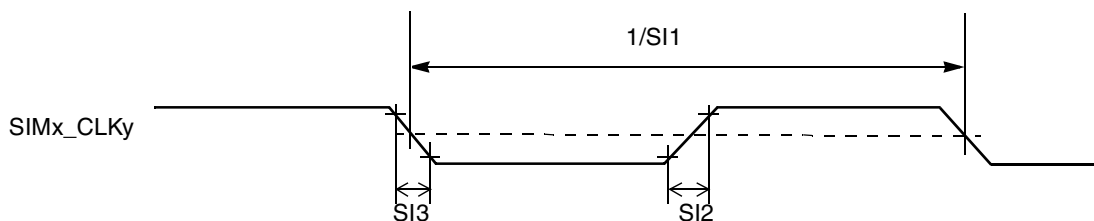

Figure 84. SIM Clock Timing Diagram

4.7.12.1 Reset Sequence

4.7.12.1.1 Cards with internal reset

The sequence of reset for this kind of SIM Cards is as follows (see [Figure 85](#)):

- After power up, the clock signal is enabled on SIMx_CLKy (time T0)
- After 200 clock cycles, RX must be high.
- The card must send a response on RX acknowledging the reset between 400 and 40000 clock cycles after T0.

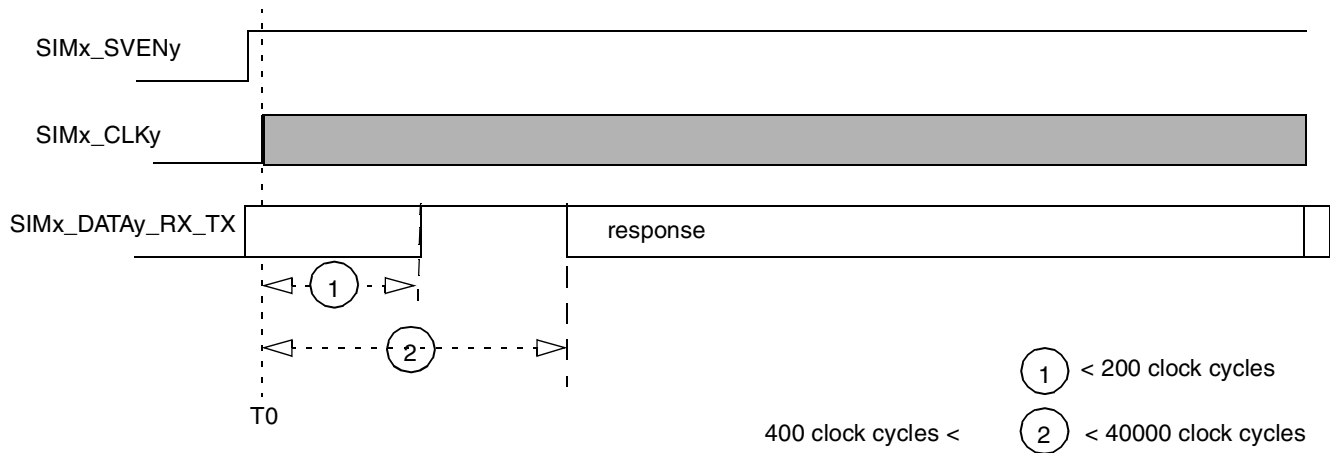

Figure 85. Internal-Reset Card Reset Sequence

4.7.12.1.2 Cards with Active Low Reset

The sequence of reset for this kind of card is as follows (see [Figure 86](#)):

- After power-up, the clock signal is enabled on SIMx_CLKy (time T0)
- After 200 clock cycles, SIMx_DATAy_RX_TX must be high.
- SIMx_RSTy must remain Low for at least 40000 clock cycles after T0 (no response is to be received on RX during those 40000 clock cycles)
- SIMx_RSTy is set High (time T1)
- SIMx_RSTy must remain High for at least 40000 clock cycles after T1 and a response must be received on SIMx_DATAy_RX_TX between 400 and 40000 clock cycles after T1.

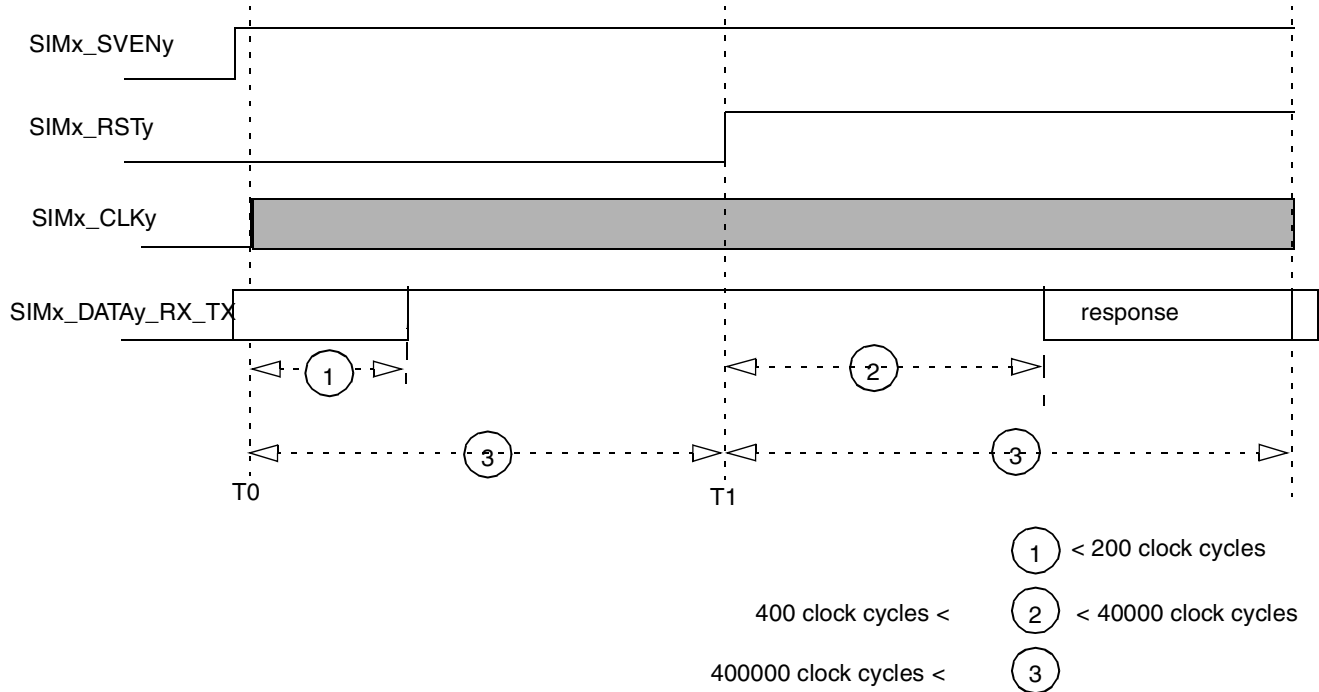

Figure 86. Active-Low-Reset Cards Reset Sequence

4.7.12.2 Power Down Sequence

Power down sequence for SIM interface is as follows:

- SIMx_SIMPDy port detects the removal of the SIM Card
- SIMx_RSTy goes Low
- SIMx_CLKy goes Low
- SIMx_DATAy_RX_TX goes Low
- SIMx_SVENy goes Low

Electrical Characteristics

Each of these steps is done in one CKIL period (usually 32 kHz). Power-down can be started because of a SIM Card removal detection or launched by the processor. Figure 87 and Table 98 shows the usual timing requirements for this sequence, with F_{ckil} = CKIL frequency value.

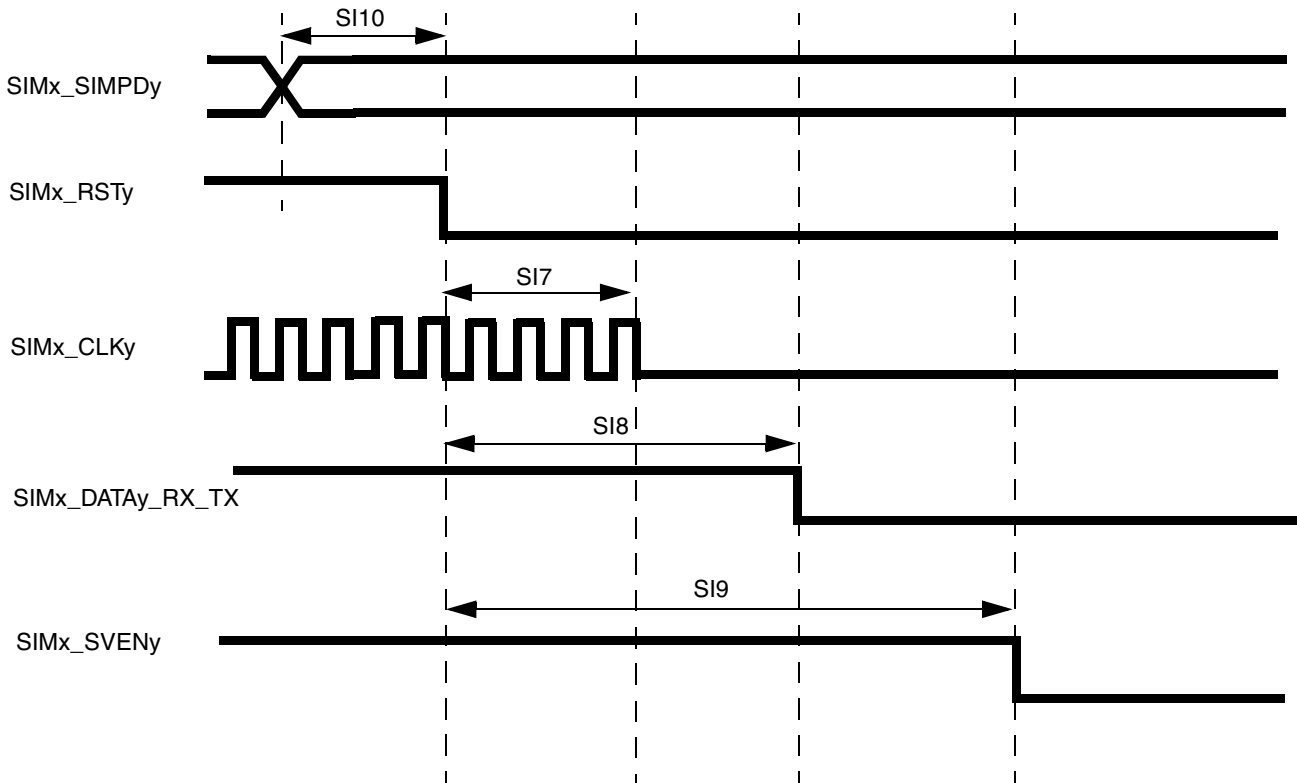

Figure 87. SmartCard Interface Power Down AC Timing

Table 98. Timing Requirements for Power Down Sequence

| ID | Parameter | Symbol | Min | Max | Unit |
|------|--------------------------------------|---------------|-------------------------|-------------------------|------|
| SI7 | SIM reset to SIM clock stop | $S_{rst2clk}$ | $0.9 \times 1/F_{ckil}$ | $1.1 \times 1/F_{ckil}$ | ns |
| SI8 | SIM reset to SIM TX data low | $S_{rst2dat}$ | $1.8 \times 1/F_{ckil}$ | $2.2 \times 1/F_{ckil}$ | ns |
| SI9 | SIM reset to SIM voltage enable low | $S_{rst2ven}$ | $2.7 \times 1/F_{ckil}$ | $3.3 \times 1/F_{ckil}$ | ns |
| SI10 | SIM presence detect to SIM reset low | S_{pd2rst} | $0.9 \times 1/F_{ckil}$ | $1.1 \times 1/F_{ckil}$ | ns |

4.7.13 SCAN JTAG Controller (SJC) Timing Parameters

Figure 88 depicts the SJC test clock input timing. Figure 89 depicts the SJC boundary scan timing. Figure 91 depicts the TRST timing with respect to TCK. Figure 90 depicts the SJC test access port. Signal parameters are listed in Table 99.

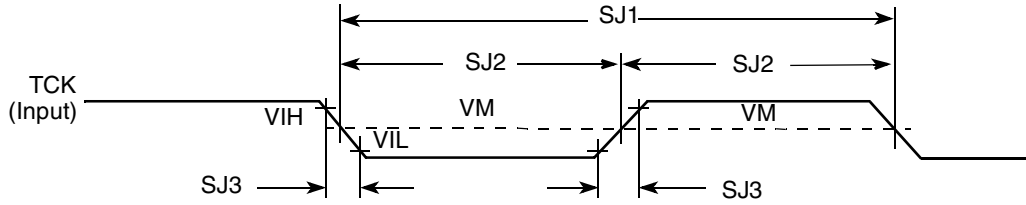

Figure 88. Test Clock Input Timing Diagram

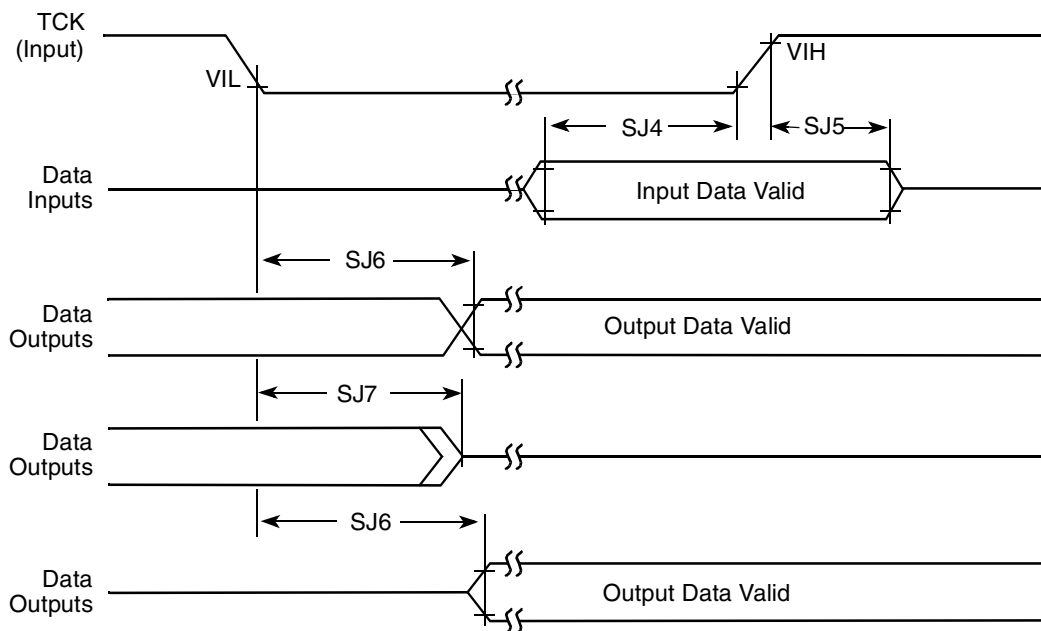

Figure 89. Boundary Scan (JTAG) Timing Diagram

Electrical Characteristics

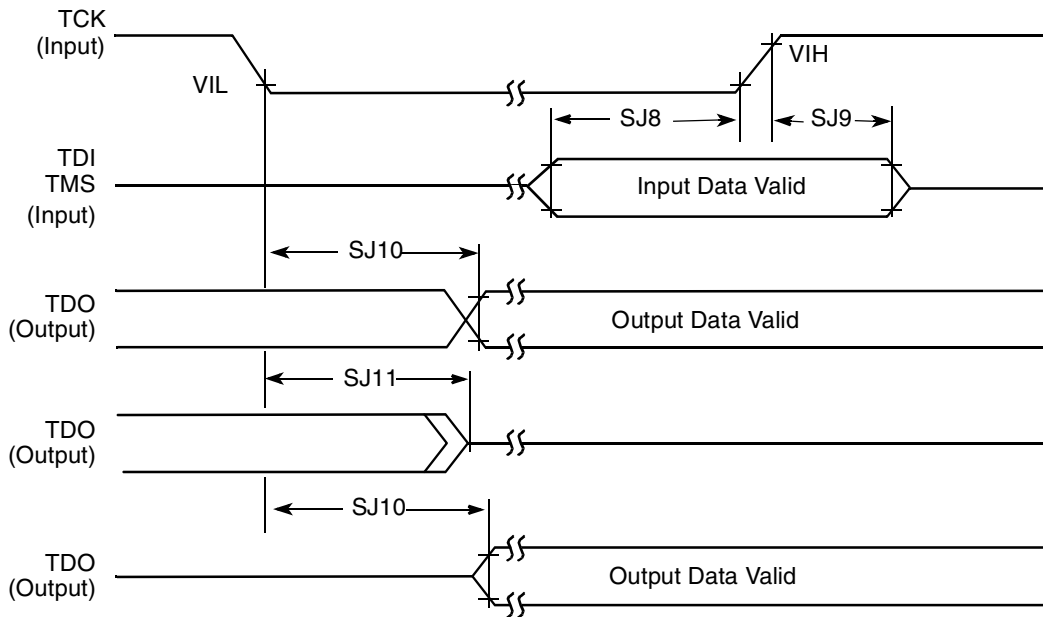

Figure 90. Test Access Port Timing Diagram

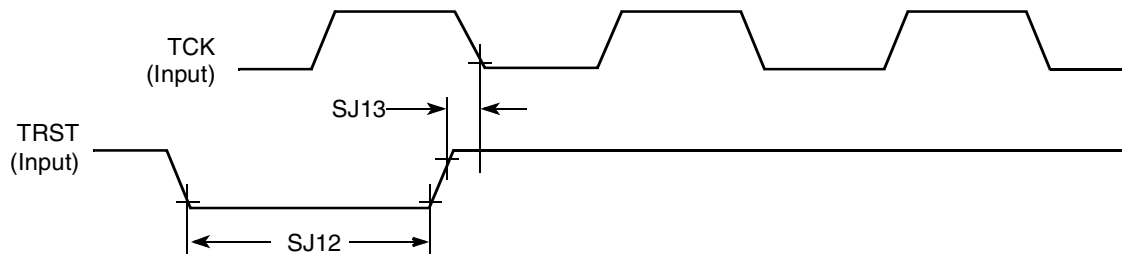

Figure 91. $\overline{\text{TRST}}$ Timing Diagram

Table 99. JTAG Timing

| ID | Parameter ^{1,2} | All Frequencies | | Unit |
|-----|---|-----------------|-----|------|
| | | Min | Max | |
| SJ0 | TCK frequency of operation $1/(3 \cdot T_{DC})^1$ | 0.001 | 22 | MHz |
| SJ1 | TCK cycle time in crystal mode | 45 | — | ns |
| SJ2 | TCK clock pulse width measured at V_M^2 | 22.5 | — | ns |
| SJ3 | TCK rise and fall times | — | 3 | ns |
| SJ4 | Boundary scan input data set-up time | 5 | — | ns |
| SJ5 | Boundary scan input data hold time | 24 | — | ns |
| SJ6 | TCK low to output data valid | — | 40 | ns |
| SJ7 | TCK low to output high impedance | — | 40 | ns |
| SJ8 | TMS, TDI data set-up time | 5 | — | ns |

Table 99. JTAG Timing (continued)

| ID | Parameter ^{1,2} | All Frequencies | | Unit |
|------|---|-----------------|-----|------|
| | | Min | Max | |
| SJ9 | TMS, TDI data hold time | 25 | — | ns |
| SJ10 | TCK low to TDO data valid | — | 44 | ns |
| SJ11 | TCK low to TDO high impedance | — | 44 | ns |
| SJ12 | $\overline{\text{TRST}}$ assert time | 100 | — | ns |
| SJ13 | $\overline{\text{TRST}}$ set-up time to TCK low | 40 | — | ns |

¹ T_{DC} = target frequency of SJC

² V_M = mid-point voltage

4.7.14 SPDIF Timing Parameters

Table 100 shows the timing parameters for the Sony/Philips Digital Interconnect Format (SPDIF).

Table 100. SPDIF Timing

| Characteristics | Symbol | All Frequencies | | Unit |
|--------------------------------|--------|-----------------|------|------|
| | | Min | Max | |
| SPDIFOUT output (load = 50 pF) | — | — | 1.5 | ns |
| • Skew | | — | 24.2 | |
| • Transition rising | | — | 31.3 | |
| • Transition falling | | | | |
| SPDIFOUT output (load = 30 pF) | — | — | 1.5 | ns |
| • Skew | | — | 13.6 | |
| • Transition rising | | — | 18.0 | |
| • Transition falling | | | | |

4.7.15 SSI Timing Parameters

This section describes the timing parameters of the SSI module. The connectivity of the serial synchronous interfaces is summarized in Table 101.

Table 101. AUDMUX Port Allocation

| Port | Signal Nomenclature | Type and Access |
|---------------|---------------------|-------------------------------------|
| AUDMUX port 1 | SSI 1 | Internal |
| AUDMUX port 2 | SSI 2 | Internal |
| AUDMUX port 3 | AUD3 | External—AUD3 I/O |
| AUDMUX port 4 | AUD4 | External—EIM or CSPI1 I/O via IOMUX |
| AUDMUX port 5 | AUD5 | External—EIM or SD1 I/O via IOMUX |

Table 101. AUDMUX Port Allocation (continued)

| Port | Signal Nomenclature | Type and Access |
|---------------|---------------------|---------------------------------|
| AUDMUX port 6 | AUD6 | External—EIM or DISP2 via IOMUX |
| AUDMUX port 7 | SSI 3 | Internal |

NOTE

- The terms WL and BL used in the timing diagrams and tables refer to Word Length (WL) and Bit Length (BL).
- The SSI timing diagrams use generic signal names wherein the names used in the *i.MX51 Multimedia Applications Processor Reference Manual* (MCIMX51RM) are channel specific signal names. For example, a channel clock referenced in the IOMUXC chapter as AUD3_TXC appears in the timing diagram as TXC.

4.7.15.1 SSI Transmitter Timing with Internal Clock

Figure 92 depicts the SSI transmitter internal clock timing and Table 102 lists the timing parameters for the SSI transmitter internal clock.

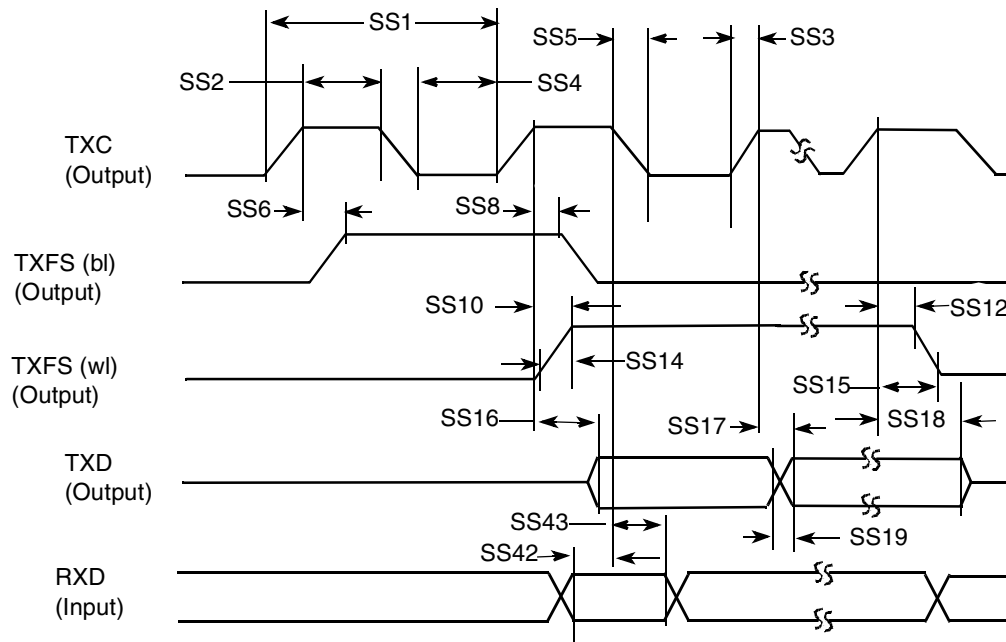

Note: SRXD input in synchronous mode only

Figure 92. SSI Transmitter Internal Clock Timing Diagram

Table 102. SSI Transmitter Timing with Internal Clock

| ID | Parameter | Min | Max | Unit |
|---|--|------|------|------|
| Internal Clock Operation | | | | |
| SS1 | (Tx/Rx) CK clock period | 81.4 | — | ns |
| SS2 | (Tx/Rx) CK clock high period | 36.0 | — | ns |
| SS3 | (Tx/Rx) CK clock rise time | — | 6.0 | ns |
| SS4 | (Tx/Rx) CK clock low period | 36.0 | — | ns |
| SS5 | (Tx/Rx) CK clock fall time | — | 6.0 | ns |
| SS6 | (Tx) CK high to FS (bl) high | — | 15.0 | ns |
| SS8 | (Tx) CK high to FS (bl) low | — | 15.0 | ns |
| SS10 | (Tx) CK high to FS (wl) high | — | 15.0 | ns |
| SS12 | (Tx) CK high to FS (wl) low | — | 15.0 | ns |
| SS14 | (Tx/Rx) Internal FS rise time | — | 6.0 | ns |
| SS15 | (Tx/Rx) Internal FS fall time | — | 6.0 | ns |
| SS16 | (Tx) CK high to STXD valid from high impedance | — | 15.0 | ns |
| SS17 | (Tx) CK high to STXD high/low | — | 15.0 | ns |
| SS18 | (Tx) CK high to STXD high impedance | — | 15.0 | ns |
| SS19 | STXD rise/fall time | — | 6.0 | ns |
| Synchronous Internal Clock Operation | | | | |
| SS42 | SRXD setup before (Tx) CK falling | 30 | — | ns |
| SS43 | SRXD hold after (Tx) CK falling | 0.0 | — | ns |
| SS52 | Loading | — | 25.0 | pF |

NOTE

- All the timings for the SSI are given for a non-inverted serial clock polarity (TSCKP/RSCKP = 0) and a non-inverted frame sync (TFSI/RFSI = 0). If the polarity of the clock and/or the frame sync have been inverted, all the timing remains valid by inverting the clock signal STCK/SRCK and/or the frame sync STFS/SRFS shown in the tables and in the figures.
- All timings are on Audiomux Pads when SSI is being used for data transfer.
- The terms WL and BL refer to Word Length (WL) and Bit Length (BL).
- "Tx" and "Rx" refer to the Transmit and Receive sections of the SSI.
- For internal Frame Sync operation using external clock, the FS timing is same as that of Tx Data (for example, during AC97 mode of operation).

4.7.15.2 SSI Receiver Timing with Internal Clock

Figure 93 depicts the SSI receiver internal clock timing and Table 103 lists the timing parameters for the SSI receiver internal clock.

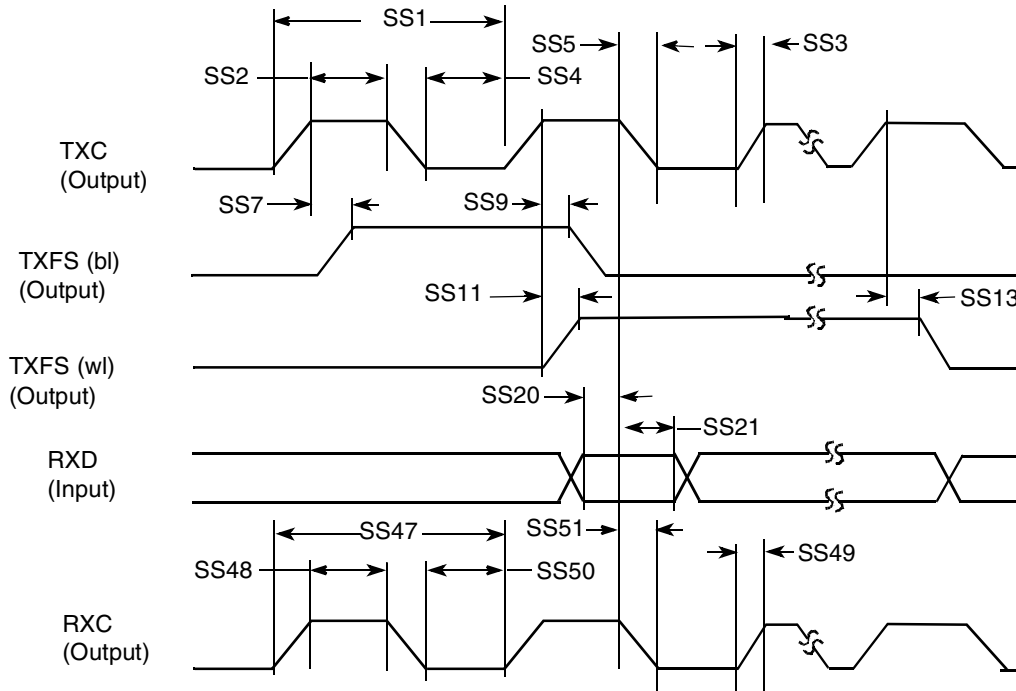

Figure 93. SSI Receiver Internal Clock Timing Diagram

Table 103. SSI Receiver Timing with Internal Clock

| ID | Parameter | Min | Max | Unit |
|---------------------------------|------------------------------------|------|------|------|
| Internal Clock Operation | | | | |
| SS1 | (Tx/Rx) CK clock period | 81.4 | — | ns |
| SS2 | (Tx/Rx) CK clock high period | 36.0 | — | ns |
| SS3 | (Tx/Rx) CK clock rise time | — | 6.0 | ns |
| SS4 | (Tx/Rx) CK clock low period | 36.0 | — | ns |
| SS5 | (Tx/Rx) CK clock fall time | — | 6.0 | ns |
| SS7 | (Rx) CK high to FS (bl) high | — | 15.0 | ns |
| SS9 | (Rx) CK high to FS (bl) low | — | 15.0 | ns |
| SS11 | (Rx) CK high to FS (wl) high | — | 15.0 | ns |
| SS13 | (Rx) CK high to FS (wl) low | — | 15.0 | ns |
| SS20 | SRXD setup time before (Rx) CK low | 30 | — | ns |
| SS21 | SRXD hold time after (Rx) CK low | 0.0 | — | ns |

Table 103. SSI Receiver Timing with Internal Clock (continued)

| ID | Parameter | Min | Max | Unit |
|-------------------------------------|--------------------------------|-------|-----|------|
| Oversampling Clock Operation | | | | |
| SS47 | Oversampling clock period | 15.04 | — | ns |
| SS48 | Oversampling clock high period | 6.0 | — | ns |
| SS49 | Oversampling clock rise time | — | 3.0 | ns |
| SS50 | Oversampling clock low period | 6.0 | — | ns |
| SS51 | Oversampling clock fall time | — | 3.0 | ns |

NOTE

- All the timings for the SSI are given for a non-inverted serial clock polarity (TSCKP/RSCCKP = 0) and a non-inverted frame sync (TFSI/RFSI = 0). If the polarity of the clock and/or the frame sync have been inverted, all the timing remains valid by inverting the clock signal STCK/SRCK and/or the frame sync STFS/SRFS shown in the tables and in the figures.
- All timings are on Audiomux Pads when SSI is being used for data transfer.
- “Tx” and “Rx” refer to the Transmit and Receive sections of the SSI.
- The terms WL and BL refer to Word Length (WL) and Bit Length (BL).
- For internal Frame Sync operation using external clock, the FS timing is same as that of Tx Data (for example, during AC97 mode of operation).

4.7.15.3 SSI Transmitter Timing with External Clock

Figure 94 depicts the SSI transmitter external clock timing and Table 104 lists the timing parameters for the SSI transmitter external clock.

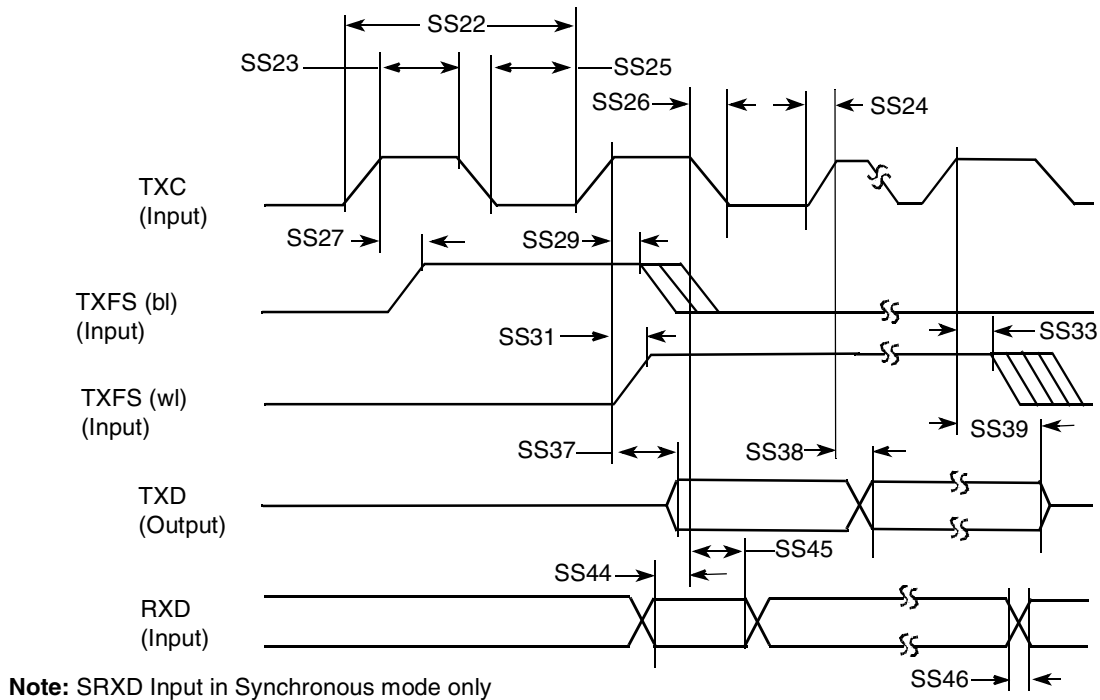

Figure 94. SSI Transmitter External Clock Timing Diagram

Table 104. SSI Transmitter Timing with External Clock

| ID | Parameter | Min | Max | Unit |
|---------------------------------|--|-------|------|------|
| External Clock Operation | | | | |
| SS22 | (Tx/Rx) CK clock period | 81.4 | — | ns |
| SS23 | (Tx/Rx) CK clock high period | 36.0 | — | ns |
| SS24 | (Tx/Rx) CK clock rise time | — | 6.0 | ns |
| SS25 | (Tx/Rx) CK clock low period | 36.0 | — | ns |
| SS26 | (Tx/Rx) CK clock fall time | — | 6.0 | ns |
| SS27 | (Tx) CK high to FS (bl) high | -10.0 | 15.0 | ns |
| SS29 | (Tx) CK high to FS (bl) low | 10.0 | — | ns |
| SS31 | (Tx) CK high to FS (wl) high | -10.0 | 15.0 | ns |
| SS33 | (Tx) CK high to FS (wl) low | 10.0 | — | ns |
| SS37 | (Tx) CK high to STXD valid from high impedance | — | 15.0 | ns |
| SS38 | (Tx) CK high to STXD high/low | — | 30 | ns |

Table 104. SSI Transmitter Timing with External Clock (continued)

| ID | Parameter | Min | Max | Unit |
|---|-------------------------------------|------|------|------|
| SS39 | (Tx) CK high to STXD high impedance | — | 15.0 | ns |
| Synchronous External Clock Operation | | | | |
| SS44 | SRXD setup before (Tx) CK falling | 10.0 | — | ns |
| SS45 | SRXD hold after (Tx) CK falling | 2.0 | — | ns |
| SS46 | SRXD rise/fall time | — | 6.0 | ns |

NOTE

- All the timings for the SSI are given for a non-inverted serial clock polarity (TSCKP/RSCCKP = 0) and a non-inverted frame sync (TFSI/RFSI = 0). If the polarity of the clock and/or the frame sync have been inverted, all the timing remains valid by inverting the clock signal STCK/SRCK and/or the frame sync STFS/SRFS shown in the tables and in the figures.
- All timings are on Audiomux Pads when SSI is being used for data transfer.
- “Tx” and “Rx” refer to the Transmit and Receive sections of the SSI.
- The terms WL and BL refer to Word Length (WL) and Bit Length (BL).
- For internal Frame Sync operation using external clock, the FS timing is same as that of Tx Data (for example, during AC97 mode of operation).

4.7.15.4 SSI Receiver Timing with External Clock

Figure 95 depicts the SSI receiver external clock timing and Table 105 lists the timing parameters for the SSI receiver external clock.

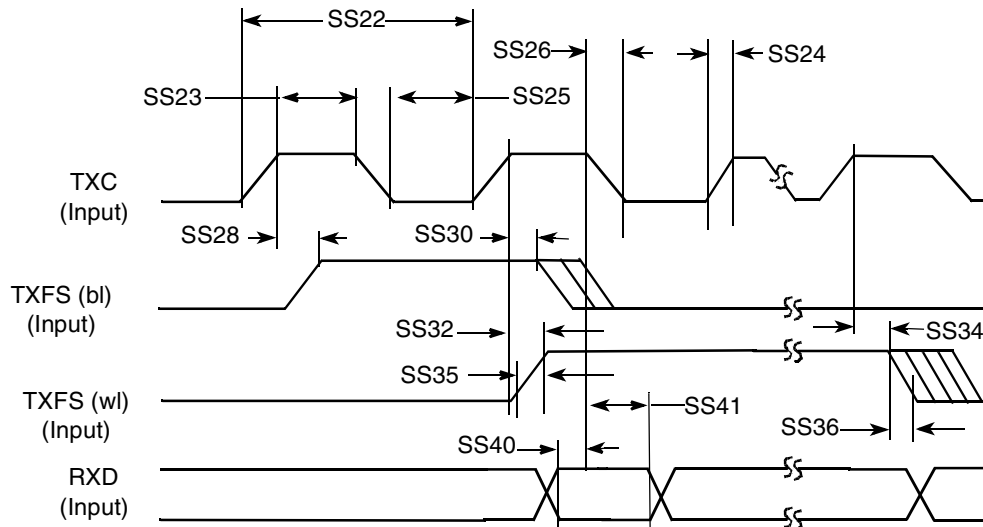

Figure 95. SSI Receiver External Clock Timing Diagram

Table 105. SSI Receiver Timing with External Clock

| ID | Parameter | Min | Max | Unit |
|---------------------------------|------------------------------------|------|------|------|
| External Clock Operation | | | | |
| SS22 | (Tx/Rx) CK clock period | 81.4 | — | ns |
| SS23 | (Tx/Rx) CK clock high period | 36 | — | ns |
| SS24 | (Tx/Rx) CK clock rise time | — | 6.0 | ns |
| SS25 | (Tx/Rx) CK clock low period | 36 | — | ns |
| SS26 | (Tx/Rx) CK clock fall time | — | 6.0 | ns |
| SS28 | (Rx) CK high to FS (bl) high | -10 | 15.0 | ns |
| SS30 | (Rx) CK high to FS (bl) low | 10 | — | ns |
| SS32 | (Rx) CK high to FS (wl) high | -10 | 15.0 | ns |
| SS34 | (Rx) CK high to FS (wl) low | 10 | — | ns |
| SS35 | (Tx/Rx) External FS rise time | — | 6.0 | ns |
| SS36 | (Tx/Rx) External FS fall time | — | 6.0 | ns |
| SS40 | SRXD setup time before (Rx) CK low | 10 | — | ns |
| SS41 | SRXD hold time after (Rx) CK low | 2 | — | ns |

NOTE

- All the timings for the SSI are given for a non-inverted serial clock polarity (TSCKP/RSCKP = 0) and a non-inverted frame sync (TFSI/RFSI = 0). If the polarity of the clock and/or the frame sync have been inverted, all the timing remains valid by inverting the clock signal STCK/SRCK and/or the frame sync STFS/SRFS shown in the tables and in the figures.
- All timings are on Audiomux Pads when SSI is being used for data transfer.
- “Tx” and “Rx” refer to the Transmit and Receive sections of the SSI.
- The terms WL and BL refer to Word Length (WL) and Bit Length (BL).
- For internal Frame Sync operation using external clock, the FS timing is same as that of Tx Data (for example, during AC97 mode of operation).

4.7.16 UART

Table 106 shows the UART I/O configuration based on which mode is enabled.

Table 106. UART I/O Configuration vs. Mode

| Port | DTE Mode | | DCE Mode | |
|---------|-----------|-----------------------------|-----------|-----------------------------|
| | Direction | Description | Direction | Description |
| RTS | Output | RTS from DTE to DCE | Input | RTS from DTE to DCE |
| CTS | Input | CTS from DCE to DTE | Output | CTS from DCE to DTE |
| DTR | Output | DTR from DTE to DCE | Input | DTR from DTE to DCE |
| DSR | Input | DSR from DCE to DTE | Output | DSR from DCE to DTE |
| DCD | Input | DCD from DCE to DTE | Output | DCD from DCE to DTE |
| RI | Input | RING from DCE to DTE | Output | RING from DCE to DTE |
| TXD_MUX | Input | Serial data from DCE to DTE | Output | Serial data from DCE to DTE |
| RXD_MUX | Output | Serial data from DTE to DCE | Input | Serial data from DTE to DCE |

4.7.16.1 UART Electrical

This section describes the electrical information of the UART module.

4.7.16.1.1 UART RS-232 Serial Mode Timing

UART Transmitter

Figure 96 depicts the transmit timing of UART in RS-232 serial mode, with 8 data bit/1 stop bit format. Table 107 lists the UART RS-232 serial mode transmit timing characteristics.

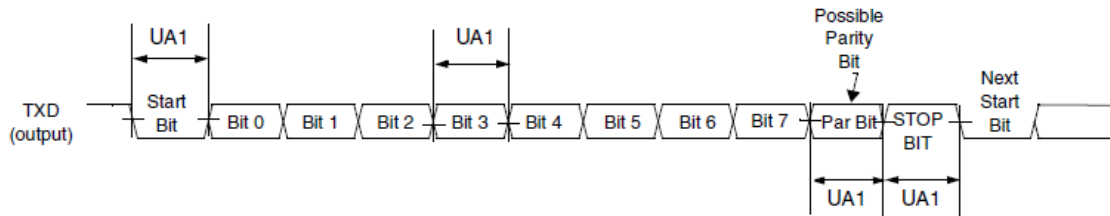

Figure 96. UART RS-232 Serial Mode Transmit Timing Diagram

Table 107. UART RS-232 Serial Mode Transmit Timing Diagram

| ID | Parameter | Symbol | Min | Max | Units |
|-----|-------------------|------------|-------------------------------------|-----------------------------------|-------|
| UA1 | Transmit Bit Time | t_{Tbit} | $1/F_{baud_rate} - T_{ref_clk}^2$ | $1/F_{baud_rate} + T_{ref_clk}$ | — |

¹ $1/F_{baud_rate}$: Baud rate frequency. The maximum baud rate the UART can support is (ipg_perclk frequency)/16.

² T_{ref_clk} : The period of UART reference clock ref_clk (ipg_perclk after RFDIV divider).

UART Receiver

Figure 97 depicts the RS-232 serial mode receive timing, with 8 data bit/1 stop bit format. Table 108 lists serial mode receive timing characteristics.

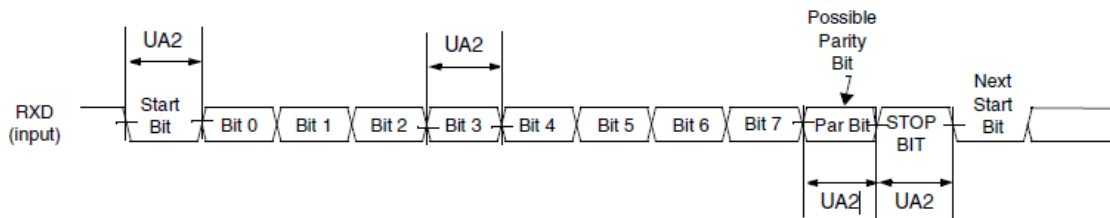

Figure 97. UART RS-232 Serial Mode Receive Timing Diagram

Table 108. UART RS-232 Serial Mode Transmit Timing Diagram

| ID | Parameter | Symbol | Min | Max | Units |
|-----|-------------------------------|------------|---|---|-------|
| UA1 | Receive Bit Time ¹ | t_{Rbit} | $1/F_{baud_rate} - 1/(16 \times F_{baud_rate})$ | $1/F_{baud_rate} + 1/(16 \times F_{baud_rate})$ | — |

¹ The UART receiver can tolerate $1/(16 \times F_{baud_rate})$ tolerance in each bit. But accumulation tolerance in one frame must not exceed $3/(16 \times F_{baud_rate})$.

² F_{baud_rate} : Baud rate frequency. The maximum baud rate the UART can support is (ipg_perclk frequency)/16.

4.7.16.1.2 UART IrDA Mode Timing

The following subsections give the UART transmit and receive timings in IrDA mode.

UART IrDA Mode Transmitter

Figure 98 depicts the UART IrDA mode transmit timing, with 8 data bit/1 stop bit format. Table 109 lists the transmit timing characteristics.

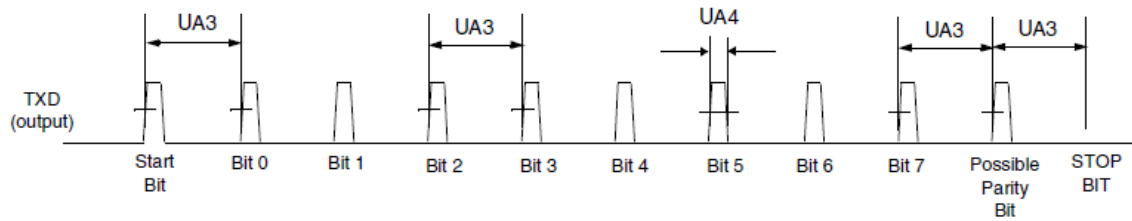

Figure 98. UART IrDA Mode Transmit Timing Diagram

Table 109. IrDA Mode Transmit Timing Parameters

| ID | Parameter | Symbol | Min | Max | Units |
|-----|--------------------------------|----------------|---|---|-------|
| UA3 | Transmit Bit Time in IrDA mode | t_{TIRbit} | $1/F_{baud_rate} - T_{ref_clk}^2$ | $1/F_{baud_rate} + T_{ref_clk}$ | — |
| UA4 | Transmit IR Pulse Duration | $t_{TIRpulse}$ | $(3/16) \times (1/F_{baud_rate}) - T_{ref_clk}$ | $(3/16) \times (1/F_{baud_rate}) + T_{ref_clk}$ | — |

¹ F_{baud_rate} : Baud rate frequency. The maximum baud rate the UART can support is (ipg_perclk frequency)/16.

² T_{ref_clk} : The period of UART reference clock ref_clk (ipg_perclk after RFDIV divider).

UART IrDA Mode Receiver

Figure 99 depicts the UART IrDA mode receive timing, with 8 data bit/1 stop bit format. Table 110 lists the receive timing characteristics.

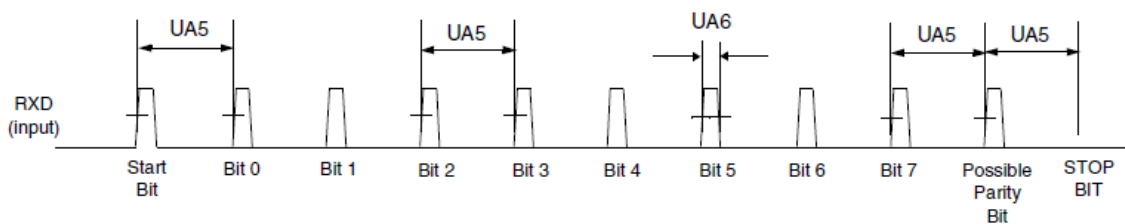

Figure 99. UART IrDA Mode Receive Timing Diagram

Table 110. IrDA Mode Receive Timing Parameters

| ID | Parameter | Symbol | Min | Max | Units |
|-----|--|----------------|---|---|-------|
| UA5 | Receive Bit Time ¹ in IrDA mode | t_{RIRbit} | $1/F_{baud_rate}^2 - 1/(16 \times F_{baud_rate})$ | $1/F_{baud_rate} + 1/(16 \times F_{baud_rate})$ | — |
| UA6 | Receive IR Pulse Duration | $t_{RIRpulse}$ | 1.41 us | $(5/16) \times (1/F_{baud_rate})$ | — |

¹ The UART receiver can tolerate $1/(16 \times F_{baud_rate})$ tolerance in each bit. But accumulation tolerance in one frame must not exceed $3/(16 \times F_{baud_rate})$.

Electrical Characteristics

² Fbaud_rate: Baud rate frequency. The maximum baud rate the UART can support is (ipg_perclk frequency)/16.

4.7.17 USBOH3 Parameters

This section describes the electrical parameters of the USB OTG port and USB HOST ports. For on-chip USB PHY parameters see [Section 4.7.19, “USB PHY Parameters.”](#)

4.7.17.1 USB Serial Interface

In order to support four serial different interfaces, the USB serial transceiver can be configured to operate in one of four modes:

- DAT_SE0 bidirectional, 3-wire mode
- DAT_SE0 unidirectional, 6-wire mode
- VP_VM bidirectional, 4-wire mode
- VP_VM unidirectional, 6-wire mode

The USB controller does not support ULPI Serial mode. Only the legacy serial mode is supported.

[Table 111](#) shows the serial mode signal map for 6-pin Full speed/Low speed (FsLs) serial mode.

[Table 112](#) shows the serial mode signal map for 3-pin FsLs serial mode.

Table 111. Serial Mode Signal Map for 6-pin FsLs Serial Mode

| Signal | Maps to | Direction | Description |
|-----------|---------|-----------|---|
| tx_enable | data(0) | In | Active high transmit enable |
| tx_dat | data(1) | In | Transmit differential data on D+/D- |
| tx_se0 | data(2) | In | Transmit single-ended zero on D+/D- |
| int | data(3) | Out | Active high interrupt indication Must be asserted whenever any unmasked interrupt occurs |
| rx_dp | data(4) | Out | Single-ended receive data from D+ |
| rx_dm | data(5) | Out | Single-ended receive data from D- |
| rx_rcv | data(6) | Out | Differential receive data from D+/D- |
| Reserved | data(7) | Out | Reserved The PHY must drive this signal low |

Table 112. Serial Mode Signal Map for 3-pin FsLs Serial Mode

| Signal | Maps to | Direction | Description |
|-----------|---------|-----------|--|
| tx_enable | data(0) | In | Active high transmit enable |
| dat | data(1) | I/O | Transmit differential data on D+/D- when tx_enable is high Receive differential data on D+/D- when tx_enable is low |
| se0 | data(2) | I/O | Transmit single-ended zero on D+/D- when tx_enable is high Receive single-ended zero on D+/D- when tx_enable is low |
| int | data(3) | Out | Active high interrupt indication Must be asserted whenever any unmasked interrupt occurs |

4.7.17.1.1 USB DAT_SE0 Bi-Directional Mode

Table 113 shows the signal definitions in DAT_SE0 bi-directional mode and Figure 100 shows the USB transmit waveform in DAT_SE0 bi-directional mode.

Table 113. Signal Definitions—DAT_SE0 Bi-Directional Mode

| Name | Direction | Signal Description |
|------------|-----------|--|
| USB_TXOE_B | Out | Transmit enable, active low |
| USB_DAT_VP | Out In | TX data when USB_TXOE_B is low Differential RX data when USB_TXOE_B is high |
| USB_SE0_VM | Out In | SE0 drive when USB_TXOE_B is low SE0 RX indicator when USB_TXOE_B is high |

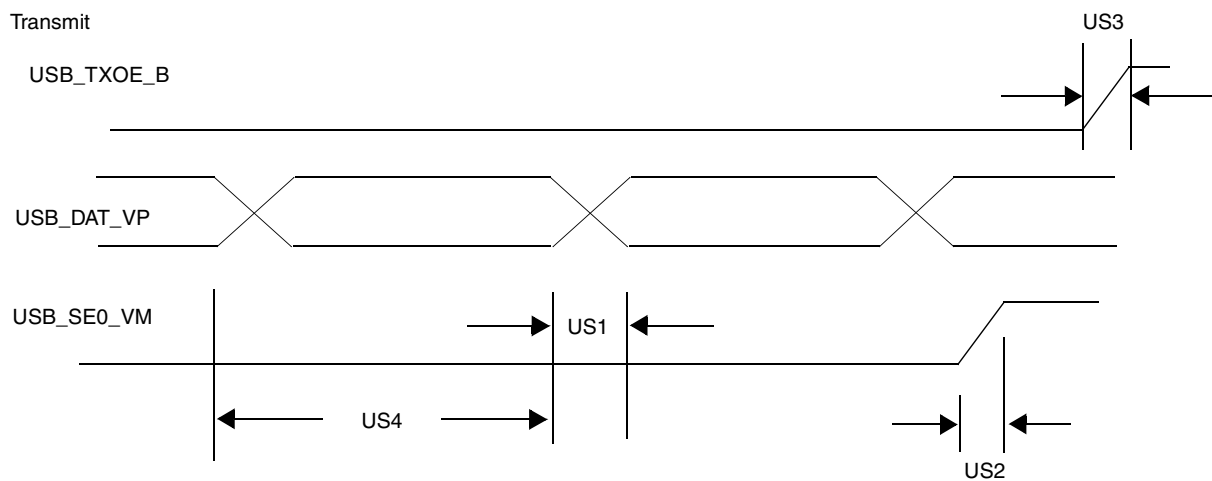

Figure 100. USB Transmit Waveform in DAT_SE0 Bi-Directional Mode

Figure 101 shows the USB receive waveform in DAT_SE0 bi-directional mode and Table 114 shows the definitions of USB receive waveform in DAT_SE0 bi-directional mode.

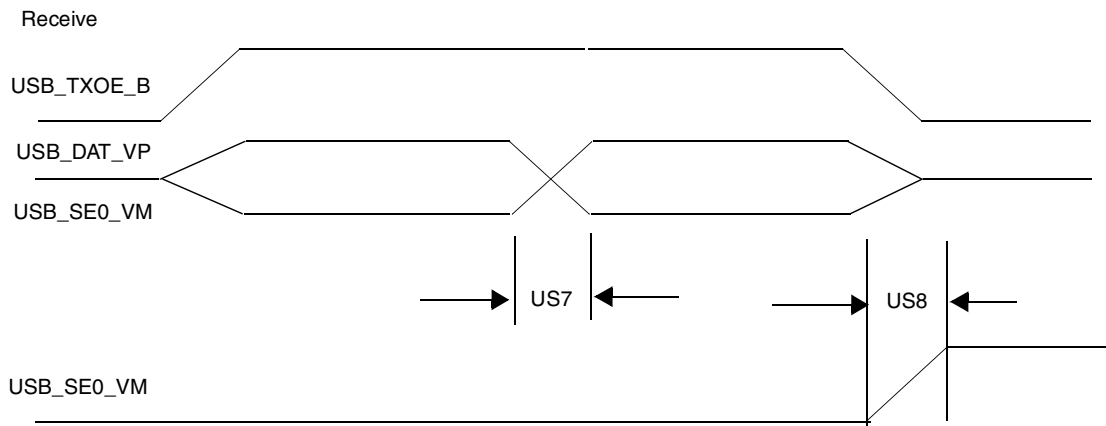

Figure 101. USB Receive Waveform in DAT_SE0 Bi-Directional Mode

Table 114. Definitions of USB Receive Waveform in DAT_SE0 Bi-Directional Mode

| ID | Parameter | Signal Name | Direction | Min | Max | Unit | Conditions/Reference Signal |
|-----|-------------------|-------------|-----------|------|------|------|-----------------------------|
| US1 | TX Rise/Fall Time | USB_DAT_VP | Out | — | 5.0 | ns | 50 pF |
| US2 | TX Rise/Fall Time | USB_SE0_VM | Out | — | 5.0 | ns | 50 pF |
| US3 | TX Rise/Fall Time | USB_TXOE_B | Out | — | 5.0 | ns | 50 pF |
| US4 | TX Duty Cycle | USB_DAT_VP | Out | 49.0 | 51.0 | % | — |
| US7 | RX Rise/Fall Time | USB_DAT_VP | In | — | 3.0 | ns | 35 pF |
| US8 | RX Rise/Fall Time | USB_SE0_VM | In | — | 3.0 | ns | 35 pF |

4.7.17.1.2 USB DAT_SE0 Unidirectional Mode

Table 115 shows the signal definitions in DAT_SE0 unidirectional mode

Table 115. Signal Definitions—DAT_SE0 Unidirectional Mode

| Name | Direction | Signal Description |
|------------|-----------|--|
| USB_TXOE_B | Out | Transmit enable, active low |
| USB_DAT_VP | Out | TX data when USB_TXOE_B is low |
| USB_SE0_VM | Out | SE0 drive when USB_TXOE_B is low |
| USB_VP1 | In | Buffered data on DP when USB_TXOE_B is high |
| USB_VM1 | In | Buffered data on DM when USB_TXOE_B is high |
| USB_RCV | In | Differential RX data when USB_TXOE_B is high |

Figure 102 and Figure 103 shows the USB transmit/receive waveform in DAT_SE0 uni-directional mode respectively.

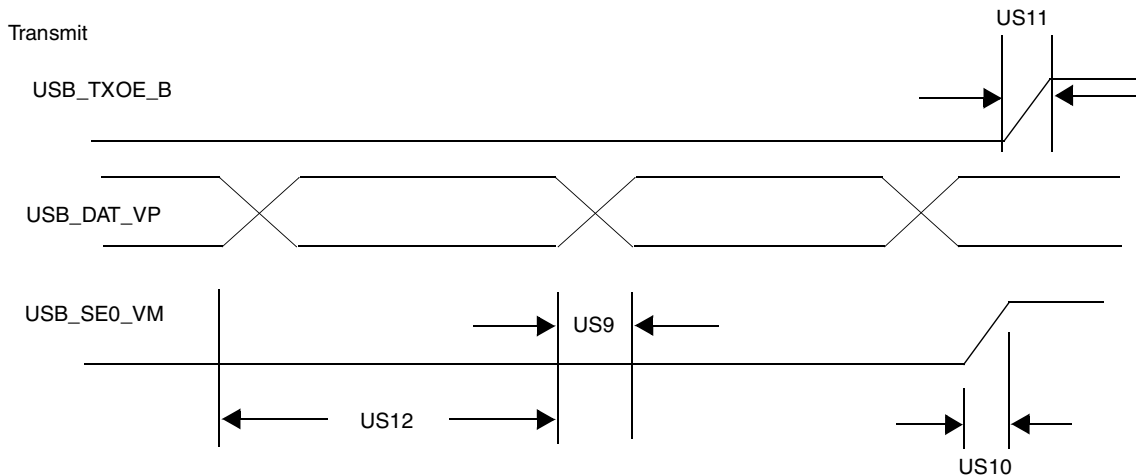

Figure 102. USB Transmit Waveform in DAT_SE0 Uni-directional Mode

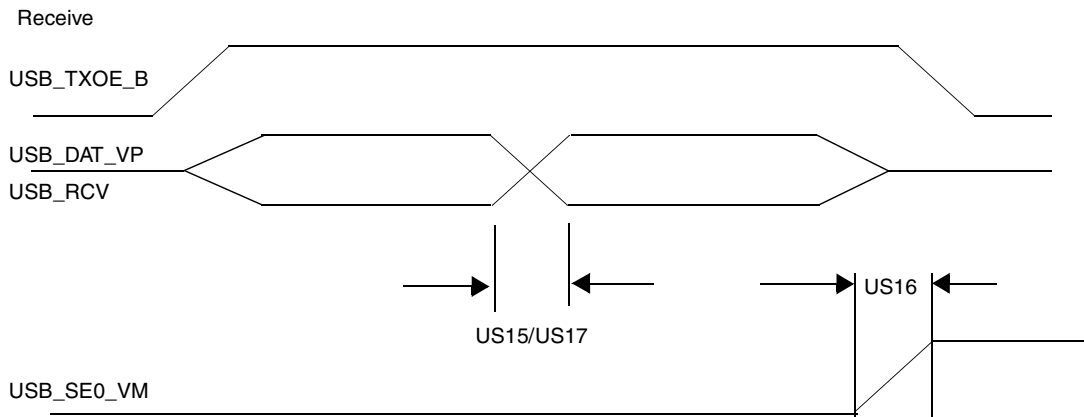

Figure 103. USB Receive Waveform in DAT_SE0 Uni-directional Mode

Table 116 shows the USB port timing specification in DAT_SE0 uni-directional mode.

Table 116. USB Port Timing Specification in DAT_SE0 Uni-Directional Mode

| ID | Parameter | Signal Name | Signal Source | Min | Max | Unit | Condition/Reference Signal |
|------|-------------------|-------------|---------------|------|------|------|----------------------------|
| US9 | TX Rise/Fall Time | USB_DAT_VP | Out | — | 5.0 | ns | 50 pF |
| US10 | TX Rise/Fall Time | USB_SE0_VM | Out | — | 5.0 | ns | 50 pF |
| US11 | TX Rise/Fall Time | USB_TXOE_B | Out | — | 5.0 | ns | 50 pF |
| US12 | TX Duty Cycle | USB_DAT_VP | Out | 49.0 | 51.0 | % | — |
| US15 | RX Rise/Fall Time | USB_VP1 | In | — | 3.0 | ns | 35 pF |
| US16 | RX Rise/Fall Time | USB_VM1 | In | — | 3.0 | ns | 35 pF |
| US17 | RX Rise/Fall Time | USB_RCV | In | — | 3.0 | ns | 35 pF |

4.7.17.1.3 USB VP_VM Bi-Directional Mode

Table 117 shows the signal definitions in VP_VM bi-directional mode. Figure 104 and Figure 105 shows the USB transmit/receive waveform in VP_VM bi-directional mode respectively.

Table 117. Signal Definitions—VP_VM Bi-Directional Mode

| Name | Direction | Signal Description |
|------------|---------------------|---|
| USB_TXOE_B | Out | Transmit enable, active low |
| USB_DAT_VP | Out (Tx) In (Rx) | TX VP data when USB_TXOE_B is low RX VP data when USB_TXOE_B is high |
| USB_SE0_VM | Out (Tx) In (Rx) | TX VM data when USB_TXOE_B low RX VM data when USB_TXOE_B high |
| USB_RCV | In | Differential RX data |

Electrical Characteristics

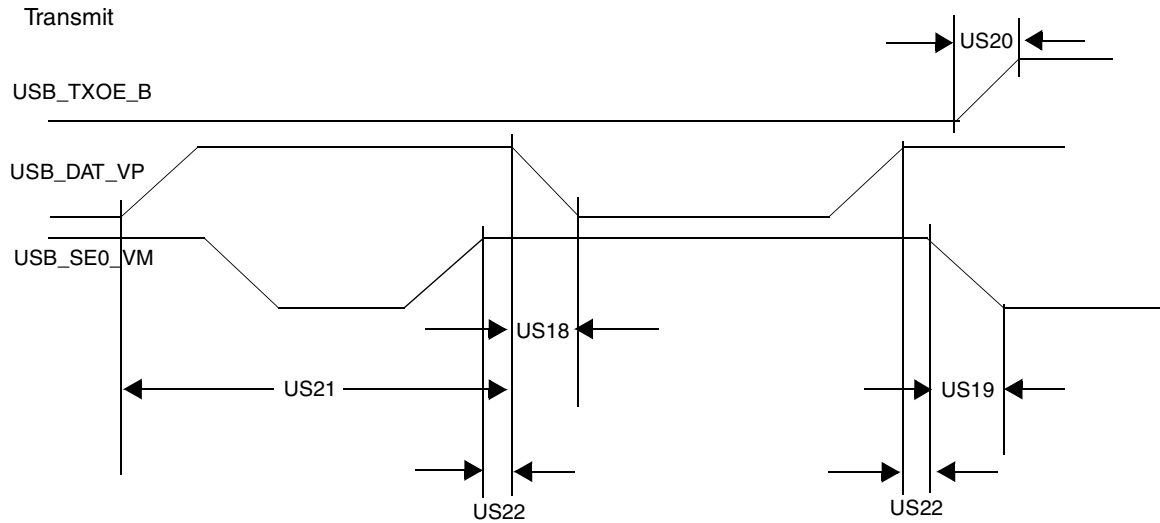

Figure 104. USB Transmit Waveform in VP_VM Bi-Directional Mode

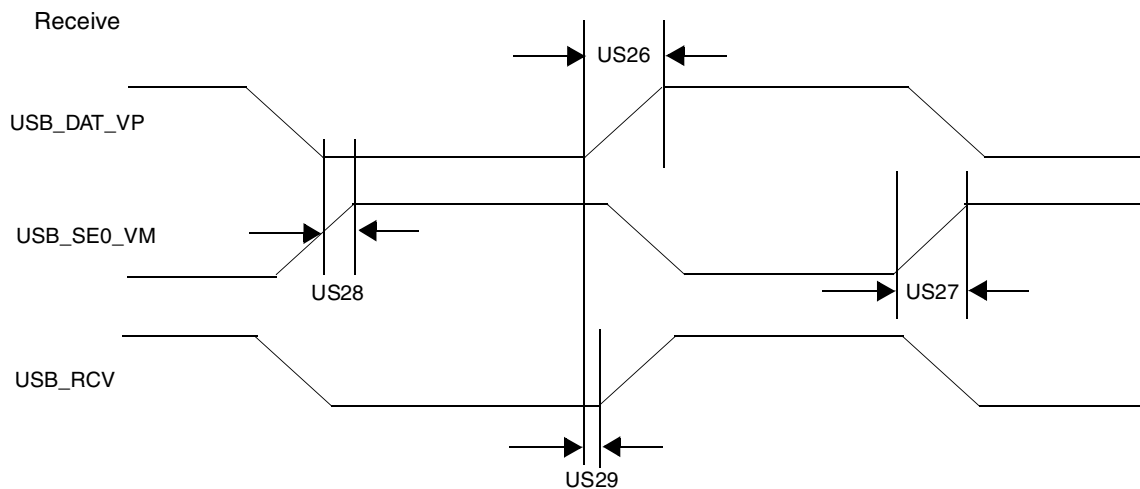

Figure 105. USB Receive Waveform in VP_VM Bi-Directional Mode

Table 118 shows the USB port timing specification in VP_VM bi-directional mode.

Table 118. USB Port Timing Specification in VP_VM Bi-directional Mode

| ID | Parameter | Signal Name | Direction | Min | Max | Unit | Condition/Reference Signal |
|------|-------------------|-------------|-----------|------|------|------|----------------------------|
| US18 | TX Rise/Fall Time | USB_DAT_VP | Out | — | 5.0 | ns | 50 pF |
| US19 | TX Rise/Fall Time | USB_SE0_VM | Out | — | 5.0 | ns | 50 pF |
| US20 | TX Rise/Fall Time | USB_TXOE_B | Out | — | 5.0 | ns | 50 pF |
| US21 | TX Duty Cycle | USB_DAT_VP | Out | 49.0 | 51.0 | % | — |
| US22 | TX Overlap | USB_SE0_VM | Out | -3.0 | 3.0 | ns | USB_DAT_VP |

Table 118. USB Port Timing Specification in VP_VM Bi-directional Mode (continued)

| ID | Parameter | Signal Name | Direction | Min | Max | Unit | Condition/Reference Signal |
|------|-------------------|-------------|-----------|------|-----|------|----------------------------|
| US26 | RX Rise/Fall Time | USB_DAT_VP | In | — | 3.0 | ns | 35 pF |
| US27 | RX Rise/Fall Time | USB_SE0_VM | In | — | 3.0 | ns | 35 pF |
| US28 | RX Skew | USB_DAT_VP | In | -4.0 | 4.0 | ns | USB_SE0_VM |
| US29 | RX Skew | USB_RCV | In | -6.0 | 2.0 | ns | USB_DAT_VP |

4.7.17.1.4 USB VP_VM Uni-Directional Mode

Table 119 shows the signal definitions in VP_VM uni-directional mode. Figure 106 and Figure 107 shows the USB transmit/receive waveform in VP_VM uni-directional mode respectively.

Table 119. USB Signal Definitions—VP_VM Uni-Directional Mode

| Name | Direction | Signal Description |
|------------|-----------|------------------------------------|
| USB_TXOE_B | Out | Transmit enable, active low |
| USB_DAT_VP | Out | TX VP data when USB_TXOE_B is low |
| USB_SE0_VM | Out | TX VM data when USB_TXOE_B is low |
| USB_VP1 | In | RX VP data when USB_TXOE_B is high |
| USB_VM1 | In | RX VM data when USB_TXOE_B is high |
| USB_RCV | In | Differential RX data |

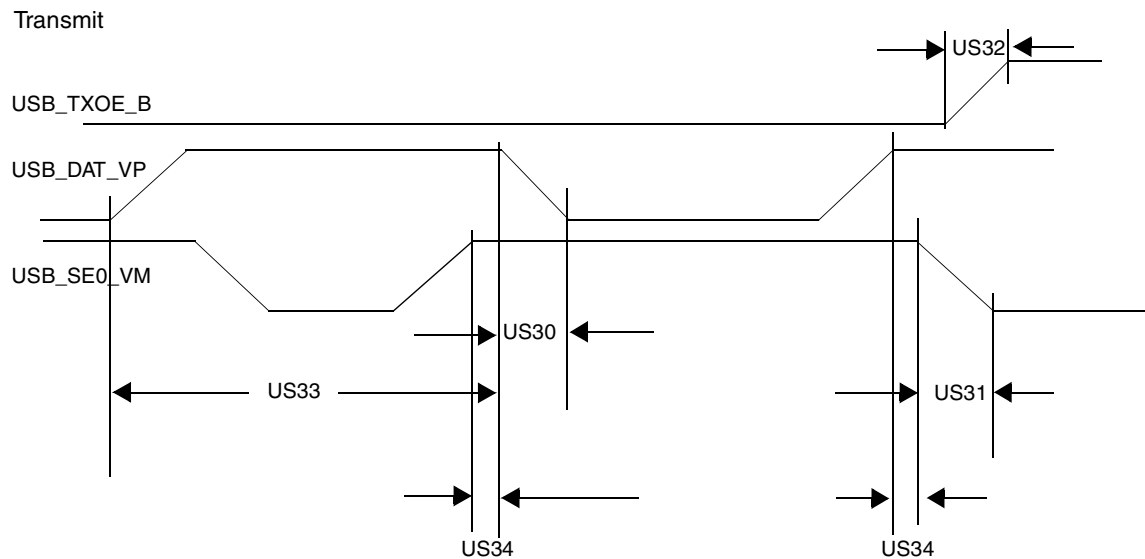
**Figure 106. USB Transmit Waveform in VP_VM Unidirectional Mode**

Electrical Characteristics

Receive

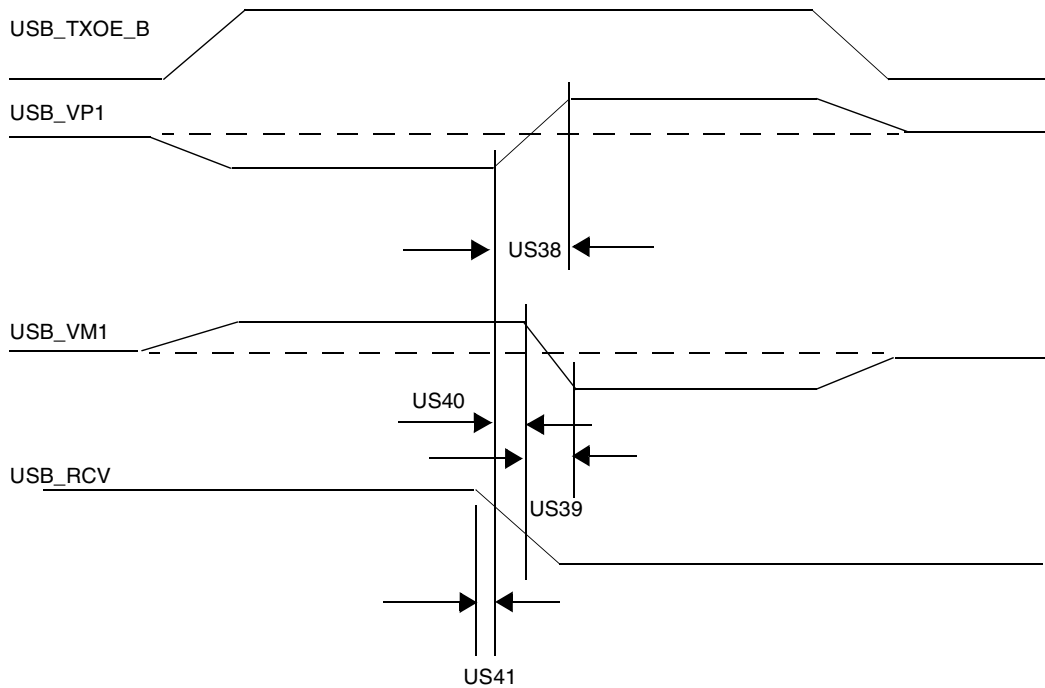

Figure 107. USB Receive Waveform in VP_VM Uni-directional Mode

Table 120 shows the USB port timing specification in VP_VM uni-directional mode.

Table 120. USB Timing Specification in VP_VM Unidirectional Mode

| ID | Parameter | Signal | Direction | Min | Max | Unit | Conditions / Reference Signal |
|------|-------------------|------------|-----------|------|------|------|-------------------------------|
| US30 | TX Rise/Fall Time | USB_DAT_VP | Out | — | 5.0 | ns | 50 pF |
| US31 | TX Rise/Fall Time | USB_SE0_VM | Out | — | 5.0 | ns | 50 pF |
| US32 | TX Rise/Fall Time | USB_TXOE_B | Out | — | 5.0 | ns | 50 pF |
| US33 | TX Duty Cycle | USB_DAT_VP | Out | 49.0 | 51.0 | % | — |
| US34 | TX Overlap | USB_SE0_VM | Out | -3.0 | 3.0 | ns | USB_DAT_VP |
| US38 | RX Rise/Fall Time | USB_VP1 | In | — | 3.0 | ns | 35 pF |
| US39 | RX Rise/Fall Time | USB_VM1 | In | — | 3.0 | ns | 35 pF |
| US40 | RX Skew | USB_VP1 | In | -4.0 | 4.0 | ns | USB_VM1 |
| US41 | RX Skew | USB_RCV | In | -6.0 | 2.0 | ns | USB_VP1 |

4.7.18 USB Parallel Interface Timing

Electrical and timing specifications of Parallel Interface are presented in the subsequent sections. [Table 121](#) shows the signal definitions in parallel mode. [Figure 108](#) shows the USB transmit/receive waveform in parallel mode. [Table 122](#) shows the USB timing specification for ULPI parallel mode.

Table 121. Signal Definitions—Parallel Interface (Normal ULPI)

| Name | Direction | Signal Description |
|---------------|-----------|--|
| USB_Clk | In | Interface clock. All interface signals are synchronous to Clock. |
| USB_Data[7:0] | I/O | Bi-directional data bus, driven low by the link during idle. Bus ownership is determined by Dir. |
| USB_Dir | In | Direction. Control the direction of the Data bus. |
| USB_Stp | Out | Stop. The link asserts this signal for 1 clock cycle to stop the data stream currently on the bus. |
| USB_Nxt | In | Next. The PHY asserts this signal to throttle the data. |

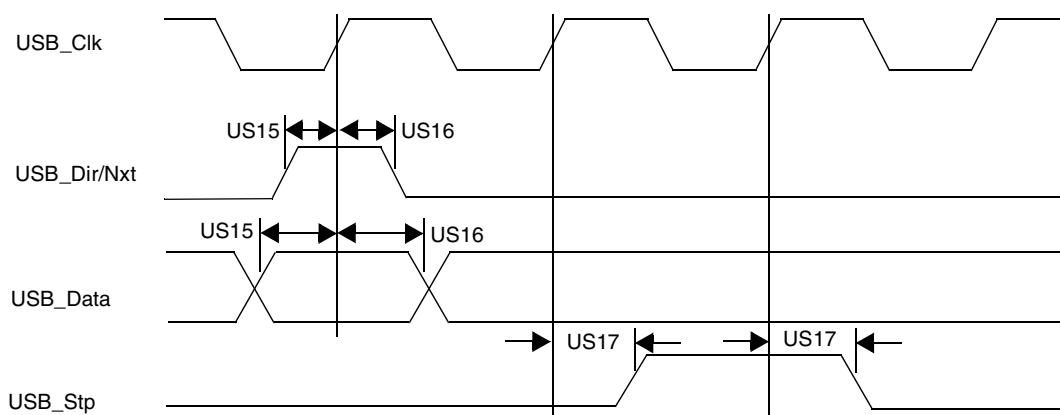

Figure 108. USB Transmit/Receive Waveform in Parallel Mode

Table 122. USB Timing Specification for ULPI Parallel Mode

| ID | Parameter | Min | Max | Unit | Conditions/ Reference Signal |
|------|--|-----|-----|------|---------------------------------|
| US15 | Setup Time (Dir, Nxt in, Data in) | 6 | — | ns | 10 pF |
| US16 | Hold Time (Dir, Nxt in, Data in) | 0 | — | ns | 10 pF |
| US17 | Output delay Time (Stp out, Data out) for H3 routed to DISP2 I/O ¹ and H1 | — | 9 | ns | 10 pF |
| US17 | Output delay Time (Stp out, Data out) for H2 | — | 11 | ns | 10 pF |

¹ H3 routed to NANDF I/O is recommended for Full and Low-Speed use only.

4.7.19 USB PHY Parameters

This section describes the USB PHY parameters.

4.7.19.1 USB PHY AC Parameters

Table 123 lists the AC timing parameters for USB PHY.

Table 123. USB PHY AC Timing Parameters

| Parameter | Conditions | Min | Typ | Max | Unit |
|-----------|------------|-----|-----|-----|------|
| trise | 1.5 Mbps | 75 | — | 300 | ns |
| | 12 Mbps | 4 | | 20 | |
| | 480 Mbps | 0.5 | | | |
| tfall | 1.5 Mbps | 75 | — | 300 | ns |
| | 12 Mbps | 4 | | 20 | |
| | 480 Mbps | 0.5 | | | |
| Jitter | 1.5 Mbps | — | — | 10 | ns |
| | 12 Mbps | | | 1 | |
| | 480 Mbps | | | 0.2 | |

4.7.19.2 USB PHY Additional Electrical Parameters

Table 124 lists the parameters for additional electrical characteristics for USB PHY.

Table 124. Additional Electrical Characteristics for USB PHY

| Parameter | Conditions | Min | Typ | Max | Unit |
|---|----------------|-------|-----|-----|------|
| Vcm DC (dc level measured at receiver connector) | HS Mode | -0.05 | — | 0.5 | V |
| | LS/FS Mode | 0.8 | | 2.5 | |
| Crossover Voltage | LS Mode | 1.3 | — | 2 | V |
| | FS Mode | 1.3 | | 2 | |
| Power supply ripple noise (analog 3.3 V) | <160 MHz | -50 | 0 | 50 | mV |
| Power supply ripple noise (analog 2.5 V) | <1.2 MHz | -10 | 0 | 10 | mV |
| | >1.2 MHz | -50 | 0 | 50 | |
| Power supply ripple noise (Digital 1.2) | All conditions | -50 | 0 | 50 | mV |

4.7.19.3 USB PHY System Clocking (SYSCLK)

Table 125 lists the USB PHY system clocking parameters.

Table 125. USB PHY System Clocking Parameters

| Parameter | Conditions | Min | Typ | Max | Unit |
|-----------------|------------|------|-----|-----|------|
| Clock deviation | — | -150 | — | 150 | ppm |
| Rise/fall time | — | — | — | 200 | ps |

Table 125. USB PHY System Clocking Parameters (continued)

| Parameter | Conditions | Min | Typ | Max | Unit |
|--------------------|------------|-----|-----|-----|------|
| Jitter (peak-peak) | <1.2 MHz | 0 | — | 50 | ps |
| Jitter (peak-peak) | >1.2 MHz | 0 | — | 100 | ps |
| Duty-cycle | — | 40 | — | 60 | % |

4.7.19.4 USB PHY Voltage Thresholds

Table 126 lists the USB PHY voltage thresholds.

Table 126. VBUS Comparators Thresholds

| Parameter | Conditions | Min | Typ | Max | Unit |
|--|------------|-----|------|------|------|
| A-Device Session Valid | — | 0.8 | 1.4 | 2.0 | V |
| B-Device Session Valid | — | 0.8 | 1.4 | 4.0 | V |
| B-Device Session End | — | 0.2 | 0.45 | 0.8 | V |
| VBUS Valid Comparator Threshold ¹ | — | 4.4 | 4.6 | 4.75 | V |

¹ For VBUS maximum rating, see Table 11 on page 18

5 Package Information and Contact Assignments

This section includes the contact assignment information and mechanical package drawing.

5.1 13 x 13 mm Package Information

This section contains the outline drawing, signal assignment map, ground/power/reference ID (by ball grid location) for the 13 × 13 mm, 0.5 mm pitch package.

5.1.1 BGA—Case 2058 13 x 13 mm, 0.5 mm Pitch

Figure 109 shows the top view, bottom view, and side view of the 13 ×13 mm package.

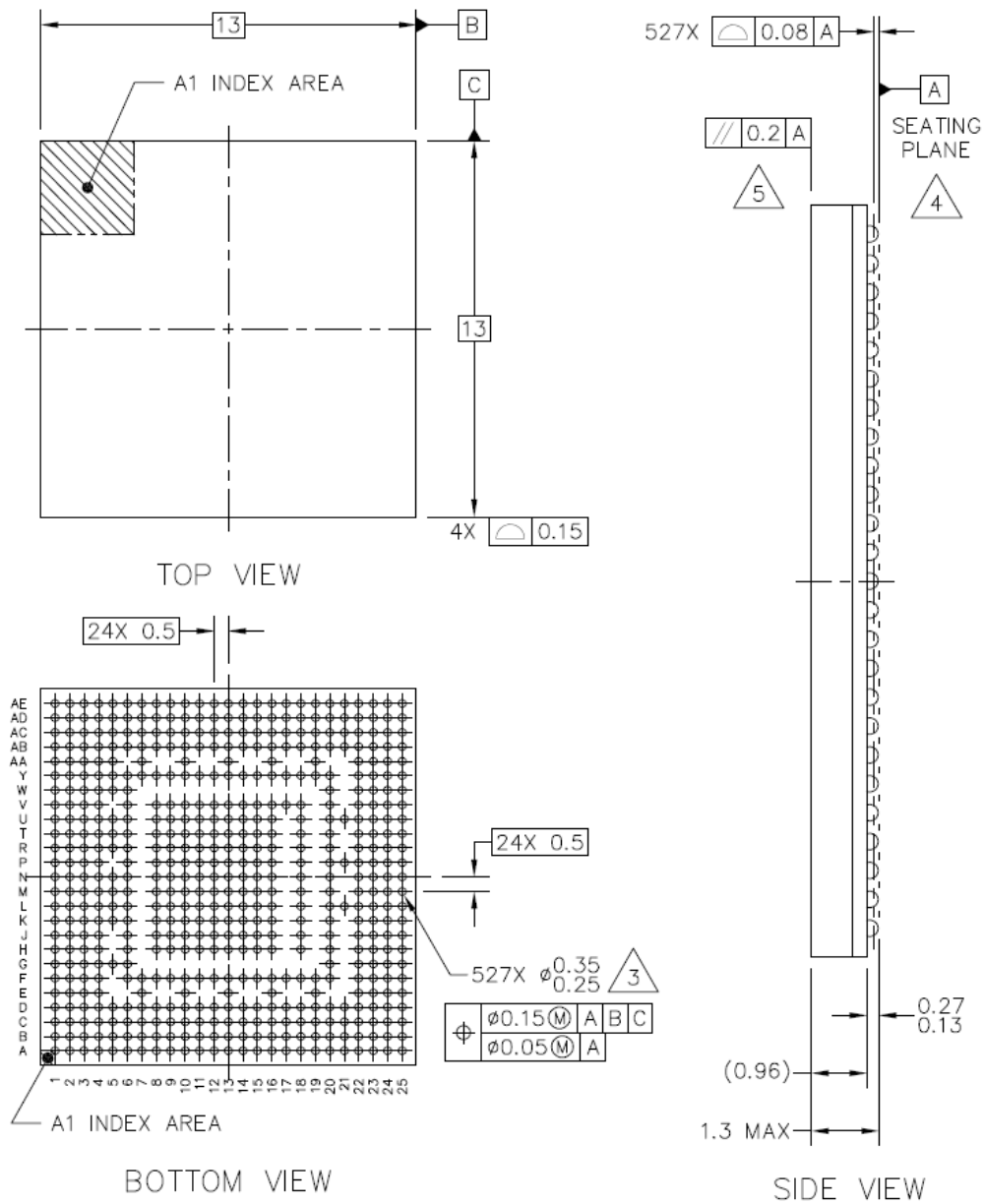

Figure 109. Package: Case 2058—0.5 mm Pitch

5.1.1.1 13 x 13 mm Package Drawing Notes

The following notes apply to Figure 109.

- 1 All dimensions in millimeters.
- 2 Dimensioning and tolerancing per ASME Y14.5M-1994.
- 3 Maximum solder ball diameter measured parallel to Datum A.

⁴ Datum A, the seating plane, is determined by the spherical crowns of the solder balls.

⁵ Parallelism measurement shall exclude any effect of mark on top surface of package.

5.1.2 13 x 13 mm, 0.5 Pitch Ball Assignment Lists

Table 127 shows the device connection list for ground, power, sense, and reference contact signals alpha-sorted by name. Table 128 displays an alpha-sorted list of the signal assignments. Table 129 provides a listing of the no-connect contacts.

5.1.2.1 13 x 13 mm Ball Contact Assignments

Table 127 shows the device connection list for ground, power, sense, and reference contact signals alpha-sorted by name.

Table 127. 13 x 13 mm Ground, Power, Sense, and Reference Contact Assignments

| Contact Name | Contact Assignment |
|---------------|---|
| AHVDDRGB | V15, V16 |
| AHVSSRGB | V13, V14 |
| GND | A1, A24, A25, B1, B25, E7, E13, E16, E19, G5, J13, J14, K5, K13, K14, K15, L13, L14, L15, L21, M12, M13, M14, M15, N5, N6, N8, N9, N10, N11, P8, P9, P11, P21, R8, R9, R10, R11, R12, T8, T9, T10, T11, T12, T13, U5, U9, U10, U11, U12, U13, U21, W5, AA7, AA10, AA13, AA16, AA19, AD1, AD2, AD25, AE1, AE24, AE25 |
| GND_ANA_PLL_A | AE3 |
| GND_ANA_PLL_B | AC25 |
| GND_DIG_PLL_A | AE2 |
| GND_DIG_PLL_B | AD24 |
| NGND_OSC | AC23 |
| NGND_TV_BACK | AB22 |
| NGND_USBPHY | L23 |
| NVCC_EMI | U8, V8 |
| NVCC_EMI_DRAM | L5, M5, R5, T5, Y5, AA5 |
| NVCC_HS10 | M20 |
| NVCC_HS4_1 | L20 |
| NVCC_HS4_2 | P20 |
| NVCC_HS6 | N20 |
| NVCC_I2C | V11 |
| NVCC_IPU2 | V20 |
| NVCC_IPU4 | N16 |
| NVCC_IPU5 | K16 |
| NVCC_IPU6 | M16 |

Table 127. 13 x 13 mm Ground, Power, Sense, and Reference Contact Assignments (continued)

| Contact Name | Contact Assignment |
|---------------|--|
| NVCC_IPU7 | H22 |
| NVCC_IPU8 | V22 |
| NVCC_IPU9 | L16 |
| NVCC_NANDF_A | J8 |
| NVCC_NANDF_B | H8 |
| NVCC_NANDF_C | H9 |
| NVCC_OSC | AD22 |
| NVCC_PER10 | H12 |
| NVCC_PER11 | H11 |
| NVCC_PER12 | H15 |
| NVCC_PER13 | H14 |
| NVCC_PER14 | V9 |
| NVCC_PER15 | H16 |
| NVCC_PER17 | J16 |
| NVCC_PER3 | V10 |
| NVCC_PER5 | D20 |
| NVCC_PER8 | J15 |
| NVCC_PER9 | H10 |
| NVCC_SRTC_POW | V12 |
| NVCC_TV_BACK | AC22 |
| NVCC_USBPHY | P16 |
| RREFEXT | K18 |
| SGND | P10 |
| SVCC | N13 |
| SVDDGP | M11 |
| TVDAC_DHVDD | AB21 |
| VBUS | L22 |
| VCC | N12, N14, N15, P12, P13, P14, P15, R13, R14, R15, T14, T15, T16, U14, U15, U16 |
| VDD_ANA_PLL_A | AD4 |
| VDD_ANA_PLL_B | AC24 |
| VDD_DIG_PLL_A | AD3 |
| VDD_DIG_PLL_B | AB23 |
| VDD_FUSE | P6 |

Table 127. 13 x 13 mm Ground, Power, Sense, and Reference Contact Assignments (continued)

| Contact Name | Contact Assignment |
|--------------|---|
| VDDA | H13, N18, R6, T6, Y16 |
| VDDA33 | R16 |
| VDDGP | E10, J9, J10, J11, J12, K8, K9, K10, K11, K12, L6, L8, L9, L10, L11, L12, M6, M8, M9, M10 |
| VREF | U6 |
| VREFOUT | AB20 |
| VREG | L24 |

5.1.2.2 13 x 13 mm Signal Assignments, Power Rails, and I/O

Table 128 shows signal assignment connect list including the associated power supplies. Table 132 lists the contacts that can be overridden with fuse settings.

Table 128. 13 x 13 mm Signal Assignments, Power Rails, and I/O

| Contact Name | Contact Assignment | Power Rail | I/O Buffer Type | Direction after Reset ¹ | Configuraton after Reset ¹ |
|-------------------|--------------------|---------------|-----------------|------------------------------------|---------------------------------------|
| AUD3_BB_CK | C9 | NVCC_PER9 | GPIO | Input | Keeper |
| AUD3_BB_FS | C8 | NVCC_PER9 | GPIO | Input | Keeper |
| AUD3_BB_RXD | B8 | NVCC_PER9 | GPIO | Input | Keeper |
| AUD3_BB_TXD | B7 | NVCC_PER9 | GPIO | Input | Keeper |
| BOOT_MODE0 | W22 | NVCC_PER3 | LVIO | Input | 100 k Ω pull-up |
| BOOT_MODE1 | AA24 | NVCC_PER3 | LVIO | Input | 100 k Ω pull-up |
| CKIH1 | AB24 | NVCC_PER3 | Analog | Input | Analog |
| CKIH2 | AA23 | NVCC_PER3 | Analog | Input | Analog |
| CKIL | AA22 | NVCC_SRTC_POW | GPIO | Input | Standard CMOS |
| CLK_SS | Y22 | NVCC_PER3 | LVIO | Input | 100 k Ω pull-up |
| COMP ² | AC20 | AHVDDRGB | Analog | Input | Analog |
| CSI1_D10 | R24 | NVCC_HS10 | HSGPIO | Input | Keeper |
| CSI1_D11 | R25 | NVCC_HS10 | HSGPIO | Input | Keeper |
| CSI1_D12 | P22 | NVCC_HS10 | HSGPIO | Input | Keeper |
| CSI1_D13 | P23 | NVCC_HS10 | HSGPIO | Input | Keeper |
| CSI1_D14 | P24 | NVCC_HS10 | HSGPIO | Input | Keeper |
| CSI1_D15 | P25 | NVCC_HS10 | HSGPIO | Input | Keeper |
| CSI1_D16 | N24 | NVCC_HS10 | HSGPIO | Input | Keeper |
| CSI1_D17 | N25 | NVCC_HS10 | HSGPIO | Input | Keeper |
| CSI1_D18 | N23 | NVCC_HS10 | HSGPIO | Input | Keeper |

Table 128. 13 x 13 mm Signal Assignments, Power Rails, and I/O (continued)

| Contact Name | Contact Assignment | Power Rail | I/O Buffer Type | Direction after Reset ¹ | Configuraton after Reset ¹ |
|--------------|--------------------|------------|-----------------|------------------------------------|---------------------------------------|
| CSI1_D19 | N22 | NVCC_HS10 | HSGPIO | Input | Keeper |
| CSI1_D8 | A20 | NVCC_PER8 | GPIO | Input | Keeper |
| CSI1_D9 | B20 | NVCC_PER8 | GPIO | Input | Keeper |
| CSI1_HSYNC | C19 | NVCC_PER8 | GPIO | Input | Keeper |
| CSI1_MCLK | F19 | NVCC_PER8 | GPIO | Input | Keeper |
| CSI1_PIXCLK | D19 | NVCC_PER8 | GPIO | Input | Keeper |
| CSI1_VSYNC | B19 | NVCC_PER8 | GPIO | Input | Keeper |
| CSI2_D12 | F11 | NVCC_PER9 | GPIO | Input | Keeper |
| CSI2_D13 | D8 | NVCC_PER9 | GPIO | Input | Keeper |
| CSI2_D14 | M25 | NVCC_HS4_1 | HSGPIO | Input | Keeper |
| CSI2_D15 | M24 | NVCC_HS4_1 | HSGPIO | Input | Keeper |
| CSI2_D16 | M23 | NVCC_HS4_1 | HSGPIO | Input | Keeper |
| CSI2_D17 | M22 | NVCC_HS4_1 | HSGPIO | Input | Keeper |
| CSI2_D18 | A7 | NVCC_PER9 | GPIO | Input | Keeper |
| CSI2_D19 | C7 | NVCC_PER9 | GPIO | Input | Keeper |
| CSI2_HSYNC | J20 | NVCC_PER8 | GPIO | Input | Keeper |
| CSI2_PIXCLK | D21 | NVCC_PER8 | GPIO | Input | Keeper |
| CSI2_VSYNC | C20 | NVCC_PER8 | GPIO | Input | Keeper |
| CSPI1_MISO | F12 | NVCC_PER10 | GPIO | Input | 100 k Ω pull-up |
| CSPI1_MOSI | D9 | NVCC_PER10 | GPIO | Input | 100 k Ω pull-up |
| CSPI1_RDY | A8 | NVCC_PER10 | GPIO | Input | Keeper |
| CSPI1_SCLK | D11 | NVCC_PER10 | GPIO | Input | 100 k Ω pull-up |
| CSPI1_SS0 | D10 | NVCC_PER10 | GPIO | Input | 100 k Ω pull-up |
| CSPI1_SS1 | F13 | NVCC_PER10 | GPIO | Input | 100 k Ω pull-up |
| DI_GP1 | F20 | NVCC_IPU6 | GPIO | Input | Keeper |
| DI_GP2 | K20 | NVCC_IPU6 | GPIO | Input | Keeper |
| DI_GP3 | H23 | NVCC_IPU7 | GPIO | Input | 100 k Ω pull-up |
| DI_GP4 | K23 | NVCC_IPU7 | GPIO | Input | 100 k Ω pull-up |
| DI1_D0_CS | W20 | NVCC_IPU2 | GPIO | Output | High |
| DI1_D1_CS | T18 | NVCC_IPU2 | GPIO | Output | High |
| DI1_DISP_CLK | J22 | NVCC_IPU6 | GPIO | Output | Low |
| DI1_PIN11 | V18 | NVCC_IPU2 | GPIO | Output | High |

Table 128. 13 x 13 mm Signal Assignments, Power Rails, and I/O (continued)

| Contact Name | Contact Assignment | Power Rail | I/O Buffer Type | Direction after Reset ¹ | Configuraton after Reset ¹ |
|--------------------------|--------------------|------------|-----------------|------------------------------------|---------------------------------------|
| DI1_PIN12 | W25 | NVCC_IPU2 | GPIO | Output | High |
| DI1_PIN13 | W24 | NVCC_IPU2 | GPIO | Output | High |
| DI1_PIN15 | G20 | NVCC_IPU6 | GPIO | Output | High |
| DI1_PIN2 | J18 | NVCC_IPU6 | GPIO | Output | High |
| DI1_PIN3 | H20 | NVCC_IPU6 | GPIO | Output | High |
| DI2_DISP_CLK | J24 | NVCC_IPU7 | GPIO | Output | High |
| DI2_PIN2 | H24 | NVCC_IPU7 | GPIO | Output | High |
| DI2_PIN3 | J25 | NVCC_IPU7 | GPIO | Output | High |
| DI2_PIN4 | J23 | NVCC_IPU7 | GPIO | Input | Keeper |
| DISP1_DAT0 | T23 | NVCC_HS6 | HSGPIO | Input | Keeper |
| DISP1_DAT1 | T22 | NVCC_HS6 | HSGPIO | Input | Keeper |
| DISP1_DAT10 ³ | E24 | NVCC_IPU4 | GPIO | Input | Keeper |
| DISP1_DAT11 ¹ | E25 | NVCC_IPU4 | GPIO | Input | Keeper |
| DISP1_DAT12 ¹ | E22 | NVCC_IPU4 | GPIO | Input | Keeper |
| DISP1_DAT13 ¹ | E23 | NVCC_IPU4 | GPIO | Input | Keeper |
| DISP1_DAT14 ¹ | D22 | NVCC_IPU4 | GPIO | Input | Keeper |
| DISP1_DAT15 ¹ | F22 | NVCC_IPU4 | GPIO | Input | Keeper |
| DISP1_DAT16 ¹ | F23 | NVCC_IPU5 | GPIO | Input | Keeper |
| DISP1_DAT17 ¹ | F24 | NVCC_IPU5 | GPIO | Input | Keeper |
| DISP1_DAT18 ¹ | G23 | NVCC_IPU5 | GPIO | Input | Keeper |
| DISP1_DAT19 ¹ | G22 | NVCC_IPU5 | GPIO | Input | Keeper |
| DISP1_DAT2 | T24 | NVCC_HS6 | HSGPIO | Input | Keeper |
| DISP1_DAT20 ¹ | G25 | NVCC_IPU5 | GPIO | Input | Keeper |
| DISP1_DAT21 ¹ | F25 | NVCC_IPU5 | GPIO | Input | Keeper |
| DISP1_DAT22 ¹ | G24 | NVCC_IPU5 | GPIO | Input | Keeper |
| DISP1_DAT23 ¹ | H25 | NVCC_IPU5 | GPIO | Input | Keeper |
| DISP1_DAT3 | T25 | NVCC_HS6 | HSGPIO | Input | Keeper |
| DISP1_DAT4 | R23 | NVCC_HS6 | HSGPIO | Input | Keeper |
| DISP1_DAT5 | R22 | NVCC_HS6 | HSGPIO | Input | Keeper |
| DISP1_DAT6 ¹ | D25 | NVCC_IPU4 | GPIO | Input | Keeper |
| DISP1_DAT7 ¹ | D24 | NVCC_IPU4 | GPIO | Input | Keeper |
| DISP1_DAT8 ¹ | C23 | NVCC_IPU4 | GPIO | Input | Keeper |

Table 128. 13 x 13 mm Signal Assignments, Power Rails, and I/O (continued)

| Contact Name | Contact Assignment | Power Rail | I/O Buffer Type | Direction after Reset ¹ | Configuraton after Reset ¹ |
|-------------------------|--------------------|---------------|-----------------|------------------------------------|---------------------------------------|
| DISP1_DAT9 ¹ | D23 | NVCC_IPU4 | GPIO | Input | Keeper |
| DISP2_DAT0 | T20 | NVCC_IPU8 | GPIO | Input | Keeper |
| DISP2_DAT1 | P18 | NVCC_IPU8 | GPIO | Input | Keeper |
| DISP2_DAT10 | R18 | NVCC_IPU9 | GPIO | Input | Keeper |
| DISP2_DAT11 | V24 | NVCC_IPU9 | GPIO | Input | Keeper |
| DISP2_DAT12 | M18 | NVCC_IPU9 | GPIO | Input | Keeper |
| DISP2_DAT13 | U18 | NVCC_IPU9 | GPIO | Input | Keeper |
| DISP2_DAT14 | U20 | NVCC_IPU9 | GPIO | Input | Keeper |
| DISP2_DAT15 | V23 | NVCC_IPU9 | GPIO | Input | Keeper |
| DISP2_DAT2 | U22 | NVCC_HS4_2 | HSGPIO | Input | Keeper |
| DISP2_DAT3 | U23 | NVCC_HS4_2 | HSGPIO | Input | Keeper |
| DISP2_DAT4 | U24 | NVCC_HS4_2 | HSGPIO | Input | Keeper |
| DISP2_DAT5 | U25 | NVCC_HS4_2 | HSGPIO | Input | Keeper |
| DISP2_DAT6 | R20 | NVCC_IPU8 | GPIO | Input | Keeper |
| DISP2_DAT7 | V25 | NVCC_IPU8 | GPIO | Input | Keeper |
| DISP2_DAT8 | L18 | NVCC_IPU9 | GPIO | Input | Keeper |
| DISP2_DAT9 | V17 | NVCC_IPU9 | GPIO | Input | Keeper |
| DISPB2_SER_CLK | Y25 | NVCC_IPU2 | GPIO | Output | High |
| DISPB2_SER_DIN | Y23 | NVCC_IPU2 | GPIO | Input | 100 kΩ pull-up |
| DISPB2_SER_DIO | Y20 | NVCC_IPU2 | GPIO | Input | 100 kΩ pull-up |
| DISPB2_SER_RS | W23 | NVCC_IPU2 | GPIO | Output | High |
| DN | K25 | VDDA33 | Analog | Output | — |
| DP | K24 | VDDA33 | Analog | Output | — |
| DRAM_A0 | V4 | NVCC_EMI_DRAM | DDR2 | Output | High |
| DRAM_A1 | V3 | NVCC_EMI_DRAM | DDR2 | Output | High |
| DRAM_A10 | T4 | NVCC_EMI_DRAM | DDR2 | Output | High |
| DRAM_A11 | R1 | NVCC_EMI_DRAM | DDR2 | Output | High |
| DRAM_A12 | P2 | NVCC_EMI_DRAM | DDR2 | Output | High |
| DRAM_A13 | R4 | NVCC_EMI_DRAM | DDR2 | Output | High |
| DRAM_A14 | R2 | NVCC_EMI_DRAM | DDR2 | Output | High |
| DRAM_A2 | U4 | NVCC_EMI_DRAM | DDR2 | Output | High |
| DRAM_A3 | U3 | NVCC_EMI_DRAM | DDR2 | Output | High |

Table 128. 13 x 13 mm Signal Assignments, Power Rails, and I/O (continued)

| Contact Name | Contact Assignment | Power Rail | I/O Buffer Type | Direction after Reset ¹ | Configuraton after Reset ¹ |
|--------------|--------------------|---------------|-----------------|------------------------------------|---------------------------------------|
| DRAM_A4 | U1 | NVCC_EMI_DRAM | DDR2 | Output | High |
| DRAM_A5 | U2 | NVCC_EMI_DRAM | DDR2 | Output | High |
| DRAM_A6 | T1 | NVCC_EMI_DRAM | DDR2 | Output | High |
| DRAM_A7 | T2 | NVCC_EMI_DRAM | DDR2 | Output | High |
| DRAM_A8 | T3 | NVCC_EMI_DRAM | DDR2 | Output | High |
| DRAM_A9 | P1 | NVCC_EMI_DRAM | DDR2 | Output | High |
| DRAM_CAS | N4 | NVCC_EMI_DRAM | DDR2 | Output | High |
| DRAM_CS0 | P3 | NVCC_EMI_DRAM | DDR2 | Output | High |
| DRAM_CS1 | R3 | NVCC_EMI_DRAM | DDR2 | Output | High |
| DRAM_D0 | AC4 | NVCC_EMI_DRAM | DDR2 | Output | High |
| DRAM_D1 | AC3 | NVCC_EMI_DRAM | DDR2 | Output | High |
| DRAM_D10 | AA2 | NVCC_EMI_DRAM | DDR2 | Output | High |
| DRAM_D11 | AA1 | NVCC_EMI_DRAM | DDR2 | Output | High |
| DRAM_D12 | AB2 | NVCC_EMI_DRAM | DDR2 | Output | High |
| DRAM_D13 | AB1 | NVCC_EMI_DRAM | DDR2 | Output | High |
| DRAM_D14 | AC2 | NVCC_EMI_DRAM | DDR2 | Output | High |
| DRAM_D15 | AC1 | NVCC_EMI_DRAM | DDR2 | Output | High |
| DRAM_D16 | F2 | NVCC_EMI_DRAM | DDR2 | Output | High |
| DRAM_D17 | F3 | NVCC_EMI_DRAM | DDR2 | Output | High |
| DRAM_D18 | G3 | NVCC_EMI_DRAM | DDR2 | Output | High |
| DRAM_D19 | F4 | NVCC_EMI_DRAM | DDR2 | Output | High |
| DRAM_D2 | AB3 | NVCC_EMI_DRAM | DDR2 | Output | High |
| DRAM_D20 | H3 | NVCC_EMI_DRAM | DDR2 | Output | High |
| DRAM_D21 | G4 | NVCC_EMI_DRAM | DDR2 | Output | High |
| DRAM_D22 | J3 | NVCC_EMI_DRAM | DDR2 | Output | High |
| DRAM_D23 | H4 | NVCC_EMI_DRAM | DDR2 | Output | High |
| DRAM_D24 | J4 | NVCC_EMI_DRAM | DDR2 | Output | High |
| DRAM_D25 | J1 | NVCC_EMI_DRAM | DDR2 | Output | High |
| DRAM_D26 | J2 | NVCC_EMI_DRAM | DDR2 | Output | High |
| DRAM_D27 | H1 | NVCC_EMI_DRAM | DDR2 | Output | High |
| DRAM_D28 | H2 | NVCC_EMI_DRAM | DDR2 | Output | High |
| DRAM_D29 | G1 | NVCC_EMI_DRAM | DDR2 | Output | High |

Table 128. 13 x 13 mm Signal Assignments, Power Rails, and I/O (continued)

| Contact Name | Contact Assignment | Power Rail | I/O Buffer Type | Direction after Reset ¹ | Configuraton after Reset ¹ |
|----------------------|--------------------|---------------|-----------------|------------------------------------|---------------------------------------|
| DRAM_D3 | AB4 | NVCC_EMI_DRAM | DDR2 | Output | High |
| DRAM_D30 | G2 | NVCC_EMI_DRAM | DDR2 | Output | High |
| DRAM_D31 | F1 | NVCC_EMI_DRAM | DDR2 | Output | High |
| DRAM_D4 | AA3 | NVCC_EMI_DRAM | DDR2 | Output | High |
| DRAM_D5 | AA4 | NVCC_EMI_DRAM | DDR2 | Output | High |
| DRAM_D6 | Y3 | NVCC_EMI_DRAM | DDR2 | Output | High |
| DRAM_D7 | Y4 | NVCC_EMI_DRAM | DDR2 | Output | High |
| DRAM_D8 | Y1 | NVCC_EMI_DRAM | DDR2 | Output | High |
| DRAM_D9 | Y2 | NVCC_EMI_DRAM | DDR2 | Output | High |
| DRAM_DQM0 | V1 | NVCC_EMI_DRAM | DDR2 | Output | High |
| DRAM_DQM1 | V2 | NVCC_EMI_DRAM | DDR2 | Output | High |
| DRAM_DQM2 | M4 | NVCC_EMI_DRAM | DDR2 | Output | High |
| DRAM_DQM3 | N2 | NVCC_EMI_DRAM | DDR2 | Output | High |
| DRAM_RAS | N3 | NVCC_EMI_DRAM | DDR2 | Output | High |
| DRAM_SDCKE0 | N1 | NVCC_EMI_DRAM | DDR2 | Output | High |
| DRAM_SDCKE1 | L1 | NVCC_EMI_DRAM | DDR2 | Output | High |
| DRAM_SDCLK | M1 | NVCC_EMI_DRAM | DDR2CLK | Output | High |
| DRAM_SDCLK_B | M2 | NVCC_EMI_DRAM | DDR2CLK | Output | High |
| DRAM_SDQS0 | W3 | NVCC_EMI_DRAM | DDR2CLK | Output | High |
| DRAM_SDQS0_B | W4 | NVCC_EMI_DRAM | DDR2CLK | Output | High |
| DRAM_SDQS1 | W2 | NVCC_EMI_DRAM | DDR2CLK | Output | High |
| DRAM_SDQS1_B | W1 | NVCC_EMI_DRAM | DDR2CLK | Output | High |
| DRAM_SDQS2 | K3 | NVCC_EMI_DRAM | DDR2CLK | Output | High |
| DRAM_SDQS2_B | K4 | NVCC_EMI_DRAM | DDR2CLK | Output | High |
| DRAM_SDQS3 | K2 | NVCC_EMI_DRAM | DDR2CLK | Output | High |
| DRAM_SDQS3_B | K1 | NVCC_EMI_DRAM | DDR2CLK | Output | High |
| DRAM_SDWE | M3 | NVCC_EMI_DRAM | DDR2 | Output | High |
| EIM_A16 ¹ | Y12 | NVCC_EMI | GPIO | Input | 100 kΩ pull-up |
| EIM_A17 ¹ | AE6 | NVCC_EMI | GPIO | Input | 100 kΩ pull-up |
| EIM_A18 ¹ | Y13 | NVCC_EMI | GPIO | Input | 100 kΩ pull-up |
| EIM_A19 ¹ | AE7 | NVCC_EMI | GPIO | Input | 100 kΩ pull-up |
| EIM_A20 ¹ | Y6 | NVCC_EMI | GPIO | Input | 100 kΩ pull-up |

Table 128. 13 x 13 mm Signal Assignments, Power Rails, and I/O (continued)

| Contact Name | Contact Assignment | Power Rail | I/O Buffer Type | Direction after Reset ¹ | Configuraton after Reset ¹ |
|----------------------|--------------------|------------|-----------------|------------------------------------|---------------------------------------|
| EIM_A21 ¹ | AD6 | NVCC_EMI | GPIO | Input | 100 kΩ pull-up |
| EIM_A22 | AB9 | NVCC_EMI | GPIO | Output | High |
| EIM_A23 ¹ | AE5 | NVCC_EMI | GPIO | Input | 100 kΩ pull-up |
| EIM_A24 | Y9 | NVCC_EMI | GPIO | Input | 100 kΩ pull-up |
| EIM_A25 | AD5 | NVCC_EMI | GPIO | Input | 100 kΩ pull-up |
| EIM_A26 | AB7 | NVCC_EMI | GPIO | Input | 100 kΩ pull-up |
| EIM_A27 | AC6 | NVCC_EMI | GPIO | Input | Keeper |
| EIM_BCLK | Y10 | NVCC_EMI | GPIO | Input | Keeper |
| EIM_CRE | V6 | NVCC_EMI | GPIO | Output | High |
| EIM_CS0 | Y17 | NVCC_EMI | GPIO | Output | High |
| EIM_CS1 | W6 | NVCC_EMI | GPIO | Output | High |
| EIM_CS2 | AE4 | NVCC_EMI | GPIO | Input | Keeper |
| EIM_CS3 | Y8 | NVCC_EMI | GPIO | Input | Keeper |
| EIM_CS4 | AC7 | NVCC_EMI | GPIO | Input | Keeper |
| EIM_CS5 | Y7 | NVCC_EMI | GPIO | Input | Keeper |
| EIM_D16 | AB12 | NVCC_EMI | GPIO | Input | Keeper |
| EIM_D17 | AE8 | NVCC_EMI | GPIO | Input | Keeper |
| EIM_D18 | AD9 | NVCC_EMI | GPIO | Input | Keeper |
| EIM_D19 | AC10 | NVCC_EMI | GPIO | Input | Keeper |
| EIM_D20 | AD10 | NVCC_EMI | GPIO | Input | Keeper |
| EIM_D21 | AE10 | NVCC_EMI | GPIO | Input | Keeper |
| EIM_D22 | AE11 | NVCC_EMI | GPIO | Input | Keeper |
| EIM_D23 | AB11 | NVCC_EMI | GPIO | Input | Keeper |
| EIM_D24 | AE9 | NVCC_EMI | GPIO | Input | Keeper |
| EIM_D25 | AC9 | NVCC_EMI | GPIO | Input | Keeper |
| EIM_D26 | AD8 | NVCC_EMI | GPIO | Input | Keeper |
| EIM_D27 | AB10 | NVCC_EMI | GPIO | Input | Keeper |
| EIM_D28 | Y11 | NVCC_EMI | GPIO | Input | Keeper |
| EIM_D29 | AD7 | NVCC_EMI | GPIO | Input | Keeper |
| EIM_D30 | AC8 | NVCC_EMI | GPIO | Input | Keeper |
| EIM_D31 | AB8 | NVCC_EMI | GPIO | Input | Keeper |
| EIM_DA0 | AE15 | NVCC_EMI | GPIO | Input | Keeper |

Table 128. 13 x 13 mm Signal Assignments, Power Rails, and I/O (continued)

| Contact Name | Contact Assignment | Power Rail | I/O Buffer Type | Direction after Reset ¹ | Configuraton after Reset ¹ |
|------------------------|--------------------|---------------|-----------------|------------------------------------|---------------------------------------|
| EIM_DA1 | AD15 | NVCC_EMI | GPIO | Input | Keeper |
| EIM_DA10 | AC13 | NVCC_EMI | GPIO | Input | Keeper |
| EIM_DA11 | AE12 | NVCC_EMI | GPIO | Input | Keeper |
| EIM_DA12 | AE13 | NVCC_EMI | GPIO | Input | Keeper |
| EIM_DA13 | AD12 | NVCC_EMI | GPIO | Input | Keeper |
| EIM_DA14 | AC12 | NVCC_EMI | GPIO | Input | Keeper |
| EIM_DA15 | AD11 | NVCC_EMI | GPIO | Input | Keeper |
| EIM_DA2 | AC15 | NVCC_EMI | GPIO | Input | Keeper |
| EIM_DA3 | AB16 | NVCC_EMI | GPIO | Input | Keeper |
| EIM_DA4 | AE16 | NVCC_EMI | GPIO | Input | Keeper |
| EIM_DA5 | Y18 | NVCC_EMI | GPIO | Input | Keeper |
| EIM_DA6 | AB15 | NVCC_EMI | GPIO | Input | Keeper |
| EIM_DA7 | AC14 | NVCC_EMI | GPIO | Input | Keeper |
| EIM_DA8 | AB14 | NVCC_EMI | GPIO | Input | Keeper |
| EIM_DA9 | AD13 | NVCC_EMI | GPIO | Input | Keeper |
| EIM_DTACK | AC5 | NVCC_EMI | GPIO | Input | 100 kΩ pull-up |
| EIM_EB0 | AD14 | NVCC_EMI | GPIO | Output | High |
| EIM_EB1 | AE14 | NVCC_EMI | GPIO | Output | High |
| EIM_EB2 | AB13 | NVCC_EMI | GPIO | Input | Keeper |
| EIM_EB3 | AC11 | NVCC_EMI | GPIO | Input | Keeper |
| EIM_LBA | AB5 | NVCC_EMI | GPIO | Output | High |
| EIM_OE | Y14 | NVCC_EMI | GPIO | Output | High |
| EIM_RW | Y15 | NVCC_EMI | GPIO | Output | High |
| EIM_SDBA0 | P4 | NVCC_EMI_DRAM | DDR2 | Output | High |
| EIM_SDBA1 | L4 | NVCC_EMI_DRAM | DDR2 | Output | High |
| EIM_SDBA2 | K6 | NVCC_EMI_DRAM | DDR2 | Output | High |
| EIM_SDOTD0 | L2 | NVCC_EMI_DRAM | DDR2 | Output | High |
| EIM_SDOTD1 | L3 | NVCC_EMI_DRAM | DDR2 | Output | High |
| EIM_WAIT | AB6 | NVCC_EMI | GPIO | Input | 100 kΩ pull-up |
| EXTAL ² | AD23 | NVCC_OSC | Analog | Input | — |
| FASTR_ANA ² | AE22 | NVCC_PER3 | — | Input | — |
| FASTR_DIG ² | AC21 | NVCC_PER3 | — | Input | — |

Table 128. 13 x 13 mm Signal Assignments, Power Rails, and I/O (continued)

| Contact Name | Contact Assignment | Power Rail | I/O Buffer Type | Direction after Reset ¹ | Configuraton after Reset ¹ |
|-----------------------|--------------------|--------------|-----------------|------------------------------------|---------------------------------------|
| GPANAIO ² | K22 | NVCC_USBPHY | Analog | Output | — |
| GPIO_NAND | C3 | NVCC_NANDF_A | UHVIO | Input | 100 kΩ pull-up |
| GPIO1_0 | H18 | NVCC_PER5 | GPIO | Input | Keeper |
| GPIO1_1 | C21 | NVCC_PER5 | GPIO | Input | Keeper |
| GPIO1_2 | B23 | NVCC_PER5 | GPIO | Input | Keeper |
| GPIO1_3 | A22 | NVCC_PER5 | GPIO | Input | Keeper |
| GPIO1_4 | B22 | NVCC_PER5 | GPIO | Input | Keeper |
| GPIO1_5 | C22 | NVCC_PER5 | GPIO | Input | Keeper |
| GPIO1_6 | B24 | NVCC_PER5 | GPIO | Input | Keeper |
| GPIO1_7 | A23 | NVCC_PER5 | GPIO | Input | Keeper |
| GPIO1_8 | C24 | NVCC_PER5 | GPIO | Input | Keeper |
| GPIO1_9 | C25 | NVCC_PER5 | GPIO | Input | Keeper |
| I2C1_CLK | AB19 | NVCC_I2C | I2CIO | Input | 47 kΩ pull-up |
| I2C1_DAT | Y19 | NVCC_I2C | I2CIO | Input | 47 kΩ pull-up |
| ID | L25 | NVCC_USBPHY | Analog | Input | Pull-up |
| IOB ² | AE21 | AHVDDRGB | Analog | Output | — |
| IOB_BACK ² | AD21 | — | Analog | Output | — |
| IOG ² | AE20 | AHVDDRGB | Analog | Output | — |
| IOG_BACK ² | AD20 | — | Analog | Output | — |
| IOR ² | AE19 | AHVDDRGB | Analog | Output | — |
| IOR_BACK ² | AD19 | — | Analog | Output | — |
| JTAG_DE_B | AC16 | NVCC_PER14 | GPIO | Input/ Open-drain output | 47 kΩ pull-up |
| JTAG_MOD | AD16 | NVCC_PER14 | GPIO | Input | 100 kΩ pull-up |
| JTAG_TCK | AD18 | NVCC_PER14 | GPIO | Input | 100 kΩ pull-down |
| JTAG_TDI | AB17 | NVCC_PER14 | GPIO | Input | 47 kΩ pull-up |
| JTAG_TDO | AD17 | NVCC_PER14 | GPIO | 3-state output | Keeper |
| JTAG_TMS | AC17 | NVCC_PER14 | GPIO | Input | 47 kΩ pull-up |
| JTAG_TRSTB | AE17 | NVCC_PER14 | GPIO | Input | 47 kΩ pull-up |
| KEY_COL0 | B16 | NVCC_PER13 | GPIO | Input | 100 kΩ pull-up |
| KEY_COL1 | C16 | NVCC_PER13 | GPIO | Input | 100 kΩ pull-up |

Table 128. 13 x 13 mm Signal Assignments, Power Rails, and I/O (continued)

| Contact Name | Contact Assignment | Power Rail | I/O Buffer Type | Direction after Reset ¹ | Configuraton after Reset ¹ |
|-----------------------|--------------------|--------------|-----------------|------------------------------------|---------------------------------------|
| KEY_COL2 | D16 | NVCC_PER13 | GPIO | Input | 100 kΩ pull-up |
| KEY_COL3 ⁴ | A16 | NVCC_PER13 | GPIO | Output | High |
| KEY_COL4 ⁴ | B17 | NVCC_PER13 | GPIO | Output | Low |
| KEY_COL5 ⁴ | A17 | NVCC_PER13 | GPIO | Output | Low |
| KEY_ROW0 | B15 | NVCC_PER13 | GPIO | Input | 100 kΩ pull-up |
| KEY_ROW1 | C15 | NVCC_PER13 | GPIO | Input | 100 kΩ pull-up |
| KEY_ROW2 | F15 | NVCC_PER13 | GPIO | Input | 100 kΩ pull-up |
| KEY_ROW3 | D15 | NVCC_PER13 | GPIO | Input | 100 kΩ pull-up |
| NANDF_ALE | E1 | NVCC_NANDF_A | UHVIO | Output | High |
| NANDF_CLE | E2 | NVCC_NANDF_A | UHVIO | Output | High |
| NANDF_CS0 | D4 | NVCC_NANDF_A | UHVIO | Output | High |
| NANDF_CS1 | D1 | NVCC_NANDF_A | UHVIO | Output | High |
| NANDF_CS2 | D5 | NVCC_NANDF_A | UHVIO | Output | High |
| NANDF_CS3 | B2 | NVCC_NANDF_A | UHVIO | Output | High |
| NANDF_CS4 | B3 | NVCC_NANDF_A | UHVIO | Output | Low |
| NANDF_CS5 | C4 | NVCC_NANDF_A | UHVIO | Output | Low |
| NANDF_CS6 | A2 | NVCC_NANDF_B | UHVIO | Output | Low |
| NANDF_CS7 | F7 | NVCC_NANDF_B | UHVIO | Output | Low |
| NANDF_D0 | D7 | NVCC_NANDF_C | UHVIO | Input | Keeper |
| NANDF_D1 | F9 | NVCC_NANDF_C | UHVIO | Input | Keeper |
| NANDF_D10 | C5 | NVCC_NANDF_B | UHVIO | Input | Keeper |
| NANDF_D11 | B4 | NVCC_NANDF_B | UHVIO | Input | Keeper |
| NANDF_D12 | A3 | NVCC_NANDF_B | UHVIO | Input | Keeper |
| NANDF_D13 | F10 | NVCC_NANDF_B | UHVIO | Input | Keeper |
| NANDF_D14 | E4 | NVCC_NANDF_B | UHVIO | Input | Keeper |
| NANDF_D15 | J6 | NVCC_NANDF_B | UHVIO | Input | Keeper |
| NANDF_D2 | C6 | NVCC_NANDF_C | UHVIO | Input | Keeper |
| NANDF_D3 | B5 | NVCC_NANDF_C | UHVIO | Input | Keeper |
| NANDF_D4 | B6 | NVCC_NANDF_C | UHVIO | Input | Keeper |
| NANDF_D5 | F8 | NVCC_NANDF_C | UHVIO | Input | Keeper |
| NANDF_D6 | A6 | NVCC_NANDF_C | UHVIO | Input | Keeper |
| NANDF_D7 | A5 | NVCC_NANDF_B | UHVIO | Input | Keeper |

Table 128. 13 x 13 mm Signal Assignments, Power Rails, and I/O (continued)

| Contact Name | Contact Assignment | Power Rail | I/O Buffer Type | Direction after Reset ¹ | Configuraton after Reset ¹ |
|---------------|--------------------|---------------|-----------------|------------------------------------|---------------------------------------|
| NANDF_D8 | A4 | NVCC_NANDF_B | UHVIO | Input | Keeper |
| NANDF_D9 | H6 | NVCC_NANDF_B | UHVIO | Input | Keeper |
| NANDF_RB0 | D2 | NVCC_NANDF_A | UHVIO | Input | 100 kΩ pull-up |
| NANDF_RB1 | C1 | NVCC_NANDF_A | UHVIO | Input | 100 kΩ pull-up |
| NANDF_RB2 | D3 | NVCC_NANDF_A | UHVIO | Input | 100 kΩ pull-up |
| NANDF_RB3 | C2 | NVCC_NANDF_A | UHVIO | Input | 100 kΩ pull-up |
| NANDF_RDY_INT | D6 | NVCC_NANDF_B | UHVIO | Input | 100 kΩ pull-up |
| NANDF_RE_B | F6 | NVCC_NANDF_A | UHVIO | Output | — |
| NANDF_WE_B | G6 | NVCC_NANDF_A | UHVIO | Output | — |
| NANDF_WP_B | E3 | NVCC_NANDF_A | UHVIO | Output | — |
| OWIRE_LINE | A15 | NVCC_PER12 | GPIO | Input | 100 kΩ pull-up |
| PMIC_INT_REQ | AC18 | NVCC_SRTC_POW | GPIO | Input | 100 kΩ pull-up |
| PMIC_ON_REQ | AE18 | NVCC_SRTC_POW | GPIO | Input | 100 kΩ pull-up |
| PMIC_RDY | AC19 | NVCC_SRTC_POW | GPIO | Input | 100 kΩ pull-up |
| PMIC_STBY_REQ | AB18 | NVCC_SRTC_POW | GPIO | Input | 100 kΩ pull-up |
| POR_B | Y24 | NVCC_PER3 | LVIO | Input | 100 kΩ pull-up |
| RESET_IN_B | AA25 | NVCC_PER3 | LVIO | Input | 100 kΩ pull-up |
| SD1_CLK | A18 | NVCC_PER15 | UHVIO | Output | — |
| SD1_CMD | C17 | NVCC_PER15 | UHVIO | Input | 47 kΩ pull-up |
| SD1_DATA0 | B18 | NVCC_PER15 | UHVIO | Input | 47 kΩ pull-up |
| SD1_DATA1 | D17 | NVCC_PER15 | UHVIO | Input | 47 kΩ pull-up |
| SD1_DATA2 | D18 | NVCC_PER15 | UHVIO | Input | 47 kΩ pull-up |
| SD1_DATA3 | C18 | NVCC_PER15 | UHVIO | Input | 360 kΩ pull-down |
| SD2_CLK | A19 | NVCC_PER17 | UHVIO | Output | — |
| SD2_CMD | F16 | NVCC_PER17 | UHVIO | Input | 47 kΩ pull-up |
| SD2_DATA0 | F18 | NVCC_PER17 | UHVIO | Input | 47 kΩ pull-up |
| SD2_DATA1 | B21 | NVCC_PER17 | UHVIO | Input | 47 kΩ pull-up |
| SD2_DATA2 | A21 | NVCC_PER17 | UHVIO | Input | 47 kΩ pull-up |
| SD2_DATA3 | F17 | NVCC_PER17 | UHVIO | Input | 360 kΩ pull-down |
| STR | D14 | NVCC_PER12 | — | — | — |

Table 128. 13 x 13 mm Signal Assignments, Power Rails, and I/O (continued)

| Contact Name | Contact Assignment | Power Rail | I/O Buffer Type | Direction after Reset ¹ | Configuraton after Reset ¹ |
|-------------------|--------------------|------------|-----------------|------------------------------------|---------------------------------------|
| TEST_MODE | AB25 | NVCC_PER3 | GPIO | Input | 100 kΩ pull-down |
| UART1_CTS | B13 | NVCC_PER12 | GPIO | Input | 100 kΩ pull-up |
| UART1_RTS | C13 | NVCC_PER12 | GPIO | Input | 100 kΩ pull-up |
| UART1_RXD | D13 | NVCC_PER12 | GPIO | Input | 100 kΩ pull-up |
| UART1_TXD | A12 | NVCC_PER12 | GPIO | Input | 100 kΩ pull-up |
| UART2_RXD | A13 | NVCC_PER12 | GPIO | Input | 100 kΩ pull-up |
| UART2_TXD | C14 | NVCC_PER12 | GPIO | Input | 100 kΩ pull-up |
| UART3_RXD | B14 | NVCC_PER12 | GPIO | Input | Keeper |
| UART3_TXD | A14 | NVCC_PER12 | GPIO | Input | Keeper |
| USBH1_CLK | C11 | NVCC_PER11 | GPIO | Input | Keeper |
| USBH1_DATA0 | B11 | NVCC_PER11 | GPIO | Input | Keeper |
| USBH1_DATA1 | A10 | NVCC_PER11 | GPIO | Input | Keeper |
| USBH1_DATA2 | A9 | NVCC_PER11 | GPIO | Input | Keeper |
| USBH1_DATA3 | C10 | NVCC_PER11 | GPIO | Input | Keeper |
| USBH1_DATA4 | B9 | NVCC_PER11 | GPIO | Input | Keeper |
| USBH1_DATA5 | F14 | NVCC_PER11 | GPIO | Input | Keeper |
| USBH1_DATA6 | C12 | NVCC_PER11 | GPIO | Input | Keeper |
| USBH1_DATA7 | B12 | NVCC_PER11 | GPIO | Input | Keeper |
| USBH1_DIR | B10 | NVCC_PER11 | GPIO | Input | Keeper |
| USBH1_NXT | D12 | NVCC_PER11 | GPIO | Input | Keeper |
| USBH1_STP | A11 | NVCC_PER11 | GPIO | Input | Keeper |
| XTAL ² | AE23 | NVCC_OSC | Analog | Output | — |

¹ The state immediately after reset and before ROM firmware or software has executed.

² See [Table 3 on page 12](#) for more information.

³ During power-on reset this port acts as input for fuse override signal. See [Table 132 on page 189](#) for more information.

⁴ During power-on reset this port acts as output for diagnostic signal. See [Table 132 on page 189](#) for more information.

5.1.2.3 13 x 13 mm No Connect Assignments

Table 129 shows the device No Connect assignment list.

Table 129. 13 x 13 mm No Connect Assignments

| Ball Status | Ball Assignments |
|-------------|------------------|
| NC | E5 |
| NC | E6 |
| NC | E8 |
| NC | E9 |
| NC | E11 |
| NC | E12 |
| NC | E14 |
| NC | E15 |
| NC | E17 |
| NC | E18 |
| NC | E20 |
| NC | E21 |
| NC | F5 |
| NC | F21 |
| NC | G7 |
| NC | G8 |
| NC | G9 |
| NC | G10 |
| NC | G11 |
| NC | G12 |
| NC | G13 |
| NC | G14 |
| NC | G15 |
| NC | G16 |
| NC | G17 |
| NC | G18 |
| NC | G19 |
| NC | G21 |
| NC | H5 |
| NC | H7 |

Table 129. 13 x 13 mm No Connect Assignments (continued)

| Ball Status | Ball Assignments |
|--------------------|-------------------------|
| NC | H17 |
| NC | H19 |
| NC | H21 |
| NC | J5 |
| NC | J7 |
| NC | J17 |
| NC | J19 |
| NC | J21 |
| NC | K7 |
| NC | K17 |
| NC | K19 |
| NC | K21 |
| NC | L7 |
| NC | L17 |
| NC | L19 |
| NC | M7 |
| NC | M17 |
| NC | M19 |
| NC | M21 |
| NC | N7 |
| NC | N17 |
| NC | N19 |
| NC | N21 |
| NC | P5 |
| NC | P7 |
| NC | P17 |
| NC | P19 |
| NC | R7 |
| NC | R17 |
| NC | R19 |
| NC | R21 |
| NC | T7 |
| NC | T17 |

Table 129. 13 x 13 mm No Connect Assignments (continued)

| Ball Status | Ball Assignments |
|-------------|------------------|
| NC | T19 |
| NC | T21 |
| NC | U7 |
| NC | U17 |
| NC | U19 |
| NC | V5 |
| NC | V7 |
| NC | V19 |
| NC | V21 |
| NC | W7 |
| NC | W8 |
| NC | W9 |
| NC | W10 |
| NC | W11 |
| NC | W12 |
| NC | W13 |
| NC | W14 |
| NC | W15 |
| NC | W16 |
| NC | W17 |
| NC | W18 |
| NC | W19 |
| NC | W21 |
| NC | Y21 |
| NC | AA6 |
| NC | AA8 |
| NC | AA9 |
| NC | AA11 |
| NC | AA12 |
| NC | AA14 |
| NC | AA15 |
| NC | AA17 |
| NC | AA18 |

Table 129. 13 x 13 mm No Connect Assignments (continued)

| Ball Status | Ball Assignments |
|-------------|------------------|
| NC | AA20 |
| NC | AA21 |

5.1.3 13 x 13 mm Ball Map

See [Section 5.3, “13 × 13 mm, 0.5 Pitch Ball Map.”](#)

5.2 19 x 19 mm Package Information

This section contains the outline drawing, signal assignment map, ground/power/reference ID (by ball grid location) for the 19 × 19 mm, 0.8 mm pitch package.

5.2.1 BGA—Case 2017, 19 x 19 mm, 0.8 mm Pitch

Figure 110 shows the top view, bottom view, and side view of the 19 × 19 mm package.

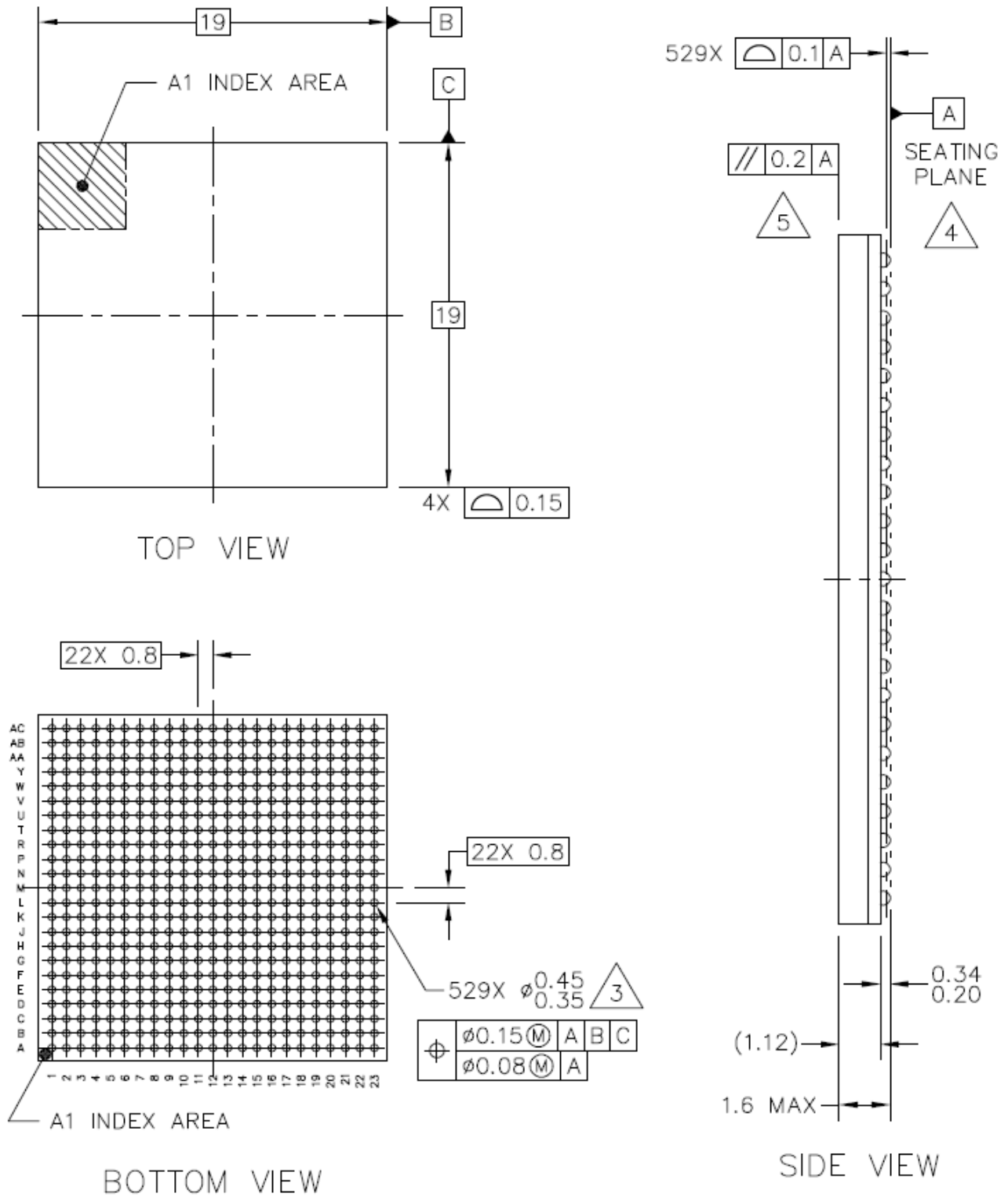

Figure 110. 19 x 19 mm Package: Case 2017-01—0.8 mm Pitch

5.2.1.1 19 x 19 mm Package Drawing Notes

The following notes apply to [Figure 110](#).

- ¹ All dimensions in millimeters.
- ² Dimensioning and tolerancing per ASME Y14.5M-1994.
- ³ Maximum solder ball diameter measured parallel to Datum A.
- ⁴ Datum A, the seating plane, is determined by the spherical crowns of the solder balls.
- ⁵ Parallelism measurement shall exclude any effect of mark on top surface of package.

5.2.2 19 x 19 mm Signal Assignments, Power Rails, and I/O

[Table 130](#) shows the device connection list and [Table 131](#) displays an alpha-sorted list of the signal assignments including associated power supplies.

5.2.2.1 19 x 19 mm Ground, Power, Sense, and Reference Contact Assignments

[Table 130](#) shows the device connection list for ground, power, sense, and reference contact signals alpha-sorted by name.

Table 130. 19 x 19 mm Ground, Power, Sense, and Reference Contact Assignments

| Contact Name | Contact Assignment |
|---------------|---|
| AHVDDRGB | Y18, AA18 |
| AHVSSRGB | Y19, AA19 |
| GND | A1, A23, G5, H9, J8, J9, J10, J12, J13, J14, K8, K9, K10, K11, K12, K13, K14, L8, L9, L10, L11, L12, L13, L14, M9, M10, M11, M12, M13, M14, M15, N8, N9, N10, N11, N12, N13, N14, N15, N16, P8, P9, P10, P11, P12, P13, P14, P15, R8, R9, R10, R11, R12, R13, R14, R15, R16, T5, T16, AC1, AC21, AC23 |
| GND_ANA_PLL_A | U7 |
| GND_ANA_PLL_B | U17 |
| GND_DIG_PLL_A | T7 |
| GND_DIG_PLL_B | V18 |
| NGND_OSC | V17 |
| NGND_TV_BACK | T15 |
| NGND_USBPHY | L16 |
| NVCC_EMI | U8, U9, U10, U11, U12, V7 |
| NVCC_EMI_DRAM | H6, J6, K6, L6, M6, N6, P6, R6, T6 |
| NVCC_HS10 | M16 |
| NVCC_HS4_1 | M18 |
| NVCC_HS4_2 | N18 |
| NVCC_HS6 | M17 |
| NVCC_I2C | T14 |

Table 130. 19 x 19 mm Ground, Power, Sense, and Reference Contact Assignments (continued)

| Contact Name | Contact Assignment |
|---------------|---|
| NVCC_IPU2 | T18 |
| NVCC_IPU4 | G16 |
| NVCC_IPU5 | H17 |
| NVCC_IPU6 | J17 |
| NVCC_IPU7 | K17 |
| NVCC_IPU8 | P18 |
| NVCC_IPU9 | R18 |
| NVCC_NANDF_A | E6, F5 |
| NVCC_NANDF_B | G9 |
| NVCC_NANDF_C | G10 |
| NVCC_OSC | W17 |
| NVCC_PER3 | U18 |
| NVCC_PER5 | G15 |
| NVCC_PER8 | H16 |
| NVCC_PER9 | H10 |
| NVCC_PER10 | H11 |
| NVCC_PER11 | G11 |
| NVCC_PER12 | G12 |
| NVCC_PER13 | G13 |
| NVCC_PER14 | U13 |
| NVCC_PER15 | H15 |
| NVCC_PER17 | G14 |
| NVCC_SRTC_POW | U14 |
| NVCC_TV_BACK | U16 |
| NVCC_USBPHY | L17 |
| RREFEXT | K19 |
| SGND | J11 |
| SVCC | H14 |
| SVDDGP | F13 |
| TVDAC_DHVDD | V16 |
| VBUS | K20 |
| VCC | H13, J15, J16, K15, K16, L7, L15, M7, N7, N17, P7, P17, R17, T8, T9, T10, T11, T12, T17 |
| VDD_ANA_PLL_A | V6 |

Table 130. 19 x 19 mm Ground, Power, Sense, and Reference Contact Assignments (continued)

| Contact Name | Contact Assignment |
|---------------|---|
| VDD_ANA_PLL_B | W19 |
| VDD_DIG_PLL_A | U6 |
| VDD_DIG_PLL_B | W18 |
| VDD_FUSE | R7 |
| VDDA | G8, H8, H12, M8, P16, T13 |
| VDDA33 | L18 |
| VDDGP | F6, F7, F8, F9, F10, F11, F12, G6, G7, H7, J7, K7 |
| VREFOUT | U15 |
| VREF | R5 |
| VREG | K21 |

5.2.2.2 19 x 19 mm, Signal Assignments, Power Rails, and I/O

Table 131 displays an alpha-sorted list of the signal assignments including power rails.

Table 131. 19 x 19 mm Signal Assignments, Power Rails, and I/O

| Contact Name | Contact Assignment | Power Rail | I/O Buffer Type | Direction after Reset ¹ | Configuraton after Reset ¹ |
|-------------------|--------------------|---------------|-----------------|------------------------------------|---------------------------------------|
| AUD3_BB_CK | C8 | NVCC_PER9 | GPIO | Input | Keeper |
| AUD3_BB_FS | A9 | NVCC_PER9 | GPIO | Input | Keeper |
| AUD3_BB_RXD | B9 | NVCC_PER9 | GPIO | Input | Keeper |
| AUD3_BB_TXD | E9 | NVCC_PER9 | GPIO | Input | Keeper |
| BOOT_MODE0 | AB21 | NVCC_PER3 | LVIO | Input | 100 k Ω pull-up |
| BOOT_MODE1 | AB22 | NVCC_PER3 | LVIO | Input | 100 k Ω pull-up |
| CKIH1 | V19 | NVCC_PER3 | Analog | Input | Analog |
| CKIH2 | AA20 | NVCC_PER3 | Analog | Input | Analog |
| CKIL | Y16 | NVCC_SRTC_POW | GPIO | Input | Standard CMOS |
| CLK_SS | AA21 | NVCC_PER3 | LVIO | Input | 100 k Ω pull-up |
| COMP ² | Y17 | AHVDDRGB | Analog | Input | Analog |
| CSI1_D10 | R22 | NVCC_HS10 | HSGPIO | Input | Keeper |
| CSI1_D11 | R23 | NVCC_HS10 | HSGPIO | Input | Keeper |
| CSI1_D12 | P22 | NVCC_HS10 | HSGPIO | Input | Keeper |
| CSI1_D13 | P23 | NVCC_HS10 | HSGPIO | Input | Keeper |
| CSI1_D14 | M20 | NVCC_HS10 | HSGPIO | Input | Keeper |

Table 131. 19 x 19 mm Signal Assignments, Power Rails, and I/O (continued)

| Contact Name | Contact Assignment | Power Rail | I/O Buffer Type | Direction after Reset ¹ | Configuraton after Reset ¹ |
|--------------|--------------------|------------|-----------------|------------------------------------|---------------------------------------|
| CSI1_D15 | M21 | NVCC_HS10 | HSGPIO | Input | Keeper |
| CSI1_D16 | N22 | NVCC_HS10 | HSGPIO | Input | Keeper |
| CSI1_D17 | N23 | NVCC_HS10 | HSGPIO | Input | Keeper |
| CSI1_D18 | M22 | NVCC_HS10 | HSGPIO | Input | Keeper |
| CSI1_D19 | M23 | NVCC_HS10 | HSGPIO | Input | Keeper |
| CSI1_D8 | E18 | NVCC_PER8 | GPIO | Input | Keeper |
| CSI1_D9 | A21 | NVCC_PER8 | GPIO | Input | Keeper |
| CSI1_HSYNC | A20 | NVCC_PER8 | GPIO | Input | Keeper |
| CSI1_MCLK | B20 | NVCC_PER8 | GPIO | Input | Keeper |
| CSI1_PIXCLK | F18 | NVCC_PER8 | GPIO | Input | Keeper |
| CSI1_VSYNC | G18 | NVCC_PER8 | GPIO | Input | Keeper |
| CSI2_D12 | B8 | NVCC_PER9 | GPIO | Input | Keeper |
| CSI2_D13 | C7 | NVCC_PER9 | GPIO | Input | Keeper |
| CSI2_D14 | L20 | NVCC_HS4_1 | HSGPIO | Input | Keeper |
| CSI2_D15 | L21 | NVCC_HS4_1 | HSGPIO | Input | Keeper |
| CSI2_D16 | L22 | NVCC_HS4_1 | HSGPIO | Input | Keeper |
| CSI2_D17 | L23 | NVCC_HS4_1 | HSGPIO | Input | Keeper |
| CSI2_D18 | D9 | NVCC_PER9 | GPIO | Input | Keeper |
| CSI2_D19 | A8 | NVCC_PER9 | GPIO | Input | Keeper |
| CSI2_HSYNC | C18 | NVCC_PER8 | GPIO | Input | Keeper |
| CSI2_PIXCLK | E19 | NVCC_PER8 | GPIO | Input | Keeper |
| CSI2_VSYNC | F19 | NVCC_PER8 | GPIO | Input | Keeper |
| CSPI1_MISO | C10 | NVCC_PER10 | GPIO | Input | 100 kΩ pull-up |
| CSPI1_MOSI | D10 | NVCC_PER10 | GPIO | Input | 100 kΩ pull-up |
| CSPI1_RDY | C9 | NVCC_PER10 | GPIO | Input | Keeper |
| CSPI1_SCLK | A10 | NVCC_PER10 | GPIO | Input | 100 kΩ pull-up |
| CSPI1_SS0 | E10 | NVCC_PER10 | GPIO | Input | 100 kΩ pull-up |
| CSPI1_SS1 | B10 | NVCC_PER10 | GPIO | Input | 100 kΩ pull-up |
| DI_GP1 | H21 | NVCC_IPU6 | GPIO | Input | Keeper |
| DI_GP2 | J19 | NVCC_IPU6 | GPIO | Input | Keeper |
| DI_GP3 | H22 | NVCC_IPU7 | GPIO | Input | 100 kΩ pull-up |
| DI_GP4 | J22 | NVCC_IPU7 | GPIO | Input | 100 kΩ pull-up |

Table 131. 19 x 19 mm Signal Assignments, Power Rails, and I/O (continued)

| Contact Name | Contact Assignment | Power Rail | I/O Buffer Type | Direction after Reset ¹ | Configuraton after Reset ¹ |
|--------------------------|--------------------|------------|-----------------|------------------------------------|---------------------------------------|
| DI1_D0_CS | U21 | NVCC_IPU2 | GPIO | Output | High |
| DI1_D1_CS | AB23 | NVCC_IPU2 | GPIO | Output | High |
| DI1_DISP_CLK | J18 | NVCC_IPU6 | GPIO | Output | Low |
| DI1_PIN11 | Y22 | NVCC_IPU2 | GPIO | Output | High |
| DI1_PIN12 | AA22 | NVCC_IPU2 | GPIO | Output | High |
| DI1_PIN13 | T20 | NVCC_IPU2 | GPIO | Output | High |
| DI1_PIN15 | H20 | NVCC_IPU6 | GPIO | Output | High |
| DI1_PIN2 | G23 | NVCC_IPU6 | GPIO | Output | High |
| DI1_PIN3 | G22 | NVCC_IPU6 | GPIO | Output | High |
| DI2_DISP_CLK | J21 | NVCC_IPU7 | GPIO | Output | High |
| DI2_PIN2 | J20 | NVCC_IPU7 | GPIO | Output | High |
| DI2_PIN3 | K18 | NVCC_IPU7 | GPIO | Output | High |
| DI2_PIN4 | H23 | NVCC_IPU7 | GPIO | Input | Keeper |
| DISP1_DAT0 | N20 | NVCC_HS6 | HSGPIO | Input | Keeper |
| DISP1_DAT1 | N21 | NVCC_HS6 | HSGPIO | Input | Keeper |
| DISP1_DAT10 ³ | D22 | NVCC_IPU4 | GPIO | Input | Keeper |
| DISP1_DAT11 ³ | D23 | NVCC_IPU4 | GPIO | Input | Keeper |
| DISP1_DAT12 ³ | E21 | NVCC_IPU4 | GPIO | Input | Keeper |
| DISP1_DAT13 ³ | F20 | NVCC_IPU4 | GPIO | Input | Keeper |
| DISP1_DAT14 ³ | E22 | NVCC_IPU4 | GPIO | Input | Keeper |
| DISP1_DAT15 ³ | G19 | NVCC_IPU4 | GPIO | Input | Keeper |
| DISP1_DAT16 ³ | E23 | NVCC_IPU5 | GPIO | Input | Keeper |
| DISP1_DAT17 ³ | F21 | NVCC_IPU5 | GPIO | Input | Keeper |
| DISP1_DAT18 ³ | G20 | NVCC_IPU5 | GPIO | Input | Keeper |
| DISP1_DAT19 ³ | H18 | NVCC_IPU5 | GPIO | Input | Keeper |
| DISP1_DAT2 | U22 | NVCC_HS6 | HSGPIO | Input | Keeper |
| DISP1_DAT20 ³ | F23 | NVCC_IPU5 | GPIO | Input | Keeper |
| DISP1_DAT21 ³ | H19 | NVCC_IPU5 | GPIO | Input | Keeper |
| DISP1_DAT22 ³ | F22 | NVCC_IPU5 | GPIO | Input | Keeper |
| DISP1_DAT23 ³ | G21 | NVCC_IPU5 | GPIO | Input | Keeper |
| DISP1_DAT3 | U23 | NVCC_HS6 | HSGPIO | Input | Keeper |
| DISP1_DAT4 | T22 | NVCC_HS6 | HSGPIO | Input | Keeper |

Table 131. 19 x 19 mm Signal Assignments, Power Rails, and I/O (continued)

| Contact Name | Contact Assignment | Power Rail | I/O Buffer Type | Direction after Reset ¹ | Configuraton after Reset ¹ |
|-------------------------|--------------------|---------------|-----------------|------------------------------------|---------------------------------------|
| DISP1_DAT5 | T23 | NVCC_HS6 | HSGPIO | Input | Keeper |
| DISP1_DAT6 ³ | C22 | NVCC_IPU4 | GPIO | Input | Keeper |
| DISP1_DAT7 ³ | C23 | NVCC_IPU4 | GPIO | Input | Keeper |
| DISP1_DAT8 ³ | D21 | NVCC_IPU4 | GPIO | Input | Keeper |
| DISP1_DAT9 ³ | E20 | NVCC_IPU4 | GPIO | Input | Keeper |
| DISP2_DAT0 | R21 | NVCC_IPU8 | GPIO | Input | Keeper |
| DISP2_DAT1 | M19 | NVCC_IPU8 | GPIO | Input | Keeper |
| DISP2_DAT10 | W22 | NVCC_IPU9 | GPIO | Input | Keeper |
| DISP2_DAT11 | R19 | NVCC_IPU9 | GPIO | Input | Keeper |
| DISP2_DAT12 | Y23 | NVCC_IPU9 | GPIO | Input | Keeper |
| DISP2_DAT13 | T19 | NVCC_IPU9 | GPIO | Input | Keeper |
| DISP2_DAT14 | AA23 | NVCC_IPU9 | GPIO | Input | Keeper |
| DISP2_DAT15 | T21 | NVCC_IPU9 | GPIO | Input | Keeper |
| DISP2_DAT2 | P20 | NVCC_HS4_2 | HSGPIO | Input | Keeper |
| DISP2_DAT3 | P21 | NVCC_HS4_2 | HSGPIO | Input | Keeper |
| DISP2_DAT4 | V22 | NVCC_HS4_2 | HSGPIO | Input | Keeper |
| DISP2_DAT5 | V23 | NVCC_HS4_2 | HSGPIO | Input | Keeper |
| DISP2_DAT6 | N19 | NVCC_IPU8 | GPIO | Input | Keeper |
| DISP2_DAT7 | W23 | NVCC_IPU8 | GPIO | Input | Keeper |
| DISP2_DAT8 | P19 | NVCC_IPU9 | GPIO | Input | Keeper |
| DISP2_DAT9 | R20 | NVCC_IPU9 | GPIO | Input | Keeper |
| DISPB2_SER_CLK | AC22 | NVCC_IPU2 | GPIO | Output | High |
| DISPB2_SER_DIN | U19 | NVCC_IPU2 | GPIO | Input | 100 kΩ pull-up |
| DISPB2_SER_DIO | V21 | NVCC_IPU2 | GPIO | Input | 100 kΩ pull-up |
| DISPB2_SER_RS | W21 | NVCC_IPU2 | GPIO | Output | High |
| DN | K22 | VDDA33 | Analog | Output | – |
| DP | K23 | VDDA33 | Analog | Output | – |
| DRAM_A0 | AB1 | NVCC_EMI_DRAM | DDR2 | Output | High |
| DRAM_A1 | AA2 | NVCC_EMI_DRAM | DDR2 | Output | High |
| DRAM_A10 | V2 | NVCC_EMI_DRAM | DDR2 | Output | High |
| DRAM_A11 | U4 | NVCC_EMI_DRAM | DDR2 | Output | High |
| DRAM_A12 | U2 | NVCC_EMI_DRAM | DDR2 | Output | High |

Table 131. 19 x 19 mm Signal Assignments, Power Rails, and I/O (continued)

| Contact Name | Contact Assignment | Power Rail | I/O Buffer Type | Direction after Reset ¹ | Configuraton after Reset ¹ |
|--------------|--------------------|---------------|-----------------|------------------------------------|---------------------------------------|
| DRAM_A13 | U1 | NVCC_EMI_DRAM | DDR2 | Output | High |
| DRAM_A14 | T2 | NVCC_EMI_DRAM | DDR2 | Output | High |
| DRAM_A2 | AA3 | NVCC_EMI_DRAM | DDR2 | Output | High |
| DRAM_A3 | V5 | NVCC_EMI_DRAM | DDR2 | Output | High |
| DRAM_A4 | W4 | NVCC_EMI_DRAM | DDR2 | Output | High |
| DRAM_A5 | Y2 | NVCC_EMI_DRAM | DDR2 | Output | High |
| DRAM_A6 | W3 | NVCC_EMI_DRAM | DDR2 | Output | High |
| DRAM_A7 | Y1 | NVCC_EMI_DRAM | DDR2 | Output | High |
| DRAM_A8 | W2 | NVCC_EMI_DRAM | DDR2 | Output | High |
| DRAM_A9 | V3 | NVCC_EMI_DRAM | DDR2 | Output | High |
| DRAM_CAS | V4 | NVCC_EMI_DRAM | DDR2 | Output | High |
| DRAM_CS0 | Y4 | NVCC_EMI_DRAM | DDR2 | Output | High |
| DRAM_CS1 | Y3 | NVCC_EMI_DRAM | DDR2 | Output | High |
| DRAM_D0 | T1 | NVCC_EMI_DRAM | DDR2 | Output | High |
| DRAM_D1 | R3 | NVCC_EMI_DRAM | DDR2 | Output | High |
| DRAM_D10 | M3 | NVCC_EMI_DRAM | DDR2 | Output | High |
| DRAM_D11 | M4 | NVCC_EMI_DRAM | DDR2 | Output | High |
| DRAM_D12 | M1 | NVCC_EMI_DRAM | DDR2 | Output | High |
| DRAM_D13 | M5 | NVCC_EMI_DRAM | DDR2 | Output | High |
| DRAM_D14 | L5 | NVCC_EMI_DRAM | DDR2 | Output | High |
| DRAM_D15 | L4 | NVCC_EMI_DRAM | DDR2 | Output | High |
| DRAM_D16 | L3 | NVCC_EMI_DRAM | DDR2 | Output | High |
| DRAM_D17 | L2 | NVCC_EMI_DRAM | DDR2 | Output | High |
| DRAM_D18 | L1 | NVCC_EMI_DRAM | DDR2 | Output | High |
| DRAM_D19 | K1 | NVCC_EMI_DRAM | DDR2 | Output | High |
| DRAM_D2 | R2 | NVCC_EMI_DRAM | DDR2 | Output | High |
| DRAM_D20 | K3 | NVCC_EMI_DRAM | DDR2 | Output | High |
| DRAM_D21 | K4 | NVCC_EMI_DRAM | DDR2 | Output | High |
| DRAM_D22 | J3 | NVCC_EMI_DRAM | DDR2 | Output | High |
| DRAM_D23 | J4 | NVCC_EMI_DRAM | DDR2 | Output | High |
| DRAM_D24 | K5 | NVCC_EMI_DRAM | DDR2 | Output | High |
| DRAM_D25 | H1 | NVCC_EMI_DRAM | DDR2 | Output | High |

Table 131. 19 x 19 mm Signal Assignments, Power Rails, and I/O (continued)

| Contact Name | Contact Assignment | Power Rail | I/O Buffer Type | Direction after Reset ¹ | Configuraton after Reset ¹ |
|----------------------|--------------------|---------------|-----------------|------------------------------------|---------------------------------------|
| DRAM_D26 | H2 | NVCC_EMI_DRAM | DDR2 | Output | High |
| DRAM_D27 | J5 | NVCC_EMI_DRAM | DDR2 | Output | High |
| DRAM_D28 | G1 | NVCC_EMI_DRAM | DDR2 | Output | High |
| DRAM_D29 | G2 | NVCC_EMI_DRAM | DDR2 | Output | High |
| DRAM_D3 | R1 | NVCC_EMI_DRAM | DDR2 | Output | High |
| DRAM_D30 | G3 | NVCC_EMI_DRAM | DDR2 | Output | High |
| DRAM_D31 | G4 | NVCC_EMI_DRAM | DDR2 | Output | High |
| DRAM_D4 | R4 | NVCC_EMI_DRAM | DDR2 | Output | High |
| DRAM_D5 | P5 | NVCC_EMI_DRAM | DDR2 | Output | High |
| DRAM_D6 | P4 | NVCC_EMI_DRAM | DDR2 | Output | High |
| DRAM_D7 | N5 | NVCC_EMI_DRAM | DDR2 | Output | High |
| DRAM_D8 | N2 | NVCC_EMI_DRAM | DDR2 | Output | High |
| DRAM_D9 | N1 | NVCC_EMI_DRAM | DDR2 | Output | High |
| DRAM_DQM0 | P3 | NVCC_EMI_DRAM | DDR2 | Output | High |
| DRAM_DQM1 | M2 | NVCC_EMI_DRAM | DDR2 | Output | High |
| DRAM_DQM2 | K2 | NVCC_EMI_DRAM | DDR2 | Output | High |
| DRAM_DQM3 | H5 | NVCC_EMI_DRAM | DDR2 | Output | High |
| DRAM_RAS | W1 | NVCC_EMI_DRAM | DDR2 | Output | High |
| DRAM_SDCKE0 | AA1 | NVCC_EMI_DRAM | DDR2 | Output | High |
| DRAM_SDCKE1 | W5 | NVCC_EMI_DRAM | DDR2 | Output | High |
| DRAM_SDCLK | T3 | NVCC_EMI_DRAM | DDR2CLK | Output | High |
| DRAM_SDCLK_B | T4 | NVCC_EMI_DRAM | DDR2CLK | Output | High |
| DRAM_SDQS0 | P2 | NVCC_EMI_DRAM | DDR2CLK | Output | High |
| DRAM_SDQS0_B | P1 | NVCC_EMI_DRAM | DDR2CLK | Output | High |
| DRAM_SDQS1 | N4 | NVCC_EMI_DRAM | DDR2CLK | Output | High |
| DRAM_SDQS1_B | N3 | NVCC_EMI_DRAM | DDR2CLK | Output | High |
| DRAM_SDQS2 | J1 | NVCC_EMI_DRAM | DDR2CLK | Output | High |
| DRAM_SDQS2_B | J2 | NVCC_EMI_DRAM | DDR2CLK | Output | High |
| DRAM_SDQS3 | H3 | NVCC_EMI_DRAM | DDR2CLK | Output | High |
| DRAM_SDQS3_B | H4 | NVCC_EMI_DRAM | DDR2CLK | Output | High |
| DRAM_SDWE | U5 | NVCC_EMI_DRAM | DDR2 | Output | High |
| EIM_A16 ³ | AA9 | NVCC_EMI | GPIO | Input | 100 kΩ pull-up |

Table 131. 19 x 19 mm Signal Assignments, Power Rails, and I/O (continued)

| Contact Name | Contact Assignment | Power Rail | I/O Buffer Type | Direction after Reset ¹ | Configuraton after Reset ¹ |
|----------------------|--------------------|------------|-----------------|------------------------------------|---------------------------------------|
| EIM_A17 ³ | AB9 | NVCC_EMI | GPIO | Input | 100 kΩ pull-up |
| EIM_A18 ³ | AC8 | NVCC_EMI | GPIO | Input | 100 kΩ pull-up |
| EIM_A19 ³ | AA8 | NVCC_EMI | GPIO | Input | 100 kΩ pull-up |
| EIM_A20 ³ | AB8 | NVCC_EMI | GPIO | Input | 100 kΩ pull-up |
| EIM_A21 ³ | AC7 | NVCC_EMI | GPIO | Input | 100 kΩ pull-up |
| EIM_A22 | AB7 | NVCC_EMI | GPIO | Output | High |
| EIM_A23 ³ | AC6 | NVCC_EMI | GPIO | Input | 100 kΩ pull-up |
| EIM_A24 | AC5 | NVCC_EMI | GPIO | Input | 100 kΩ pull-up |
| EIM_A25 | AB6 | NVCC_EMI | GPIO | Input | 100 kΩ pull-up |
| EIM_A26 | AC4 | NVCC_EMI | GPIO | Input | 100 kΩ pull-up |
| EIM_A27 | AB5 | NVCC_EMI | GPIO | Input | Keeper |
| EIM_BCLK | AA4 | NVCC_EMI | GPIO | Input | Keeper |
| EIM_CRE | AB2 | NVCC_EMI | GPIO | Output | High |
| EIM_CS0 | W6 | NVCC_EMI | GPIO | Output | High |
| EIM_CS1 | Y6 | NVCC_EMI | GPIO | Output | High |
| EIM_CS2 | Y7 | NVCC_EMI | GPIO | Input | Keeper |
| EIM_CS3 | AC3 | NVCC_EMI | GPIO | Input | Keeper |
| EIM_CS4 | AA6 | NVCC_EMI | GPIO | Input | Keeper |
| EIM_CS5 | AA5 | NVCC_EMI | GPIO | Input | Keeper |
| EIM_D16 | AC12 | NVCC_EMI | GPIO | Input | Keeper |
| EIM_D17 | W10 | NVCC_EMI | GPIO | Input | Keeper |
| EIM_D18 | AA11 | NVCC_EMI | GPIO | Input | Keeper |
| EIM_D19 | Y10 | NVCC_EMI | GPIO | Input | Keeper |
| EIM_D20 | AB11 | NVCC_EMI | GPIO | Input | Keeper |
| EIM_D21 | W9 | NVCC_EMI | GPIO | Input | Keeper |
| EIM_D22 | AC11 | NVCC_EMI | GPIO | Input | Keeper |
| EIM_D23 | V8 | NVCC_EMI | GPIO | Input | Keeper |
| EIM_D24 | AA10 | NVCC_EMI | GPIO | Input | Keeper |
| EIM_D25 | Y9 | NVCC_EMI | GPIO | Input | Keeper |
| EIM_D26 | AB10 | NVCC_EMI | GPIO | Input | Keeper |
| EIM_D27 | W8 | NVCC_EMI | GPIO | Input | Keeper |
| EIM_D28 | AC10 | NVCC_EMI | GPIO | Input | Keeper |

Table 131. 19 x 19 mm Signal Assignments, Power Rails, and I/O (continued)

| Contact Name | Contact Assignment | Power Rail | I/O Buffer Type | Direction after Reset ¹ | Configuraton after Reset ¹ |
|--------------|--------------------|---------------|-----------------|------------------------------------|---------------------------------------|
| EIM_D29 | Y8 | NVCC_EMI | GPIO | Input | Keeper |
| EIM_D30 | AC9 | NVCC_EMI | GPIO | Input | Keeper |
| EIM_D31 | W7 | NVCC_EMI | GPIO | Input | Keeper |
| EIM_DA0 | AC15 | NVCC_EMI | GPIO | Input | Keeper |
| EIM_DA1 | V13 | NVCC_EMI | GPIO | Input | Keeper |
| EIM_DA10 | AC13 | NVCC_EMI | GPIO | Input | Keeper |
| EIM_DA11 | V11 | NVCC_EMI | GPIO | Input | Keeper |
| EIM_DA12 | AA12 | NVCC_EMI | GPIO | Input | Keeper |
| EIM_DA13 | W11 | NVCC_EMI | GPIO | Input | Keeper |
| EIM_DA14 | AB12 | NVCC_EMI | GPIO | Input | Keeper |
| EIM_DA15 | Y11 | NVCC_EMI | GPIO | Input | Keeper |
| EIM_DA2 | AA14 | NVCC_EMI | GPIO | Input | Keeper |
| EIM_DA3 | AB14 | NVCC_EMI | GPIO | Input | Keeper |
| EIM_DA4 | AC14 | NVCC_EMI | GPIO | Input | Keeper |
| EIM_DA5 | Y13 | NVCC_EMI | GPIO | Input | Keeper |
| EIM_DA6 | AA13 | NVCC_EMI | GPIO | Input | Keeper |
| EIM_DA7 | W13 | NVCC_EMI | GPIO | Input | Keeper |
| EIM_DA8 | AB13 | NVCC_EMI | GPIO | Input | Keeper |
| EIM_DA9 | Y12 | NVCC_EMI | GPIO | Input | Keeper |
| EIM_DTACK | Y5 | NVCC_EMI | GPIO | Input | 100 kΩ pull-up |
| EIM_EB0 | V12 | NVCC_EMI | GPIO | Output | High |
| EIM_EB1 | W12 | NVCC_EMI | GPIO | Output | High |
| EIM_EB2 | V10 | NVCC_EMI | GPIO | Input | Keeper |
| EIM_EB3 | V9 | NVCC_EMI | GPIO | Input | Keeper |
| EIM_LBA | AC2 | NVCC_EMI | GPIO | Output | High |
| EIM_OE | AA7 | NVCC_EMI | GPIO | Output | High |
| EIM_RW | AB3 | NVCC_EMI | GPIO | Output | High |
| EIM_SDBA0 | V1 | NVCC_EMI_DRAM | DDR2 | Output | High |
| EIM_SDBA1 | U3 | NVCC_EMI_DRAM | DDR2 | Output | High |
| EIM_SDBA2 | F1 | NVCC_EMI_DRAM | DDR2 | Output | High |
| EIM_SDODT0 | F3 | NVCC_EMI_DRAM | DDR2 | Output | High |
| EIM_SDODT1 | F2 | NVCC_EMI_DRAM | DDR2 | Output | High |

Table 131. 19 x 19 mm Signal Assignments, Power Rails, and I/O (continued)

| Contact Name | Contact Assignment | Power Rail | I/O Buffer Type | Direction after Reset ¹ | Configuraton after Reset ¹ |
|------------------------|--------------------|--------------|-----------------|------------------------------------|---------------------------------------|
| EIM_WAIT | AB4 | NVCC_EMI | GPIO | Input | 100 kΩ pull-up |
| EXTAL ² | AB20 | NVCC_OSC | Analog | Input | — |
| FASTR_ANA ² | W20 | NVCC_PER3 | — | Input | — |
| FASTR_DIG ² | Y20 | NVCC_PER3 | — | Input | — |
| GPANAIO ² | J23 | NVCC_USBPHY | Analog | Output | — |
| GPIO_NAND | D5 | NVCC_NANDF_A | UHvio | Input | 100 kΩ pull-up |
| GPIO1_0 | B21 | NVCC_PER5 | GPIO | Input | Keeper |
| GPIO1_1 | D20 | NVCC_PER5 | GPIO | Input | Keeper |
| GPIO1_2 | A22 | NVCC_PER5 | GPIO | Input | Keeper |
| GPIO1_3 | D18 | NVCC_PER5 | GPIO | Input | Keeper |
| GPIO1_4 | B22 | NVCC_PER5 | GPIO | Input | Keeper |
| GPIO1_5 | D19 | NVCC_PER5 | GPIO | Input | Keeper |
| GPIO1_6 | C19 | NVCC_PER5 | GPIO | Input | Keeper |
| GPIO1_7 | B23 | NVCC_PER5 | GPIO | Input | Keeper |
| GPIO1_8 | C21 | NVCC_PER5 | GPIO | Input | Keeper |
| GPIO1_9 | C20 | NVCC_PER5 | GPIO | Input | Keeper |
| I2C1_CLK | W15 | NVCC_I2C | I2CIO | Input | 47 kΩ pull-up |
| I2C1_DAT | AB16 | NVCC_I2C | I2CIO | Input | 47 kΩ pull-up |
| ID | L19 | NVCC_USBPHY | Analog | Input | Pull-up |
| IOB ² | AC19 | AHVDDRGB | Analog | Output | — |
| IOB_BACK ² | AB19 | — | Analog | Output | — |
| IOG ² | AC18 | AHVDDRGB | Analog | Output | — |
| IOG_BACK ² | AB18 | — | Analog | Output | — |
| IOR ² | AC17 | AHVDDRGB | Analog | Output | — |
| IOR_BACK ² | AB17 | — | Analog | Output | — |
| JTAG_DE_B | AB15 | NVCC_PER14 | GPIO | Input/Open-drain output | 47 kΩ pull-up |
| JTAG_MOD | V14 | NVCC_PER14 | GPIO | Input | 100 kΩ pull-up |
| JTAG_TCK | V15 | NVCC_PER14 | GPIO | Input | 100 kΩ pull-down |
| JTAG_TDI | Y14 | NVCC_PER14 | GPIO | Input | 47 kΩ pull-up |
| JTAG_TDO | AA15 | NVCC_PER14 | GPIO | 3-state output | Keeper |
| JTAG_TMS | AC16 | NVCC_PER14 | GPIO | Input | 47 kΩ pull-up |

Table 131. 19 x 19 mm Signal Assignments, Power Rails, and I/O (continued)

| Contact Name | Contact Assignment | Power Rail | I/O Buffer Type | Direction after Reset ¹ | Configuraton after Reset ¹ |
|-----------------------|--------------------|--------------|-----------------|------------------------------------|---------------------------------------|
| JTAG_TRSTB | W14 | NVCC_PER14 | GPIO | Input | 47 kΩ pull-up |
| KEY_COL0 | E15 | NVCC_PER13 | GPIO | Input | 100 kΩ pull-up |
| KEY_COL1 | A16 | NVCC_PER13 | GPIO | Input | 100 kΩ pull-up |
| KEY_COL2 | D15 | NVCC_PER13 | GPIO | Input | 100 kΩ pull-up |
| KEY_COL3 ⁴ | B17 | NVCC_PER13 | GPIO | Output | High |
| KEY_COL4 ⁴ | F16 | NVCC_PER13 | GPIO | Output | Low |
| KEY_COL5 ⁴ | C16 | NVCC_PER13 | GPIO | Output | Low |
| KEY_ROW0 | D14 | NVCC_PER13 | GPIO | Input | 100 kΩ pull-up |
| KEY_ROW1 | B16 | NVCC_PER13 | GPIO | Input | 100 kΩ pull-up |
| KEY_ROW2 | F15 | NVCC_PER13 | GPIO | Input | 100 kΩ pull-up |
| KEY_ROW3 | C15 | NVCC_PER13 | GPIO | Input | 100 kΩ pull-up |
| NANDF_ALE | E3 | NVCC_NANDF_A | UHVIO | Output | High |
| NANDF_CLE | F4 | NVCC_NANDF_A | UHVIO | Output | High |
| NANDF_CS0 | C3 | NVCC_NANDF_A | UHVIO | Output | High |
| NANDF_CS1 | C2 | NVCC_NANDF_A | UHVIO | Output | High |
| NANDF_CS2 | E4 | NVCC_NANDF_A | UHVIO | Output | High |
| NANDF_CS3 | B1 | NVCC_NANDF_A | UHVIO | Output | High |
| NANDF_CS4 | B2 | NVCC_NANDF_A | UHVIO | Output | Low |
| NANDF_CS5 | A2 | NVCC_NANDF_A | UHVIO | Output | Low |
| NANDF_CS6 | E5 | NVCC_NANDF_B | UHVIO | Output | Low |
| NANDF_CS7 | C4 | NVCC_NANDF_B | UHVIO | Output | Low |
| NANDF_D0 | A7 | NVCC_NANDF_C | UHVIO | Input | Keeper |
| NANDF_D1 | E8 | NVCC_NANDF_C | UHVIO | Input | Keeper |
| NANDF_D10 | B5 | NVCC_NANDF_B | UHVIO | Input | Keeper |
| NANDF_D11 | D7 | NVCC_NANDF_B | UHVIO | Input | Keeper |
| NANDF_D12 | C5 | NVCC_NANDF_B | UHVIO | Input | Keeper |
| NANDF_D13 | A3 | NVCC_NANDF_B | UHVIO | Input | Keeper |
| NANDF_D14 | B4 | NVCC_NANDF_B | UHVIO | Input | Keeper |
| NANDF_D15 | D6 | NVCC_NANDF_B | UHVIO | Input | Keeper |
| NANDF_D2 | A6 | NVCC_NANDF_C | UHVIO | Input | Keeper |
| NANDF_D3 | D8 | NVCC_NANDF_C | UHVIO | Input | Keeper |
| NANDF_D4 | B7 | NVCC_NANDF_C | UHVIO | Input | Keeper |

Table 131. 19 x 19 mm Signal Assignments, Power Rails, and I/O (continued)

| Contact Name | Contact Assignment | Power Rail | I/O Buffer Type | Direction after Reset ¹ | Configuraton after Reset ¹ |
|---------------|--------------------|---------------|-----------------|------------------------------------|---------------------------------------|
| NANDF_D5 | A5 | NVCC_NANDF_C | UHVIO | Input | Keeper |
| NANDF_D6 | B6 | NVCC_NANDF_C | UHVIO | Input | Keeper |
| NANDF_D7 | C6 | NVCC_NANDF_B | UHVIO | Input | Keeper |
| NANDF_D8 | A4 | NVCC_NANDF_B | UHVIO | Input | Keeper |
| NANDF_D9 | E7 | NVCC_NANDF_B | UHVIO | Input | Keeper |
| NANDF_RB0 | D2 | NVCC_NANDF_A | UHVIO | Input | 100 kΩ pull-up |
| NANDF_RB1 | D4 | NVCC_NANDF_A | UHVIO | Input | 100 kΩ pull-up |
| NANDF_RB2 | D3 | NVCC_NANDF_A | UHVIO | Input | 100 kΩ pull-up |
| NANDF_RB3 | C1 | NVCC_NANDF_A | UHVIO | Input | 100 kΩ pull-up |
| NANDF_RDY_INT | B3 | NVCC_NANDF_B | UHVIO | Input | 100 kΩ pull-up |
| NANDF_RE_B | E2 | NVCC_NANDF_A | UHVIO | Output | — |
| NANDF_WE_B | E1 | NVCC_NANDF_A | UHVIO | Output | — |
| NANDF_WP_B | D1 | NVCC_NANDF_A | UHVIO | Output | — |
| OWIRE_LINE | E14 | NVCC_PER12 | GPIO | Input | 100 kΩ pull-up |
| PMIC_INT_REQ | AA16 | NVCC_SRTC_POW | GPIO | Input | 100 kΩ pull-up |
| PMIC_ON_REQ | W16 | NVCC_SRTC_POW | GPIO | Input | 100 kΩ pull-up |
| PMIC_RDY | AA17 | NVCC_SRTC_POW | GPIO | Input | 100 kΩ pull-up |
| PMIC_STBY_REQ | Y15 | NVCC_SRTC_POW | GPIO | Input | 100 kΩ pull-up |
| POR_B | U20 | NVCC_PER3 | LVIO | Input | 100 kΩ pull-up |
| RESET_IN_B | Y21 | NVCC_PER3 | LVIO | Input | 100 kΩ pull-up |
| SD1_CLK | A17 | NVCC_PER15 | UHVIO | Output | — |
| SD1_CMD | E16 | NVCC_PER15 | UHVIO | Input | 47 kΩ pull-up |
| SD1_DATA0 | D16 | NVCC_PER15 | UHVIO | Input | 47 kΩ pull-up |
| SD1_DATA1 | A18 | NVCC_PER15 | UHVIO | Input | 47 kΩ pull-up |
| SD1_DATA2 | F17 | NVCC_PER15 | UHVIO | Input | 47 kΩ pull-up |
| SD1_DATA3 | A19 | NVCC_PER15 | UHVIO | Input | 360 kΩ pull-down |
| SD2_CLK | B18 | NVCC_PER17 | UHVIO | Output | — |
| SD2_CMD | G17 | NVCC_PER17 | UHVIO | Input | 47 kΩ pull-up |
| SD2_DATA0 | E17 | NVCC_PER17 | UHVIO | Input | 47 kΩ pull-up |
| SD2_DATA1 | B19 | NVCC_PER17 | UHVIO | Input | 47 kΩ pull-up |
| SD2_DATA2 | D17 | NVCC_PER17 | UHVIO | Input | 47 kΩ pull-up |
| SD2_DATA3 | C17 | NVCC_PER17 | UHVIO | Input | 360 kΩ pull-down |

Table 131. 19 x 19 mm Signal Assignments, Power Rails, and I/O (continued)

| Contact Name | Contact Assignment | Power Rail | I/O Buffer Type | Direction after Reset ¹ | Configuraton after Reset ¹ |
|-------------------|--------------------|------------|-----------------|------------------------------------|---------------------------------------|
| STR | A15 | NVCC_PER12 | — | — | — |
| TEST_MODE | V20 | NVCC_PER3 | GPIO | Input | 100 k Ω pull-down |
| UART1_CTS | B14 | NVCC_PER12 | GPIO | Input | 100 k Ω pull-up |
| UART1_RTS | D13 | NVCC_PER12 | GPIO | Input | 100 k Ω pull-up |
| UART1_RXD | E13 | NVCC_PER12 | GPIO | Input | 100 k Ω pull-up |
| UART1_TXD | A13 | NVCC_PER12 | GPIO | Input | 100 k Ω pull-up |
| UART2_RXD | A14 | NVCC_PER12 | GPIO | Input | 100 k Ω pull-up |
| UART2_TXD | C14 | NVCC_PER12 | GPIO | Input | 100 k Ω pull-up |
| UART3_RXD | F14 | NVCC_PER12 | GPIO | Input | Keeper |
| UART3_TXD | B15 | NVCC_PER12 | GPIO | Input | Keeper |
| USBH1_CLK | D11 | NVCC_PER11 | GPIO | Input | Keeper |
| USBH1_DATA0 | E12 | NVCC_PER11 | GPIO | Input | Keeper |
| USBH1_DATA1 | A11 | NVCC_PER11 | GPIO | Input | Keeper |
| USBH1_DATA2 | B12 | NVCC_PER11 | GPIO | Input | Keeper |
| USBH1_DATA3 | C12 | NVCC_PER11 | GPIO | Input | Keeper |
| USBH1_DATA4 | D12 | NVCC_PER11 | GPIO | Input | Keeper |
| USBH1_DATA5 | A12 | NVCC_PER11 | GPIO | Input | Keeper |
| USBH1_DATA6 | B13 | NVCC_PER11 | GPIO | Input | Keeper |
| USBH1_DATA7 | C13 | NVCC_PER11 | GPIO | Input | Keeper |
| USBH1_DIR | B11 | NVCC_PER11 | GPIO | Input | Keeper |
| USBH1_NXT | C11 | NVCC_PER11 | GPIO | Input | Keeper |
| USBH1_STP | E11 | NVCC_PER11 | GPIO | Input | Keeper |
| XTAL ² | AC20 | NVCC_OSC | Analog | Output | — |

¹ The state immediately after reset and before ROM firmware or software has executed.

² See [Table 3 on page 12](#) for more information.

³ During power-on reset this port acts as input for fuse override signal. See [Table 132 on page 189](#) for more information.

⁴ During power-on reset this port acts as output for diagnostic signal. See [Table 132 on page 189](#) for more information.

5.2.2.3 Fuse Override Considerations

Table 132 lists the contacts that can be overridden with fuse settings.

Table 132. Fuse Override Contacts

| Contact Name | Direction After Reset | Configuration After Reset | Signal Configuration ¹ | External Termination for Fuse Override |
|--------------|-----------------------|---------------------------|---|--|
| DISP1_DAT10 | Input | Keeper | BT_SPARE_SIZE | 4.7 k Ω pull-up or pull-down |
| DISP1_DAT11 | Input | Keeper | BT_LPB_FREQ[2] | 4.7 k Ω pull-up or pull-down |
| DISP1_DAT12 | Input | Keeper | BT_MLC_SEL | 4.7 k Ω pull-up or pull-down |
| DISP1_DAT13 | Input | Keeper | BT_MEM_CTL[0] | 4.7 k Ω pull-up or pull-down |
| DISP1_DAT14 | Input | Keeper | BT_MEM_CTL[1] | 4.7 k Ω pull-up or pull-down |
| DISP1_DAT15 | Input | Keeper | BT_BUS_WIDTH | 4.7 k Ω pull-up or pull-down |
| DISP1_DAT16 | Input | Keeper | BT_PAGE_SIZE[0] | 4.7 k Ω pull-up or pull-down |
| DISP1_DAT17 | Input | Keeper | BT_PAGE_SIZE[1] | 4.7 k Ω pull-up or pull-down |
| DISP1_DAT18 | Input | Keeper | BT_WEIM_MUXED[0] | 4.7 k Ω pull-up or pull-down |
| DISP1_DAT19 | Input | Keeper | BT_WEIM_MUXED[1] | 4.7 k Ω pull-up or pull-down |
| DISP1_DAT20 | Input | Keeper | BT_MEM_TYPE[0] | 4.7 k Ω pull-up or pull-down |
| DISP1_DAT21 | Input | Keeper | BT_MEM_TYPE[1] | 4.7 k Ω pull-up or pull-down |
| DISP1_DAT22 | Input | Keeper | BT_LPB_FREQ[0] | 4.7 k Ω pull-up or pull-down |
| DISP1_DAT23 | Input | Keeper | BT_LPB_FREQ[1] | 4.7 k Ω pull-up or pull-down |
| DISP1_DAT6 | Input | Keeper | BT_USB_SRC ² | 4.7 k Ω pull-up or pull-down |
| DISP1_DAT7 | Input | Keeper | BT_EEPROM_CFG | 4.7 k Ω pull-up or pull-down |
| DISP1_DAT8 | Input | Keeper | BT_SRC[0] | 4.7 k Ω pull-up or pull-down |
| DISP1_DAT9 | Input | Keeper | BT_SRC[1] | 4.7 k Ω pull-up or pull-down |
| EIM_A16 | Input | 100 k Ω pull-up | OSC_FREQ_SEL[0] | 4.7 k Ω pull-down or none for high level ³ |
| EIM_A17 | Input | 100 k Ω pull-up | OSC_FREQ_SEL[1] | 4.7 k Ω pull-down or none for high level ² |
| EIM_A18 | Input | 100 k Ω pull-up | BT_LPB[0] | 4.7 k Ω pull-down or none for high level ² |
| EIM_A19 | Input | 100 k Ω pull-up | BT_LPB[1] | 4.7 k Ω pull-down or none for high level ² |
| EIM_A20 | Input | 100 k Ω pull-up | BT_UART_SRC[0] | 4.7 k Ω pull-down or none for high level ² |
| EIM_A21 | Input | 100 k Ω pull-up | BT_UART_SRC[1] | 4.7 k Ω pull-down or none for high level ² |
| KEY_COL3 | Output | High | Output for diagnostic signal INT_BOOT during power-on reset | — |

Table 132. Fuse Override Contacts (continued)

| Contact Name | Direction After Reset | Configuration After Reset | Signal Configuration ¹ | External Termination for Fuse Override |
|--------------|-----------------------|---------------------------|---|--|
| KEY_COL4 | Output | Low | Output for diagnostic signal ANY_PU_RST during power-on reset | — |
| KEY_COL5 | Output | Low | Output for diagnostic signal JTAG_ACT during power-on reset | — |

¹ Signal Configuration as Fuse Override Input at Power Up. These are special I/O lines that control the boot up configuration during product development. In production, the boot configuration is controlled by fuses.

² External USB PHY selection is not functional.

³ Consider using an external 68 kΩ pull-up if system constraints indicate that the on-chip 100 kΩ pull-up is too weak.

5.2.3 19 x 19 Ball Map

See [Section 5.4, “19 x 19 mm, 0.8 Pitch Ball Map.”](#)

5.3 13 × 13 mm, 0.5 Pitch Ball Map

Table 133 shows the 13 x 13 mm, 0.5 pitch ball map.

Table 133. 13 × 13 mm, 0.5 mm Pitch Ball Map

| | G | F | E | D | C | B | A |
|----|-------------|-------------|-------------|---------------|-------------|-------------|-------------|
| 1 | DRAM_D29 | DRAM_D31 | NANDF_ALE | NANDF_CS1 | NANDF_RB1 | GND | GND |
| 2 | DRAM_D30 | DRAM_D16 | NANDF_CLE | NANDF_RB0 | NANDF_RB3 | NANDF_CS3 | NANDF_CS6 |
| 3 | DRAM_D18 | DRAM_D17 | NANDF_WP_B | NANDF_RB2 | GPIO_NAND | NANDF_CS4 | NANDF_D12 |
| 4 | DRAM_D21 | DRAM_D19 | NANDF_D14 | NANDF_CS0 | NANDF_CS5 | NANDF_D11 | NANDF_D8 |
| 5 | GND | — | — | NANDF_CS2 | NANDF_D10 | NANDF_D3 | NANDF_D7 |
| 6 | NANDF_WE_B | NANDF_RE_B | — | NANDF_RDY_INT | NANDF_D2 | NANDF_D4 | NANDF_D6 |
| 7 | — | NANDF_CS7 | GND | NANDF_D0 | CSI2_D19 | AUD3_BB_TXD | CSI2_D18 |
| 8 | — | NANDF_D5 | — | CSI2_D13 | AUD3_BB_FS | AUD3_BB_RXD | CSP11_RDY |
| 9 | — | NANDF_D1 | — | CSP11_MOSI | AUD3_BB_CK | USBH1_DATA4 | USBH1_DATA2 |
| 10 | — | NANDF_D13 | VDDGP | CSP11_SS0 | USBH1_DATA3 | USBH1_DIR | USBH1_DATA1 |
| 11 | — | CSI2_D12 | — | CSP11_SCLK | USBH1_CLK | USBH1_DATA0 | USBH1_STP |
| 12 | — | CSP11_MISO | — | USBH1_NXT | USBH1_DATA6 | USBH1_DATA7 | UART1_TXD |
| 13 | — | CSP11_SS1 | GND | UART1_RXD | UART1_RTS | UART1_CTS | UART2_RXD |
| 14 | — | USBH1_DATA5 | — | STR | UART2_TXD | UART3_RXD | UART3_TXD |
| 15 | — | KEY_ROW2 | — | KEY_ROW3 | KEY_ROW1 | KEY_ROW0 | OWIRE_LINE |
| 16 | — | SD2_CMD | GND | KEY_COL2 | KEY_COL1 | KEY_COL0 | KEY_COL3 |
| 17 | — | SD2_DATA3 | — | SD1_DATA1 | SD1_CMD | KEY_COL4 | KEY_COL5 |
| 18 | — | SD2_DATA0 | — | SD1_DATA2 | SD1_DATA3 | SD1_DATA0 | SD1_CLK |
| 19 | — | CSI1_MCLK | GND | CSI1_PIXCLK | CSI1_HSYNC | CSI1_VSYNC | SD2_CLK |
| 20 | D11_PIN15 | DI_GP1 | — | NVCC_PER5 | CSI2_VSYNC | CSI1_D9 | CSI1_D8 |
| 21 | — | — | — | CSI2_PIXCLK | GPIO1_1 | SD2_DATA1 | SD2_DATA2 |
| 22 | DISP1_DAT19 | DISP1_DAT15 | DISP1_DAT12 | DISP1_DAT14 | GPIO1_5 | GPIO1_4 | GPIO1_3 |
| 23 | DISP1_DAT18 | DISP1_DAT16 | DISP1_DAT13 | DISP1_DAT9 | DISP1_DAT8 | GPIO1_2 | GPIO1_7 |
| 24 | DISP1_DAT22 | DISP1_DAT17 | DISP1_DAT10 | DISP1_DAT7 | GPIO1_8 | GPIO1_6 | GND |
| 25 | DISP1_DAT20 | DISP1_DAT21 | DISP1_DAT11 | DISP1_DAT6 | GPIO1_9 | GND | GND |
| | G | F | E | D | C | B | A |

Table 133. 13 × 13 mm, 0.5 mm Pitch Ball Map (continued)

| | P | N | M | L | K | J | H |
|----|-------------|-------------|---------------|---------------|--------------|--------------|--------------|
| 1 | DRAM_A9 | DRAM_SDCKE0 | DRAM_SDCLK | DRAM_SDCKE1 | DRAM_SDQS3_B | DRAM_D25 | DRAM_D27 |
| 2 | DRAM_A12 | DRAM_DQM3 | DRAM_SDCLK_B | EIM_SDODT0 | DRAM_SDQS3 | DRAM_D26 | DRAM_D28 |
| 3 | DRAM_CS0 | DRAM_RAS | DRAM_SDWE | EIM_SDODT1 | DRAM_SDQS2 | DRAM_D22 | DRAM_D20 |
| 4 | EIM_SDBA0 | DRAM_CAS | DRAM_DQM2 | EIM_SDBA1 | DRAM_SDQS2_B | DRAM_D24 | DRAM_D23 |
| 5 | — | GND | NVCC_EMI_DRAM | NVCC_EMI_DRAM | GND | — | — |
| 6 | VDD_FUSE | GND | VDDGP | VDDGP | EIM_SDBA2 | NANDF_D15 | NANDF_D9 |
| 7 | — | — | — | — | — | — | — |
| 8 | GND | GND | VDDGP | VDDGP | VDDGP | NVCC_NANDF_A | NVCC_NANDF_B |
| 9 | GND | GND | VDDGP | VDDGP | VDDGP | VDDGP | NVCC_NANDF_C |
| 10 | SGND | GND | VDDGP | VDDGP | VDDGP | VDDGP | NVCC_PER9 |
| 11 | GND | GND | SVDDGP | VDDGP | VDDGP | VDDGP | NVCC_PER11 |
| 12 | VCC | VCC | GND | VDDGP | VDDGP | VDDGP | NVCC_PER10 |
| 13 | VCC | SVCC | GND | GND | GND | GND | VDDA |
| 14 | VCC | VCC | GND | GND | GND | GND | NVCC_PER13 |
| 15 | VCC | VCC | GND | GND | GND | NVCC_PER8 | NVCC_PER12 |
| 16 | NVCC_USBPHY | NVCC_IPU4 | NVCC_IPU6 | NVCC_IPU9 | NVCC_IPU5 | NVCC_PER17 | NVCC_PER15 |
| 17 | — | — | — | — | — | — | — |
| 18 | DISP2_DAT1 | VDDA | DISP2_DAT12 | DISP2_DAT8 | RREFEXT | DI1_PIN2 | GPIO1_0 |
| 19 | — | — | — | — | — | — | — |
| 20 | NVCC_HS4_2 | NVCC_HS6 | NVCC_HS10 | NVCC_HS4_1 | DI_GP2 | CSI2_HSYNC | DI1_PIN3 |
| 21 | GND | — | — | GND | — | — | — |
| 22 | CSI1_D12 | CSI1_D19 | CSI2_D17 | VBUS | GPANAIO | DI1_DISP_CLK | NVCC_IPU7 |
| 23 | CSI1_D13 | CSI1_D18 | CSI2_D16 | NGND_USBPHY | DI_GP4 | DI2_PIN4 | DI_GP3 |
| 24 | CSI1_D14 | CSI1_D16 | CSI2_D15 | VREG | DP | DI2_DISP_CLK | DI2_PIN2 |
| 25 | CSI1_D15 | CSI1_D17 | CSI2_D14 | ID | DN | DI2_PIN3 | DISP1_DAT23 |
| | P | N | M | L | K | J | H |

Table 133. 13 × 13 mm, 0.5 mm Pitch Ball Map (continued)

| | AA | Y | W | V | U | T | R |
|----|---------------|----------------|---------------|---------------|-------------|---------------|---------------|
| 1 | DRAM_D11 | DRAM_D8 | DRAM_SDQS1_B | DRAM_DQM0 | DRAM_A4 | DRAM_A6 | DRAM_A11 |
| 2 | DRAM_D10 | DRAM_D9 | DRAM_SDQS1 | DRAM_DQM1 | DRAM_A5 | DRAM_A7 | DRAM_A14 |
| 3 | DRAM_D4 | DRAM_D6 | DRAM_SDQS0 | DRAM_A1 | DRAM_A3 | DRAM_A8 | DRAM_CS1 |
| 4 | DRAM_D5 | DRAM_D7 | DRAM_SDQS0_B | DRAM_A0 | DRAM_A2 | DRAM_A10 | DRAM_A13 |
| 5 | NVCC_EMI_DRAM | NVCC_EMI_DRAM | GND | — | GND | NVCC_EMI_DRAM | NVCC_EMI_DRAM |
| 6 | — | EIM_A20 | EIM_CS1 | EIM_CRE | VREF | VDDA | VDDA |
| 7 | GND | EIM_CS5 | — | — | — | — | — |
| 8 | — | EIM_CS3 | — | NVCC_EMI | NVCC_EMI | GND | GND |
| 9 | — | EIM_A24 | — | NVCC_PER14 | GND | GND | GND |
| 10 | GND | EIM_BCLK | — | NVCC_PER3 | GND | GND | GND |
| 11 | — | EIM_D28 | — | NVCC_I2C | GND | GND | GND |
| 12 | — | EIM_A16 | — | NVCC_SRTC_POW | GND | GND | GND |
| 13 | GND | EIM_A18 | — | AHVSSRGB | GND | GND | VCC |
| 14 | — | EIM_OE | — | AHVSSRGB | VCC | VCC | VCC |
| 15 | — | EIM_RW | — | AHVDDRGB | VCC | VCC | VCC |
| 16 | GND | VDDA | — | AHVDDRGB | VCC | VCC | VDDA33 |
| 17 | — | EIM_CS0 | — | DISP2_DAT9 | — | — | — |
| 18 | — | EIM_DA5 | — | D11_PIN1 | DISP2_DAT13 | D11_D1_CS | DISP2_DAT10 |
| 19 | GND | I2C1_DAT | — | — | — | — | — |
| 20 | — | DISPB2_SER_DIO | D11_D0_CS | NVCC_IPU2 | DISP2_DAT14 | DISP2_DAT0 | DISP2_DAT6 |
| 21 | — | — | — | — | GND | — | — |
| 22 | CKIL | CLK_SS | BOOT_MODE0 | NVCC_IPU8 | DISP2_DAT2 | DISP1_DAT1 | DISP1_DAT5 |
| 23 | CKIH2 | DISPB2_SER_DIN | DISPB2_SER_RS | DISP2_DAT15 | DISP2_DAT3 | DISP1_DAT0 | DISP1_DAT4 |
| 24 | BOOT_MODE1 | POR_B | D11_PIN13 | DISP2_DAT11 | DISP2_DAT4 | DISP1_DAT2 | CS11_D10 |
| 25 | RESET_IN_B | DISPB2_SER_CLK | D11_PIN12 | DISP2_DAT7 | DISP2_DAT5 | DISP1_DAT3 | CS11_D11 |
| | AA | Y | W | V | U | T | R |

Table 133. 13 × 13 mm, 0.5 mm Pitch Ball Map (continued)

| | AE | AD | AC | AB |
|----|---------------|---------------|---------------|---------------|
| 1 | GND | GND | DRAM_D15 | DRAM_D13 |
| 2 | GND_DIG_PLL_A | GND | DRAM_D14 | DRAM_D12 |
| 3 | GND_ANA_PLL_A | VDD_DIG_PLL_A | DRAM_D1 | DRAM_D2 |
| 4 | EIM_CS2 | VDD_ANA_PLL_A | DRAM_D0 | DRAM_D3 |
| 5 | EIM_A23 | EIM_A25 | EIM_DTACK | EIM_LBA |
| 6 | EIM_A17 | EIM_A21 | EIM_A27 | EIM_WAIT |
| 7 | EIM_A19 | EIM_D29 | EIM_CS4 | EIM_A26 |
| 8 | EIM_D17 | EIM_D26 | EIM_D30 | EIM_D31 |
| 9 | EIM_D24 | EIM_D18 | EIM_D25 | EIM_A22 |
| 10 | EIM_D21 | EIM_D20 | EIM_D19 | EIM_D27 |
| 11 | EIM_D22 | EIM_DA15 | EIM_EB3 | EIM_D23 |
| 12 | EIM_DA11 | EIM_DA13 | EIM_DA14 | EIM_D16 |
| 13 | EIM_DA12 | EIM_DA9 | EIM_DA10 | EIM_EB2 |
| 14 | EIM_EB1 | EIM_EB0 | EIM_DA7 | EIM_DA8 |
| 15 | EIM_DA0 | EIM_DA1 | EIM_DA2 | EIM_DA6 |
| 16 | EIM_DA4 | JTAG_MOD | JTAG_DE_B | EIM_DA3 |
| 17 | JTAG_TRSTB | JTAG_TDO | JTAG_TMS | JTAG_TDI |
| 18 | PMIC_ON_REQ | JTAG_TCK | PMIC_INT_REQ | PMIC_STBY_REQ |
| 19 | IOR | IOR_BACK | PMIC_RDY | I2C1_CLK |
| 20 | IOG | IOG_BACK | COMP | VREFOUT |
| 21 | IOB | IOB_BACK | FASTR_DIG | TVDAC_DHVDD |
| 22 | FASTR_ANA | NVCC_OSC | NVCC_TV_BACK | NGND_TV_BACK |
| 23 | XTAL | EXTAL | NGND_OSC | VDD_DIG_PLL_B |
| 24 | GND | GND_DIG_PLL_B | VDD_ANA_PLL_B | CKIH1 |
| 25 | GND | GND | GND_ANA_PLL_B | TEST_MODE |
| | AE | AD | AC | AB |

5.4 19 x 19 mm, 0.8 Pitch Ball Map

Table 134 shows the 19 × 19 mm, 0.8 pitch ball map.

Table 134. 19 × 19 mm, 0.8 Pitch Ball Map

| | G | F | E | D | C | B | A |
|----|--------------|--------------|--------------|-------------|-------------|---------------|-------------|
| 1 | DRAM_D28 | EIM_SDBA2 | NANDF_WE_B | NANDF_WP_B | NANDF_RB3 | NANDF_CS3 | GND |
| 2 | DRAM_D29 | EIM_SDODT1 | NANDF_RE_B | NANDF_RB0 | NANDF_CS1 | NANDF_CS4 | NANDF_CS5 |
| 3 | DRAM_D30 | EIM_SDODT0 | NANDF_ALE | NANDF_RB2 | NANDF_CS0 | NANDF_RDY_INT | NANDF_D13 |
| 4 | DRAM_D31 | NANDF_CLE | NANDF_CS2 | NANDF_RB1 | NANDF_CS7 | NANDF_D14 | NANDF_D8 |
| 5 | GND | NVCC_NANDF_A | NANDF_CS6 | GPIO_NAND | NANDF_D12 | NANDF_D10 | NANDF_D5 |
| 6 | VDDGP | VDDGP | NVCC_NANDF_A | NANDF_D15 | NANDF_D7 | NANDF_D6 | NANDF_D2 |
| 7 | VDDGP | VDDGP | NANDF_D9 | NANDF_D11 | CSI2_D13 | NANDF_D4 | NANDF_D0 |
| 8 | VDDA | VDDGP | NANDF_D1 | NANDF_D3 | AUD3_BB_CK | CSI2_D12 | CSI2_D19 |
| 9 | NVCC_NANDF_B | VDDGP | AUD3_BB_TXD | CSI2_D18 | CSP11_RDY | AUD3_BB_RXD | AUD3_BB_FS |
| 10 | NVCC_NANDF_C | VDDGP | CSP11_SS0 | CSP11_MOSI | CSP11_MISO | CSP11_SS1 | CSP11_SCLK |
| 11 | NVCC_PER11 | VDDGP | USBH1_STP | USBH1_CLK | USBH1_NXT | USBH1_DIR | USBH1_DATA1 |
| 12 | NVCC_PER12 | VDDGP | USBH1_DATA0 | USBH1_DATA4 | USBH1_DATA3 | USBH1_DATA2 | USBH1_DATA5 |
| 13 | NVCC_PER13 | SVDDGP | UART1_RXD | UART1_RTS | USBH1_DATA7 | USBH1_DATA6 | UART1_TXD |
| 14 | NVCC_PER17 | UART3_RXD | OWIRE_LINE | KEY_ROW0 | UART2_TXD | UART1_CTS | UART2_RXD |
| 15 | NVCC_PER5 | KEY_ROW2 | KEY_COL0 | KEY_COL2 | KEY_ROW3 | UART3_TXD | STR |
| 16 | NVCC_IPU4 | KEY_COL4 | SD1_CMD | SD1_DATA0 | KEY_COL5 | KEY_ROW1 | KEY_COL1 |
| 17 | SD2_CMD | SD1_DATA2 | SD2_DATA0 | SD2_DATA2 | SD2_DATA3 | KEY_COL3 | SD1_CLK |
| 18 | CSI1_VSYNC | CSI1_PIXCLK | CSI1_D8 | GPIO1_3 | CSI2_HSYNC | SD2_CLK | SD1_DATA1 |
| 19 | DISP1_DAT15 | CSI2_VSYNC | CSI2_PIXCLK | GPIO1_5 | GPIO1_6 | SD2_DATA1 | SD1_DATA3 |
| 20 | DISP1_DAT18 | DISP1_DAT13 | DISP1_DAT9 | GPIO1_1 | GPIO1_9 | CSI1_MCLK | CSI1_HSYNC |
| 21 | DISP1_DAT23 | DISP1_DAT17 | DISP1_DAT12 | DISP1_DAT8 | GPIO1_8 | GPIO1_0 | CSI1_D9 |
| 22 | D11_PIN3 | DISP1_DAT22 | DISP1_DAT14 | DISP1_DAT10 | DISP1_DAT6 | GPIO1_4 | GPIO1_2 |
| 23 | D11_PIN2 | DISP1_DAT20 | DISP1_DAT16 | DISP1_DAT11 | DISP1_DAT7 | GPIO1_7 | GND |
| | G | F | E | D | C | B | A |

Table 134. 19 × 19 mm, 0.8 Pitch Ball Map (continued)

| | P | N | M | L | K | J | H |
|----|---------------|---------------|---------------|---------------|---------------|---------------|---------------|
| 1 | DRAM_SDQS0_B | DRAM_D9 | DRAM_D12 | DRAM_D18 | DRAM_D19 | DRAM_SDQS2 | DRAM_D25 |
| 2 | DRAM_SDQS0 | DRAM_D8 | DRAM_DQM1 | DRAM_D17 | DRAM_DQM2 | DRAM_SDQS2_B | DRAM_D26 |
| 3 | DRAM_DQM0 | DRAM_SDQS1_B | DRAM_D10 | DRAM_D16 | DRAM_D20 | DRAM_D22 | DRAM_SDQS3 |
| 4 | DRAM_D6 | DRAM_SDQS1 | DRAM_D11 | DRAM_D15 | DRAM_D21 | DRAM_D23 | DRAM_SDQS3_B |
| 5 | DRAM_D5 | DRAM_D7 | DRAM_D13 | DRAM_D14 | DRAM_D24 | DRAM_D27 | DRAM_DQM3 |
| 6 | NVCC_EMI_DRAM | NVCC_EMI_DRAM | NVCC_EMI_DRAM | NVCC_EMI_DRAM | NVCC_EMI_DRAM | NVCC_EMI_DRAM | NVCC_EMI_DRAM |
| 7 | VCC | VCC | VCC | VCC | VDDGP | VDDGP | VDDGP |
| 8 | GND | GND | VDDA | GND | GND | GND | VDDA |
| 9 | GND | GND | GND | GND | GND | GND | GND |
| 10 | GND | GND | GND | GND | GND | GND | NVCC_PER9 |
| 11 | GND | GND | GND | GND | GND | SGND | NVCC_PER10 |
| 12 | GND | GND | GND | GND | GND | GND | VDDA |
| 13 | GND | GND | GND | GND | GND | GND | VCC |
| 14 | GND | GND | GND | GND | GND | GND | SVCC |
| 15 | GND | GND | GND | VCC | VCC | VCC | NVCC_PER15 |
| 16 | VDDA | GND | NVCC_HS10 | NGND_USBPHY | VCC | VCC | NVCC_PER8 |
| 17 | VCC | VCC | NVCC_HS6 | NVCC_USBPHY | NVCC_IPU7 | NVCC_IPU6 | NVCC_IPU5 |
| 18 | NVCC_IPU8 | NVCC_HS4_2 | NVCC_HS4_1 | VDDA33 | DI2_PIN3 | DI1_DISP_CLK | DISP1_DAT19 |
| 19 | DISP2_DAT8 | DISP2_DAT6 | DISP2_DAT1 | ID | RREFEXT | DI_GP2 | DISP1_DAT21 |
| 20 | DISP2_DAT2 | DISP1_DAT0 | CSI1_D14 | CSI2_D14 | VBUS | DI2_PIN2 | DI1_PIN15 |
| 21 | DISP2_DAT3 | DISP1_DAT1 | CSI1_D15 | CSI2_D15 | VREG | DI2_DISP_CLK | DI_GP1 |
| 22 | CSI1_D12 | CSI1_D16 | CSI1_D18 | CSI2_D16 | DN | DI_GP4 | DI_GP3 |
| 23 | CSI1_D13 | CSI1_D17 | CSI1_D19 | CSI2_D17 | DP | GPANAIO | DI2_PIN4 |
| | P | N | M | L | K | J | H |

Table 134. 19 × 19 mm, 0.8 Pitch Ball Map (continued)

| | AA | Y | W | V | U | T | R |
|----|--------------|---------------|---------------|----------------|----------------|---------------|---------------|
| 1 | DRAM_SDCKE0 | DRAM_A7 | DRAM_RAS | EIM_SDBA0 | DRAM_A13 | DRAM_D0 | DRAM_D3 |
| 2 | DRAM_A1 | DRAM_A5 | DRAM_A8 | DRAM_A10 | DRAM_A12 | DRAM_A14 | DRAM_D2 |
| 3 | DRAM_A2 | DRAM_CS1 | DRAM_A6 | DRAM_A9 | EIM_SDBA1 | DRAM_SDCLK | DRAM_D1 |
| 4 | EIM_BCLK | DRAM_CS0 | DRAM_A4 | DRAM_CAS | DRAM_A11 | DRAM_SDCLK_B | DRAM_D4 |
| 5 | EIM_CS5 | EIM_DTACK | DRAM_SDCKE1 | DRAM_A3 | DRAM_SDWE | GND | VREF |
| 6 | EIM_CS4 | EIM_CS1 | EIM_CS0 | VDD_ANA_PLL_A | VDD_DIG_PLL_A | NVCC_EMI_DRAM | NVCC_EMI_DRAM |
| 7 | EIM_OE | EIM_CS2 | EIM_D31 | NVCC_EMI | GND_ANA_PLL_A | GND_DIG_PLL_A | VDD_FUSE |
| 8 | EIM_A19 | EIM_D29 | EIM_D27 | EIM_D23 | NVCC_EMI | VCC | GND |
| 9 | EIM_A16 | EIM_D25 | EIM_D21 | EIM_EB3 | NVCC_EMI | VCC | GND |
| 10 | EIM_D24 | EIM_D19 | EIM_D17 | EIM_EB2 | NVCC_EMI | VCC | GND |
| 11 | EIM_D18 | EIM_DA15 | EIM_DA13 | EIM_DA11 | NVCC_EMI | VCC | GND |
| 12 | EIM_DA12 | EIM_DA9 | EIM_EB1 | EIM_EB0 | NVCC_EMI | VCC | GND |
| 13 | EIM_DA6 | EIM_DA5 | EIM_DA7 | EIM_DA1 | NVCC_PER14 | VDDA | GND |
| 14 | EIM_DA2 | JTAG_TDI | JTAG_TRSTB | JTAG_MOD | NVCC_SRTC_POW | NVCC_I2C | GND |
| 15 | JTAG_TDO | PMIC_STBY_REQ | I2C1_CLK | JTAG_TCK | VREFOUT | NGND_TV_BACK | GND |
| 16 | PMIC_INT_REQ | CKIL | PMIC_ON_REQ | TVDAC_DHVDD | NVCC_TV_BACK | GND | GND |
| 17 | PMIC_RDY | COMP | NVCC_OSC | NGND_OSC | GND_ANA_PLL_B | VCC | VCC |
| 18 | AHVDDRGB | AHVDDRGB | VDD_DIG_PLL_B | GND_DIG_PLL_B | NVCC_PER3 | NVCC_IPU2 | NVCC_IPU9 |
| 19 | AHVSSRGB | AHVSSRGB | VDD_ANA_PLL_B | CKIH1 | DISPB2_SER_DIN | DISP2_DAT13 | DISP2_DAT11 |
| 20 | CKIH2 | FASTR_DIG | FASTR_ANA | TEST_MODE | POR_B | DI1_PIN13 | DISP2_DAT9 |
| 21 | CLK_SS | RESET_IN_B | DISPB2_SER_RS | DISPB2_SER_DIO | DI1_D0_CS | DISP2_DAT15 | DISP2_DAT0 |
| 22 | DI1_PIN12 | DI1_PIN11 | DISP2_DAT10 | DISP2_DAT4 | DISP1_DAT2 | DISP1_DAT4 | CSI1_D10 |
| 23 | DISP2_DAT14 | DISP2_DAT12 | DISP2_DAT7 | DISP2_DAT5 | DISP1_DAT3 | DISP1_DAT5 | CSI1_D11 |
| | AA | Y | W | V | U | T | R |

Table 134. 19 × 19 mm, 0.8 Pitch Ball Map (continued)

| | AC | AB |
|----|----------------|------------|
| 1 | GND | DRAM_A0 |
| 2 | EIM_LBA | EIM_CRE |
| 3 | EIM_CS3 | EIM_RW |
| 4 | EIM_A26 | EIM_WAIT |
| 5 | EIM_A24 | EIM_A27 |
| 6 | EIM_A23 | EIM_A25 |
| 7 | EIM_A21 | EIM_A22 |
| 8 | EIM_A18 | EIM_A20 |
| 9 | EIM_D30 | EIM_A17 |
| 10 | EIM_D28 | EIM_D26 |
| 11 | EIM_D22 | EIM_D20 |
| 12 | EIM_D16 | EIM_DA14 |
| 13 | EIM_DA10 | EIM_DA8 |
| 14 | EIM_DA4 | EIM_DA3 |
| 15 | EIM_DA0 | JTAG_DE_B |
| 16 | JTAG_TMS | I2C1_DAT |
| 17 | IOR | IOR_BACK |
| 18 | IOG | IOG_BACK |
| 19 | IOB | IOB_BACK |
| 20 | XTAL | EXTAL |
| 21 | GND | BOOT_MODE0 |
| 22 | DISPB2_SER_CLK | BOOT_MODE1 |
| 23 | GND | D11_D1_CS |
| | AC | AB |

6 Revision History

Table 135 provides a revision history for this data sheet.

Table 135. i.MX51 Data Sheet Document Revision History

| Rev. Number | Date | Substantive Change(s) |
|-------------|---------|--|
| Rev. 6 | 10/2012 | <ul style="list-style-type: none"> In Table 25, "I/O Leakage Current," on page 31, updated supply rail names for SD1 and SD2 to NVCC_PER15 and NVCC_PER17, respectively. Updated Section 4.6.7.3, "General WEIM Timing-Synchronous Mode." Updated Section 4.6.7.4, "Examples of WEIM Synchronous Accesses." Updated Section 4.6.7.5, "General WEIM Timing-Asynchronous Mode." |
| Rev. 5 | 03/2012 | <ul style="list-style-type: none"> In Table 4, "JTAG Controller Interface Summary," on page 14, changed On-Chip Termination column value for JTAG_MOD from "100 kΩ pull-down" to "100 kΩ pull-up." In Section 3.7, "USB-OTG IOMUX Pin Configuration," removed the third sentence from the first paragraph and added a note after Table 9. In Section 4.3.4, "Ultra-High Voltage I/O (UHVIO) DC Parameters," added clarification about UHVIO I/O cell HVE bit functionality after Table 21. In Section 4.6.9, "DDR2 SDRAM Specific Parameters:" <ul style="list-style-type: none"> —Updated Table 58, "DDR2 SDRAM Timing Parameter Table," on page 69 —Added a note after Table 58 —Updated Figure 36, "DDR2 SDRAM Write Cycle Timing Diagram," on page 71 —Updated Table 60, "DDR2 SDRAM Write Cycle Parameter Table," on page 71 —Added a note after Table 60 —Updated Figure 37, "DDR2 SDRAM DQ versus DQS and SDCLK Read Cycle Timing Diagram," on page 73 —Updated Table 63, "DDR2 SDRAM Read Cycle Parameter Table," on page 73 —Added a note after Table 63 In Section 4.7.8.2, "Electrical Characteristics," changed signal name in the second sentence of the first paragraph from "SENSB_MCLK" to "SENSB_PIX_CLK." In Table 128, "13 x 13 mm Signal Assignments, Power Rails, and I/O," on page 157, changed Configurator after Reset column value for contacts, DI1_D0_CS, DI1_D1_CS, DI1_PIN11, and DI1_PIN12, from "Low" to "High." In Table 128, "13 x 13 mm Signal Assignments, Power Rails, and I/O," on page 157, changed Configurator after Reset column value for contact, JTAG_MOD, from "100 kΩ pull-down" to "100 kΩ pull-up." In Table 128, "13 x 13 mm Signal Assignments, Power Rails, and I/O," on page 157, changed Power Rail column value for contacts, UART1_CTS, UART1_RTS, UART1_RXD, UART1_TXD, UART2_RXD, UART2_TXD, UART3_RXD, and UART3_TXD, from "NVVCC_PER12" to "NVCC_PER12." In Table 131, "19 x 19 mm Signal Assignments, Power Rails, and I/O," on page 177, changed Configurator after Reset column value for contacts, DI1_D0_CS, DI1_D1_CS, DI1_PIN11, and DI1_PIN12, from "Low" to "High." In Table 131, "19 x 19 mm Signal Assignments, Power Rails, and I/O," on page 177, changed Configurator after Reset column value for contact, JTAG_MOD, from "100 kΩ pull-down" to "100 kΩ pull-up." In Table 131, "19 x 19 mm Signal Assignments, Power Rails, and I/O," on page 177, changed Power Rail column value for contacts, UART1_CTS, UART1_RTS, UART1_RXD, UART1_TXD, UART2_RXD, UART2_TXD, UART3_RXD, and UART3_TXD, from "NVVCC_PER12" to "NVCC_PER12." In Table 132, "Fuse Override Contacts," on page 189: <ul style="list-style-type: none"> —Added a footnote for contact, DISP1_DAT6 —Removed information about contact, EIM_A23, because the signal configuration it corresponds to, BT_HP_N_EN, is not in use. Corrected cross-references throughout the document. |

Revision History

Table 135. i.MX51 Data Sheet Document Revision History (continued)

| Rev. Number | Date | Substantive Change(s) |
|-------------|---------|--|
| Rev. 4 | 08/2010 | <ul style="list-style-type: none"> • Updated Case Temperature Range column of Table 1, "Ordering Information," on page 3. • Updated Table 13, "i.MX51 Operating Ranges," on page 19 to include separate specification for case temperature for industrial parts. • Removed table footnote in Table 16, "i.MX51 Stop Mode Current and Power Consumption," on page 21. • Removed table footnote in Table 47, "CAMP Electrical Parameters (CKIH1, CKIH2)," on page 48. • Updated Table 52, "WEIM Interface Pinout in Various Configurations," on page 55. |
| Rev. 3 | 06/2010 | <ul style="list-style-type: none"> • Updated Max column of Table 15, "Fuse Supply Current," on page 21. Deleted eFuse Read Current row from the same table. • Updated Symbol, Test Conditions, and Max columns of Table 18, "GPIO/HSGPIO DC Electrical Characteristics," on page 25. • Updated Max and Unit columns of Table 19, "DDR2 I/O DC Electrical Parameters," on page 26. • Updated Test Conditions, Max, and Unit columns of Table 20, "LVIO DC Electrical Characteristics," on page 26 • Updated Symbol, Test Conditions, Max, and Unit columns of Table 21, "UHvio DC Electrical Characteristics," on page 27. • Updated Max and Unit columns of Table 22, "I2C Standard/Fast/High-Speed Mode Electrical Parameters for Low/Medium Drive Strength," on page 29. • Added a new table Table 25, "I/O Leakage Current," on page 31. |

Table 135. i.MX51 Data Sheet Document Revision History (continued)

| Rev. Number | Date | Substantive Change(s) |
|-------------|---------|--|
| Rev. 2 | 05/2010 | <ul style="list-style-type: none"> • Updated Case Temperature Range column in Table 1, "Ordering Information," on page 3. • Changed the VREFOUT column in Table 3, "Special Signal Considerations," on page 12. • Added Section 3, "IOMUX Configuration for Boot Media". • Updated Figure 2, "Power-Up Sequence," on page 24. • Updated the Minimum and Maximum columns in Table 13, "i.MX51 Operating Ranges," on page 19. • Added a note in Section 4.2.1, "Power-Up Sequence". • Updated Section 4.2.1, "Power-Up Sequence." • Changed the Input current (47 kΩ Pull-up) column in Table 21, "UHVIO DC Electrical Characteristics," on page 27 to Input current (75 kΩ Pull-up). • Added new table for parameters for DDR2 Pad output buffer Impedance. See Table 27, "DDR2 I/O Output Buffer Impedance HVE = 0," on page 32. • Added new section under Section 4.5, "I/O AC Parameters". See Section 4.5.4, "AC Electrical Characteristics for DDR2". • Updated Table 47, "CAMP Electrical Parameters (CKIH1, CKIH2)," on page 48. In the VIH (for square wave input) parameter, the minimum frequency was changed to NVCC_PER3 - 0.25V and the maximum frequency was changed to NVCC_PER3. • Added a note in Section 4.6.6, "NAND Flash Controller (NFC) Parameters" after Table 49. • Updated Asymmetric Mode Min, Symmetric Mode Min, and Max columns of Table 50. • Removed Conditions parameters of the Full scale output voltage row in Table 82. • Updated Section 4.7.11, "P-ATA Timing Parameters". Replaced ATA/ATAPI-6 specification with ATA/ATAPI-5 specification. • In Table 102, "SSI Transmitter Timing with Internal Clock," on page 135, under the Synchronous Internal Clock Operation sections for the ID SS42, minimum frequency was changed from 10.0 to 30. • In Table 103, "SSI Receiver Timing with Internal Clock," on page 136, under the Internal Clock Operation section for ID SS20, minimum frequency was changed from 10.0 to 30. • In Table 104, "SSI Transmitter Timing with External Clock," on page 138, under the External Clock Operation section for ID SS38, maximum frequency was changed from 15.0 to 30. • Added a new section Section 4.7.16.1, "UART Electrical", under Section 4.7.16, "UART". • In Table 118, "USB Port Timing Specification in VP_VM Bi-directional Mode," on page 148, for IDs SS28 and SS29, direction was changed from out to in. • In Table 120, "USB Timing Specification in VP_VM Unidirectional Mode," on page 150, for IDs US40 and US41, direction was changed from out to in and the reference signal was changed to USB_VM1 and USB_VP1 respectively. • In Table 122, "USB Timing Specification for ULPI Parallel Mode," on page 151, added an extra row for ID17. • Updated Signal and Direction columns in Table 120, "USB Timing Specification in VP_VM Unidirectional Mode," on page 150. • Updated Signal names in Table 118, "USB Port Timing Specification in VP_VM Bi-directional Mode," on page 148. |
| Rev. 1 | 10/2009 | Initial public release. |

How to Reach Us:

Home Page:

freescale.com

Web Support:

freescale.com/support

Information in this document is provided solely to enable system and software implementers to use Freescale products. There are no express or implied copyright licenses granted hereunder to design or fabricate any integrated circuits based on the information in this document.

Freescale reserves the right to make changes without further notice to any products herein. Freescale makes no warranty, representation, or guarantee regarding the suitability of its products for any particular purpose, nor does Freescale assume any liability arising out of the application or use of any product or circuit, and specifically disclaims any and all liability, including without limitation consequential or incidental damages. "Typical" parameters that may be provided in Freescale data sheets and/or specifications can and do vary in different applications, and actual performance may vary over time. All operating parameters, including "typicals," must be validated for each customer application by customer's technical experts. Freescale does not convey any license under its patent rights nor the rights of others. Freescale sells products pursuant to standard terms and conditions of sale, which can be found at the following address: freescale.com/SalesTermsandConditions.

Freescale and the Freescale logo are trademarks of Freescale Semiconductor, Inc. Reg. U.S. Pat. & Tm. Off. All other product or service names are the property of their respective owners. ARM is the registered trademark of ARM Limited. ARM Cortex™-A8 is the trademark of ARM Limited.

© 2012 Freescale Semiconductor, Inc. All rights reserved.

Document Number: IMX51CEC

Rev. 6

09/2012

