



Part Number: DVI1722

Electrical Specifications

Frequency Range (GHz):	17.3 - 22.0
Isolation (dB):	20 MIN
Insertion Loss (dB):	0.5 MAX
VSWR:	1.25:1 MIN
Forward Power (W):	10 AVG 30 PK
Reflective Power (W):	2 AVG

Mechanical/Environmental Specifications

Connector Type:	SMA
Connector Body:	Passivated stainless steel
Connector Pin:	Gold plated copper
Load Body:	Brass
Magnetic Shunt:	Nickel plated CRS
Operational Temp:	-20°C to +65°C
Weight (oz)	0.9 MAX
Outgassing	Low outgassing materials only

To customize test procedures or specifications to your requirements, please contact DiTom.

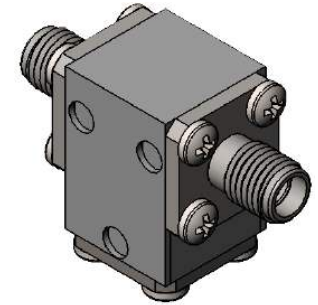

DVI1722 Dimensions

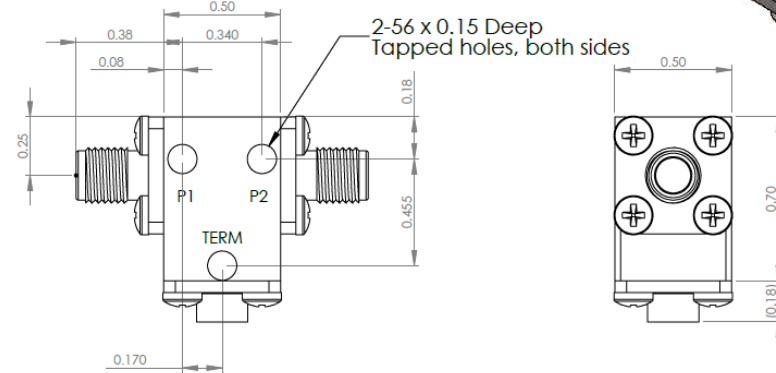

DVI1722-3 Dimensions

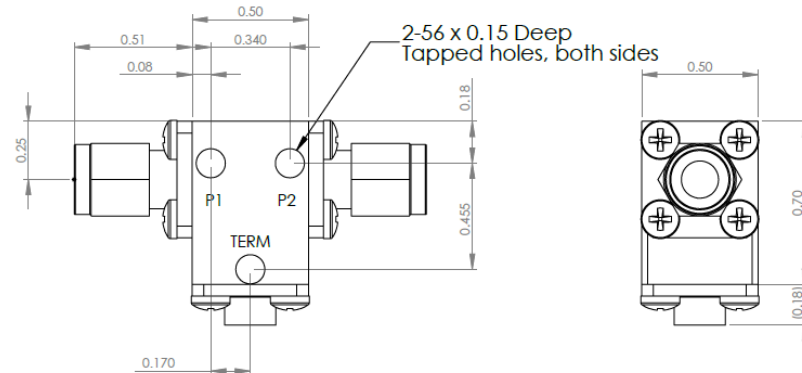

Dimensions are in inches
Tolerance

XX	±0.03
XXX	±0.010

Type of Device	PN Suffix	Connector Configuration Input / Output	PN Example
Single and Dual Junction Isolator, 2-Port Device	N/A	Female / Female	DVI1722
	-1	Male / Female	DVI1722-1
	-2	Female / Male	DVI1722-2
	-3	Male / Male	DVI1722-3



MEASURED DATA

Part Number: DV11722, +25°C

