

OPTION C

- NOTES:
 1. MATERIAL:
 HOUSING: POLYESTER(PBT), GLASS FILLED, UL94 V-0,
 COLOR: BLACK
 TERMINAL: PHOSPHOR BRONZE
 2. FINISH:
 TIN: 3.81 MICROMETERS/150 MICRINCHES MINIMUM TIN
 OVER NICKEL UNDERPLATE OVERALL
 3. TO BE USED WITH 26 AWG STRANDED WIRE WITH (1.35)/.053
 DIAMETER MAXIMUM INSULATION
 4. SEE TABLE FOR AVAILABLE CIRCUIT SIZES
 5. STANDARD PACKAGING PER PK-70873-0001. OPTIONAL PACKAGING
 MAY BE AVAILABLE, REQUEST DRAWING PK-70400
 6. PARTS STACKABLE END TO END ON (2.54)/.100 CENTERS
 7. PRODUCT SPECIFICATION: PS-70400
 8. SEE DRAWING SDA-70400-**** (SHEET 3) FOR OPTIONAL
 HOUSING DETAILS
 9. 4 CIRCUIT SHOWN. 3-25 CIRCUITS HAVE 2 RIBS
 10. TO MATE WITH MOLEX PART NUMBERS: A-70374-****,
 A-70376-****, A-70390-****, A-70392-****,
 A-70544-****, A-70554-****, A-70542-****,
 A-70552-****, A-70546-****, A-70556-****,
 11. 2 CIRCUIT ASSEMBLIES SUPPLIED AS GROUPED PAIRS

CKT. SIZE	A	B	EDP. NO.
2	(2.54) .100	(5.05) .199	14-60-0029
3	(5.08) .200	(7.59) .299	14-60-0039
4	(7.62) .300	(10.13) .399	14-60-0049
5	(10.16) .400	(12.67) .499	14-60-0059
6	(12.70) .500	(15.21) .599	14-60-0069
7	(15.24) .600	(17.75) .699	14-60-0079
8	(17.78) .700	(20.29) .799	14-60-0089
9	(20.32) .800	(22.83) .899	14-60-0099
10	(22.86) .900	(25.37) .999	14-60-0109
11	(25.54) 1.000	(27.91) 1.099	14-60-0119
12	(27.94) 1.100	(30.45) 1.199	14-60-0129
13	(30.48) 1.200	(32.99) 1.299	14-60-0139
14	(33.02) 1.300	(35.53) 1.399	14-60-0149
15	(35.56) 1.400	(38.07) 1.499	14-60-0159
16	(38.01) 1.500	(40.61) 1.599	14-60-0169
17	(40.64) 1.600	(43.15) 1.699	14-60-0179
18	(43.18) 1.700	(45.69) 1.799	14-60-0189
19	(45.72) 1.800	(48.23) 1.899	14-60-0199
20	(48.26) 1.900	(50.77) 1.999	14-60-0209
21	(50.80) 2.000	(53.31) 2.099	14-60-0219
22	(53.34) 2.100	(55.85) 2.199	14-60-0229
23	(55.88) 2.200	(58.39) 2.299	14-60-0239
24	(58.42) 2.300	(60.93) 2.399	14-60-0249
25	(60.96) 2.400	(63.47) 2.499	14-60-0259

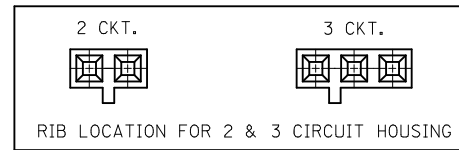
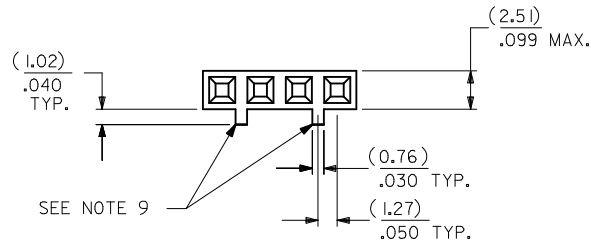

SECTION C-C

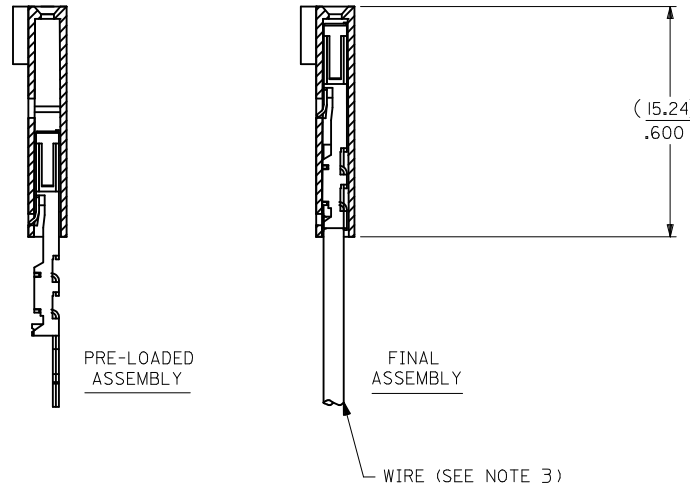

CIRCUIT NO. 1
 SLOT OR ARROW

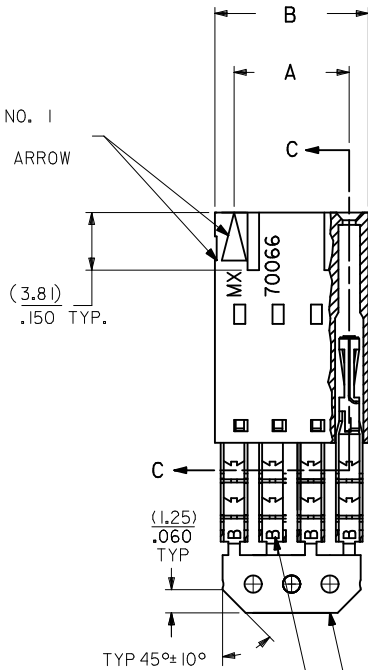

I.D. SLOT CODE TO WIRE GAUGE CHART	
I.D. SLOT CODE	WIRE GAUGE
B	26 AWG.

PLATING CODE (STRIPE ON CARRIER STRIP)	
PLATING	COLOR
TIN	NONE

REMOVE ENG NO. EC NO: UCP2011-110 DRW:MSI BARRA 2010/10/19 CHKD:J MORGAN 2010/10/19 APPR:SMILLER 2010/11/24	QUALITY SYMBOLS ▽=0 ▽=0 ▽=0	GENERAL TOLERANCES (UNLESS SPECIFIED)	DIMENSION STYLE MM/IN	SCALE	DESIGN UNITS INCH	THIRD ANGLE PROJECTION
		4 PLACES ± --- ± --- 3 PLACES ± --- ± .010 2 PLACES ± 0.25 ± .014 1 PLACE ± 0.35 ± --- ANGULAR ± 1/2°	DRAWN BY MSI BARRA DATE 2010/10/19 CHECKED BY WAZ DATE 1984/10/09 APPROVED BY SMILLER DATE 2010/11/24	TITLE ASSEMBLY, SL CONNECTOR SINGLE ROW 2.54/.100 GRID	MOLEX INCORPORATED	
DRAFT WHERE APPLICABLE MUST REMAIN WITHIN DIMENSIONS		SEE TABLE	DOCUMENT NO. SDA-70400-0211-0234			
THIS DRAWING CONTAINS INFORMATION THAT IS PROPRIETARY TO MOLEX INCORPORATED AND SHOULD NOT BE USED WITHOUT WRITTEN PERMISSION						

OPTION C

- NOTES:
 1. MATERIAL:
 HOUSING: POLYESTER(PBT), GLASS FILLED, UL94 V-0,
 COLOR: BLACK
 TERMINAL: PHOSPHOR BRONZE
 2. FINISH:
 TIN: 3.81 MICROMETERS/150 MICRINCHES MINIMUM TIN
 OVER NICKEL UNDERPLATE OVERALL
 3. TO BE USED WITH 26 AWG STRANDED WIRE WITH (1.35)/.053
 DIAMETER MAXIMUM INSULATION
 4. SEE TABLE FOR AVAILABLE CIRCUIT SIZES
 5. STANDARD PACKAGING PER PK-70873-0001. OPTIONAL PACKAGING
 MAY BE AVAILABLE, REQUEST DRAWING PK-70400
 6. PARTS STACKABLE END TO END ON (2.54)/.100 CENTERS
 7. PRODUCT SPECIFICATION: PS-70400
 8. SEE DRAWING SDA-70400-**** (SHEET 3) FOR OPTIONAL
 HOUSING DETAILS
 9. 4 CIRCUIT SHOWN. 3-25 CIRCUITS HAVE 2 RIBS
 10. TO MATE WITH MOLEX PART NUMBERS: A-70374-****,
 A-70376-****, A-70390-****, A-70392-****,
 A-70544-****, A-70554-****, A-70542-****,
 A-70552-****, A-70546-****, A-70556-****,
 11. 2 CIRCUIT ASSEMBLIES SUPPLIED AS GROUPED PAIRS

CKT. SIZE	A	B	EDP. NO.
2	(2.54) .100	(5.05) .199	14-60-0029
3	(5.08) .200	(7.59) .299	14-60-0039
4	(7.62) .300	(10.13) .399	14-60-0049
5	(10.16) .400	(12.67) .499	14-60-0059
6	(12.70) .500	(15.21) .599	14-60-0069
7	(15.24) .600	(17.75) .699	14-60-0079
8	(17.78) .700	(20.29) .799	14-60-0089
9	(20.32) .800	(22.83) .899	14-60-0099
10	(22.86) .900	(25.37) .999	14-60-0109
11	(25.54) 1.000	(27.91) 1.099	14-60-0119
12	(27.94) 1.100	(30.45) 1.199	14-60-0129
13	(30.48) 1.200	(32.99) 1.299	14-60-0139
14	(33.02) 1.300	(35.53) 1.399	14-60-0149
15	(35.56) 1.400	(38.07) 1.499	14-60-0159
16	(38.01) 1.500	(40.61) 1.599	14-60-0169
17	(40.64) 1.600	(43.15) 1.699	14-60-0179
18	(43.18) 1.700	(45.69) 1.799	14-60-0189
19	(45.72) 1.800	(48.23) 1.899	14-60-0199
20	(48.26) 1.900	(50.77) 1.999	14-60-0209
21	(50.80) 2.000	(53.31) 2.099	14-60-0219
22	(53.34) 2.100	(55.85) 2.199	14-60-0229
23	(55.88) 2.200	(58.39) 2.299	14-60-0239
24	(58.42) 2.300	(60.93) 2.399	14-60-0249
25	(60.96) 2.400	(63.47) 2.499	14-60-0259

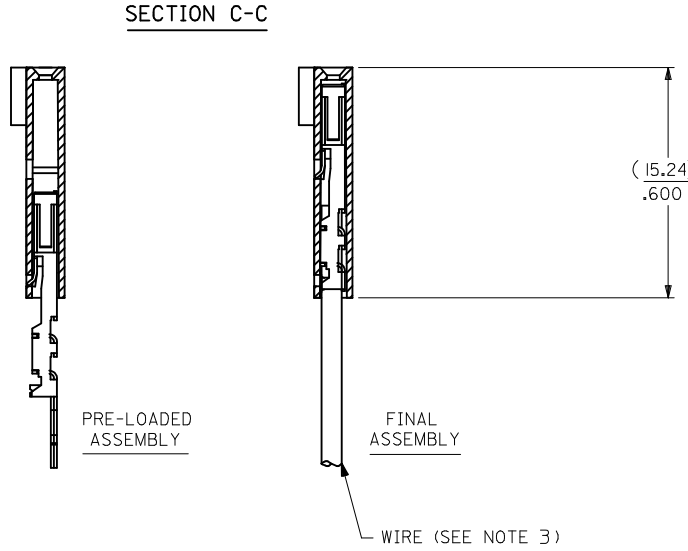
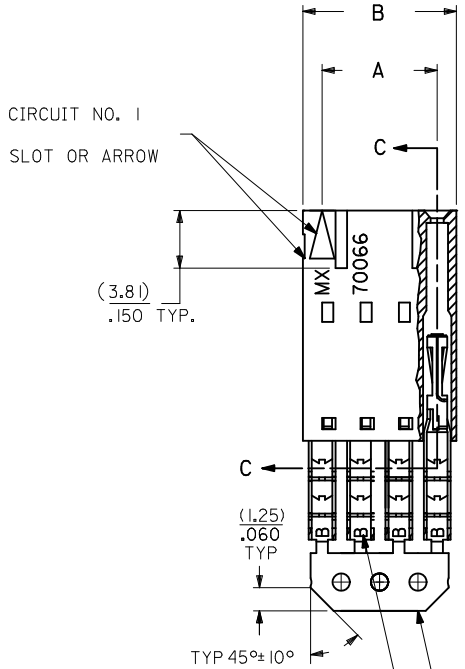
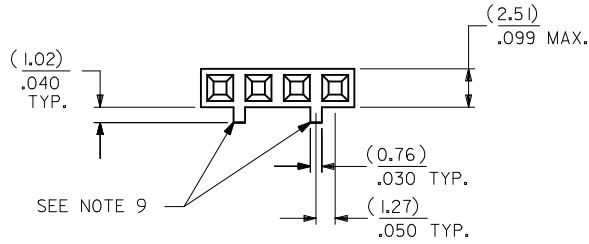

I.D. SLOT CODE TO WIRE GAUGE CHART	
I.D. SLOT CODE	WIRE GAUGE
B	26 AWG.

PLATING CODE (STRIPE ON CARRIER STRIP)	
PLATING	COLOR
TIN	NONE

REMOVE ENG NO. EC NO: UCP2011-110 DRW:MSI BARRA 2010/10/19 CHK:DJMORGAN 2010/10/19 APPR:SMILLER 2010/11/24	QUALITY SYMBOLS ▽=0 ▽=0 ▽=0	GENERAL TOLERANCES (UNLESS SPECIFIED) mm INCH 4 PLACES ± --- ± --- 3 PLACES ± --- ± .010 2 PLACES ± 0.25 ± .014 1 PLACE ± 0.35 ± --- ANGULAR ±1/2°	DIMENSION STYLE MM/IN DRAWN BY DATE MSI BARRA 2010/10/19 CHECKED BY DATE WAZ 1984/10/09 APPROVED BY DATE SMILLER 2010/11/24	SCALE DESIGN UNITS INCH TITLE ASSEMBLY, SL CONNECTOR SINGLE ROW 2.54/.100 GRID	THIRD ANGLE PROJECTION
		DRAFT WHERE APPLICABLE MUST REMAIN WITHIN DIMENSIONS	MATERIAL NO. SEE TABLE	DOCUMENT NO. SDA-70400-0211-0234	SHEET NO. 1 OF 1
		THIS DRAWING CONTAINS INFORMATION THAT IS PROPRIETARY TO MOLEX INCORPORATED AND SHOULD NOT BE USED WITHOUT WRITTEN PERMISSION			
		MOLEX MOLEX INCORPORATED			