

LOC		DIST		REVISIONS			
P	LTR	DESCRIPTION	DATE	DN	APVD	CT	KT
F		REV PER ECO 09-025422	11-16-09				

1. CONNECTOR DIMENSIONS ARE PER ARINC 600 SPECIFICATION UNLESS OTHERWISE SPECIFIED.
2. CONNECTOR IS SUPPLIED WITH CONTACTS (PER TABLE) ASSEMBLED AS SHOWN.
3. KEYING SHOWN IN POSITION FOR ILLUSTRATION ONLY. CONNECTORS SHIPPED WITH KEYING INSTALLED IN POSITION PER TABLE.
4. DUST COVER INSTALLED FOR SHIPPING, NOT SHOWN.
5. WITH CONTACT FULLY SEATED IN CAVITY.
6. THIS DIMENSION IS MEASURED TO THE BACK OF THE SHELL NOT THE HIRF.

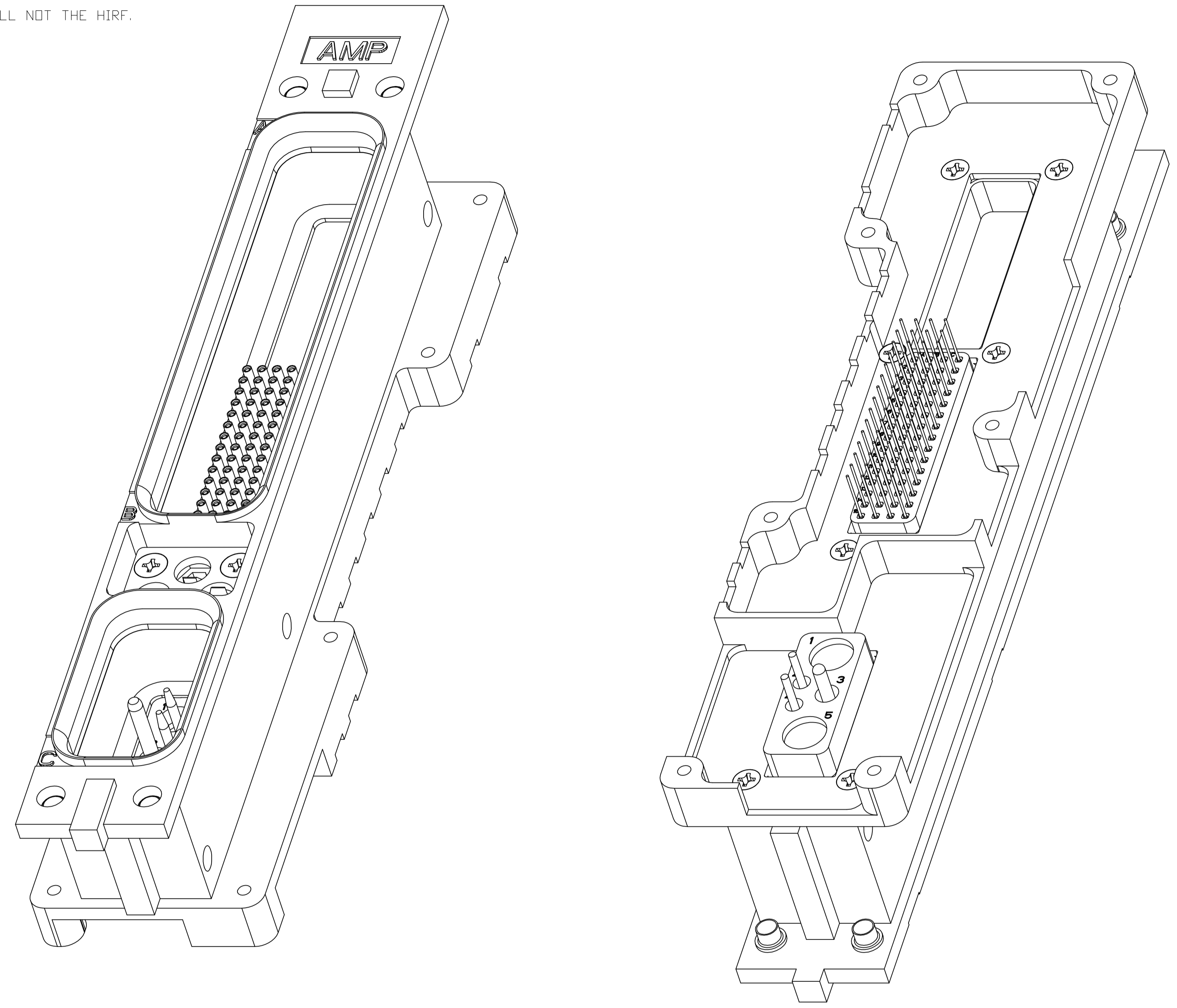

COMPONENT	MATERIAL	FINISH
SHELL	DIE CAST ALUMINUM PER ASTM-B-85	ELECTROLESS NICKEL PER MIL-C-26074
HIRF HOUSING RETENTION PLATE	ALUMINUM ALLOY 6061-T6	ELECTROLESS NI QQ-N-290 .0005 MIN OVER CU .0002
SCREWS AND LOCK WASHERS	STEEL	ZINC PLATED OVER SUPPLEMENTAL CHROMATE
POLARIZING KEYS	ZINC ALLOY PER ASTM-B-86	-
POLARIZING KEY RETAINING PLATE	ALUMINUM ALLOY PER ASTM-B-209	BLUE ANODIZED PER MIL-A-8625
60 & 5C2 INSERTS	THERMOSET	-
BLANK INSERT	ALUMINUM ALLOY PER ASTM-B-209	ELECTROLESS NICKEL PER MIL-C-26074
FILLER PLUG	TEFLON	-

"02"	HIRF P/N: 1996860-1; HONEYWELL P/N: 047-50541-0501 MODULE A: BLANK MODULE B: SZ 22 POSTED PIN CONTACT: TE P/N 1-211431-8 (QTY=60) MODULE C: SZ 16 POSTED PIN CONTACT: TE P/N 3-448139-3 (QTY=2) LOADED IN POSITION #2 & 4 SZ 12 POSTED PIN CONTACT: TE P/N 2-448140-2 (QTY=1) LOADED IN POSITION #3	1996503-1
KEYING POSITION	CONTACTS INCLUDED AND INSTALLED	PART NUMBER

THIS DRAWING IS A CONTROLLED DOCUMENT.

DIMENSIONS: INCHES [mm]	TOLERANCES UNLESS OTHERWISE SPECIFIED:	DIN C.C.THOMAS 10-9-08	APVD K.THACKSTON 10-9-08	NAME K.THACKSTON 10-9-08	SIZE A1	CAGE CODE 00779	DRAWING NO. 1996503	RESTRICTED TO
0 PLC ± -	1 PLC ± -	2 PLC ± -	3 PLC ± .005 [0.13]	4 PLC ± -	WEIGHT -	SCALE 3:2	SHEET 1 OF 2	REV F
MATERIAL SEE TABLE	FINISH SEE TABLE	Tyco Electronics Corporation Harrisburg, PA 17105-3608		RECEPTACLE ASSY, SIZE 1, ARINC 600 (BLANK/60/5C2)		CUSTOMER DRAWING		

LOC		DIST		REVISIONS			
P	LTR	DESCRIPTION	DATE	DNW	APVD		
-	-	SEE SHEET #1	-	-	-	-	-

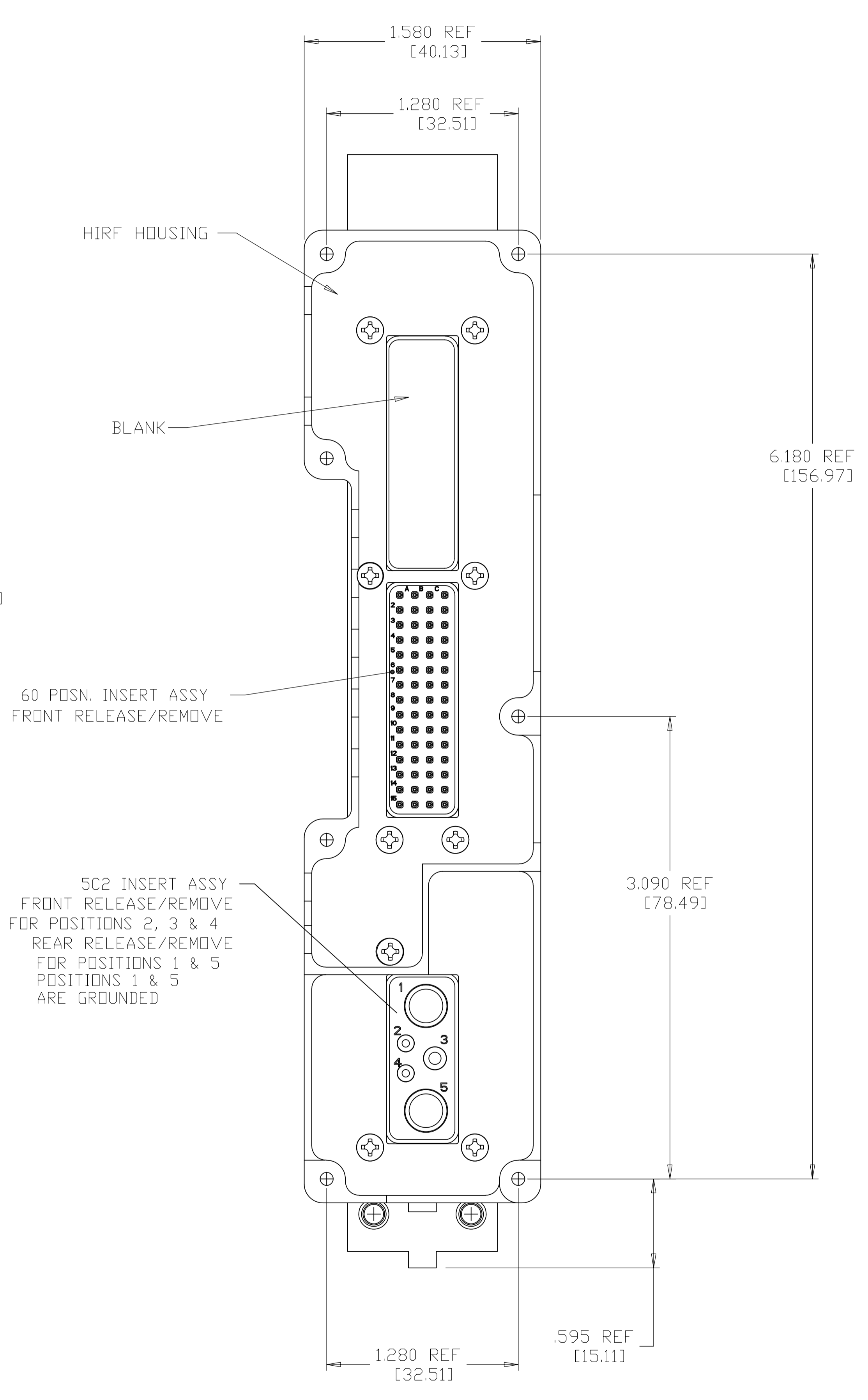
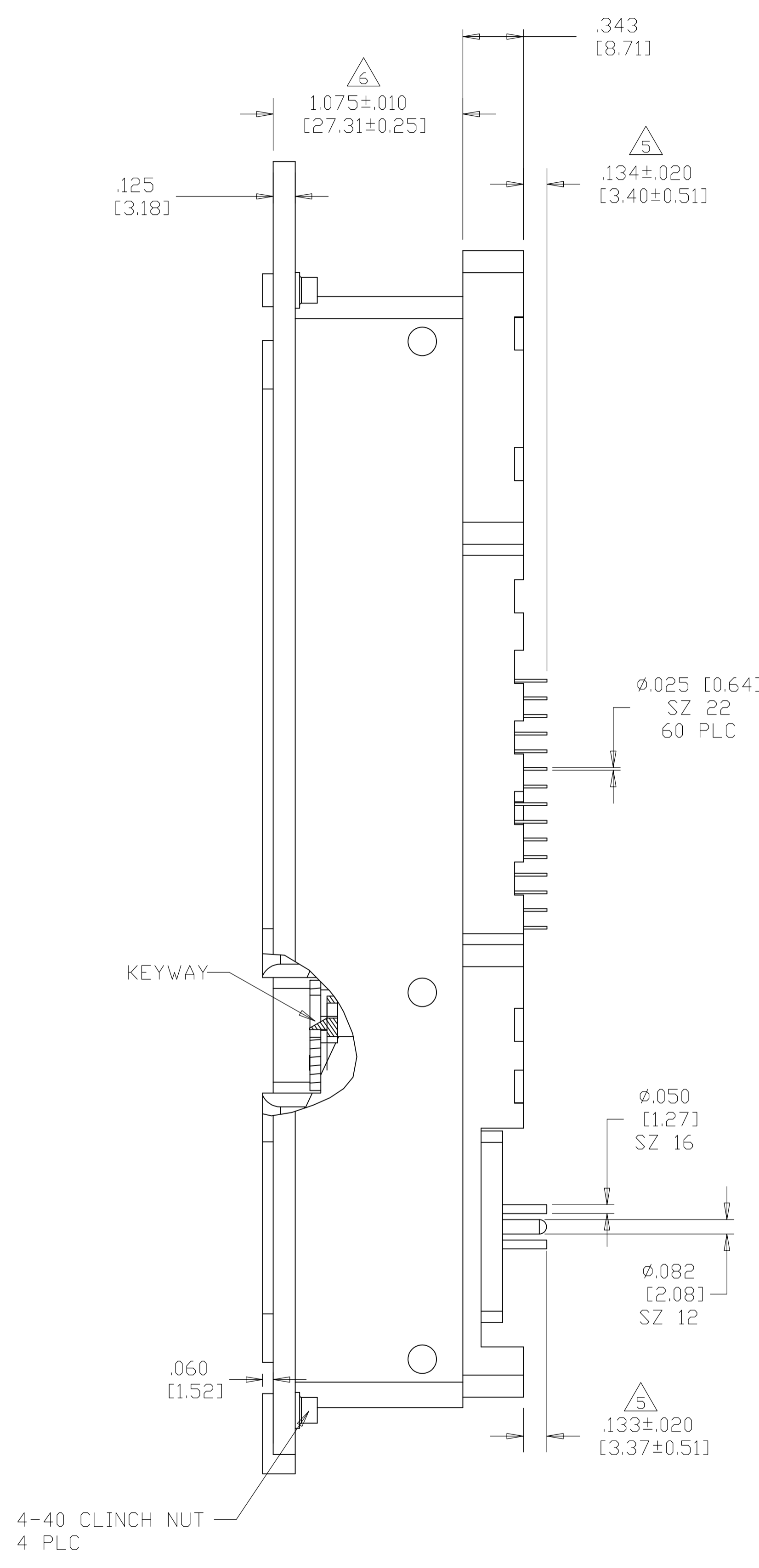
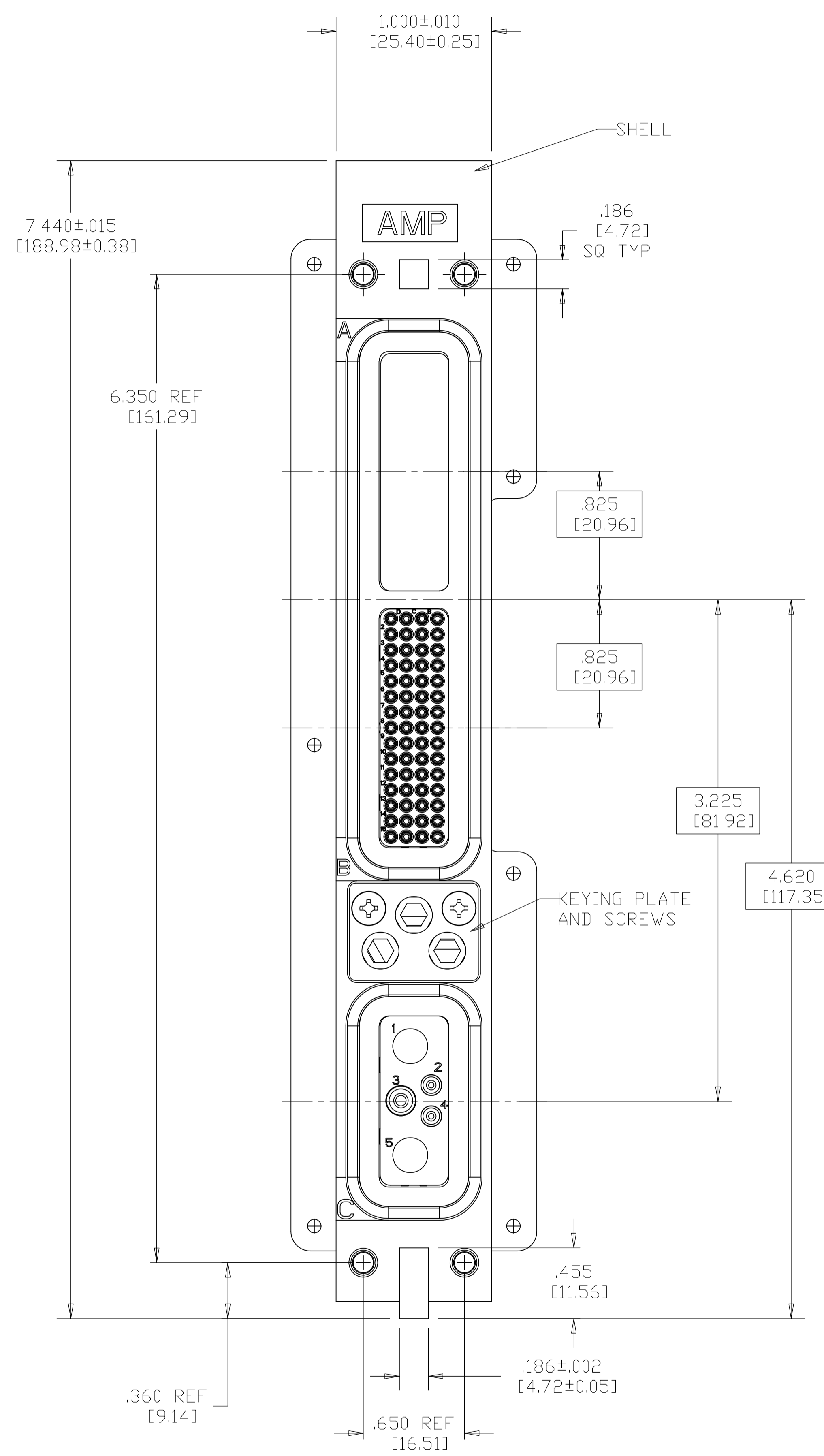

THIS DRAWING IS A CONTROLLED DOCUMENT.		DIN C.C.THOMAS 10-9-08	Tyco Electronics Corporation Harrisburg, PA 17105-3608	
DIMENSIONS: INCHES [mm]		CHK K.THACKSTON 10-9-08	NAME K.THACKSTON 10-9-08	
TOLERANCES UNLESS OTHERWISE SPECIFIED:		PRODUCT SPEC		
0 PLC ± -		APPLICATION SPEC		
1 PLC ± -		SIZE A1		
2 PLC ± -		CAGE CODE 00779		
3 PLC ± .005 [0.13]		DRAWING NO 1996503		
4 PLC ± -		RESTRICTED TO		
ANGLES ± -		WEIGHT		
FINISH SEE TABLE		CUSTOMER DRAWING		
		SCALE 3:2 SHEET 2 OF 2 REV F		