

SCREW ASSEMBLY DETAIL FOR -47-50 OPTION SCALE 2:1

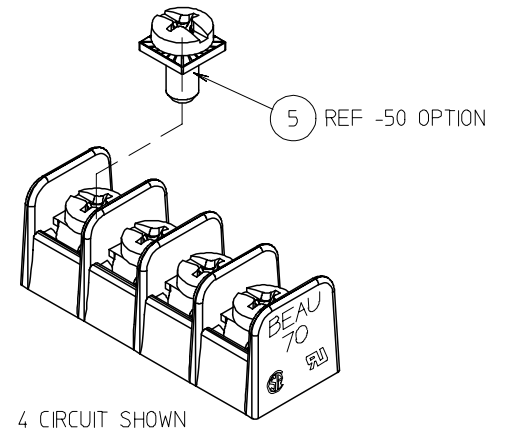

4 CIRCUIT SHOWN

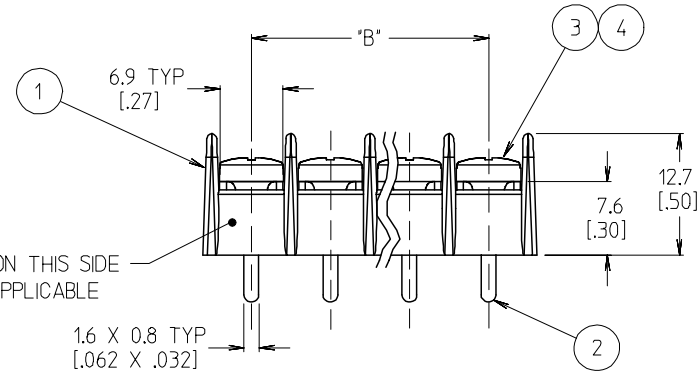

IMPRINT ON THIS SIDE WHERE APPLICABLE

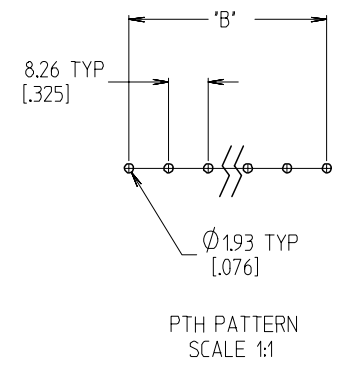
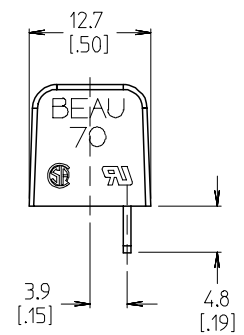

PTH PATTERN SCALE 1:1

NOTES:

1. MATERIAL: SEE TABLE
2. FINISHES: SEE TABLE
3. PRODUCT SPECIFICATION: NOT REQUIRED
4. INCH DIMENSIONS ARE SHOWN IN BRACKETS [.XXX].
5. "XX" REFERS TO THE QUANTITY OF CIRCUIT POSITIONS
6. ALL COMPONENTS ARE ROHS COMPLIANT.
7. FOR IMPRINTING SEE SD-38120-001.

ITEM	QTY	DESCRIPTION	MATERIAL	FINISH
6	*XX*	SCREW, #6-32, PAN HD, PH-SL, W/SO WSHR (-47-50 OPTION)	STEEL	ZN, CLEAR CHROMATE
5	*XX*	SCREW, #6-32, PAN HD, PH-SL, W/SO WSHR (-50 OPTION)	STEEL	ZN, CLEAR CHROMATE
4	*XX*	SCREW, #6-32, PAN HD, PH-SL, BRASS (-49 OPTION)	BRASS	NICKEL
3	*XX*	SCREW, #6-32, PAN HD, PH-SL (STANDARD)	STEEL	ZN, CLEAR CHROMATE
2	*XX*	TERMINAL, PC LONG SN/B	BRASS	TIN
1	1	BARRIER	THERMOPLASTIC	BLACK

INITIAL RELEASE
 EC NO: ETC2007-0010
 DRW: NEHLE 2006/08/07
 CHKD: JMACNEIL 2006/08/08
 APPR: RDEROSS 2006/08/09

QUALITY SYMBOLS
 ▽=0
 ▽=0

GENERAL TOLERANCES (UNLESS SPECIFIED)	
mm	INCH
4 PLACES ± ---	± ---
3 PLACES ± ---	± .005
2 PLACES ± 0.13	± .01
1 PLACE ± 0.3	± ---
ANGULAR ± 2 °	

DIMENSION STYLE	
MM/IN	DATE
DRAWN BY	EHILE 2006/07/26
CHECKED BY	RDEROSS 2006/07/26
APPROVED BY	RDEROSS 2006/07/26

SCALE	DESIGN UNITS	THIRD ANGLE PROJECTION
2:1	INCH	☑
TITLE SR BTS ASSY, PC LONG, NO MTG		
MATERIAL NO. SEE CHART		
DOCUMENT NO. SD-38709-013		SHEET NO. 1 OF 2

THIS DRAWING CONTAINS INFORMATION THAT IS PROPRIETARY TO MOLEX INCORPORATED AND SHOULD NOT BE USED WITHOUT WRITTEN PERMISSION

NO. OF CIRCUITS "XX"	DIM. "A"		DIM. "B"		ASSEMBLY MATERIAL NO. (-C-19 OPTION)	ASSEMBLY MATERIAL NO. (-C-19-49 OPTION)	ASSEMBLY MATERIAL NO. (-C-19-50 OPTION)	ASSEMBLY MATERIAL NO. (-C-19-47-50 OPTION)	ASSEMBLY MATERIAL NO. (-C-19-10A OPTION)
	mm	INCH	mm	INCH					
02	18.4	0.73	8.26	0.325	-	-	-	-	-
03	26.7	1.05	16.51	0.650	-	-	387090046	-	-
04	34.9	1.38	24.77	0.975	-	-	387090083	387090098	-
05	43.2	1.70	33.02	1.300	-	-	-	387090120	-
06	51.4	2.03	41.28	1.625	387090298	-	-	387090148	-
07	59.7	2.35	49.53	1.950	-	-	-	-	-
08	67.9	2.68	57.79	2.275	387090360	-	387090183	-	387090493
09	76.2	3.00	66.04	2.600	-	-	-	-	-
10	84.5	3.33	74.30	2.925	387090452	-	-	-	-
11	92.7	3.65	82.55	3.250	-	-	-	-	-
12	101.0	3.98	90.81	3.575	387090243	387090241	-	-	-
13	109.2	4.30	99.06	3.900	-	-	387090250	-	-
14	117.5	4.63	107.32	4.225	387090258	-	387090255	-	-
15	125.7	4.95	115.57	4.550	-	-	387090260	-	-
16	134.0	5.28	123.83	4.875	-	-	387090263	-	-
17	142.2	5.60	132.08	5.200	-	-	-	-	-
18	150.5	5.93	140.34	5.525	-	-	-	-	-
19	158.8	6.25	148.59	5.850	-	-	-	-	-
20	167.0	6.58	156.85	6.175	-	-	-	-	-
21	175.3	6.90	165.10	6.500	-	-	-	-	-
22	183.5	7.23	173.36	6.825	-	-	-	387090283	-
23	191.8	7.55	181.61	7.150	-	-	-	-	-
24	200.0	7.88	189.87	7.475	-	-	387090286	-	-
25	208.3	8.20	198.12	7.800	-	-	-	-	-
26	216.5	8.53	206.38	8.125	-	-	-	-	-
27	224.8	8.85	214.63	8.450	-	-	-	-	-
28	233.0	9.18	222.89	8.775	-	-	-	-	-
29	241.3	9.50	231.14	9.100	-	-	-	-	-
30	249.6	9.83	239.40	9.425	-	-	-	-	-

INITIAL RELEASE EC NO: ETC2007-0010 DRW:EHILE 2006/08/07 CHKD:JMACNEIL 2006/08/08 APPR:RDEROSS 2006/08/09 A	QUALITY SYMBOLS ▽=0 ▽=0	GENERAL TOLERANCES (UNLESS SPECIFIED)		DIMENSION STYLE MM/IN		SCALE 2:1	DESIGN UNITS INCH	THIRD ANGLE PROJECTION	
		4 PLACES ± --- ± ---	3 PLACES ± --- ± .005	DRAWN BY EHILE	DATE 2006/07/26	TITLE SR BTS ASSY, PC LONG, NO MTG			
		2 PLACES ± 0.13 ± .01	1 PLACE ± 0.3 ± ---	CHECKED BY RDEROSS	DATE 2006/07/26				
		ANGULAR ± 2 °		APPROVED BY RDEROSS	DATE 2006/07/26	MOLEX INCORPORATED			
DRAFT WHERE APPLICABLE MUST REMAIN WITHIN DIMENSIONS		MATERIAL NO. SEE CHART		DOCUMENT NO. SD-38709-013		SHEET NO. 2 OF 2			