

Ratings

Voltage: 150 V
 Temperature: -40~70 °C

Conductor

Conductor count: 8
 Gauge: 24 AWG 0.21 mm²
 Material: Tinned copper strands
 Strand size: $\phi 0.08 \times 41$
 Resistance at 20 °C: 95 Ω /km Max

Insulator

Material: HDPE
 Color: black, white, red, yellow, blue, green, orange, purple
 Diameter: $\phi 1.05 \pm 0.10$ mm
 Nominal thickness: 0.22 mm
 Resistance at 20 °C: 100 M Ω /km Min

Wrap

Material: cotton paper

Filler

Material: aramid fiber

Outer jacket

Material: TPU
 Color: gray
 Diameter: $\phi 4.9 \pm 0.25$ mm
 Nominal thickness: 0.60 mm

Tests

Tensile strength: 26 kgf min
 Dielectric test: 1500 V dc for 1 minute without breakdown
 Bend test at 200 g, $\pm 60^\circ$, 30 cycles /min: 15,000 cycle minimum

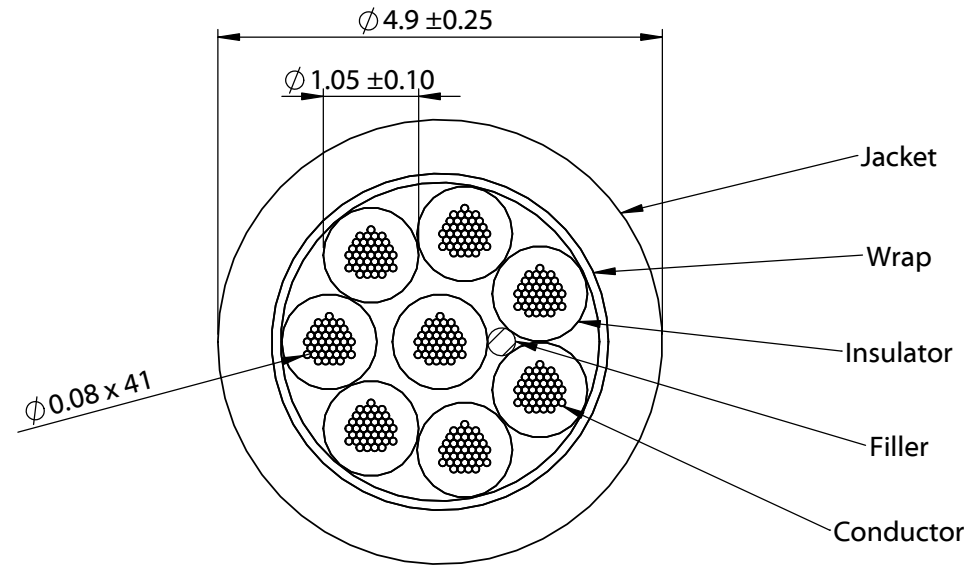
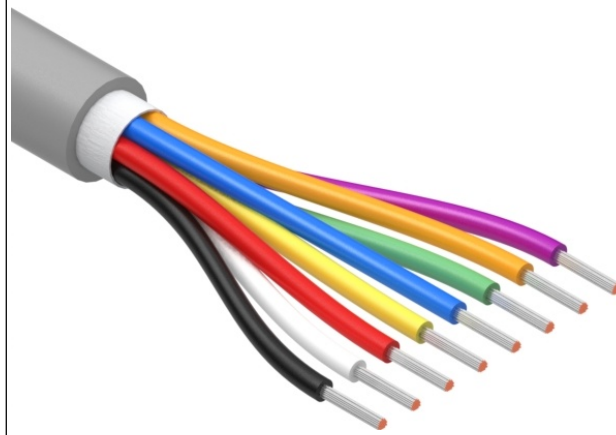

Revision:	Date:	Description:
A	8/24/2022	Initial release

Prepared:
PB
Digitally signed by PB
 Date: 2022.09.20
 10:58:57 -07'00'

Verified:
MP
Digitally signed by MP
 Date: 2022.09.21
 10:36:13 -07'00'

Dimensions are in millimeters.
 Tolerances:
 X: ± 0.5 mm
 X.X: ± 0.3 mm
 X.XX: ± 0.05 mm

Notes:

RoHS compliant
 Jacket meets ISO 10993 Biological Compatibility
 Phthalate and halogen free
 Function test: no open, no short, no intermittent

Description:
 Wire, 8C TS, 24 AWG, 150V, 70C, 4.9 mm, TPU, 75A, gray, WBL

TENSILITY

tel 1.541.323.3228 800 877.670.7118
 fax 1.541.323.4202 web tensility.com

Size:	Part number:
A	30-02753
Scale: 12:1	Sheet 1 of 1