

ZRT050

4.9V LOW POWER PRECISION REFERENCE SOURCE

DESCRIPTION

The ZRT050 is a monolithic integrated circuit providing a precise stable reference voltage of 4.9V at 500 μ A.

The circuit features a knee current of 150 μ A and operation over a wide range of temperatures and currents.

The ZRT050 is available in a SOT223 package for surface mount applications. This device offers a trim facility whereby the output voltage can be adjusted as shown in Fig.1. This facility is used when compensating for system errors or setting the reference output to a particular value. When the trim facility is not used, the pin should be left open circuit.

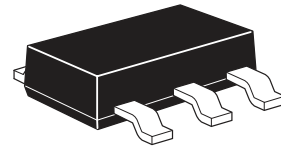

SOT223

FEATURES

- Trim mable output
- Excellent temperature stability
- Low output noise figure
- Available in two temperature ranges
- 1 and 2% initial voltage tolerance versions available
- No external stabilizing capacitor required in most cases
- Low slope resistance
- SOT223 small outline package

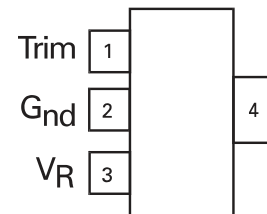

SOT223
Package suffix G
Top view (pin 4 floating or
connected to pin 2)

ORDERING INFORMATION

DEVICE	TOL%	OPERATING TEMP.	PACKAGE	PARTMARK
ZRT050GC2	2	-40 to 85°C	SOT223	ZRT050C2
ZRT050GC1	1	-40 to 85°C	SOT223	ZRT050C1
ZRT050GA1	1	-55 to 125°C	SOT223	ZRT050A1

A grade -55°C to 125°C
C grade -40°C to 85°C

ZRT050

ABSOLUTE MAXIMUM RATINGS

PARAMETER	SYMBOL	LIMIT	UNIT
Reverse current ⁽¹⁾		60	mA
Operating temperature: A grade	T _{OMP}	-55 to 125	°C
C grade		-40 to 85	°C
Storage temperature	T _{STG}	-55 to 150	°C

⁽¹⁾ Above 25°C this figure should be linearly derated to 12mA at 125°C

POWER DISSIPATION (at T_{amb} = 25°C unless otherwise stated)

PACKAGE	VALUE	UNIT
SOT223	2	W

TEMPERATURE DEPENDENT ELECTRICAL CHARACTERISTICS

SYMBOL	PARAMETER	INITIAL VOLTAGE TOLERANCE %	GRADE A		GRADE C		UNIT
			TYP	MAX	TYP	MAX	
ΔV _R	Output voltage change over relevant temperature range(See note (a))	1 & 2	13.5	45.0	5.4	17.2	mV
T _C V _R	Output voltage temperature coefficient (See note (b))	1 & 2	15.0	50.0	15.0	50.0	ppm/°C

ELECTRICAL CHARACTERISTICS (at T_{amb} = 25°C unless otherwise stated)

SYMBOL	PARAMETER	CONDITIONS	MIN.	TYP.	MAX.	UNIT
V _R	Output voltage	I _R =500μA	4.85	4.90	4.95	V
	1% tolerance (A1,C1)					
	2% tolerance (C2)		4.80	4.90	5.00	V
ΔV _{TRIM}	Output voltage adjustment range	R _T =100kΩ		±5		%
T _C ΔV _{TRIM}	Change in T _C V _R with output adjustment			2.5		ppm/°C/%
I _R	Operating current range	See note (c)	0.15		60	mA
t _{on}	Turn-on time	R _L =1kΩ		100		μs
t _{off}	Turn-off time			0.3		
e _{np-p}	Output voltage noise (over the range 0.1 to 10Hz)	Peak to peak measurement		50		μV
R _S	Slope resistance	I _R = 0.5mA to 5mA See note (d)		1.25	2.0	Ω

TYPICAL CHARACTERISTICS

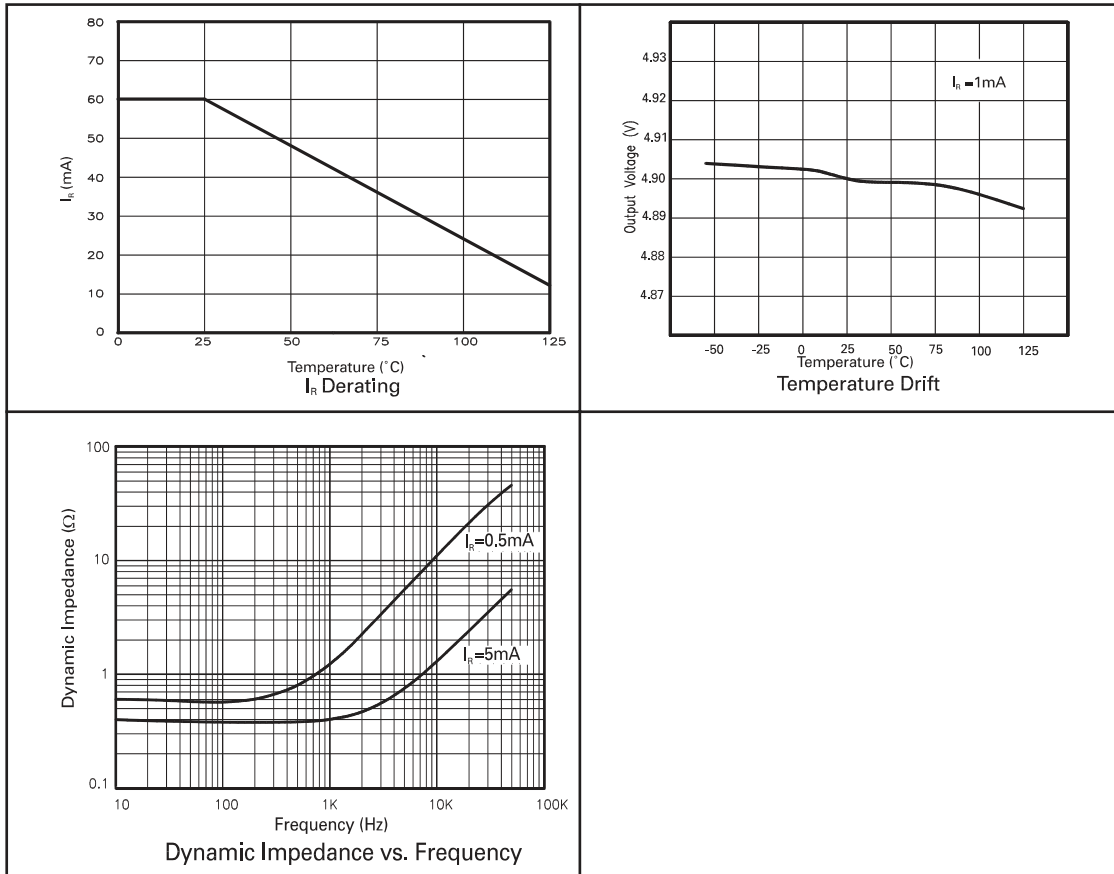

NOTES:

(a) Output change with temperature

The absolute maximum difference between the maximum output voltage and the minimum output voltage over the specified temperature range:

$$\Delta V_R = V_{max} - V_{min}$$

(b) Output temperature coefficient ($T_C V_R$)

The ratio of the output change with temperature to the specified temperature range expressed in ppm/°C:

$$T_C V_R = \frac{\Delta V_R \times 10^6}{V_R \times \Delta T} \text{ ppm}^\circ\text{C}$$

ΔT = Full temperature range

(c) Operating current (I_R)

Maximum operating current must be derated as indicated in maximum ratings.

(d) Slope resistance (R_S)

The slope resistance is defined as:

$$R_S = \frac{\text{change in } V_R}{\text{specific current range}}$$

$$\Delta I = 5 - 0.5 = 4.5 \text{ mA (typically)}$$

(e) Line regulation

The ratio of change in output voltage to the change in input voltage producing it:

$$\frac{R_S \times 100}{V_R \times R_{SOURCE}} \% / V$$

ZRT050

SCHEMATIC DIAGRAM

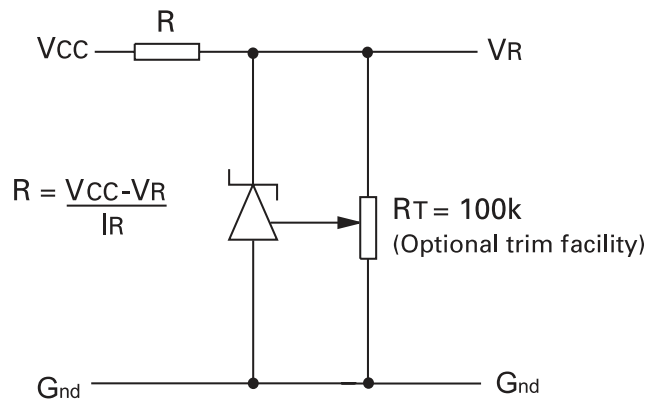
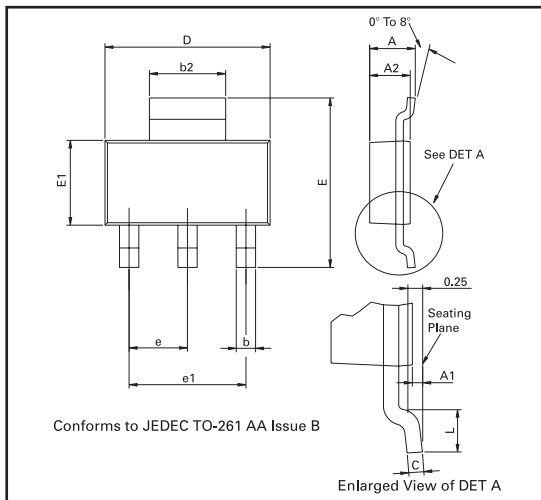

Figure 1:
This circuit will allow the reference to be trimmed over a wide range. The device is specified over a $\pm 5\%$ trim range.

ZRT050

PACKAGE OUTLINE



Controlling dimensions are in millimeters. Approximate conversions are given in inches

PACKAGE DIMENSIONS

DIM	Millimeters		Inches		DIM	Millimeters		Inches	
	Min	Max	Min	Max		Min	Max	Min	Max
A	–	1.80	–	0.071	e	2.30 BSC		0.0905 BSC	
A1	0.02	0.10	0.0008	0.004	e1	4.60 BSC		0.181 BSC	
b	0.66	0.84	0.026	0.033	E	6.70	7.30	0.264	0.287
b2	2.90	3.10	0.114	0.122	E1	3.30	3.70	0.130	0.146
C	0.23	0.33	0.009	0.013	L	0.90	–	0.0355	–
D	6.30	6.70	0.248	0.264		–	–	–	–

© Zetex plc 2003

Europe	Americas	Asia Pacific
Zetex plc Fields New Road Chadderton Oldham, OL9 8NP United Kingdom Telephone (44) 161 622 4444 Fax: (44) 161 622 4446 hq@zetex.com	Zetex GmbH Streitfeldstraße 19 D-81673 München Germany Telefon: (49) 89 45 49 49 0 Fax: (49) 89 45 49 49 49 europe.sales@zetex.com	Zetex (Asia) Ltd 3701-04 Metroplaza Tower 1 Hing Fong Road Kwai Fong Hong Kong Telephone: (852) 26100 611 Fax: (852) 24250 494 asia.sales@zetex.com
	Zetex Inc 700 Veterans Memorial Hwy Hauppauge, NY 11788 USA Telephone: (1) 631 360 2222 Fax: (1) 631 360 8222 usa.sales@zetex.com	

These offices are supported by agents and distributors in major countries world-wide.

This publication is issued to provide outline information only which (unless agreed by the Company in writing) may not be used, applied or reproduced for any purpose or form part of any order or contract or be regarded as a representation relating to the products or services concerned. The Company reserves the right to alter without notice the specification, design, price or conditions of supply of any product or service.

For the latest product information, log on to www.zetex.com

ISSUE 3 - DECEMBER 2003