

PRODUCT NUMBER	CONTACT AREA PLATING	PACKAGING
10122424-101LF	0.76µm Au	TAPE & REEL
10122424-901LF	0.38µm GXT	TAPE & REEL

NOTES:

- MATERIAL:  
HOUSING: HIGH PERFORMANCE RESINS, BLACK.  
CONTACT: COPPER ALLOY.
- PLATING:  
UNDERPLATE: 1.27µm MIN NICKEL OVER ALL  
SOLDER AREA: 2.54µm MIN TIN (LEAD FREE)  
MATING AREA: SEE PRODUCT NUMBER TABLE.
- DESIGNED TO CONFORM WITH SFP+ MSA SPECIFICATION.
- PRODUCT SPECIFICATION: GS-12-1141
- APPLICATION SPECIFICATION: GS-20-0385.
- PACKAGE SPECIFICATION: GS-14-2372
- PRODUCT MEETS EUROPEAN UNION DIRECTIVES AND OTHER COUNTRY REGULATIONS AS DESCRIBED IN GS-22-008.

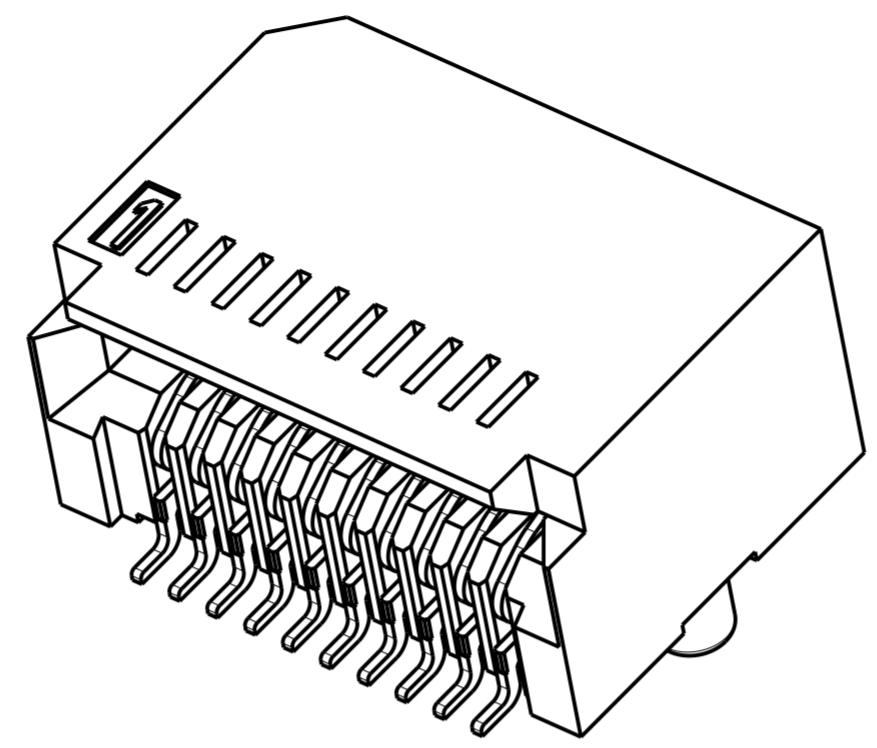
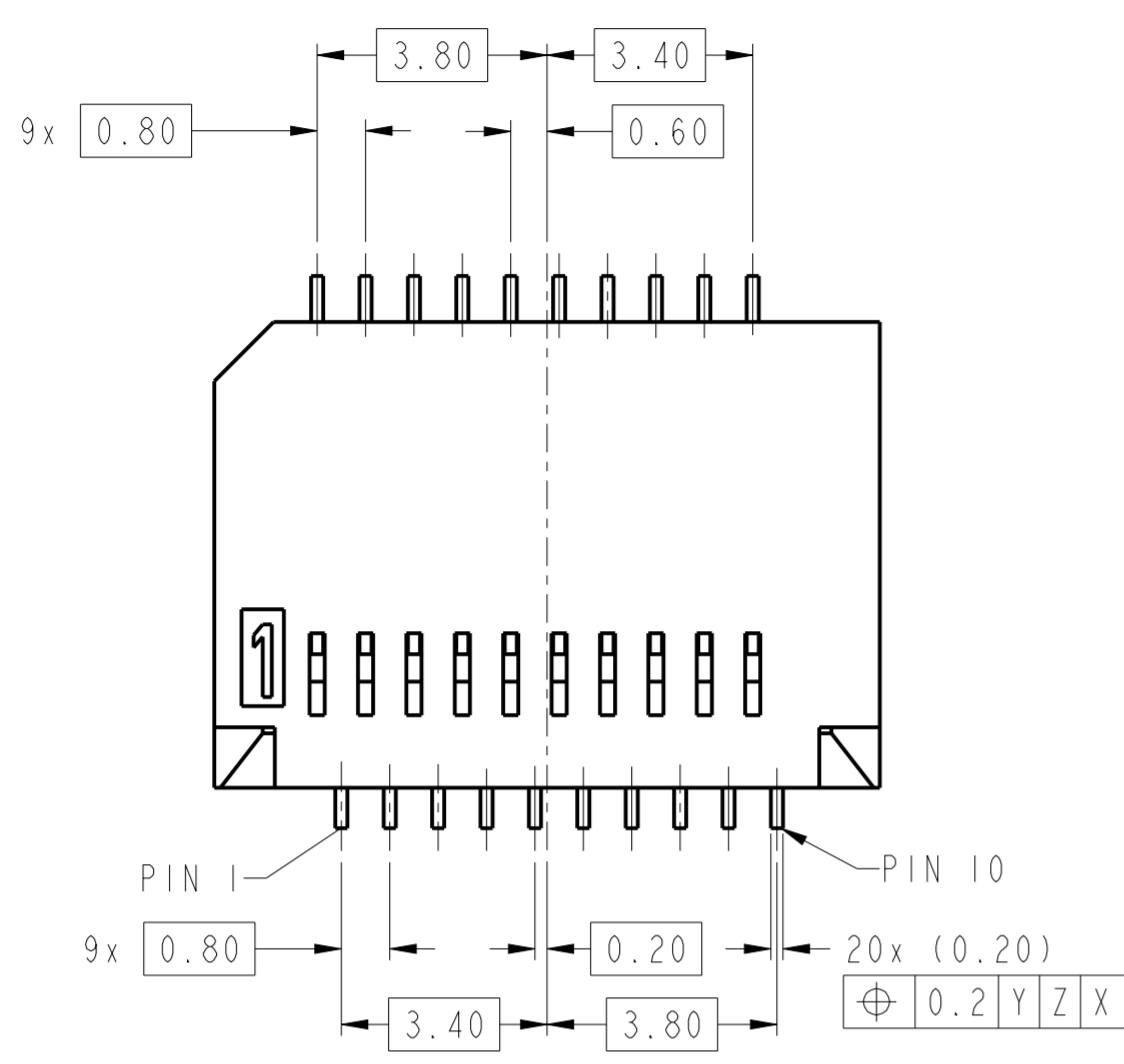

10122424-101LF/901LF 3D VIEW  
SCALE 8:1

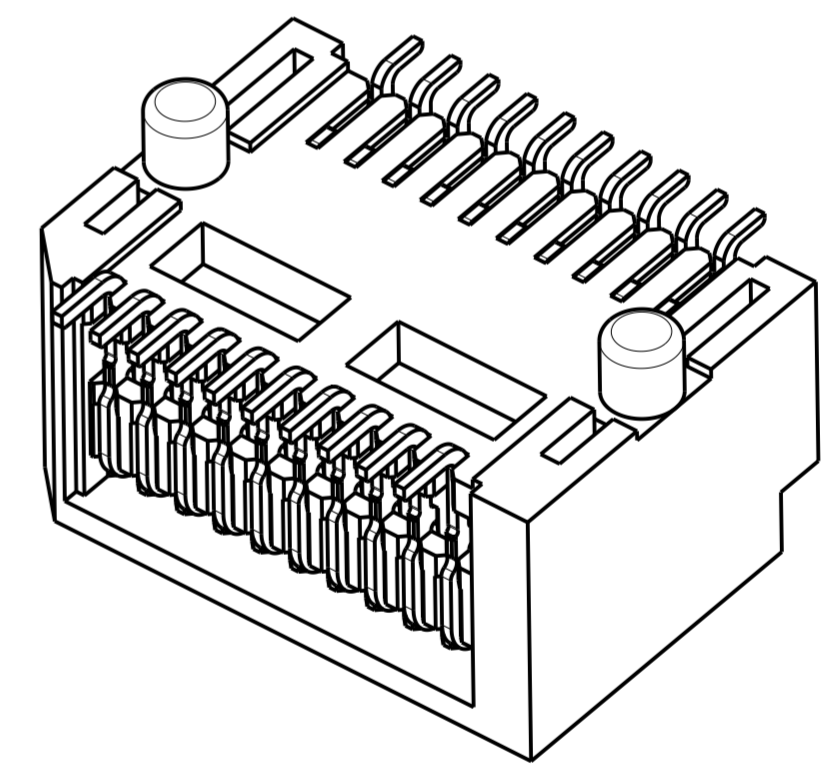
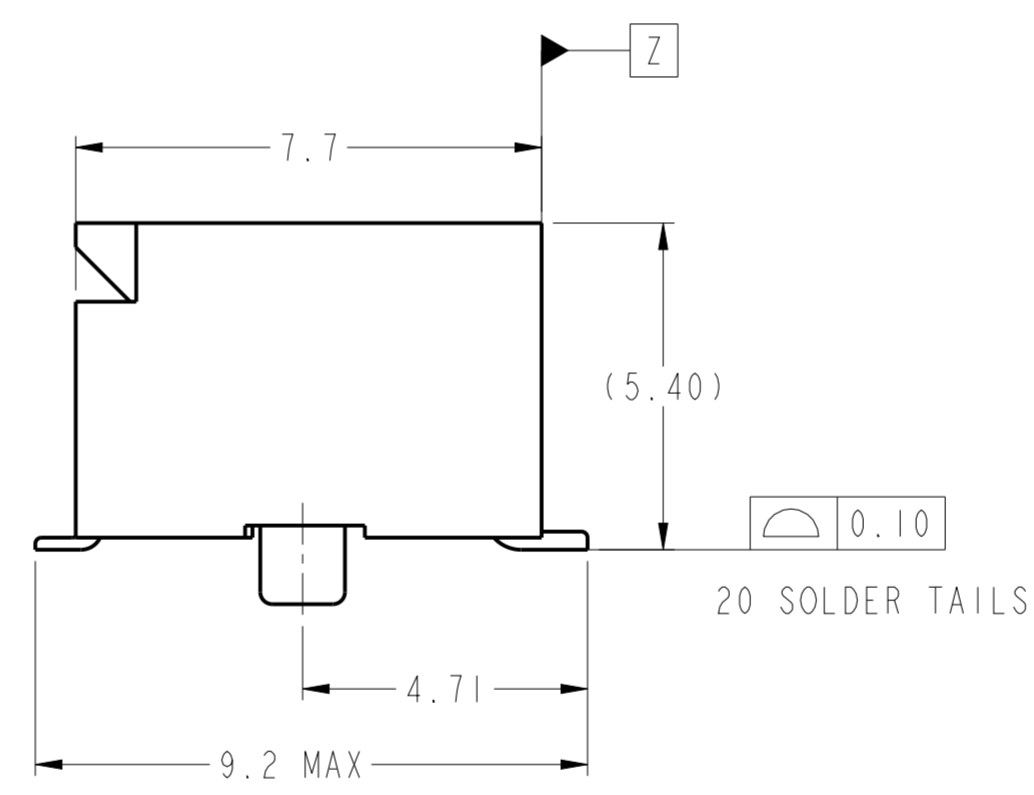
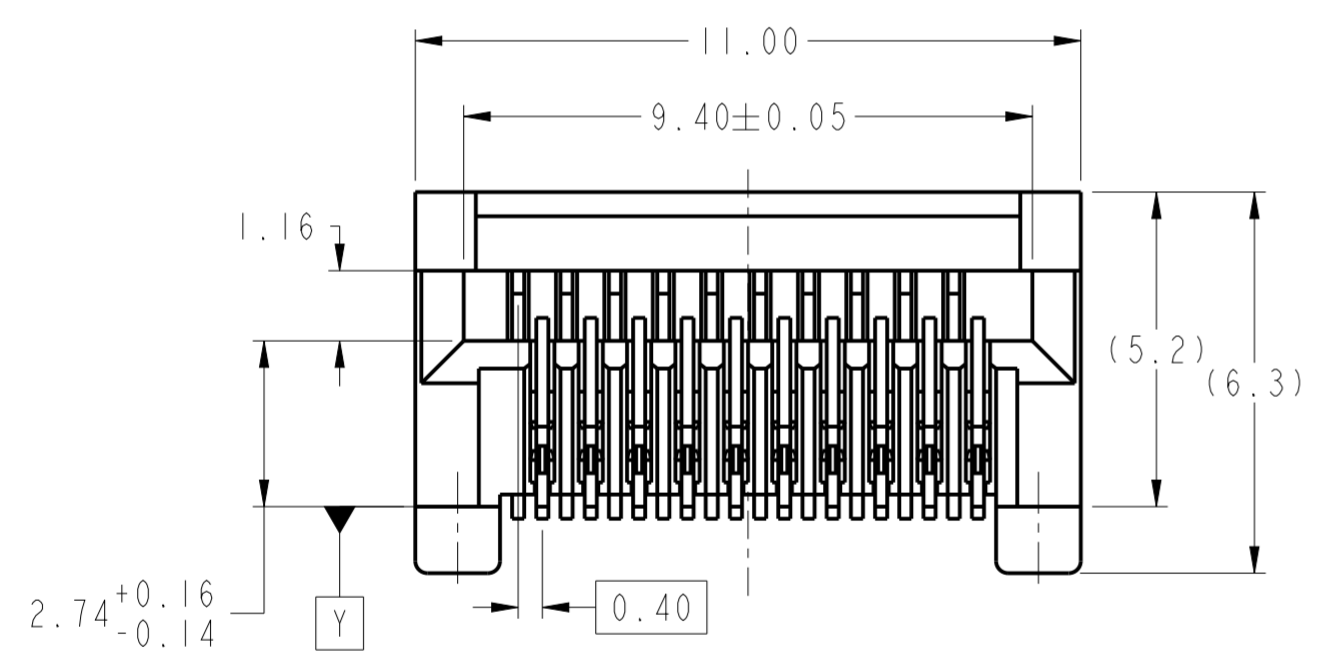

10122424-101LF/901LF 3D VIEW  
SCALE 8:1

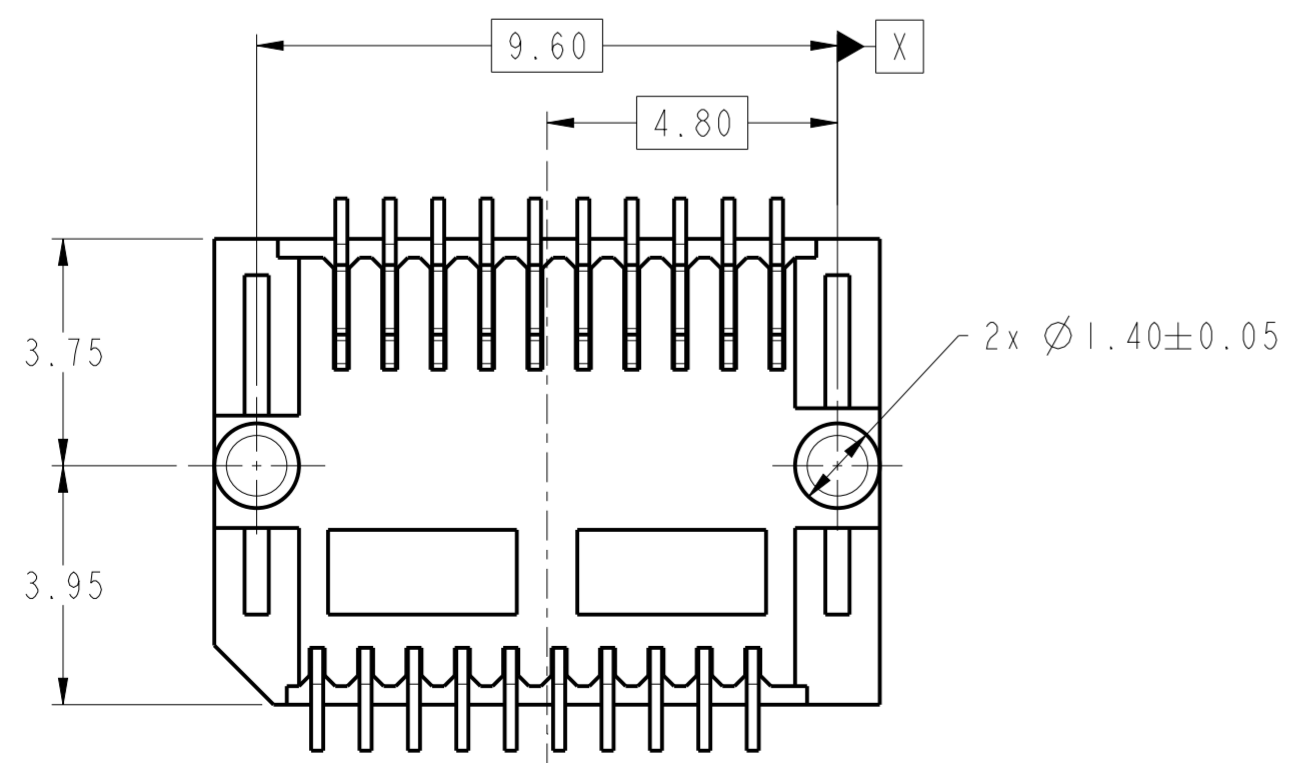

spec ref	-	dr	Zhen Luo	2013/09/30	projection	MM	size	A2	scale	1:1
tolerance std	ISO 406 ISO 1101	eng	Art Lin	2016/07/05			ecn no	ELX-DG-23846-1		
TOLERANCES UNLESS OTHERWISE SPECIFIED		chr	Zhen Luo	2016/07/21				rel level	Released	
surface	ISO 1302	appr	Pei-Ming Zheng	2016/07/21	product family	-	rel level	Released		
linear	0.X ±0.25 0.XX ±0.15 0.XXX ±0.05	Amphenol FCI		SFP+ BOARD CONNECTOR		cat. no.	10122424		rev	F
angular	0° ±2°	www.fci.com		SMT TYPE		Product - Customer Drw		sheet 1 of 3		

Amphenol FCI

© 2016 APCI

PRODUCT NUMBER	CONTACT AREA PLATING	PACKAGING
10122424-111LF	0.76µm Au	TAPE & REEL
10122424-911LF	0.38µm GXT	TAPE & REEL
10122424-112LF	0.76µm Au	ESD PACKING: TAPE & REEL with Custom Label on Reel

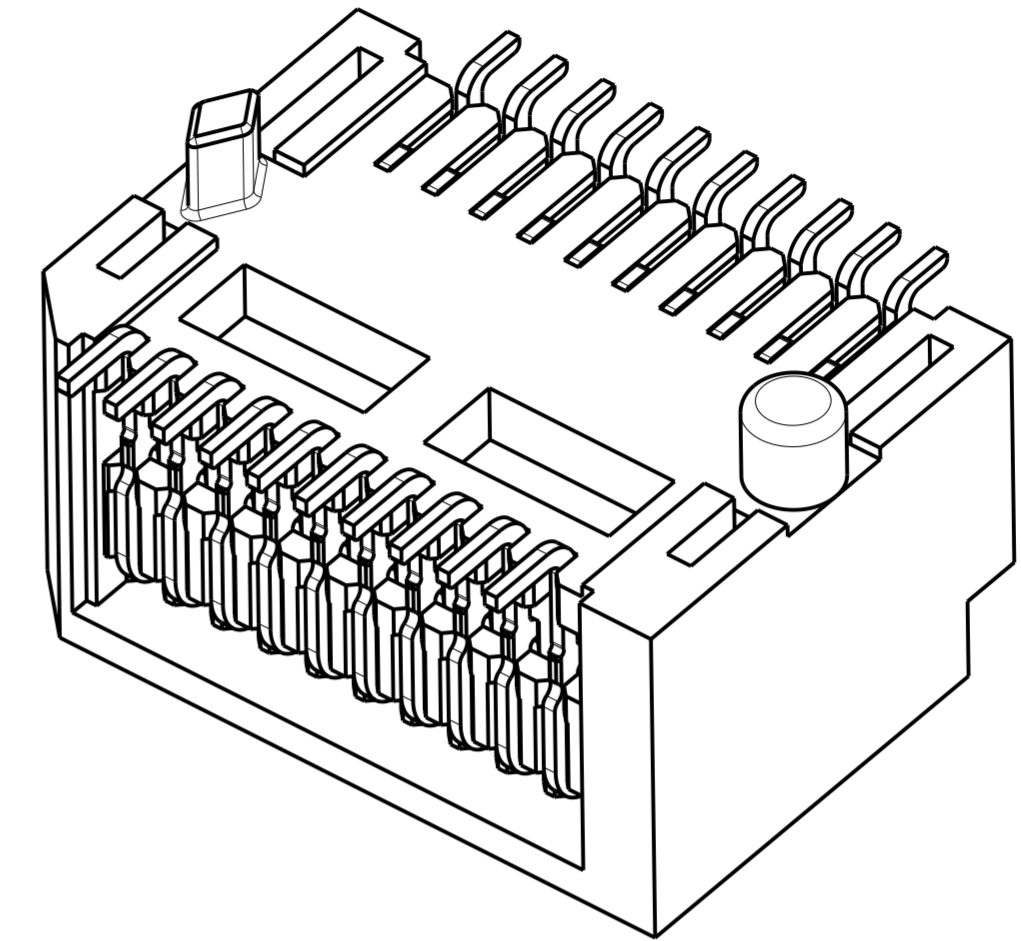
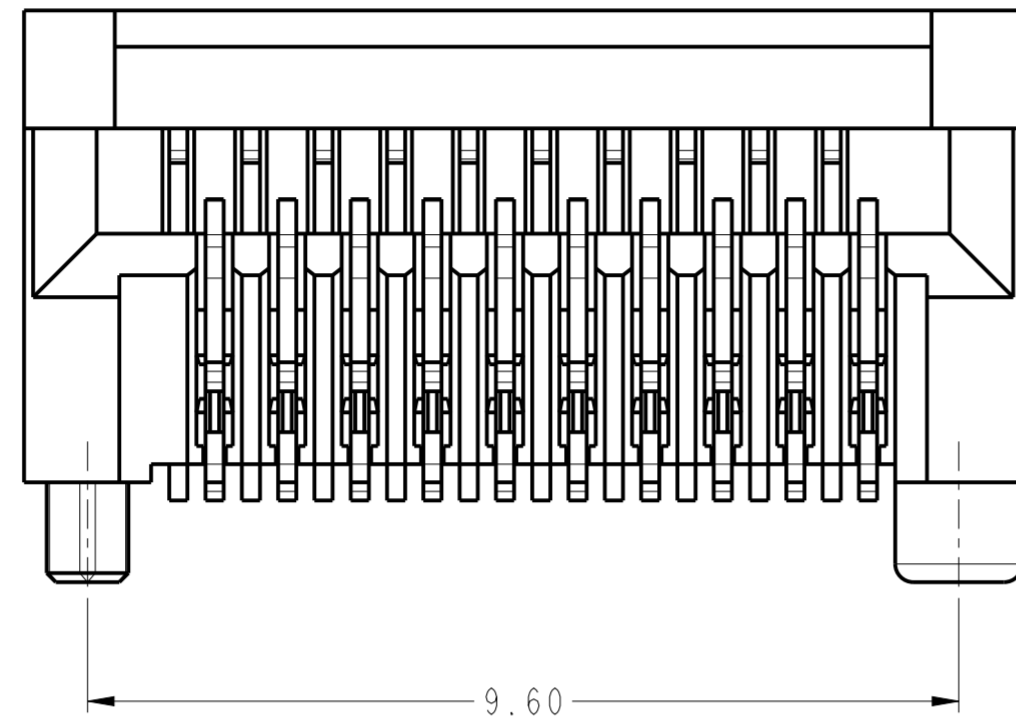

10122424-111LF/112LF/911LF 3D VIEW  
SCALE 10:1

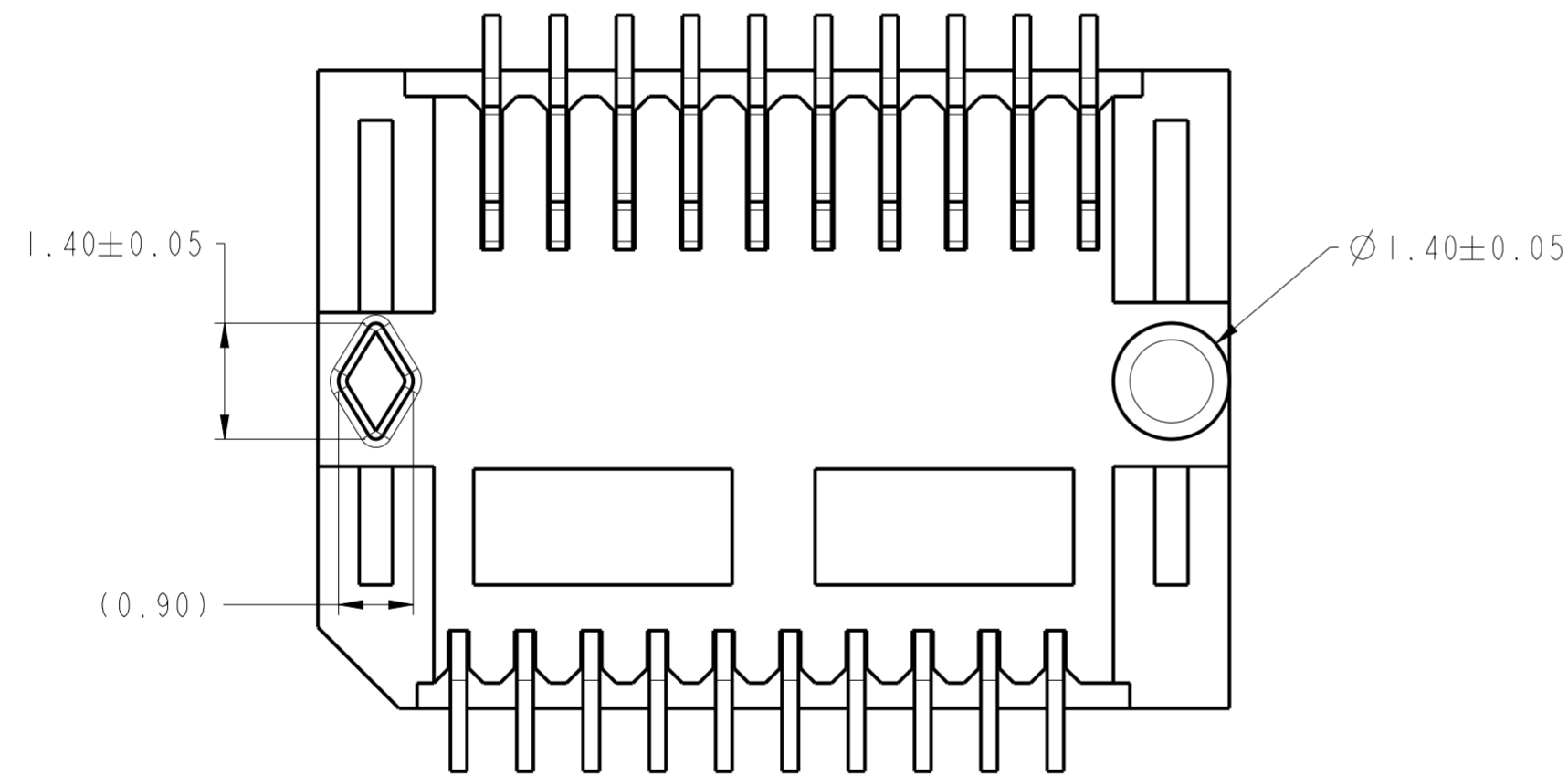

THE OTHER DIMENSIONS OF 10122424-111LF/112LF/911LF ARE SAME TO 10122424-101LF/901LF

Amphenol  
FCi

© 2016 APCI

spec ref	-	dr	Zhen Luo	2013/09/30	projection	MM	size	A2	scale	8:1
tolerance std	ISO 406 ISO 1101	eng	Art Lin	2016/07/05			ecn no	ELX-DG-23846-1		
TOLERANCES UNLESS OTHERWISE SPECIFIED		chr	Zhen Luo	2016/07/21			rel level	Released		
surface	ISO 1302	appr	Pei-Ming Zheng	2016/07/21	product family					
linear	0.X ±0.25 0.XX ±0.15 0.XXX ±0.05	Amphenol FCi		SFP+ BOARD CONNECTOR		dwg no	10122424		rev	F
angular	0° ±2°	www.fci.com		SMT TYPE		Product - Customer Drw		sheet 2 of 3		

PDS: Rev :F

STATUS:Released

Printed: Aug 03, 2016

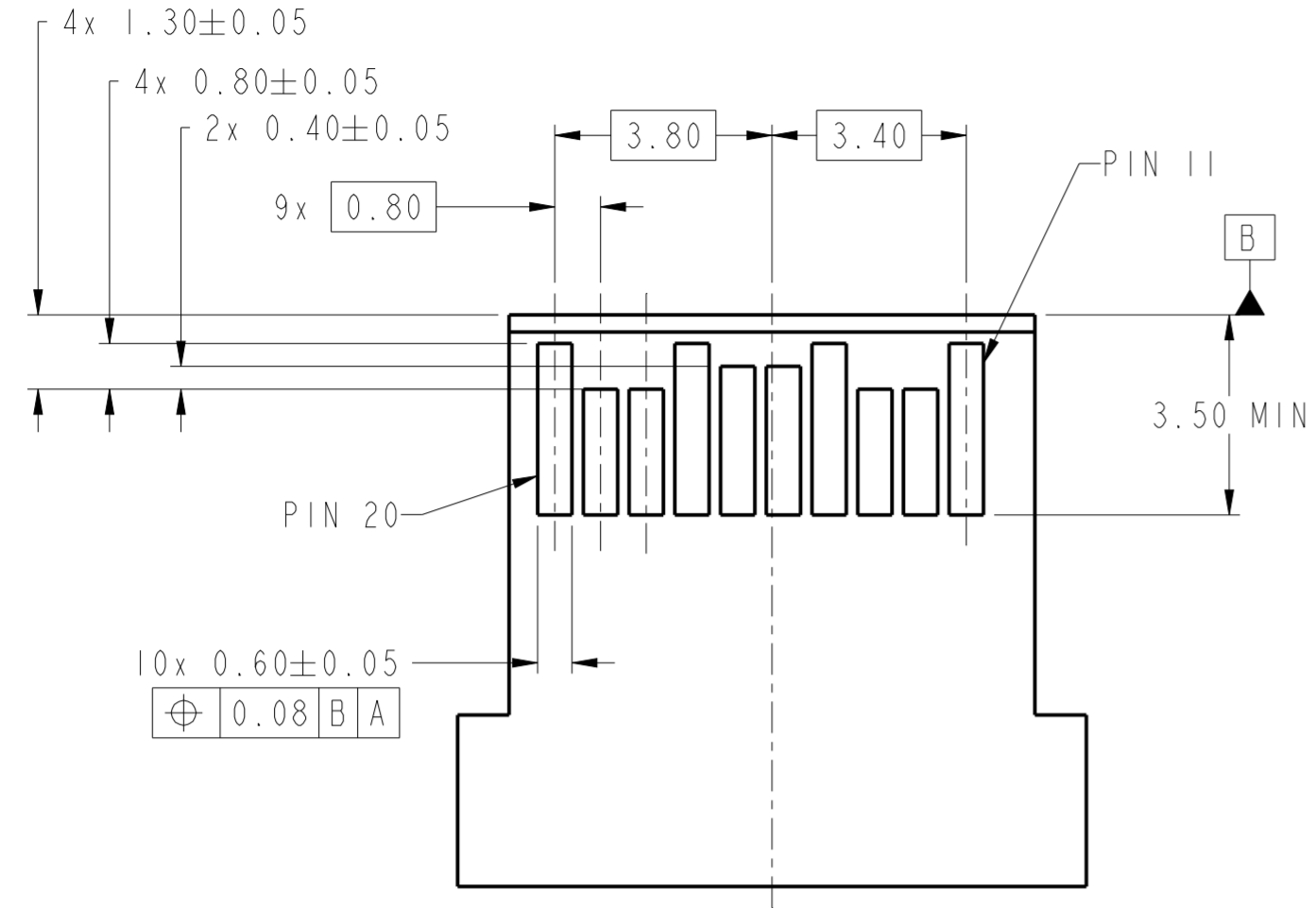

TOP VIEW OF BOARD

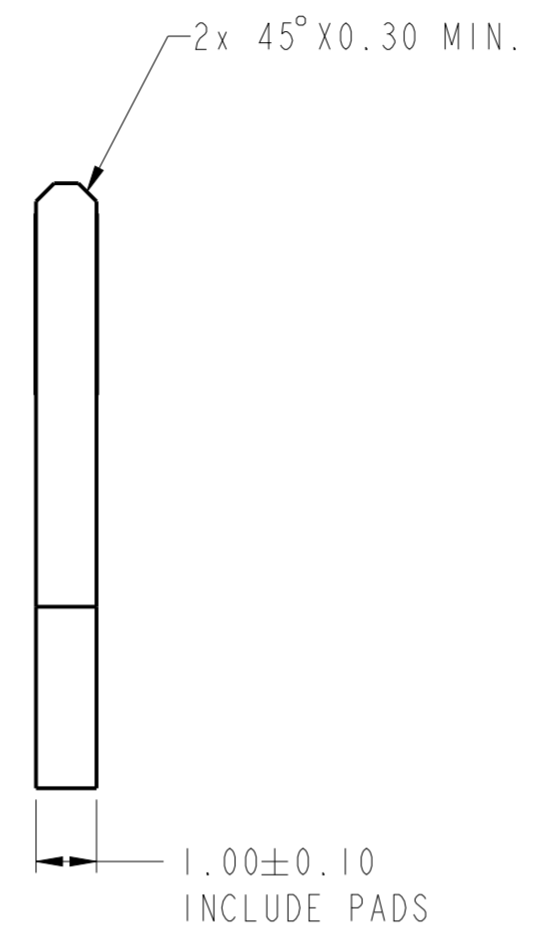

RECOMMENDED PCB LAYOUT  
MATING PCB SIDE

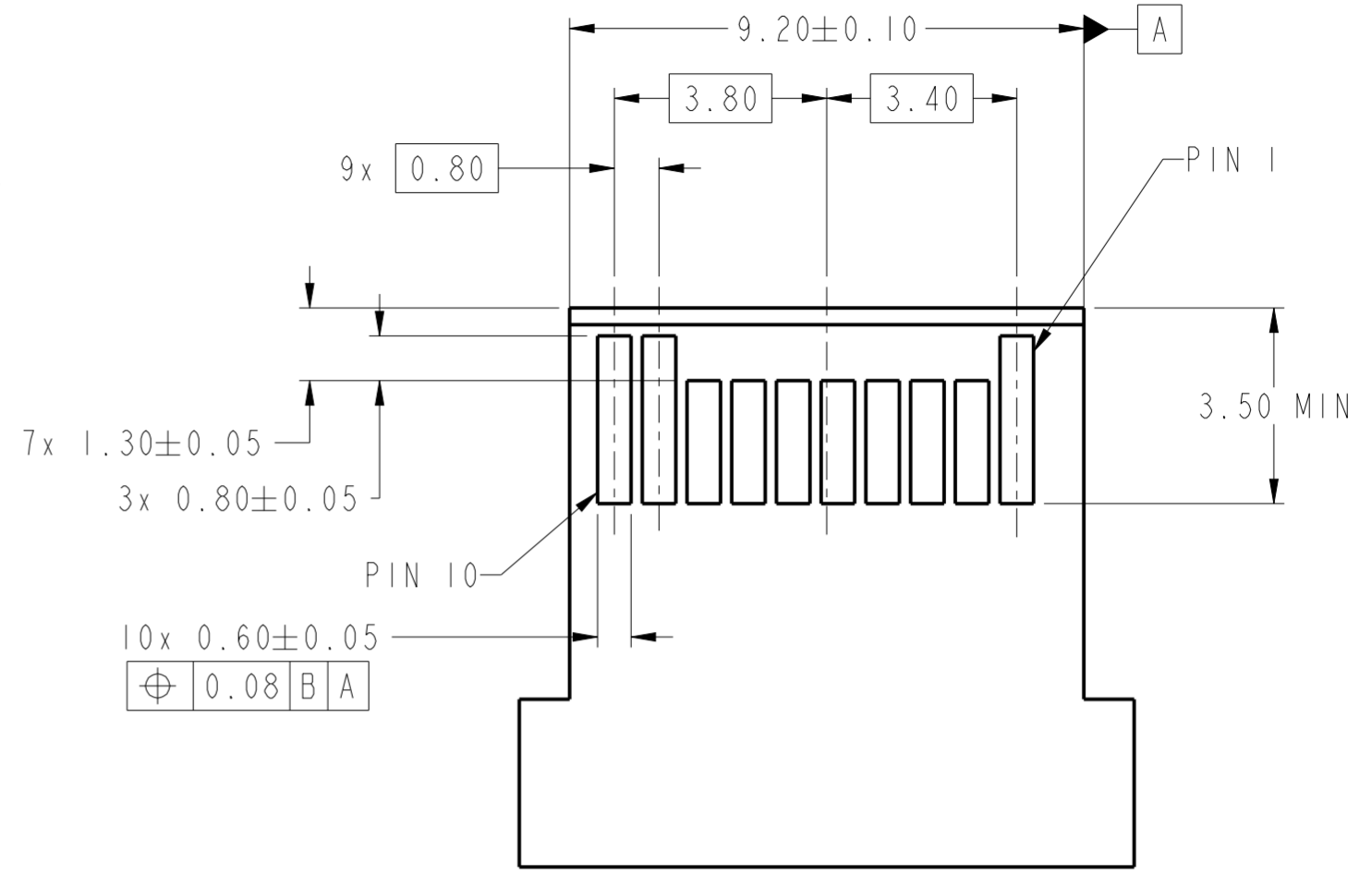

BOTTOM VIEW OF BOARD

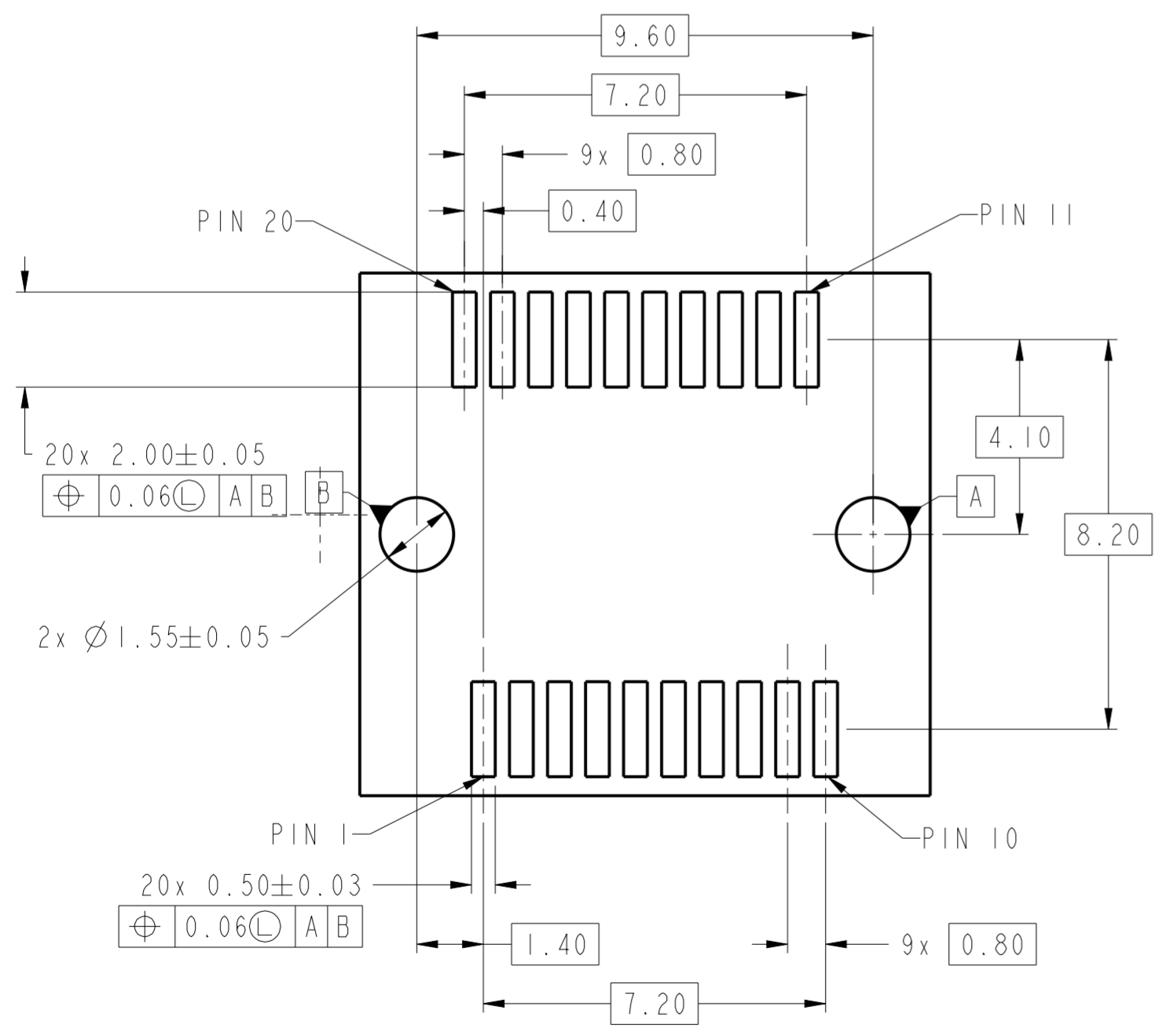

RECOMMENDED PCB LAYOUT  
CONNECTOR MOUNTING SIDE

spec ref	-	dr	Zhen Luo	2013/09/30	projection	MM	size	A2	scale	8:1
tolerance std	ISO 406 ISO 1101	eng	Art Lin	2016/07/05			ecn no	ELX-DG-23846-1		
TOLERANCES UNLESS OTHERWISE SPECIFIED		chr	Zhen Luo	2016/07/21			rel level	Released		
surface	ISO 1302	appr	Pei-Ming Zheng	2016/07/21	product family	SFP+ BOARD CONNECTOR		cat. no.	10122424	
linear	0.X ±0.25 0.XX ±0.15 0.XXX ±0.05	Amphenol FCI		SMT TYPE		dwg no	10122424		rev	F
angular	0° ±2°	www.fci.com		Product - Customer Drw		sheet 3 of 3		PDS: Rev : F		

Amphenol FCI

© 2016 APCI