

THIS DRAWING IS UNPUBLISHED. RELEASED FOR PUBLICATION, 19 .  
 © COPYRIGHT 19 BY AMP INCORPORATED. ALL INTERNATIONAL RIGHTS RESERVED.

LOC	DIST	P	F	ZONE	LTR	REVISIONS	DATE	APPD
AF	50				F	REV PER 0G3A-0402-01	22JUN01	JR/DD

1 CONTINUOUS STRIP ON REELS

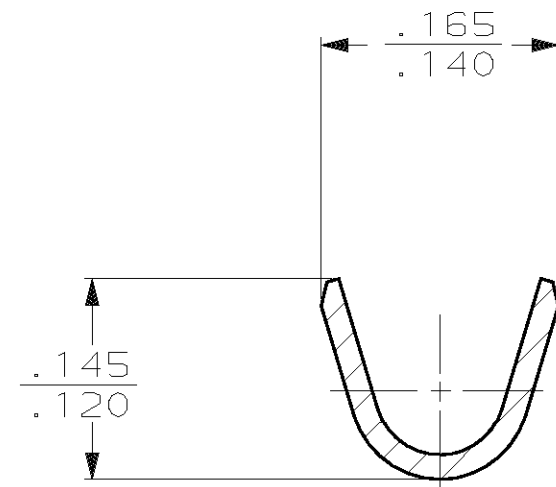
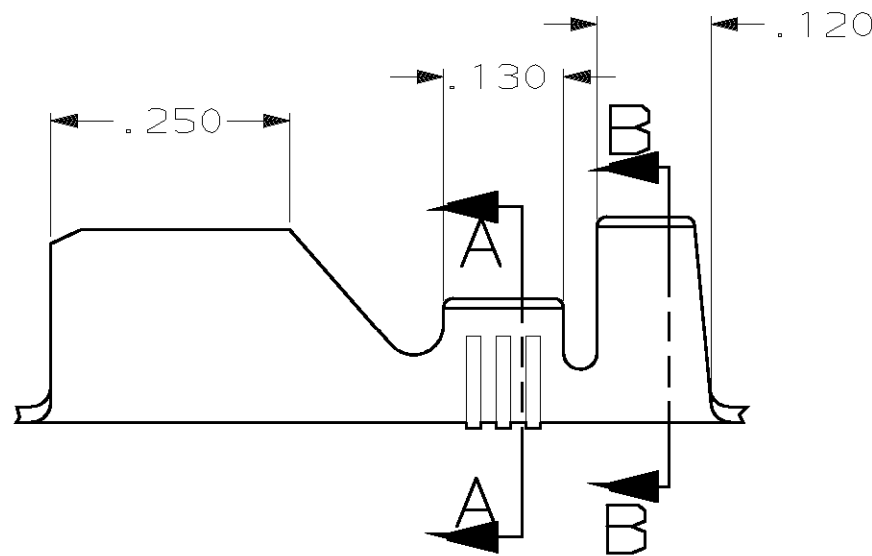
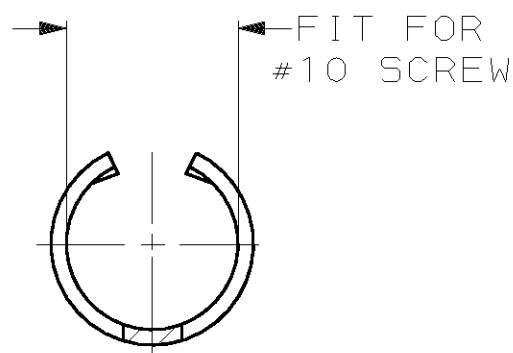
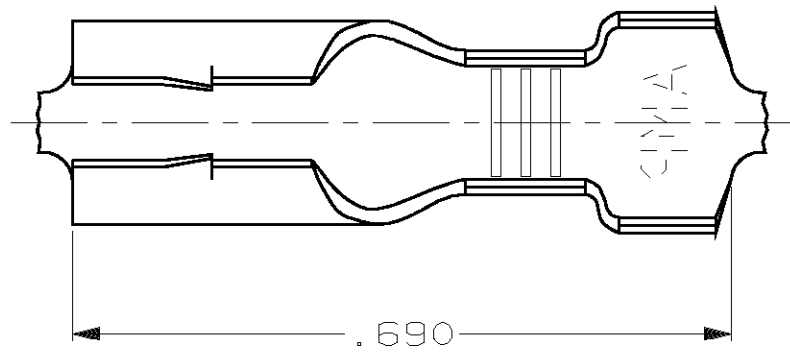

SECTION A-A  
SCALE 8:1

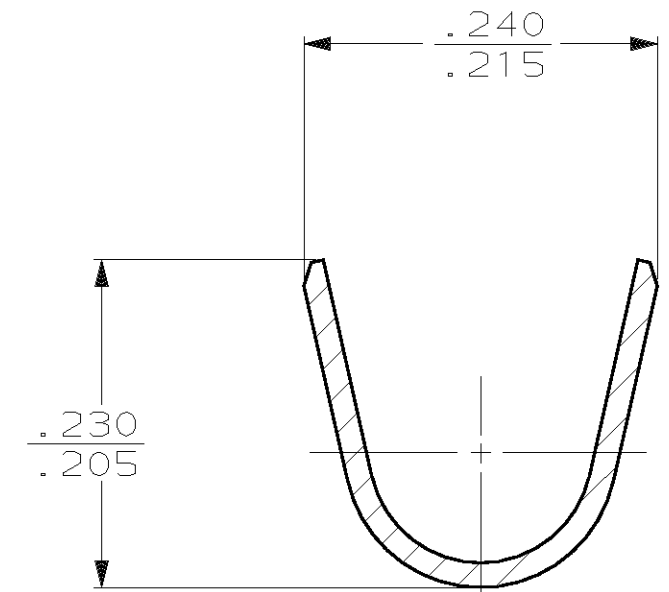

SECTION B-B  
SCALE 8:1

.130-.175 DIA	18-14 AWG	42308-1
INSULATION RANGE	WIRE SIZE	PART NO

0	.180	.200	F	.120	.067	14
					.059	16
					.053	18
TYPE	WIDTH	STRIP LENGTH ±.015	TYPE	WIDTH	±.002 HEIGHT	WIRE
INSUL BARREL CRIMP			WIRE BARREL CRIMP			

DO NOT SCALE PRINT. UNLESS SPECIFIED DIMENSIONS IN mm [INCHES] TOLERANCES ON: 2 PLC DEC ± - 3 PLC DEC ± .015 ANGLES ± -	DR 3/14/90 P FORTNEY
MATERIAL #4 HARD BRASS	CHK 3/14/90 JR RUTH
FINISH	APPD 3/14/90 G YETTER
	APPD 3/14/90 R KUZ0
	PRODUCT SPEC -
	APPLICATION SPEC -
	WEIGHT -

AMP INCORPORATED Harrisburg, Pa. 17105		
NAME PIN RECEPTACLE FOR #10 SCREW		
SIZE <b>B</b>	CAGE CODE 00779	DRAWING NO 42308
SCALE 6:1	SHEET 1 OF 1	