

Product Document

TSL3301CL

102 × 1 Linear Optical Sensor Array with Analog-to-Digital Converter

General Description

The TSL3301CL is a high-sensitivity 300-dpi, linear optical sensor array with integrated 8-bit analog-to-digital converters. The array consists of 102 pixels: 100 inner pixels and 2 end pixels. The inner pixels measure 85 μm (H) by 77 μm (W) on 85-μm centers and the end pixels are 132 μm (H) by 49 μm (W). Associated with each pixel is a charge integrator/amplifier and sample-hold circuit. All pixels have concurrent integration periods and sampling times. The array is split into three 34-pixel zones, with each zone having programmable gain and offset levels. Data communication is accomplished through a three-wire serial interface.

Intended for use in high performance, cost-sensitive scanner applications, the TSL3301CL is based on a linear sensor array die that has expanded capability, including multi-die addressing and cascade options. Please contact **ams** for additional information on die and multi-die package availability.

Ordering Information and Content Guide appear at end of datasheet.

Key Benefits & Features

The benefits and features of TSL3301CL, 102 × 1 Linear Optical Sensor Array with Analog-to-Digital Converter are listed below:

Figure 1:
Added Value Of Using TSL3301CL

Benefits	Features
<ul style="list-style-type: none"> Provides High Density Pixel Count 	<ul style="list-style-type: none"> 102 x 1 Sensor-Element Organization
<ul style="list-style-type: none"> Enables High Resolution Scanning 	<ul style="list-style-type: none"> 300 Dots-Per-Inch (DPI) Sensor Pitch
<ul style="list-style-type: none"> Provides Integrated Analog-to-Digital Conversion 	<ul style="list-style-type: none"> Digital Output
<ul style="list-style-type: none"> Enables Scalable Operating Range 	<ul style="list-style-type: none"> Programmable Gain

- High Sensitivity
- On-Chip 8-Bit Analog-to-Digital Conversion
- Three-Zone Programmable Offset (Dark Level) and Gain
- High Speed Serial Interface
- 1 MHz Pixel Rate
- Single 3V to 5.5V Supply

- Replacement for TSL3301
- RoHS Compliant

Block Diagram

The functional blocks of this device are shown below:

Figure 2:
TSL3301CL Block Diagram

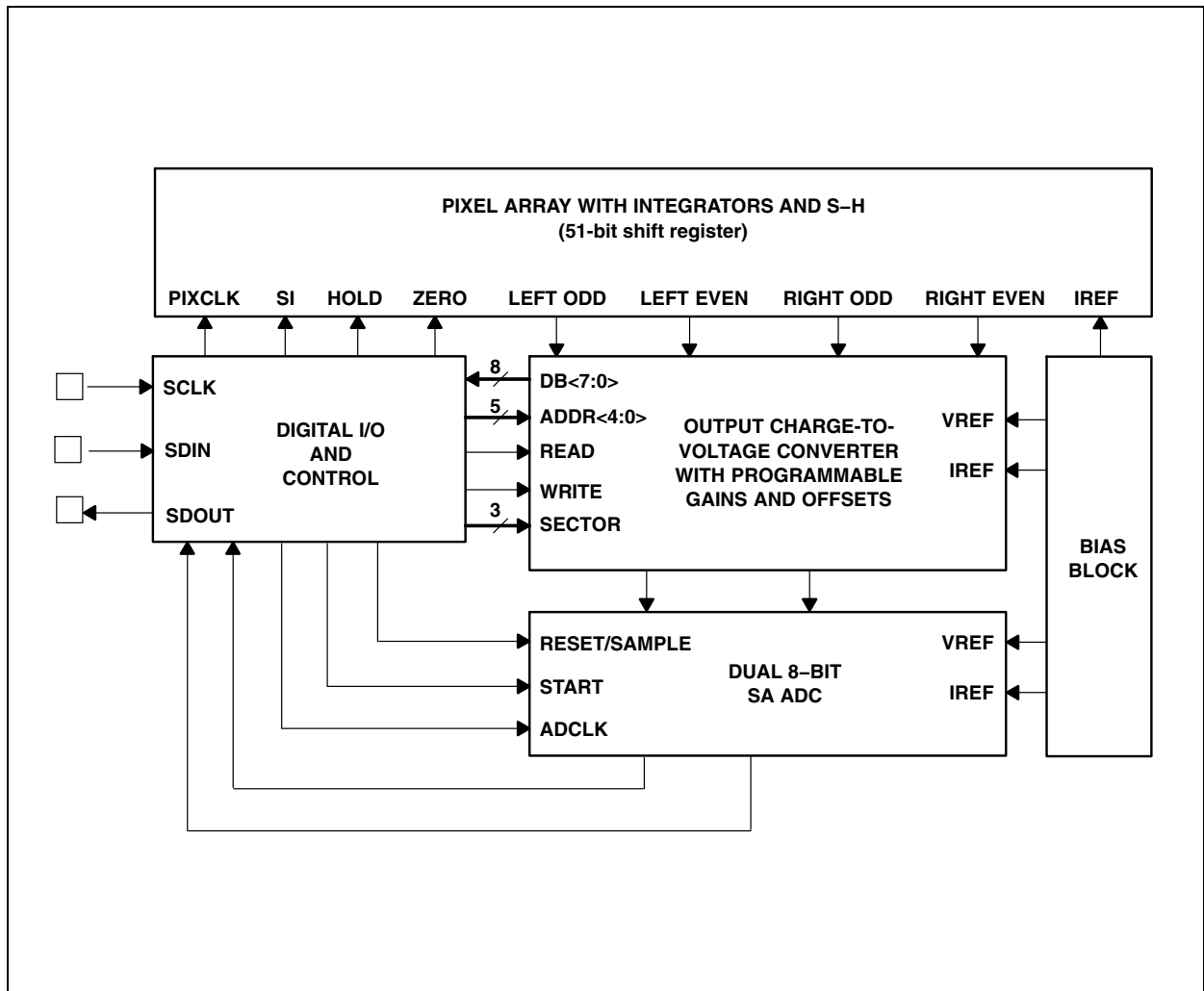

Pin Assignments

The TSL3301CL pin assignments are described below:

Figure 3:
CL Package (Top View)

CL Package (Top View):
NC - No internal connection
Package drawing not to scale

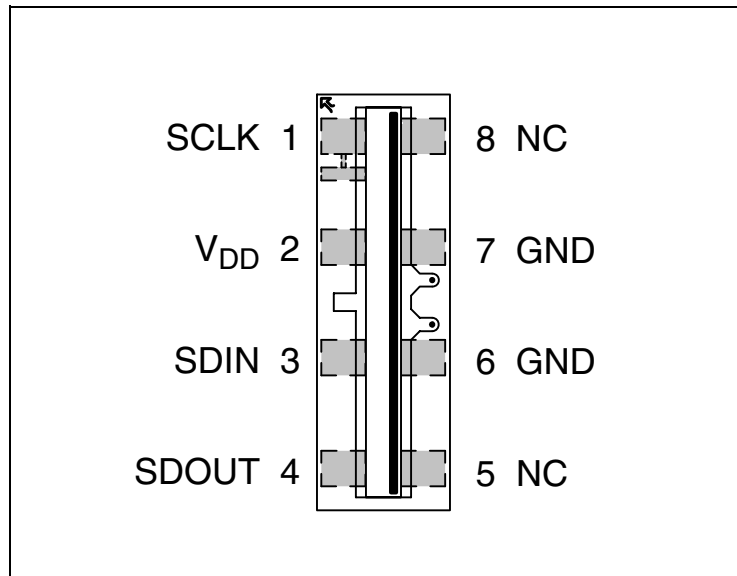

Figure 4:
Terminal Functions

Terminal		I/O	Description
Name	No		
GND	6,7		Ground
SCLK	1	I	System clock input for serial I/O and all internal logic.
SDIN	3	I	Serial data input. Data is clocked in on the rising edge of SCLK.
SDOUT	4	O	Serial data output. Data is clocked out on the falling edge of SCLK.
V _{DD}	2		Positive supply voltage.

Detailed Description

The TSL3301CL is a 102×1 linear optical array with onboard A/D conversion. It communicates over a serial digital interface and operates over a 3 V to 5.5 V range. The array is divided into three 34-pixel zones (left, center, and right), with each zone having programmable gain and offset (dark signal) correction.

The sensor consists of 102 photodiodes, also called pixels, arranged in a linear array. Light energy impinging on a pixel generates a photocurrent, which is then integrated by the active integration circuitry associated with that pixel. During the integration period, a sampling capacitor connects to the output of the integrator through an analog switch. The amount of charge accumulated at each pixel is directly proportional to the light intensity (E_e) on that pixel and to the integration time (t_{int}). At maximum programmed gain, one LSB corresponds to approximately 300 electrons.

Integration, sampling, output, and reset of the integrators are performed by the control logic in response to commands input via the SDIN pin. Data is read out on the SDOUT pin. A normal sequence of operation consists of a pixel reset (*RESET*), start of integration (*STARTInt*), integration period, sampling of integrators (*SAMPLEInt*), and pixel output (*READPixel*). Reset sets all the integrators to zero. Start of integration releases the integrators from the reset state and defines the beginning of the integration period. Sampling the integrators ends the integration period and stores the charge accumulated in each pixel in a sample and hold circuit. Reading the pixels causes the sampled value of each pixel to be converted to 8-bit digital format and output on the SDOUT pin. All 102 pixels are output sequentially unless interrupted by an abort (*ABORTPixel*) command or reset by a *RESET* command.

Gain adjustment is controlled by three 5-bit DACs, one for each of the three zones. Table 1 lists the gain settings and the corresponding pixel values. Offset is affected by the gain setting and may have to be adjusted after gain changes are made.

Offset correction¹ is controlled by three 8-bit sign-magnitude¹ DACs and is performed in the analog domain prior to the digital conversion. There is a separate offset DAC for each of the three zones. Codes 0h - 7Fh correspond to positive offset values and codes 80h - FFh correspond to negative offset values.

The offset correction is proportional to the gain setting. At minimal gain, one LSB of the offset DAC corresponds to approximately 1/3 LSB of the device output, and at maximum gain, to about 1 LSB of the device output.

Note that the gain and offset registers are in indeterminate states after power up and must be set by the controller as required.

1. Sign-magnitude is a binary representation in which the most significant bit (MSB) is used to represent the sign of the number, with the remaining bits representing the magnitude. An MSB of 1 indicates a negative number.

Figure 5:
Gain Settings and Results

Gain Code	Relative Gain	% Increase
0	1	
1	1.02	2.17
2	1.05	2.22
3	1.07	2.27
4	1.09	2.33
5	1.12	2.38
6	1.15	2.44
7	1.18	2.50
8	1.21	2.56
9	1.24	2.63
10	1.27	2.70
11	1.31	2.78
12	1.34	2.86
13	1.38	2.94
14	1.43	3.03
15	1.47	3.13
16	1.52	3.23
17	1.57	3.33
18	1.62	3.45
19	1.68	3.57
20	1.74	3.70
21	1.81	3.85
22	1.88	4.00
23	1.96	4.17
24	2.05	4.35
25	2.14	4.55
26	2.24	4.76
27	2.35	5.00
28	2.48	5.26

Gain Code	Relative Gain	% Increase
29	2.61	5.56
30	2.77	5.88
31	2.94	6.25

Serial Interface

The serial interface follows a USART format, with start bit, 8 data bits, and one or more stop bits. Data is clocked in synchronously on the rising edge of SCLK and clocked out on the falling edge of SCLK. Stop bits are not required on the input. When clocking data out continuously (i.e., reading out pixels) there will be one stop bit between data words.

The receive and transmit state machines are independent, which means commands can be issued while reading data. This feature allows starting new integration cycles while reading data. Note that this allows undefined conditions so care must be taken not to issue commands that will cause outputs (such as register read) while reading out data. For instance, issuing a register read command while reading out image data will result in garbage out. Likewise, it is possible to change offset and gain registers during a readout, which can give unpredictable results.

It is not necessary to have a continuously active clock, but a minimum of 5 clocks after the stop bit is required after any command has been issued to ensure that the corresponding internal logic actions have been completed. When reading register contents, there will be a 4-clock delay from the completion of the *REGRead* command before the register contents are output (see Figure 19). When reading out pixel values, there will be a 44-clock delay from completion of the *READPixel* command until the first pixel data is output. When starting integration (*STARTInt*), it is necessary to have 22 clocks to complete the pixel reset cycle (see *Imaging* below).

Register Address Map

The TSL3301CL contains seven registers as defined in Figure 6. Data in these registers may be written to or read from using the *REGWrite* and *REGRead* commands. Three registers control the gain of the analog-to-digital converters (ADC). Three other registers allow the offset of the system to be adjusted. Together the gain and offset registers are used to maximize the achievable dynamic range.

Figure 6:
Register Address Map

Address	Register Description	Register Width
0x00	Left (pixels 0–33) offset	8
0x01	Left (pixels 0–33) gain	5
0x02	Center (pixels 34–67) offset	8
0x03	Center (pixels 34–67) gain	5
0x04	Right (pixels 68–101) offset	8
0x05	Right (pixels 68–101) gain	5
0x1F	Mode	8

The offset registers are 8-bit sign-magnitude values and the gain registers are 5-bit values. The programmed offset correction is applied to the sampled energy, and then the gain is applied. (i.e., the gain will affect the offset correction.) These registers allow the user to maximize the dynamic range achievable in the given system.

The last register is the mode register. Bits in this register select the sleep mode as well as options for multichip arrays and production testing. Note that test and multichip options do not apply to the 8-pin packaged device. Users should always write 0s into the production test and multichip control bits.

Figure 7:
Mode Register Bit Assignments

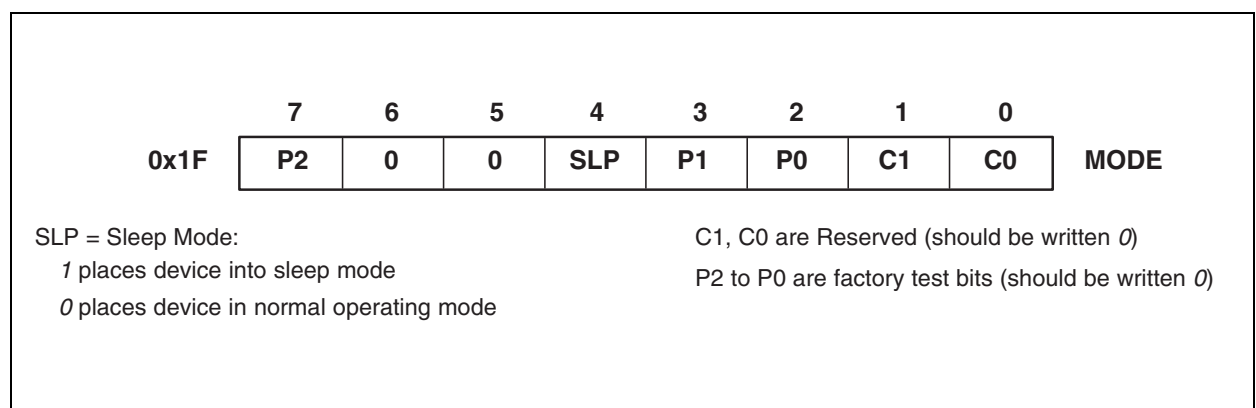

Command Description

The TSL3301CL is a slave device that reacts strictly to commands received from the digital controller. These commands cause the device to perform functions such as reset, integrate, sample, etc. [Figure 8](#) summarizes the command types and formats and [Figure 9](#) lists the command set for the TSL3301CL. Each command is described in more detail below.

Figure 8:
Command Type and Format Summary

Command Type	Format
Action command	< Command byte >
Register write	< Command byte > < Data byte >

Figure 9:
TSL3301CL Command Set

Command	Hex Code	Description
IRESET	SDIN held low for 30 clocks	Interface Reset
RESET	0x1B	Reset Integration and read blocks
STARTInt	0x08	Start pixel integration
SAMPLEInt	0x10	Stop light integration and sample results
READPixel	0x02	Dump serial the contents of each sampled integrator
ABORTPixel	0x19	Abort any READPixel operation in progress
READHold	0x12	Combination of SAMPLEInt and READPixel commands
READHoldNStart	0x16	Combination of SAMPLEInt, READPixel and STARTInt commands
REGWrite	0x40 + address	Write a gain, offset, or mode register
REGRead	0x60 + address	Read a gain, offset, or mode register

Programming Information

A minimum of 5 clock cycles after the stop bit is required after any command to ensure that the internal logic actions have been completed.

Reset Commands

Reset commands are used to put the TSL3301CL into a known state.

IRESET — *Interface Initialization*

Encoding: Break Character (10 or more consecutive start bits, or zeros)

The commands vary in length from one to three bytes. *IRESET* initializes the internal state machine that keeps track of which command bytes have been received. This command should be first and given only once after power-up to synchronize the TSL3301CL internal command interpreter.

An alternative is to issue three successive *RESET* commands.

RESET — *Main Reset*

Encoding: 0x1b: <0001_1011>

RESET resets most of the internal control logic of the TSL3301CL and any *READPixel* command currently in progress is aborted. *RESET* puts the pixel integrators into the auto-zero/reset state. Any values that were being held in the array's sample/hold circuits are lost.

Note(s): The value on the SDOOUT pin is not guaranteed from the time power is applied until 30 clocks after the first *RESET* command is issued.

Pixel Action Commands

Pixel action commands allow the user to control pixel integration and reading of pixel data.

STARTInt — *Start Integration*

Encoding: 0x08: <0000_1000>

STARTInt causes each pixel to leave the reset state and to start integrating light. The actual execution of *STARTInt* is delayed 22 clock cycles until the pixel reset cycle has been completed. (See *imaging* below.)

SAMPLEInt — *Stop Integration*

Encoding: 0x10: <0001_0000>

SAMPLEInt causes each pixel to store its integrator's contents into a sample and hold circuit. Also, the Integrator is returned to the reset state.

READPixel — Read Pixel Data

Encoding: 0x02: <0000_0010>

READPixel causes the sampled value of each pixel to be converted to an 8-bit digital value that is clocked out on the SDOOUT pin. The LSB is the first data bit, which is preceded by a START bit (logic 0) and followed by a STOP bit (logic 1). Each pixel in the device is presented on SDOOUT starting from pixel 00 and completes with pixel 101. There is a 44-clock cycle delay from the completion of the *READPixel* command until the first pixel data is output.

Gain and offset registers are used to adjust the ADC converter to maximize dynamic range and should be programmed prior to invoking the *READPixel* command.

ABORTPixel — Abort Pixel Data Read

Encoding: 0x19: <0001_1001>

ABORTPixel is an optional command that stops a *READPixel* command during its execution. It also causes pixel integration to terminate and the device to enter the auto-zero/reset state. Any values that were being held in the array's sample/hold circuits are lost.

READHold — Sample and Read Combination

Encoding: 0x12: <0001_0010>

READHold is a macro command that combines both the *SAMPLEInt* and *READPixel* commands into a single command.

READHoldNStart Combination

Encoding: 0x16: <0001_0110>

READHold is a macro command that combines the *SAMPLEInt*, *READPixel*, and *StartInt* commands into a single command. 22 clock cycles are necessary to complete the pixel reset cycle.

Register Commands

The register commands provide the user the capability of setting gain and offset corrections for each of the three zones of pixels. a4-a0 refer to the register address as given in [Figure 6](#).

REGWrite — Write a Gain/Offset/Mode Register

Encoding (2 bytes): 0x40 <data>: <010a4_a3a2a1a0>
<d7d6d5d4_d3d2d1d0>

REGWrite writes a value into either a gain, offset, or mode register. The 5-bit address of the register is encoded into the lower 5 bits of the command byte (the first byte). A second byte, which contains the data to be written, follows the command byte.

REGRead — Read a Gain/Offset/Mode Register

Encoding: 0x60: <011a4_a3a2a1a0>

REGRead reads the value previously stored in a gain, offset, or mode register. The 5-bit address of the register is encoded into the lower 5 bits of the command byte. Following receipt of the *REGRead* command, the device places the contents of the selected register onto the SDOOUT pin, LSB first.

There is a 4-clock cycle delay from the completion of the *REGRead* command until the register contents are output.

Operation

Initialization Sequence

After powering on the device, a minimum of 10 clocks with SDIN held high must be received by the TSL3301CL to clear the receiver logic so that a start bit will be detected correctly. The control logic may then be cleared by either issuing an *IRESET* command (break character) or 3 *RESET* (0x1b) commands. An additional 30 clocks must be received by the device to assure the state of SDO_{UT}.

Sleep Mode

The device can be put into a power down or sleep mode by writing a 0x10 to the mode register. This turns off all the analog circuitry on the chip. Normal operation is restored by writing a 0x00 to the mode register. The analog circuitry will require a minimum of 1 millisecond to recover from the sleep mode.²

Note that putting the device in the sleep mode does not affect the logic states of the machine. If, for example, a *READPixel* command is issued, the device will respond but the resulting data will be meaningless. Also note that 0x00 and 0x10 are the only two legitimate user programmable values for the single-chip version of the TSL3301CL. Other values may put the device into a non-operational mode.

2. For minimum sleep mode current consumption, voltage levels on logic inputs must be at either VDD or ground.

Imaging

After powering up the device and completing the initialization sequence, it is necessary to allow a minimum of 1 millisecond for the internal analog circuitry to settle. This delay is also required when coming out of the sleep mode.

Issuing a *STARTInt* (0x08) command will release the pixel integrators from the reset state. After an appropriate delay to integrate the image, the pixel data may be sampled by issuing a *SAMPLEInt* (0x10) command and then read out by issuing a *READPixel* (0x02) command.

A *STARTInt* command can be issued anytime after the *SAMPLEInt* command is issued to start another cycle. Thus, it is possible to be reading out one sample while integrating the next. However, the sampled data from the previous *SAMPLEInt* must be completely read out before the next *SAMPLEInt* command is issued.

The compound commands *READHold* (0x12) and *READHoldNStart* (0x16) are shortcut commands to simplify the imaging sequence.

It is important to note that a pixel reset sequence is initiated with the receipt of a *STARTInt* or *READHoldNStart* command. The next integration sequence cannot start until the pixel reset sequence has been completed, which requires 22 clocks **AFTER** the receipt of one of these commands. These clocks can also be used to clock commands or data into or out of the device.

Absolute Maximum Ratings

Stresses beyond those listed under [Absolute Maximum Ratings](#) may cause permanent damage to the device. These are stress ratings only, and functional operation of the device at these or any other conditions beyond those indicated under [Recommended Operating Conditions](#) is not implied. Exposure to absolute-maximum-rated conditions for extended periods may affect device reliability.

Figure 10:
Absolute Maximum Ratings Over Operating Free-Air Temperature Range (unless otherwise noted)

Symbol	Parameter	Min	Max	Units
V_{DD}	Supply voltage		6	V
V_O	Digital output voltage range	-0.3	$V_{DD} + 0.3$	V
	Digital output current	-10	+10	mA
I_I	Digital input current range	-20	20	mA
T_A	Operating free-air temperature range	-25	85	°C
T_{STRG}	Storage temperature range	-25	85	°C
ESD_{HBM}	ESD tolerance, human body model	±2000		V

Figure 11:
Recommended Operating Conditions

Symbol	Parameter	Min	Nom	Max	Units
V_{DD}	Supply voltage	3	5	5.5	V
V_{IH}	High-level input voltage at SCLK, SDIN	2		V_{DD}	V
V_{IL}	Low-level input voltage at SCLK, SDIN			0.8	V
	Power supply ripple, 100 kHz sawtooth waveform			60	mVp-p
	Input clock (SCLK) rise time, 10% to 90%			30	ns
T_J	Operating junction temperature	0		70	°C
f_{SCLK}	Maximum clock frequency			10	MHz

Electrical Characteristics

Figure 12:
Electrical Characteristics Over Recommended Operating Free-Air Temperature Range
 (unless otherwise noted)

Symbol	Parameter	Test Conditions	Min	Typ	Max	Unit	
V_{OH}	High level output voltage SDOOUT	$V_{DD} = 5\text{ V}$	$I_O = 50\ \mu\text{A}$	4.5	4.95		V
			$I_O = 4\ \text{mA}$		4.6		
		$V_{DD} = 3.3\text{V}$	$I_O = 50\ \mu\text{A}$		2.9		
			$I_O = 4\ \text{mA}$		2.7		
V_{OL}	Low level output voltage SDOOUT	$I_O = 50\ \mu\text{A}$			0.01	0.1	V
		$I_O = 4\ \text{mA}$			0.4		
I_{DD}	Supply current	A/D active			11	17	mA
		A/D inactive			6	11	
		Sleep mode				10	μA
V_{IL}	Low-level input voltage (SCLK, SDIN)				0.8	V	
V_{IH}	High-level input voltage (SCLK, SDIN)		2			V	
I_{IH}	High-level input current (SCLK, SDIN)	$V_I = V_{DD}$				± 10	μA
I_{IL}	Low-level input current (SCLK, SDIN)	$V_I = 0$				± 10	μA

Figure 13:
Light-to-Digital Transfer Characteristics at $V_{DD} = 5\text{ V}$, $T_J = 25^\circ\text{C}$, $\lambda_p = 660\text{ nm}$, $t_{int} = 250\ \mu\text{s}$
 (unless otherwise noted)

Parameter		Test Conditions	Min	Typ	Max	Unit
A-to-D converter resolution				8		bits
Full-scale reference	Gain register = 00000b			3.6		nJ/cm ²
	Gain register = 11111b			1.24		
Full-scale reference temperature sensitivity		For converter only, does not include photodiode characteristics		±150		ppm/°C
Average dark-level offset	Gain register = 00000b	Offset register = 00000000b	0	7	30	LSB
	Gain register = 11111b			20		
Dark signal nonuniformity (DSNU)		Gain register = 00000b, see Note ⁽¹⁾		5	10	LSB
		Gain register = 11111b, see Note ⁽¹⁾			14	
Average white level output	Offset register = 00000000b	Gain register = 00000b Ee = 11.3 μW/cm ²	160	200	240	LSB
		Gain register = 11111b Ee = 3.77 μW/cm ²		200		
Pixel-response non-uniformity (PRNU)		Ee = 11.3 μW/cm ² , See Notes ⁽²⁾ and ⁽³⁾		±8	±10	%
Programmable offset steps				±128		
Programmable offset step size	Gain register = 00000b			0.5		LSB
	Gain register = 11111b			1.5		
Dark-level change with temperature		0°C < T _J < 70°C		2		LSB
Differential nonlinearity				±0.5		LSB
Integral nonlinearity				±1		LSB

Parameter		Test Conditions	Min	Typ	Max	Unit
Dark level noise	Gain register = 00000b			0.5		LSB
	Gain register = 11111b			1.5		

Note(s):

1. DSNU is the difference between the highest value pixel and the lowest value pixel of the device under test when the array is not illuminated.
2. PRNU does not include DSNU.
3. PRNU is the difference between the highest value pixel and the lowest value pixel of the device under test when the array is uniformly illuminated at nominal white level (typical average output level = 200).

Figure 14:
Timing Requirements Over Recommended Operating Range (unless otherwise noted) (Figure 16)

Symbol	Parameter	Min	Nom	Max	Units
f_{max}	Maximum clock frequency	10			MHz
$t_{w(CLKH)}$	Clock high pulse duration	30			ns
$t_{w(CLKL)}$	Clock low pulse duration	30			ns
t_{su}	Input setup time	20			ns
t_h	Input hold time	20			ns

Figure 15:
Switching Characteristics Over Recommended Operating Range (unless otherwise noted) (Figure 17)

Symbol	Parameter	Test Conditions	Min	Nom	Max	Units
t_r	Rise time, output	$C_L = 20 \text{ pF}$		10		ns
t_f	Fall time, output			10		ns
t_d	Delay from clock edge to data-out stable			20		ns
C_i	Input pin capacitance			10		pF

Typical Operation Characteristics

Figure 16:
TSL3301CL Input Timing Requirements

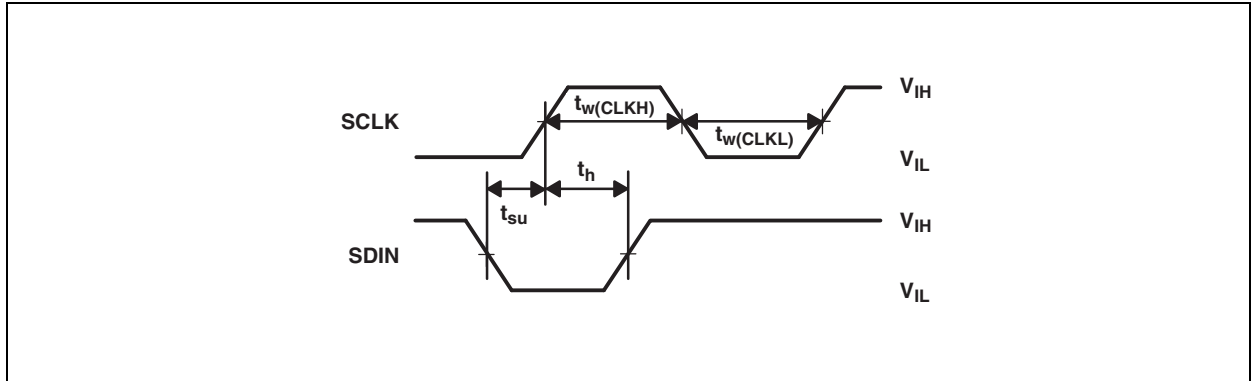

Figure 17:
TSL3301CL Output Switching Characteristics

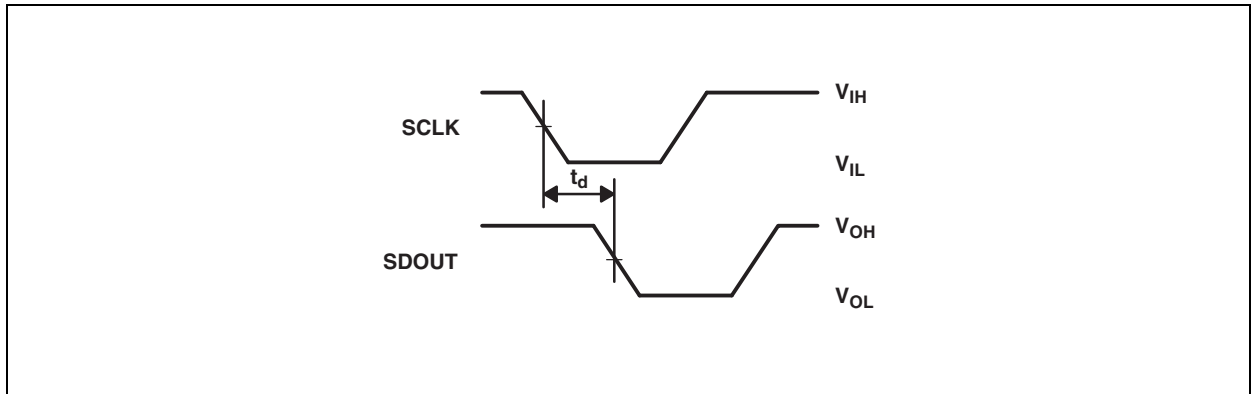

Figure 18:
TSL3301CL Serial I/O

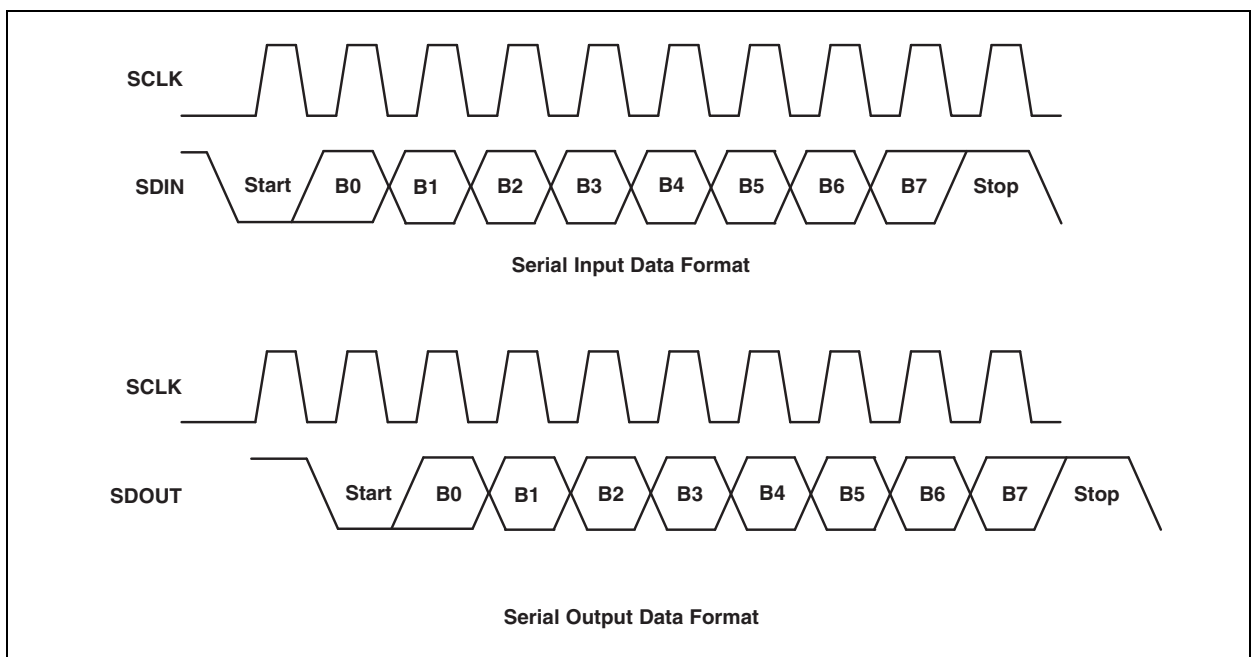

Figure 19:
TSL3301CL REGRead Output Response Timing

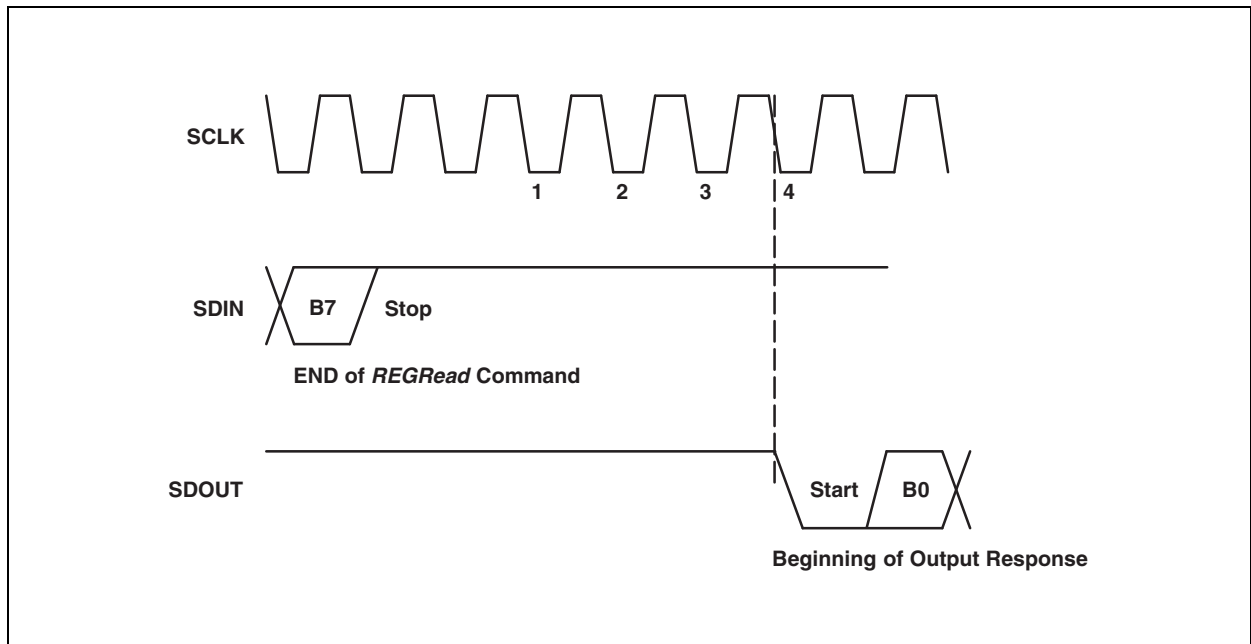
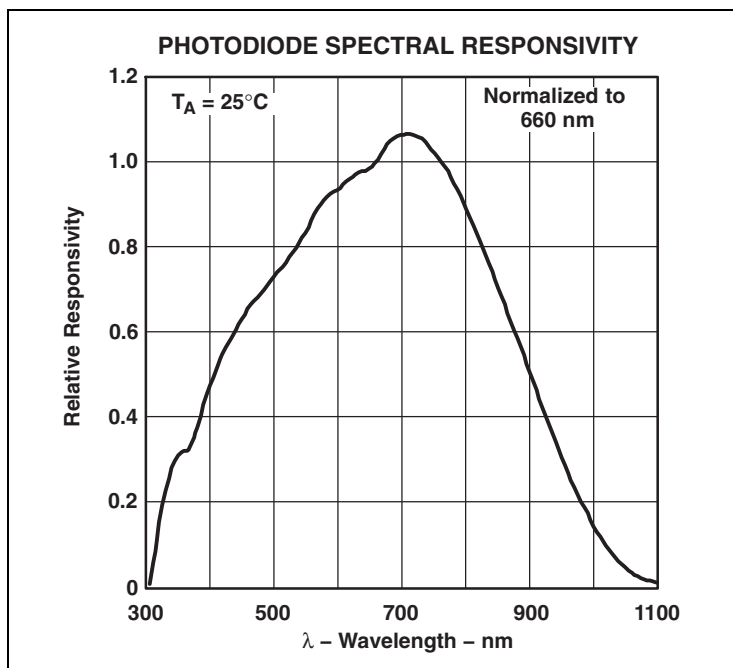

Figure 20:
TSL3301CL Photodiode Spectral Response



Application Information

Software

Normal Sequence

A typical programming sequence for the TSL3301CL device appears below:

```
Send(IRESET);
Send(RESET);
Calibration Cycle
*
*
while(1) {
    for(i=0;i<=2;i++) {/* for each pixel page */
        Write page gain register
        Write page offset register
        Read page gain register and verify (optional)
        Read page offset register and verify (optional)
    }
}
Send(STARTInt);
DelayIntegrationTime(); /* wait for appropriate time interval to elapse */
Send(SAMPLEInt);
Send(READPixel);
```

Hardware

PCB Pad Layout

Suggested PCB pad layout guidelines for the CL package are shown in [Figure 21](#).

Figure 21:
Suggested CL Package PCB Layout

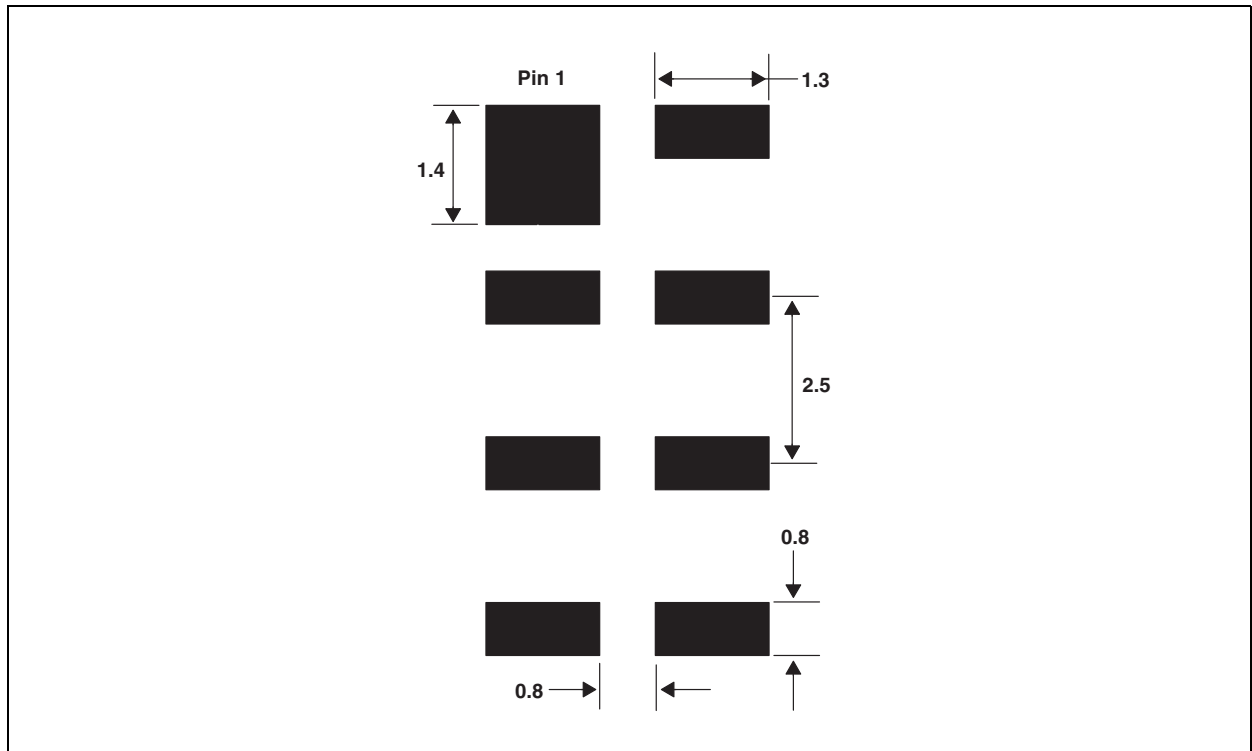

Note(s):

1. All linear dimensions are in millimeters.
2. This drawing is subject to change without notice.

Package Information

Figure 22:
Package CL Configuration

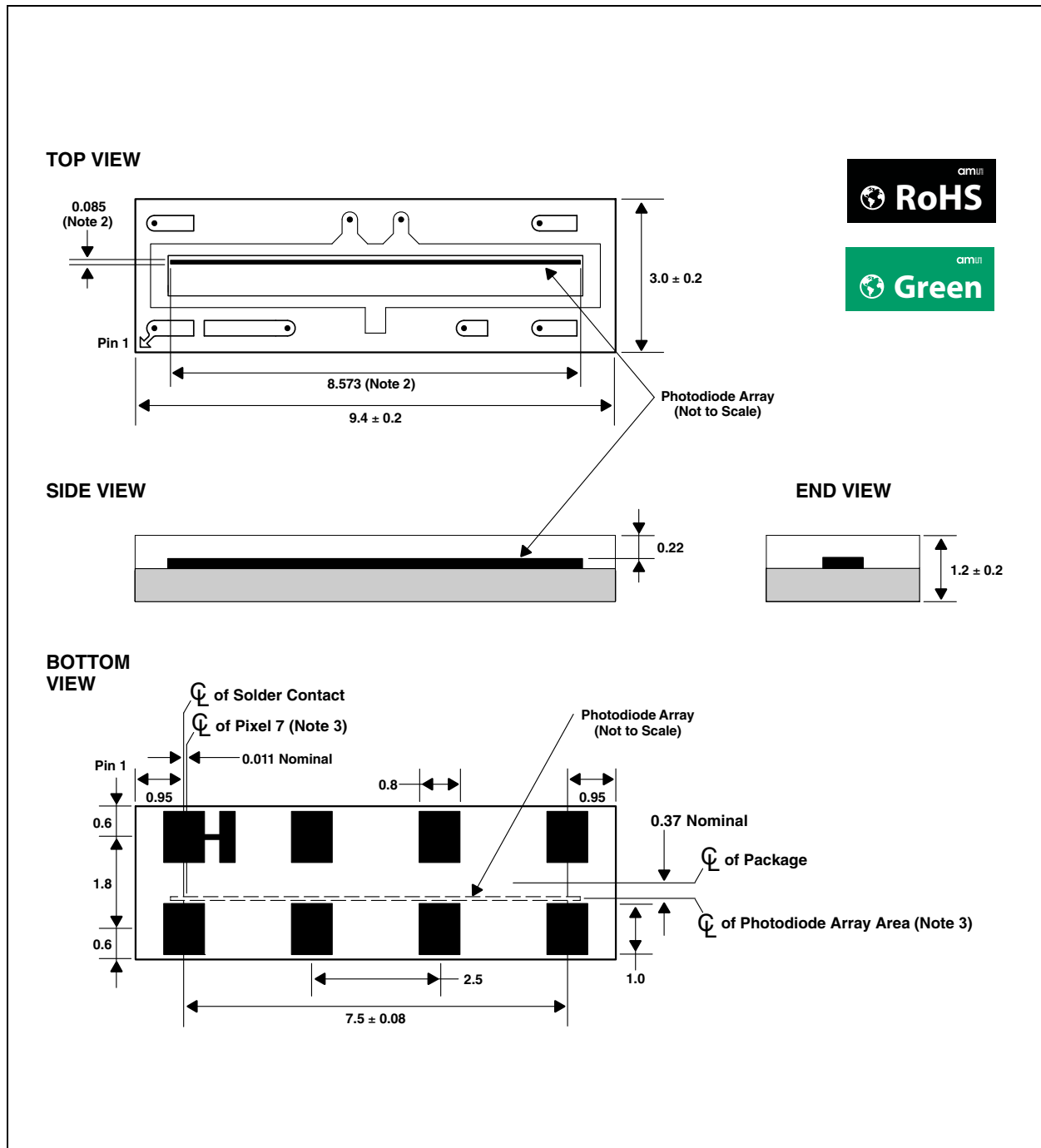

Note(s):

1. All linear dimensions are in millimeters. Dimension tolerance is ± 0.05 mm unless otherwise noted.
2. Nominal photodiode array dimension. The array is made up of 100 inner pixels and 2 end pixels with pixel #1 closer to Pin 1. The inner pixel is $77\mu\text{m}$ wide by $85\mu\text{m}$ high, spaced on $85\mu\text{m}$ centers. The end pixel is $49\mu\text{m}$ wide by $132\mu\text{m}$ high.
3. The die is centered within the package within a tolerance of ± 0.05 mm.
4. Package top surface is molded with an electrically nonconductive clear plastic compound having an index of refraction of 1.56.
5. Contact finish is soft gold plated.
6. This package contains no lead (Pb).
7. This drawing is subject to change without notice.

Figure 23:
Package CL Carrier Tape

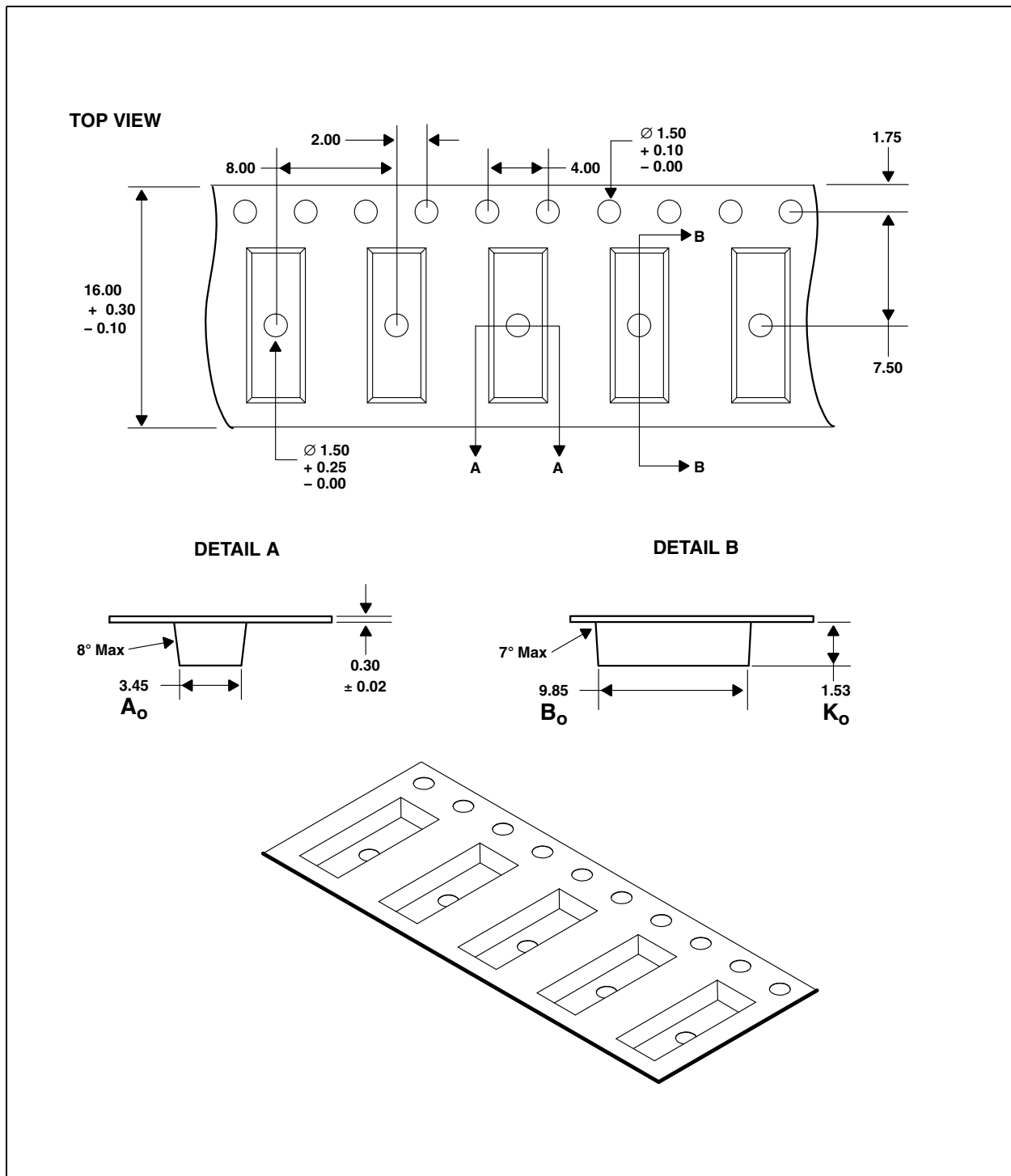

Note(s):

1. All linear dimensions are in millimeters. Dimension tolerance is ± 0.10 mm unless otherwise noted.
2. The dimensions on this drawing are for illustrative purposes only. Dimensions of an actual carrier may vary slightly.
3. Symbols on drawing A_0 , B_0 , and K_0 are defined in ANSI EIA Standard 481-B 2001.
4. Each reel is 178 millimeters in diameter and contains 1000 parts.
5. **ams** packaging tape and reel conform to the requirements of EIA Standard 481-B.
6. In accordance with EIA standard, device pin 1 is located next to the sprocket holes in the tape.
7. This drawing is subject to change without notice.

Soldering Information

The CL package has been tested and has demonstrated an ability to be reflow soldered to a PCB substrate.

The solder reflow profile describes the expected maximum heat exposure of components during the solder reflow process of product on a PCB. Temperature is measured on top of component. The components should be limited to a maximum of three passes through this solder reflow profile.

Figure 24:
Solder Reflow Profile

Parameter	Reference	Device
Average temperature gradient in preheating		2.5°C/s
Soak time	t_{soak}	2 to 3 minutes
Time above 217°C (T1)	t_1	Max 60 s
Time above 230°C (T2)	t_2	Max 50 s
Time above $T_{peak} - 10^\circ\text{C}$ (T3)	t_3	Max 10 s
Peak temperature in reflow	T_{peak}	260°C
Temperature gradient in cooling		Max -5°C/s

Figure 25:
Solder Reflow Profile Graph

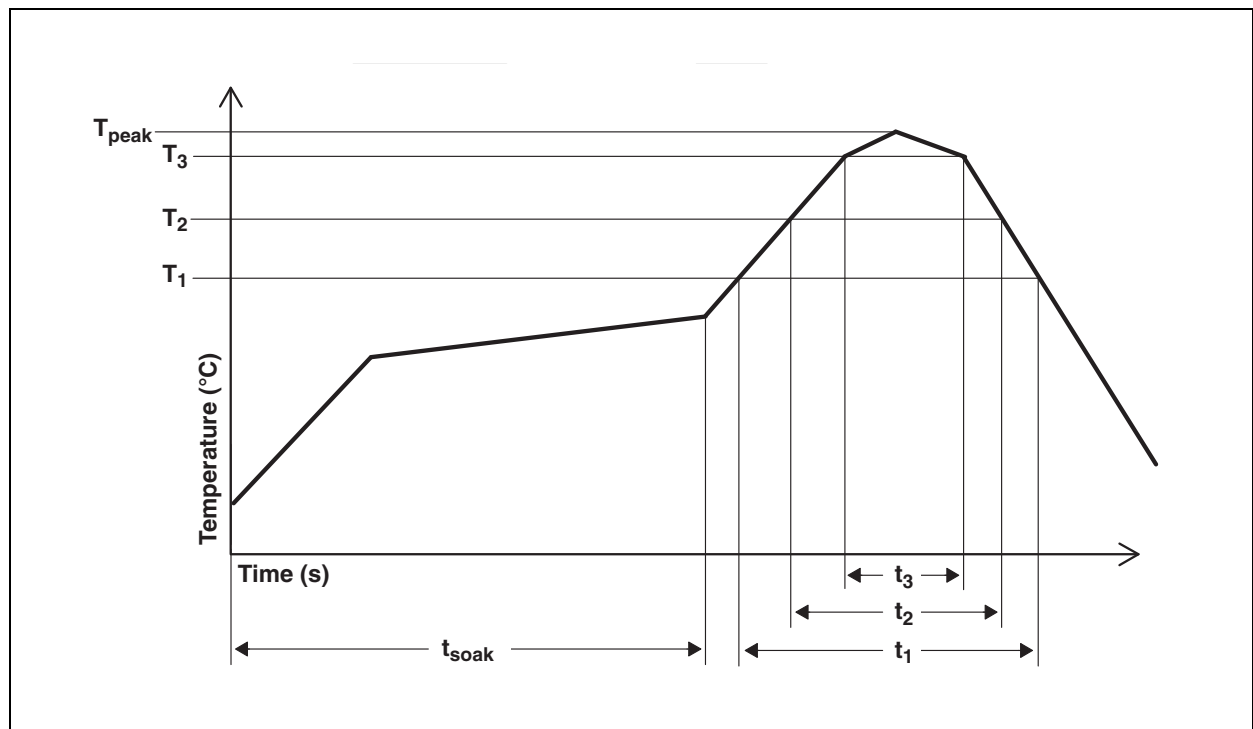

Note(s):

1. Not to scale – for reference only.

Storage Information

Moisture Sensitivity

Optical characteristics of the device can be adversely affected during the soldering process by the release and vaporization of moisture that has been previously absorbed into the package. To ensure the package contains the smallest amount of absorbed moisture possible, each device is dry-baked prior to being packed for shipping.

Devices are packed in a sealed aluminized envelope called a moisture barrier bag with silica gel to protect them from ambient moisture during shipping, handling, and storage before use.

The CL package has been assigned a moisture sensitivity level of MSL 5a and the devices should be stored under the following conditions:

- Temperature Range: 5°C to 50°C
- Relative Humidity: 60% maximum
- Total Time: 6 months from the date code on the aluminized envelope—if unopened
- Opened Time: 24 hours or fewer

Rebaking will be required if the devices have been stored unopened for more than 6 months or if the aluminized envelope has been open for more than 24 hours. If rebaking is required, it should be done at 60°C for 24 hours.

Ordering & Contact Information

Figure 26:
Ordering Information

Ordering Code	Type	Package Designator	Delivery Form	Delivery Quantity
TSL3301CL	102 x 1 Array	CL	Tape & Reel	1000 pcs/reel

Buy our products or get free samples online at:

www.ams.com/ICdirect

Technical Support is available at:

www.ams.com/Technical-Support

Provide feedback about this document at:

www.ams.com/Document-Feedback

For further information and requests, e-mail us at:

ams_sales@ams.com

For sales offices, distributors and representatives, please visit:

www.ams.com/contact

Headquarters

ams AG

Tobelbader Strasse 30

8141 Premstaetten

Austria, Europe

Tel: +43 (0) 3136 500 0

Website: www.ams.com

RoHS Compliant & ams Green Statement

RoHS: The term RoHS compliant means that ams AG products fully comply with current RoHS directives. Our semiconductor products do not contain any chemicals for all 6 substance categories, including the requirement that lead not exceed 0.1% by weight in homogeneous materials. Where designed to be soldered at high temperatures, RoHS compliant products are suitable for use in specified lead-free processes.

ams Green (RoHS compliant and no Sb/Br): ams Green defines that in addition to RoHS compliance, our products are free of Bromine (Br) and Antimony (Sb) based flame retardants (Br or Sb do not exceed 0.1% by weight in homogeneous material).

Important Information: The information provided in this statement represents ams AG knowledge and belief as of the date that it is provided. ams AG bases its knowledge and belief on information provided by third parties, and makes no representation or warranty as to the accuracy of such information. Efforts are underway to better integrate information from third parties. ams AG has taken and continues to take reasonable steps to provide representative and accurate information but may not have conducted destructive testing or chemical analysis on incoming materials and chemicals. ams AG and ams AG suppliers consider certain information to be proprietary, and thus CAS numbers and other limited information may not be available for release.

Copyrights & Disclaimer

Copyright ams AG, Tobelbader Strasse 30, 8141 Premstaetten, Austria-Europe. Trademarks Registered. All rights reserved. The material herein may not be reproduced, adapted, merged, translated, stored, or used without the prior written consent of the copyright owner.

Devices sold by ams AG are covered by the warranty and patent indemnification provisions appearing in its General Terms of Trade. ams AG makes no warranty, express, statutory, implied, or by description regarding the information set forth herein. ams AG reserves the right to change specifications and prices at any time and without notice. Therefore, prior to designing this product into a system, it is necessary to check with ams AG for current information. This product is intended for use in commercial applications. Applications requiring extended temperature range, unusual environmental requirements, or high reliability applications, such as military, medical life-support or life-sustaining equipment are specifically not recommended without additional processing by ams AG for each application. This product is provided by ams AG "AS IS" and any express or implied warranties, including, but not limited to the implied warranties of merchantability and fitness for a particular purpose are disclaimed.

ams AG shall not be liable to recipient or any third party for any damages, including but not limited to personal injury, property damage, loss of profits, loss of use, interruption of business or indirect, special, incidental or consequential damages, of any kind, in connection with or arising out of the furnishing, performance or use of the technical data herein. No obligation or liability to recipient or any third party shall arise or flow out of ams AG rendering of technical or other services.

Document Status

Document Status	Product Status	Definition
Product Preview	Pre-Development	Information in this datasheet is based on product ideas in the planning phase of development. All specifications are design goals without any warranty and are subject to change without notice
Preliminary Datasheet	Pre-Production	Information in this datasheet is based on products in the design, validation or qualification phase of development. The performance and parameters shown in this document are preliminary without any warranty and are subject to change without notice
Datasheet	Production	Information in this datasheet is based on products in ramp-up to full production or full production which conform to specifications in accordance with the terms of ams AG standard warranty as given in the General Terms of Trade
Datasheet (discontinued)	Discontinued	Information in this datasheet is based on products which conform to specifications in accordance with the terms of ams AG standard warranty as given in the General Terms of Trade, but these products have been superseded and should not be used for new designs

Revision Information

Changes from 1-00 (2016-Jun-28) to current revision 1-01 (2017-Aug-30)	Page
Updated Figure 10 and removed notes under it	14

Note(s):

1. Page and figure numbers for the previous version may differ from page and figure numbers in the current revision.
2. Correction of typographical errors is not explicitly mentioned.

Content Guide

1	General Description
1	Key Benefits & Features
2	Functional Block Diagram
3	Pin Assignments
4	Detailed Description
6	Serial Interface
7	Register Address Map
8	Command Description
9	Programming Information
9	Reset Commands
9	Pixel Action Commands
10	Register Commands
12	Operation
12	Initialization Sequence
12	Sleep Mode
13	Imaging
14	Absolute Maximum Ratings
15	Electrical Characteristics
18	Typical Operation Characteristics
20	Application Information
20	Software
20	Normal Sequence
21	Hardware
21	PCB Pad Layout
22	Package Information
24	Soldering Information
25	Storage Information
25	Moisture Sensitivity
26	Ordering & Contact Information
27	RoHS Compliant & ams Green Statement
28	Copyrights & Disclaimer
29	Document Status
30	Revision Information