

Modbus RTU (EIA-485) Interface for Daikin air conditioners

Compatible with Domestic line models

USER MANUAL

Issue date: 12/2017 r2.3 ENGLISH



Important User Information

Disclaimer

The information in this document is for informational purposes only. Please inform HMS Industrial Networks of any inaccuracies or omissions found in this document. HMS Industrial Networks disclaims any responsibility or liability for any errors that may appear in this document.

HMS Industrial Networks reserves the right to modify its products in line with its policy of continuous product development. The information in this document shall therefore not be construed as a commitment on the part of HMS Industrial Networks and is subject to change without notice. HMS Industrial Networks makes no commitment to update or keep current the information in this document.

The data, examples and illustrations found in this document are included for illustrative purposes and are only intended to help improve understanding of the functionality and handling of the product. In view of the wide range of possible applications of the product, and because of the many variables and requirements associated with any particular implementation, HMS Industrial Networks cannot assume responsibility or liability for actual use based on the data, examples or illustrations included in this document nor for any damages incurred during installation of the product. Those responsible for the use of the product must acquire sufficient knowledge in order to ensure that the product is used correctly in their specific application and that the application meets all performance and safety requirements including any applicable laws, regulations, codes and standards. Further, HMS Industrial Networks will under no circumstances assume liability or responsibility for any problems that may arise as a result from the use of undocumented features or functional side effects found outside the documented scope of the product. The effects caused by any direct or indirect use of such aspects of the product are undefined and may include e.g. compatibility issues and stability issues.

Modbus RTU (EIA-485) Interface for Daikin air conditioners.
Compatible with Domestic line models.

ORDER CODE	LEGACY ORDER CODE
INMBSDAI001I000	DK-AC-MBS-1

INDEX

1. Presentation	5
2. Connection	6
2.1 Connect to the AC indoor unit	6
2.2 Connection to the EIA-485 bus.....	6
3. Quick Start Guide	7
4. Modbus Interface Specification	8
4.1 Modbus physical layer	8
4.2 Modbus Registers	8
4.2.1 Control and status registers	8
4.2.2 Configuration Registers	10
4.2.3 Considerations on Temperature Registers	10
4.3 DIP-switch Configuration Interface	13
4.4 Implemented Functions.....	16
4.5 Device LED indicator	16
4.6 EIA-485 bus. Termination resistors and Fail-Safe Biasing mechanism.....	16
5. Mechanical and electrical features.....	17
6. List of supported AC Unit Types	18
7. Error Codes	19

1. Presentation



The INMBSDAI001I000 interface allows a complete and natural integration of **Daikin** air conditioners into Modbus RTU (EIA-485) networks.

Compatible with Domestic line models.

Reduced dimensions. 93 x 53 x 58 mm
3.7" x 2.1" x 2.3"

- Quick and easy installation.
Mountable on DIN rail, wall, or even inside the indoor unit on some models of AC.
- External power not required.
- Direct connection to Modbus RTU (EIA-485) networks. Up to 63 INMBSDAI001I000 devices can be connected on the same network.
INMBSDAI001I000 is a Modbus slave device.
- Direct connection to the AC indoor unit. Up to 1 AC indoor units can be connected to INMBSDAI001I000. *The cable for this connection is also supplied.*
- Configuration from both on-board DIP-switches and Modbus RTU.
- Total Control and Supervision.
- Real states of the AC unit's internal variables.
- Allows simultaneous use of the AC's remote controls and Modbus RTU.

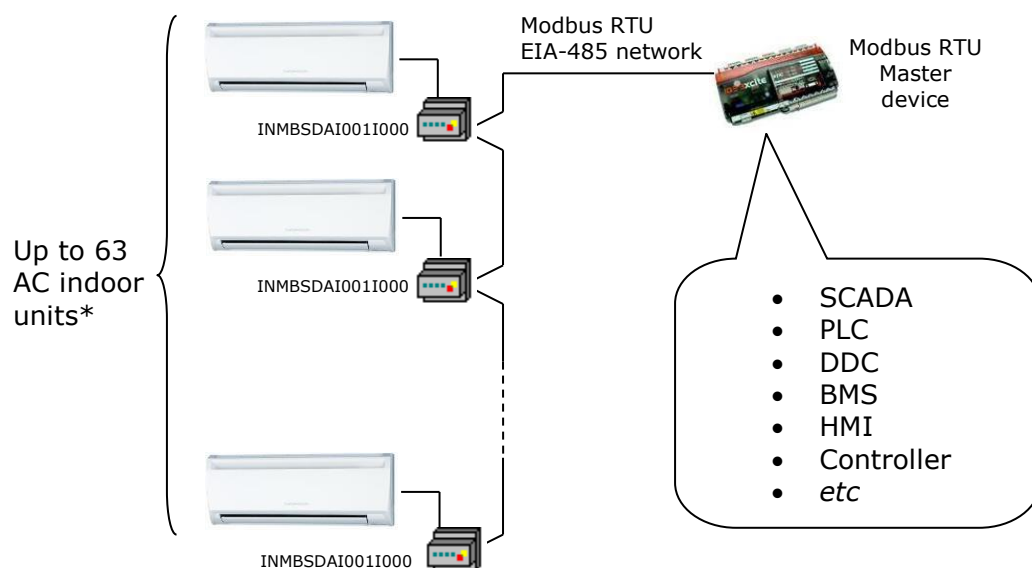

* Up to 63 Intesis devices can be installed in the same Modbus RTU bus. However, depending on the configured speed, the installation of Modbus Repeaters may be required

2. Connection

The interface comes with a specific cable and connectors to establish direct connection to the AC indoor unit. It comes as well with a plug-in terminal block of 2 poles to establish direct connection with the Modbus RTU EIA-485 network.

2.1 Connect to the AC indoor unit

To connect the INMBSDAI001I000 interface with the AC indoor unit you must follow these steps:

Disconnect Mains Power from the AC unit. Open the front cover of the indoor unit to have access to the electronic circuit. Once you arrive at the electronic circuit, locate the socket connector marked as **S21**.

Take the cable that comes with the interface, insert one of its connectors (the one installed in the shortest uncovered part) into the socket of the INMBSDAI001I000, and the other connector (the one installed in the largest uncovered part) to the socket **S21** of the AC unit's electronic circuit. Remember that the INMBSDAI001I000 must also be connected to the Modbus RTU EIA-485 network. Close the AC indoor unit's front cover again to finish the connection.

Do not modify the length of the cable supplied with the interface, it may affect the correct interface's operation.

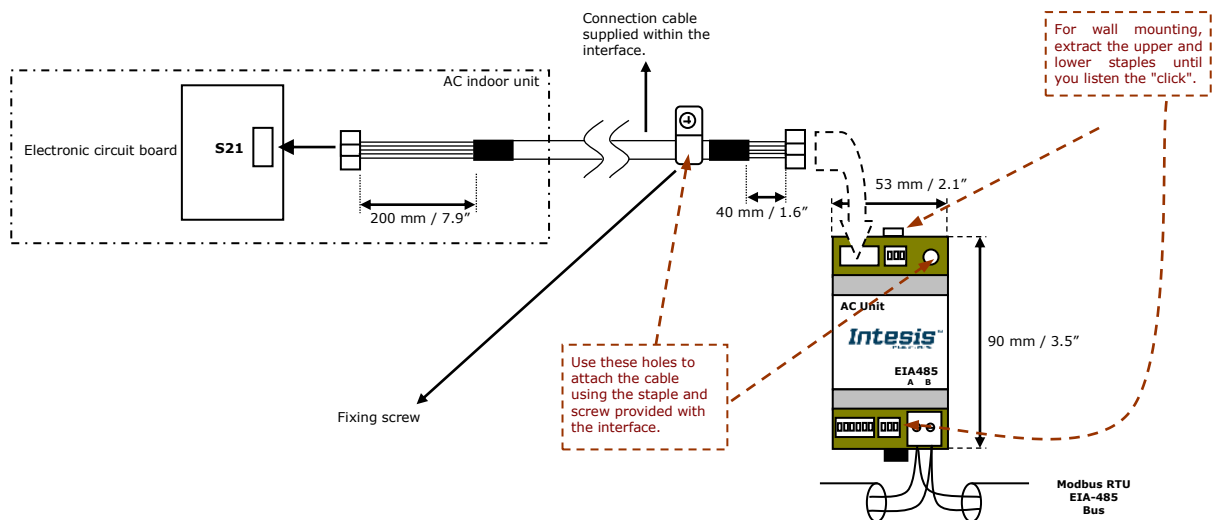

2.2 Connection to the EIA-485 bus

Connect the EIA-485 bus wires to the plug-in terminal block (the one of two poles) of INMBSDAI001I000 and keep the polarity on this connection (A+ and B-). Make sure that the maximum distance to the bus is 1,200 meters (3,937 ft). The loop or star typologies are not allowed in the case of the EIA-485. A terminator resistor of 120Ω must be present at each end of the bus to avoid signal reflections. The bus needs a fail-safe biasing mechanism (see section 4.6 for more details).

3. Quick Start Guide

1. Disconnect the air conditioning from the Mains Power.
2. Attach the interface next to the AC indoor unit (wall mounting) following the instructions of the diagram below or install it inside the AC indoor unit (respect the safety instructions given above).
3. Connect the connection cable included with the interface between the interface and the AC indoor unit following the instructions of the diagram.
4. Connect the EIA-485 bus to the connector *EIA485* of the interface.
5. Close the AC indoor unit.
6. Check the DIP-Switch configuration of the Intesis interface and make sure it matches the current installation's parameters (see section 4.3).

By default, the interface is set to:

- Modbus Slave Address → 1
- Modbus baud rate → 9600 bps



These parameters can be modified from SW4 and SW3 DIP-Switches.

All other switch positions are set at low level (Off position ) by default.

NOTE: All changes on the DIP-Switch configuration require a system power cycle to be applied.

7. Connect the AC system to Mains Power.

IMPORTANT: The Intesis interface requires to be connected to the AC unit (powered) to start communicating.

4. Modbus Interface Specification

4.1 Modbus physical layer

INMBSDAI001I000 implements a Modbus RTU (Slave) interface, to be connected to an EIA-485 line. It performs an 8N2 communication (8 data bits, no parity and 2 stop bit) with several available baud rates (2400 bps, 4800 bps, 9600 bps -default-, 19200 bps, 38400 bps, 57600 bps, 76800 bps and 115200 bps). It also supports 8N1 communication (8 data bits, no parity and 1 stop bit).

4.2 Modbus Registers

All registers are type "16-bit unsigned Holding Register" and they use the standard *ModBus big endian* notation.

4.2.1 Control and status registers

Register Address (protocol address)	Register Address (PLC address)	R/W	Description
0	1	R/W	AC unit On/Off <ul style="list-style-type: none"> ▪ 0: Off ▪ 1: On
1	2	R/W	AC unit Mode ¹ <ul style="list-style-type: none"> ▪ 0: Auto ▪ 1: Heat ▪ 2: Dry ▪ 3: Fan ▪ 4: Cool
2	3	R/W	AC unit Fan Speed ¹ <ul style="list-style-type: none"> ▪ 0: Auto ▪ 1: Low ▪ 2: Mid-1 ▪ 3: Mid-2 ▪ 4: Mid-3 ▪ 5: High
3	4	R/W	AC unit Up/Down Vane Position ¹ <ul style="list-style-type: none"> ▪ 0: Off (Default) ▪ 10: Swing
4	5	R/W	AC unit Temperature setpoint ^{1,2,3} <ul style="list-style-type: none"> ▪ -32678 (Initialization value) <p>COOL</p> <ul style="list-style-type: none"> ▪ 18..32 °C (°C/x10°C) ▪ 64..92 °F <p>HEAT</p> <ul style="list-style-type: none"> ▪ 16..30 °C (°C/x10°C) ▪ 61..88 °F <p>AUTO</p> <ul style="list-style-type: none"> ▪ 18..30 °C (°C/x10°C) ▪ 64..88 °F

¹ Available values will depend on the AC unit mode. Check the AC unit model functions in its user manual to know the possible values for this register.

² Magnitude for this register can be adjusted to Celsius x 1°C, Celsius x 10°C (default) or Fahrenheit. See section 4.2.3 for more information

³ It is not possible turn to x10 the value shown in Fahrenheit.

Register Address (protocol address)	Register Address (PLC address)	R/W	Description
5	6	R	AC unit Temperature reference ^{1,2,3} <ul style="list-style-type: none"> -32678 (Initialization value) 10..38 °C (°C/x10°C) 50..100 °F
6	7	R/W	Window Contact <ul style="list-style-type: none"> 0: Closed (Default Value) 1: Open
7	8	R/W	INMBSDAI001I000 Disablement ⁴ <ul style="list-style-type: none"> 0: INMBSDAI001I000 enabled (Default Value) 1: INMBSDAI001I000 disabled
8	9	R/W	AC Remote Control Disablement ⁴ <ul style="list-style-type: none"> 0: Remote Control enabled (Default) 1: Remote Control disabled
9	10	R/W	AC unit Operation Time ⁴ <ul style="list-style-type: none"> 0..65535 (hours). Counts the time the AC unit is in "On" state.
10	11	R	AC unit Alarm Status <ul style="list-style-type: none"> 0: No alarm condition 1: Alarm condition
11	12	R	Error Code ⁵ <ul style="list-style-type: none"> 0: No error present 65535 (-1 if it is read as signed value): Error in the communication of INMBSDAI001I000 with the AC unit Any other error present, see the table at the end of this document.
22	23	R/W	Indoor unit ambient temperature from external sensor (at Modbus side) ^{1,2,3,6} <ul style="list-style-type: none"> -32768: (Initialization value). No temperature is being provided from an external sensor. Any other: (°C/x10°C/°F)
23	24	R	AC Real temperature setpoint ^{1,2,3,6} <ul style="list-style-type: none"> -32678 (Initialization value) COOL <ul style="list-style-type: none"> 18..32 °C (°C/x10°C) 64..92 °F HEAT <ul style="list-style-type: none"> 16..30 °C (°C/x10°C) 61..88 °F AUTO <ul style="list-style-type: none"> 18..30 °C (°C/x10°C) 64..88 °F
26	27	R/W	AC unit Left/Right Vane Position ¹ <ul style="list-style-type: none"> 0: Auto (Default Value) 10: Swing
28	29	R/W	AC Humidification Value ¹ <ul style="list-style-type: none"> 0: Off 1: Low Humidification 2: Medium Humidification 3: High Humidification

⁴ This value is stored in non-volatile memory

⁵ See section 7 for possible error codes and their explanation

⁶ See section 4.2.3 for more information

			<ul style="list-style-type: none"> 4: Continuous
97	98	R/W	Block Periodic Sendings ^{4,7,8} <ul style="list-style-type: none"> 0: Non-blocked (Default value) 1: Blocked

4.2.2 Configuration Registers

Register Address (protocol address)	Register Address (PLC address)	R/W	Description
13	14	R/W	"Open Window" switch-off timeout ⁹ <ul style="list-style-type: none"> 0..30 (minutes) Factory setting: 30 (minutes)
14	15	R	Modbus RTU Baud rate <ul style="list-style-type: none"> 2400bps 4800bps 9600bps (Default) 19200bps 38400bps 57600bps 76800bps 115200bps
15	16	R	Device's Modbus Slave address <ul style="list-style-type: none"> 1..63
21	22	R	Max number of fan speeds <ul style="list-style-type: none"> Value is always 5
49	50	R	Device ID: 0x0701
50	51	R	Software version

4.2.3 Considerations on Temperature Registers

- AC unit temperature setpoint (R/W)**
 (register 4 – in Protocol address / register 5 – in PLC address):
 This is the adjustable temperature setpoint value that must be required by the User. This register can be read (Modbus function 3 or 4) or written (Modbus functions 6 or 16). A Remote Controller connected to the Daikin indoor unit will report the same temperature setpoint value as this register. This will apply when no AC unit's external reference temperature is provided from INMBSDAI001I000 (see details for register 22/23 below).
- AC unit temperature reference (R)**
 (register 5 – in Protocol address / register 6 – in PLC address):

⁷ If the register is configured as "0:Non-blocked", all commands received from Modbus will be sent to the AC system. If "1:Blocked", commands from Modbus will only be sent to the AC system if they differ from the previous value (values sent on change).

⁸ The register applies to firmware version 1.5 onwards

⁹ Once window contact is open, a count-down to switch off the AC Unit will start from this configured value.

This register reports the temperature that is currently used by the Daikin indoor unit as the reference of its own control loop. Depending on the configuration of the indoor unit, this value can be the temperature reported by the sensor on the return path of the Daikin indoor unit or the sensor of its Remote Controller. It is a read-only register (Modbus functions 3 or 4).

- **AC unit external temperature reference (Modbus) (R/W)**

(register 22 – in Protocol address / register 23 – in PLC address):

This register allows us to provide an external temperature's sensor from the Modbus side. Daikin indoor unit does not allow, on devices like INMBSDAI001I000, to provide directly a temperature to be used as a reference of the control loop of the AC indoor unit. In order to overcome this limitation and enable the usage of an external temperature sensor (e.g. from Modbus side), INMBSDAI001I000 applies the following mechanism (only if "external temperature's reference" is being used):

- After a couple of values have been entered in the "AC unit external temperature's reference" (register 22/23) and the "AC unit temperature set point" (register 4/5), INMBSDAI001I000 calculates the corresponding temperature's demand (e.g., if a "temperature setpoint (register 4/5)" of **22°C**, and an "external temperature reference (register 22/23)" of **20°C** are entered, INMBSDAI001I000 will assume that the user is demanding a **+2°C** increase in temperature).
- By knowing at any time, the ambient temperature currently used by the indoor unit to control its own operation (register 5/6), INMBSDAI001I000 can calculate the required temperature setpoint needed to apply the decrease/increase on the real temperature and reach the temperature chosen by the user (following the example above, if INMBSDAI001I000 reads an "ambient temperature" (register 5/6) of **24°C** in the indoor unit, it will apply a final setpoint of **24°C + 2°C = 26°C**).
- At this moment, each time that INMBSDAI001I000 detects a change on the ambient temperature reported by the indoor unit (register 5/6), it will also change the required setpoint, in order to keep the temperature required by the User at any time. If we follow the last example, when INMBSDAI001I000 receives a new temperature's value coming from the indoor unit of **25°C**, INMBSDAI001I000 will automatically adjust the temperature setpoint required of the AC indoor unit to **25°C + 2°C = 27°C**).
- In general, INMBSDAI001I000 is constantly applying the "Virtual Temperature" formula:

$$S_{AC} = S_u - (T_u - T_{AC})$$

Where:

S_{AC} - setpoint value currently applied to the indoor unit

S_u - setpoint value written at Modbus side (register 4/5)

T_u - external temperature reference written at Modbus side (register 22/23)

T_{AC} - ambient temperature that the indoor unit is using as the reference of its own control loop (register 5/6)

When INMBSDAI001I000 detects a change in any of the values of $\{ S_u, T_u, T_{AC} \}$, it will send the new setpoint (S_{AC}) to the indoor unit.

- After the startup, the value for "external temperature's reference" (register 22/23) has a value -32768 (0x8000). This value means that no external temperature reference is being provided through INMBSDAI001I000. In this

scenario, the setpoint value shown or written in register 4/5 will always be the same as the current setpoint value of the indoor unit.

- Notice that, the use of the "external temperature reference" (register 22/23) (e.g., writing a value different from -32768 / 0x8000 in it) has the following relevant consequences:
 - The mechanism of "Virtual Temperature" is applied. The temperature setpoint's value shown by the Remote Controller or other Control System from Daikin connected to the indoor unit may show a different value from the value shown in register 4/5.
 - The User is not be able to change the setpoint using any Remote Controller from Daikin, as setpoint of the indoor unit becomes exclusively controlled by the "Virtual Temperature" mechanism.
- **AC Real temperature setpoint (R)**

(register 23 – In Protocol address / register 24 – in PLC address):

As it has been detailed on the previous point, the real temperature setpoint in the indoor unit and the temperature setpoint requested from INMBSDAI001I000 might differ (when a value in register 22/23 – "external temperature reference" is entered). This register always informs about the current temperature setpoint which is being used by the indoor unit – it also includes the temperature setpoint that will be shown by an additional remote controller from Daikin connected to the indoor unit, if it is present on the system.

Moreover, notice that temperature's values of all these three registers are expressed according to the temperature's format configured through its onboard DIP-Switches (See 4.3). The following formats are possible:

- **Celsius value:** Value in Modbus register is the temperature value in Celsius (i.e. a value "22" in the Modbus register must be interpreted as 22°C).
- **Decicelsius value:** Value in Modbus register is the temperature value in decicelsius (i.e. a value "220" in the Modbus register must be interpreted as 22.0°C).
- **Fahrenheit value:** Value in Modbus register is the temperature value in Fahrenheit (i.e. a value "72" in the Modbus register must be interpreted as 72°F (~22°C)).

4.3 DIP-switch Configuration Interface

All the configuration values on INMBSDAI001I000 can be written and read from Modbus interface. Otherwise, some of them can also be setup from its on-board DIP-switch interface. The device has DIP-switches SW1*, SW3 and SW4 on the following locations:

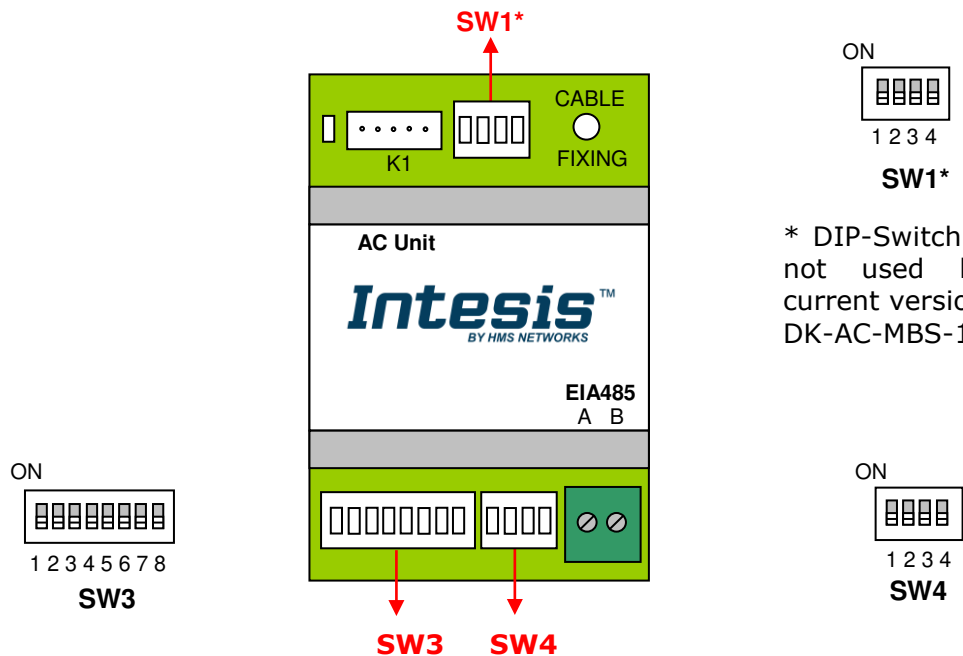

The following tables apply to the interface's configuration through DIP-switches:

SW4 –Degrees/Decidegrees (x10), temperature magnitude (°C/°F) and EIA-485 termination resistor.

SW4-P1..2-4	Description
	Temperature values in Modbus register are represented in degrees (x1) (Default value)
	Temperature values in Modbus register are represented in decidegrees (x10)
	Temperature values in Modbus register are represented in Celsius degrees (Default value)
	Temperature values in Modbus register are represented in Fahrenheit degrees
	EIA-485 bus without termination resistor (Default value)
	Internal termination resistor of 120Ω connected to EIA-485 bus

Table 4.1 SW4: Temperature and termination resistor configuration

SW3/SW4 – Baud rate configuration















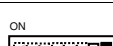

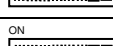
SW3-P7..8	SW4-P3	Description
ON 	ON 	2400bps
ON 	ON 	4800bps
ON 	ON 	9600bps (Default value)
ON 	ON 	19200bps
ON 	ON 	38400bps
ON 	ON 	57600bps
ON 	ON 	76800bps
ON 	ON 	115200bps

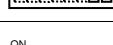
Table 4.2 SW3-SW4: Modbus baud rate

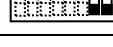
SW3 – Modbus Slave address

Add	SW3-P1..6	Add	SW3-P1..6	Add	SW3-P1..6	Add	SW3-P1..6	Add	SW3-P1..6
0		13		26		39		52	
1		14		27		40		53	
2		15		28		41		54	
3		16		29		42		55	
4		17		30		43		56	
5		18		31		44		57	
6		19		32		45		58	
7		20		33		46		59	
8		21		34		47		60	
9		22		35		48		61	
10		23		36		49		62	
11		24		37		50		63	
12		25		38		51			

Table 4.3 SW3: Modbus Slave address

4.4 Implemented Functions

INMBSDAI001I000 implements the following standard Modbus functions:

- 3: Read Holding Registers
- 4: Read Input Registers
- 6: Write Single Register
- 16: Write Multiple Registers (Despite this function is allowed, the interface does not allow to write operations on more than 1 register with the same request, this means that length field should always be 1 when this function is being used in case of writing)

4.5 Device LED indicator

The device includes a LED indicator to show all the possible operational states. In the following table there are written the indicators which can be performed and its meaning.

Device status	LED indication	ON / OFF Period	Description
On power-up	LED pulse	ON for 5 seconds / OFF after	Device reset / power-up
During normal operation	LED flashing	200ms ON / 2s OFF	Device correctly configured and working
During normal operation	LED OFF	OFF continuously	No Modbus Slave address configured
During normal operation	LED blinking	200ms ON / 200ms OFF	Communication Error with the AC unit

4.6 EIA-485 bus. Termination resistors and Fail-Safe Biasing mechanism

EIA-485 bus requires a 120Ω terminator resistor at each end of the bus to avoid signal reflections.

In order to prevent fail status detections by the receivers, which are "listening" the bus, when all the transmitters' outputs are in three-state (high impedance), it is also required a fail-safe biasing mechanism. This mechanism provides a safe status (a correct voltage level) in the bus when all the transmitters' outputs are in three-state.

The INMBSDAI001I000 device includes an on-board terminator resistor of 120Ω that can be connected to the EIA-485 bus by using DIP-switch SW4.

Some Modbus RTU EIA-485 Master devices can provide also internal 120Ω terminator resistor and/or fail-safe biasing. Check the technical documentation of the Master device connected to the EIA-485 network in each case.

5. Mechanical and electrical features

Enclosure	Plastic, type PC (UL 94 V-0) Net dimensions (dxwxh): 93 x 53 x 58 mm / 3.7" x 2.1" x 2.3" Color: Light Grey. RAL 7035	Operation Temperature	0°C to +60°C
Weight	85 g.	Stock Temperature	-20°C to +85°C
Mounting	Wall DIN rail EN60715 TH35.	Operational Humidity	<95% RH, non-condensing
Terminal Wiring (for low-voltage signals)	For terminal: solid wires or stranded wires (twisted or with ferrule) 1 core: 0.5mm ² ... 2.5mm ² 2 cores: 0.5mm ² ... 1.5mm ² 3 cores: not permitted	Stock Humidity	<95% RH, non-condensing
Modbus RTU port	1 x Serial EIA485 Plug-in screw terminal block (2 poles) A, B Compatible with Modbus RTU EIA-485 networks	Isolation voltage	1500 VDC
AC unit port	1 x Specific connector Specific cable included	Isolation resistance	1000 MΩ
Switch 1 (SW1)	1 x DIP-Switch	Protection	IP20 (IEC60529)
Switch 3 (SW3)	1 x DIP-Switch for Modbus RTU settings	LED indicators	1 x Onboard LED - Operational status
Switch 4 (SW4)	1 x DIP-Switch for extra functions		

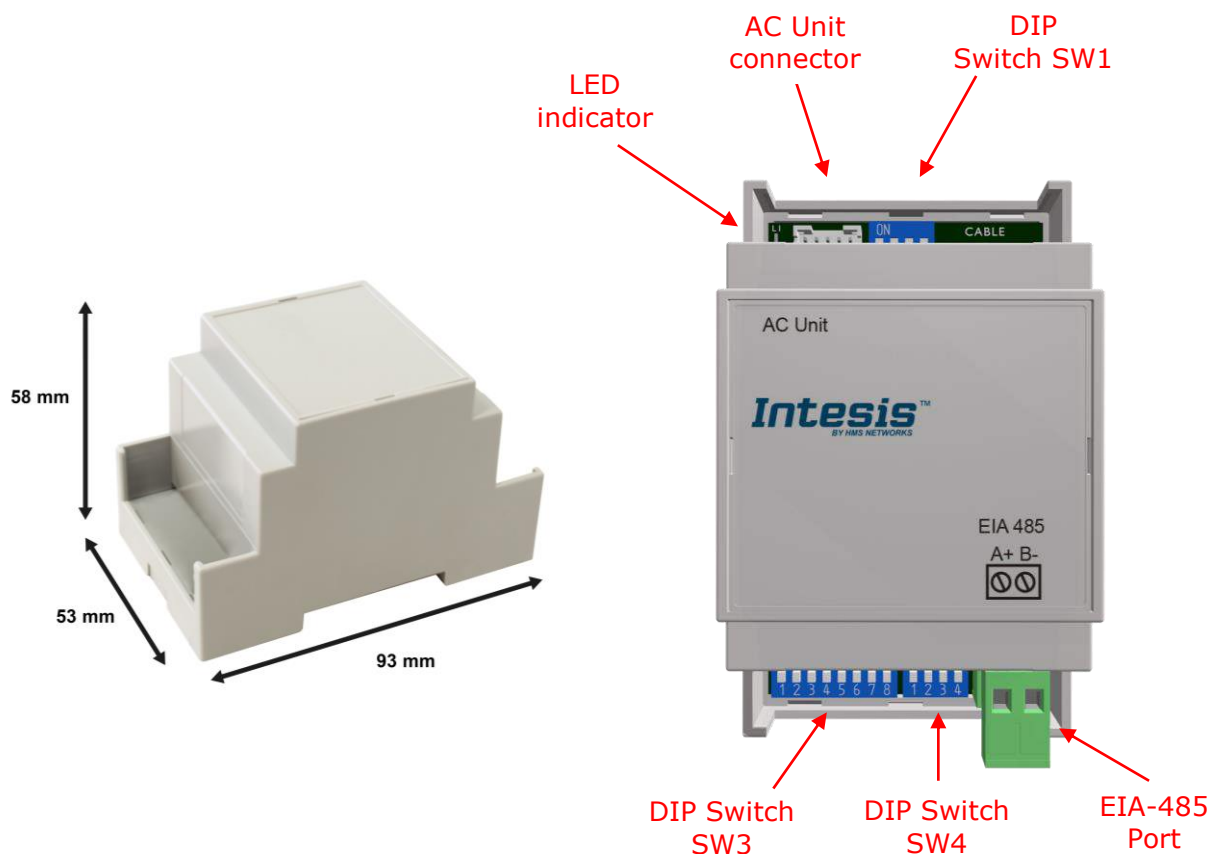

6. List of supported AC Unit Types

A list of Daikin indoor unit model's references compatible with INMBSDAI001I000 and its available features can be found in:

https://www.intesis.com/docs/compatibilities/inxxxdai001xx00_compatibility

7. Error Codes

Error Code	Error in Remote Controller	Error category	Error Description
0	N/A	INMBSDAI001I000	No active error
17	A0	Indoor Unit	External protection devices activated
18	A1		Indoor unit PCB assembly failure
19	A2		Interlock error for fan
20	A3		Drain level system error
21	A4		Temperature of heat exchanger (1) error
22	A5		Temperature of heat exchanger (2) error
23	A6		Fan motor locked, overload, over current
24	A7		Swing flap motor error
25	A8		Overcurrent of AC input
26	A9		Electronic expansion valve drive error
27	AA		Heater overheat
28	AH		Dust collector error / No-maintenance filter error
30	AJ		Capacity setting error (indoor)
31	AE		Shortage of water supply
32	AF		Malfunctions of a humidifier system (water leaking)
33	C0		Malfunctions in a sensor system
36	C3		Sensor system of drain water error
37	C4		Heat exchanger (1) (Liquid pipe) thermistor system error
38	C5		Heat exchanger (1) (Gas pipe) thermistor system error
39	C6		Sensor system error of fan motor locked, overload
40	C7		Sensor system of swing flag motor error
41	C8		Sensor system of over-current of AC input
42	C9		Suction air thermistor error
43	CA		Discharge air thermistor system error
44	CH		Contamination sensor error
45	CC		Humidity sensor error
46	CJ		Remote control thermistor error
47	CE		Radiation sensor error
48	CF		High pressure switch sensor
49	E0		Outdoor Unit
50	E1	Outdoor unit PCB assembly failure	
52	E3	High pressure switch (HPS) activated	
53	E4	Low pressure switch (LPS) activated	
54	E5	Overload of inverter compressor motor	
55	E6	Over current of STD compressor motor	
56	E7	Overload of fan motor / Over current of fan motor	
57	E8	Over current of AC input	
58	E9	Electronic expansion valve drive error	
59	EA	Four-way valve error	
60	EH	Pump motor over current	
61	EC	Water temperature abnormal	
62	EJ	(Site installed) Protection device activated	
63	EE	Malfunctions in a drain water	
64	EF	Ice thermal storage unit error	
65	H0	Malfunctions in a sensor system	
66	H1	Air temperature thermistor error	
67	H2	Sensor system of power supply error	
68	H3	High Pressure switch is faulty	
69	H4	Low pressure switch is faulty	
70	H5	Compressor motor overload sensor is abnormal	
71	H6	Compressor motor over current sensor is abnormal	
72	H7	Overload or over current sensor of fan motor is abnormal	

73	H8		Sensor system of over-current of AC input
74	H9		Outdoor air thermistor system error
75	HA		Discharge air thermistor system error
76	HH		Pump motor sensor system of over current is abnormal
77	HC		Water temperature sensor system error
79	HE		Sensor system of drain water is abnormal
80	HF		Ice thermal storage unit error (alarm)
81	F0		No.1 and No.2 common protection device operates.
82	F1		No.1 protection device operates.
83	F2		No.2 protection device operates
84	F3		Discharge pipe temperature is abnormal
87	F6		Temperature of heat exchanger(1) abnormal
91	FA		Discharge pressure abnormal
92	FH		Oil temperature is abnormally high
93	FC		Suction pressure abnormal
95	FE		Oil pressure abnormal
96	FF		Oil level abnormal
97	J0		Sensor system error of refrigerant temperature
98	J1		Pressure sensor error
99	J2		Current sensor error
100	J3		Discharge pipe thermistor system error
101	J4		Low pressure equivalent saturated temperature sensor system error
102	J5		Suction pipe thermistor system error
103	J6		Heat exchanger(1) thermistor system error
104	J7		Heat exchanger(2) thermistor system error
105	J8		Oil equalizer pipe or liquid pipe thermistor system error
106	J9		Double tube heat exchanger outlet or gas pipe thermistor system error
107	JA		Discharge pipe pressure sensor error
108	JH		Oil temperature sensor error
109	JC		Suction pipe pressure sensor error
111	JE		Oil pressure sensor error
112	JF		Oil level sensor error
113	L0		Inverter system error
116	L3		Temperature rise in a switch box
117	L4		Radiation fin (power transistor) temperature is too high
118	L5		Compressor motor grounded or short circuit, inverter PCB fault
119	L6		Compressor motor grounded or short circuit, inverter PCB fault
120	L7		Over current of all inputs
121	L8		Compressor over current, compressor motor wire cut
122	L9		Stall prevention error (start-up error) Compressor locked, etc.
123	LA		Power transistor error
125	LC		Communication error between inverter and outdoor control unit
129	P0		Shortage of refrigerant (thermal storage unit)
130	P1		Power voltage imbalance, open phase
132	P3		Sensor error of temperature rise in a switch box
133	P4		Radiation fin temperature sensor error
134	SW4		DC current sensor system error
135	SW1		AC or DC output current sensor system error
136	SW3		Total input current sensor error
142	PJ		Capacity setting error (outdoor)
145	U0	System	Low pressure drop due to insufficient refrigerant or electronic

			expansion valve error, etc.
146	U1		Reverse phase, Open phase
147	U2		Power voltage failure / Instantaneous power failure
148	U3		Failure to carry out check operation, transmission error
149	U4		Communication error between indoor unit and outdoor unit, communication error between outdoor unit and BS unit
150	U5		Communication error between remote control and indoor unit / Remote control board failure or setting error for remote control
151	U6		Communication error between indoor units
152	U7		Communication error between outdoor units / Communication error between outdoor unit and ice thermal storage unit
153	U8		Communication error between main and sub remote controllers (sub remote control error) / Combination error of other indoor unit / remote control in the same system (model)
154	U9		Communication error between other indoor unit and outdoor unit in the same system / Communication error between other BS unit and indoor/outdoor unit
155	UA		Combination error of indoor/BS/outdoor unit (model, quantity, etc.), setting error of spare parts PCB when replaced
156	UH		Improper connection of transmission wiring between outdoor and outdoor unit outside control adaptor
157	UC		Centralized address duplicated
158	UJ		Attached equipment transmission error
159	UE		Communication error between indoor unit and centralized control device
160	UF		Failure to carry out check operation Indoor-outdoor, outdoor-outdoor communication error, etc.
209	60	Others	All system error
210	61		PC board error
211	62		Ozone density abnormal
212	63		Contamination sensor error
213	64		Indoor air thermistor system error
214	65		Outdoor air thermistor system error
217	68		HVU error (Venti-air dust-collecting unit)
219	6A		Dumper system error
220	6H		Door switch error
221	6C		Replace the humidity element
222	6J		Replace the high efficiency filter
223	6E		Replace the deodorization catalyst
224	6F		Simplified remote controller error
226	51		Fan motor of supply air over current or overload
227	52		Fan motor of return air over current / Fan motor of return air overload
228	53		Inverter system error (supply air side)
229	54		Inverter system error (return air side)
241	40		Humidifying valve error
242	41		Chilled water valve error
243	42		Hot water valve error
244	43		Heat exchanger of chilled water error
245	44		Heat exchanger of hot water error
258	31		The humidity sensor of return air sensor
259	32		Outdoor air humidity sensor error
260	33		Supply air temperature sensor error
261	34		Return air temperature sensor error
262	35	Outdoor air temperature sensor error	

263	36		Remote controller temperature sensor error
267	3A		Water leakage sensor 1 error
268	3H		Water leakage sensor 2 error
269	3C		Dew condensation error
339	M2		Centralized remote controller PCB error
345	M8		Communication error between centralized remote control devices
347	MA		Centralized remote control devices inappropriate combination
349	MC		Centralized remote controller address setting error
65535 (-1)	N/A	INMBSDAI001I000	Error in the communication of INMBSDAI001I000 with the AC unit

In case you detect an error code not listed, contact your nearest Daikin technical support service.