

HDMI-FMC

User Manual

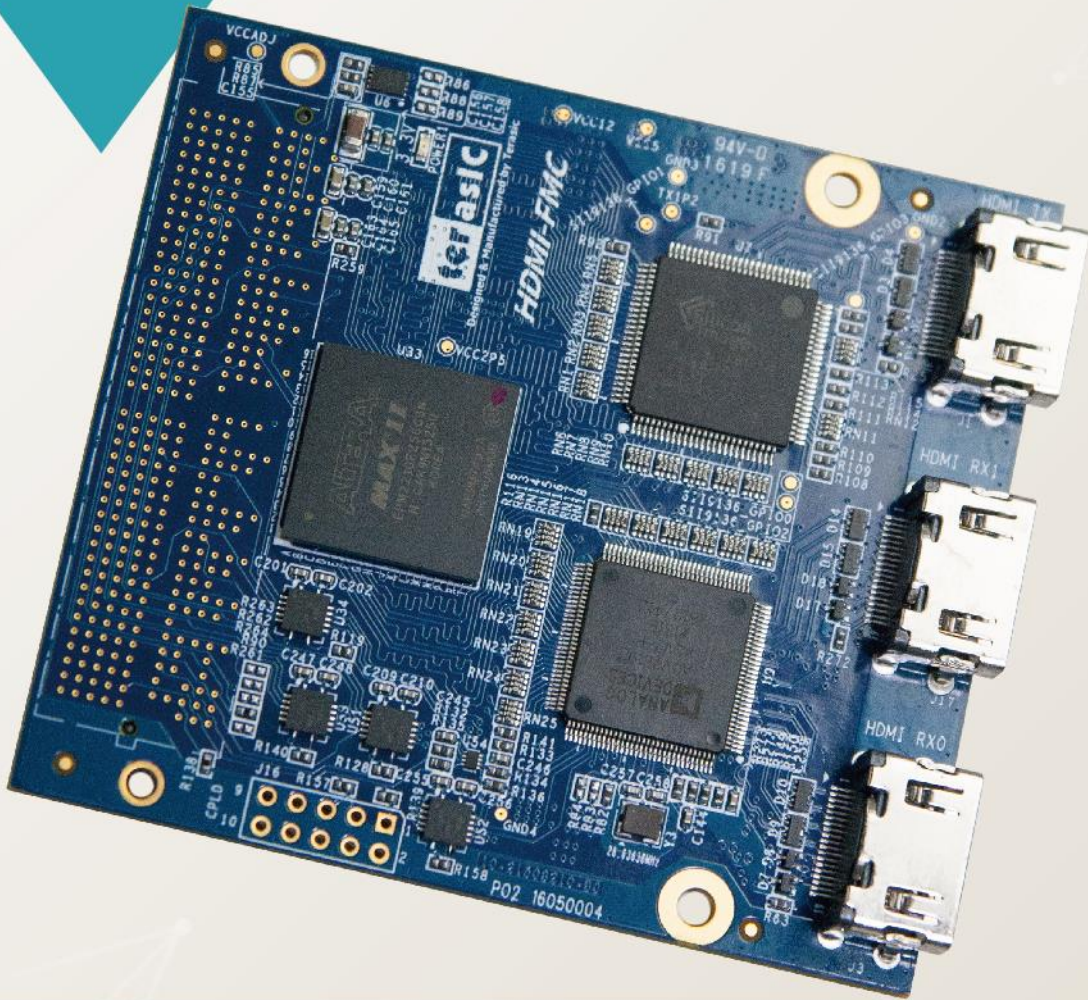

Copyright © 2003-2016 Terasic Inc. All Rights Reserved.

terasic

asic

HDMI-FMC

CONTENT

<i>Chapter 1</i>	<i>HDMI-FMC Development Kit</i>	2
	1-1 Package Contents	3
	1-2 HDMI-FMC System CD	3
	1-3 Getting Help	3
<i>Chapter 2</i>	<i>Introduction of the HDMI-FMC Card</i>	4
	2-1 Features	5
	2-2 Block Diagram of the HDMI-FMC Board	7
	2-3 Connectivity	8
<i>Chapter 3</i>	<i>Using the HDMI-FMC Board</i>	10
	3-1 Si9136-3	10
	3-2 ADV7619	26
	3-3 Level shift.....	27
	3-4 FMC Connector	29
<i>Chapter 4</i>	<i>Example Codes</i>	34
	4-1 4K HDMI Loopback Demonstration.....	34
<i>Chapter 5</i>	<i>Appendix</i>	45

Chapter 1

HDMI-FMC Development Kit

Terasic HDMI-FMC is a HDMI transmitter/receiver daughter board with FMC (FPGA Mezzanine card) interface. The user can connect the HDMI module with the FPGA development kit via the FMC connector for HDMI image & video capture, processing and display up to 4K@30fps resolution.

The HDMI-FMC provides both the HDMI Tx and Rx Module with the HDMI 1.4a features supported. The Tx module is able to supports most common standard and non-standard video input format, most common 3D formats and the video resolution up to 8-bit 4K(30Hz) 、12-bit 1080p(60Hz) 、12-bit 720p/1080i (120 Hz),and 16-bit 1080p (30 Hz). The audio interface supports S/PDIF, DSD, I2S and HBR audio format input.

The Rx module is able to support all mandatory and additional 3D video formats and extended colorimetry (sYCC601, Adobe® RGB, Adobe YCC601, xvYCC extended gamut color CEC 1.4-compatible) with up to 36-bit Deep Color. the audio interface supports S/PDIF, SACD, DSD, I2S and HBR audio format output.

We also provide complete demo source codes for the HDMI-FMC working with different FPGA development kits. These demos are created by using Verilog HDL & ALTERA VIP, by referring to these demos, users can quickly develop their own applications.

1-1 Package Contents



Figure 1-1 The HDMI-FMC package contents

The HDMI-FMC package includes:

- One HDMI-FMC module
- Screw & Copper Pillar Package
- System CD Download Guide

1-2 HDMI-FMC System CD

The HDMI-FMC System CD contains all the documents and supporting materials associated with HDMI-FMC, including the user manual, reference designs, and device datasheets. Users can download this system CD from the link: <http://hdmi-fmc.terasic.com/cd>.

1-3 Getting Help

Here are the addresses where you can get help if you encounter any problems:

Terasic Technologies

9F., No.176, Sec.2, Gongdao 5th Rd, East Dist, Hsinchu City, 30070. Taiwan

Email: support@terasic.com

Tel.: +886-3-575-0880

Website: <http://www.terasic.com>

Chapter 2

Introduction of the HDMI-FMC Card

This chapter describes the architecture and configuration of the HDMI-FMC Board including block diagram and components related.

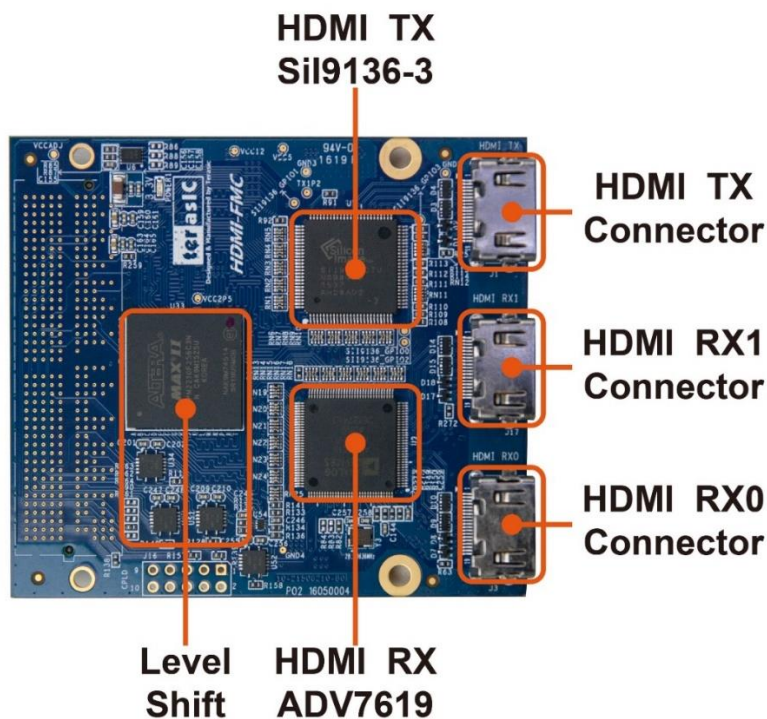
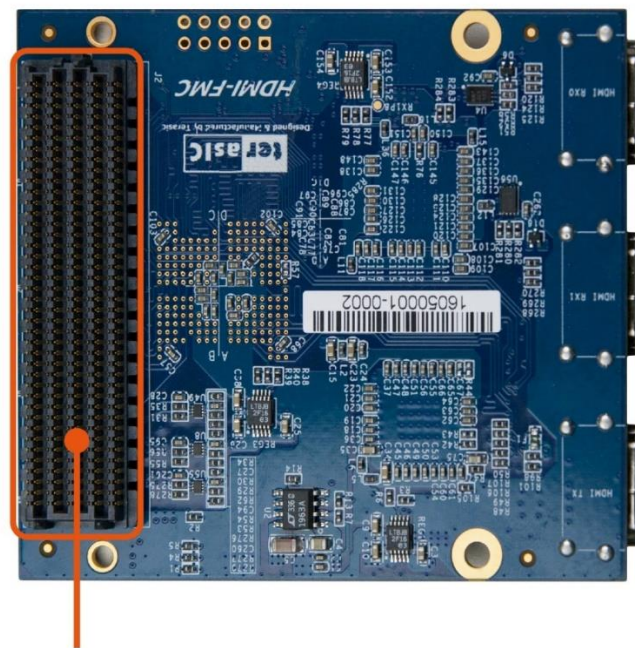

Figure 2-1 The HDMI-FMC Board PCB and Component Diagram of top side

The Photographs of the HDMI-FMC are shown in **Figure 2-1** and **Figure 2-2**. They depict the layout of the board and indicates the location of the connectors and the key components on the top and bottom side.



FMC Connector(HPC)

Figure 2-2 The HDMI-FMC Board PCB and Component Diagram of bottom side

The following components are provided on the HDMI-FMC Board:

- HDMI TX chip SiI9136-3
- HDMI TX chip ADV7619
- LEVEL Shift EPM2210
- FMC Connector (HPC)

2-1 Features

The HDMI-FMC card has many features that allow users to implement a wide range of design circuits, from simple circuits to various multimedia projects.

The following hardware is provided on the board:

Package Interface: VITA 57.1 FMC, adjustable I/O-standard(1.5/1.8/2.5V).

Tx Module:

Tx Module

Color Space	Video Format	Clock Edge Mode	Bus Width/ Color Depth	SYNC	Input Pixel Clock (MHz)								
					480i	VGA 480p	XGA	720p	1080i	SXGA	1080p	UXGA	4k
RGB	4:4:4	Single	36/12	Sep	27	25/27	65	74.25	74.25	108	148.5	—	—
		Single	30/10	Sep	27	25/27	65	74.25	74.25	108	148.5	162	—
		Single	24/8	Sep	27	25/27	65	74.25	74.25	108	148.5	162	297
		Dual	12/8	Sep	27	25/27	65	74.25	74.25	—	—	—	—
		Dual	15/10	Sep	27	25/27	65	74.25	74.25	—	—	—	—
		Dual	18/12	Sep	27	25/27	65	74.25	74.25	—	—	—	—
		Dual	24/16	Sep	27	25/27	65	74.25	74.25	—	—	—	—
YCbCr xYCC	4:4:4	Single	36/12	Sep	27	25/27	65	74.25	74.25	108	148.5	—	—
		Single	30/10	Sep	27	25/27	65	74.25	74.25	108	148.5	162	—
		Single	24/8	Sep	27	25/27	65	74.25	74.25	108	148.5	162	297
		Dual	12/8	Sep	27	25/27	65	74.25	74.25	—	—	—	—
		Dual	15/10	Sep	27	25/27	65	74.25	74.25	—	—	—	—
		Dual	18/12	Sep	27	25/27	65	74.25	74.25	—	—	—	—
		Dual	24/16	Sep	27	25/27	65	74.25	74.25	—	—	—	—
	4:2:2	Single	16/8	Sep	27	25/27	65	74.25	74.25	108	148.5	162	297
			20/10	Emb	27	25/27	65	74.25	74.25	108	148.5	162	297
		Single/ YC Mux	8/8	Sep	27	50/54	130	148.5	148.5	—	—	—	—
			10/10	Emb	27	50/54	130	148.5	148.5	—	—	—	—
			12/12	T1004	—	50/54	130	—	—	—	—	—	—
			12/12	T1004	—	50/54	130	—	—	—	—	—	—

- **Chip P/N : SiI9136-3**
- **HDMI 1.4a/1.3, HDCP 1.4 and DVI Compliant**
- **Video formats : 4:4:4 RGB, 4:4:4/4:2:2 YCbCr**
- **Pixels resolution : 4Kx2K@30Hz**
- **Pixels clock : DDR/SDR up to 300MHz**
- **3D format support**
- **High Bitrate Audio support**

Rx Module:

- Chip P/N: ADV7619
- HDMI 1.4a/1.3, HDCP 1.4 and DVI Compliant
- Video formats: 4:4:4 RGB, 4:4:4/4:2:2 YCbCr
- Pixels resolution: 3840x2160@30Hz
- Pixels clock: DDR/SDR up to 297MHz

Level Shift:

- EPM2210
- I/O-Standard (1.5/1.8/2.5V)

2-2 Block Diagram of the HDMI-FMC Board

Below **Figure 2-3** shows the HDMI-FMC Block Diagram. Level shift module outputs audio and video image data from FMC connector, which can be converted to TMDS data by passing through the Sil9136-3 to the HDMI TX connector. Similarly, HDMI RX connector receives all mandatory 3D TV formats defined in the HDMI 1.4a specification through a dual input HDMI-capable, which can be converted to audio and video image data by the ADV7619, and send to the FMC connector through Level shift. Both Sil9136-3 and ADV7619 can be controlled by FPGA I2C interface.

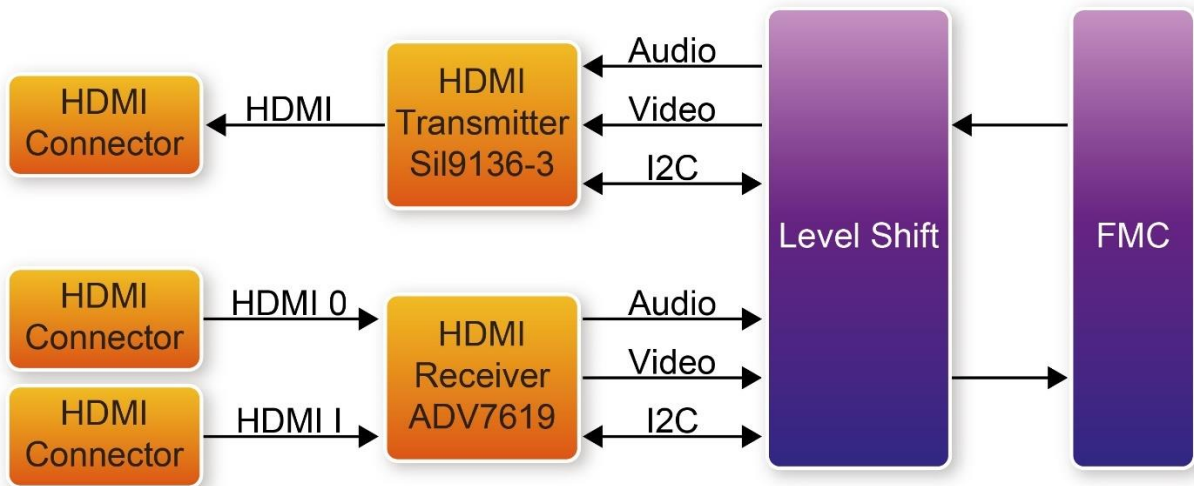

Figure 2-3 Block Diagram of the HDMI-FMC Board

2-3 Connectivity

Terasic HDMI-FMC is able to connect on to any FPGA development kit equipped with FMC (High-Pin Count) connector. The Below pictures [Figure 2-4](#), [Figure 2-5](#) and [Figure 2-6](#) show the connections with three different Terasic FPGA Boards:

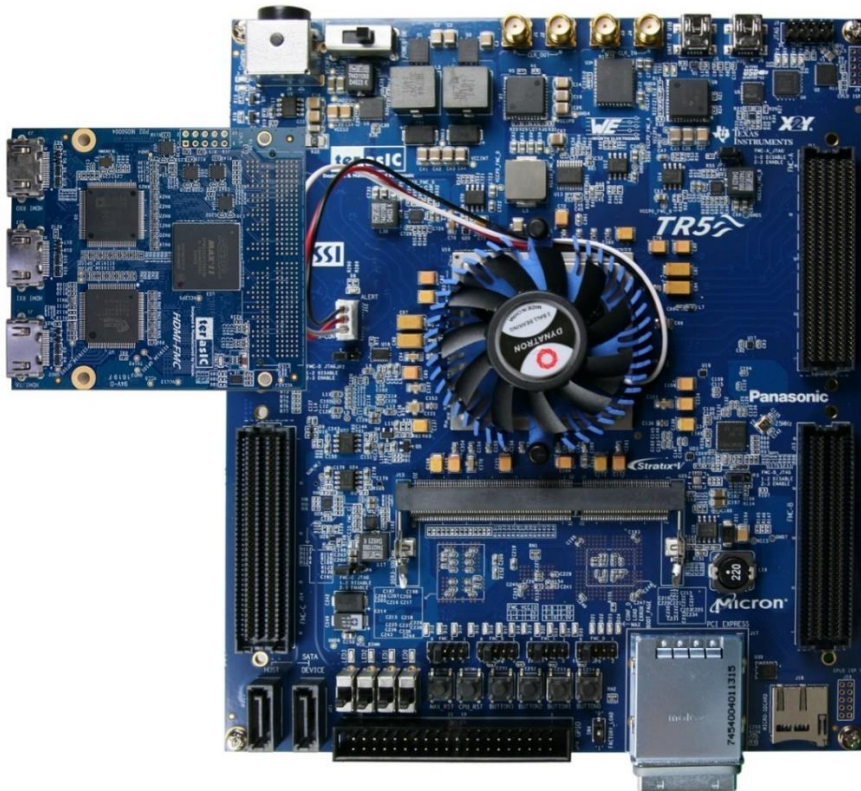

Figure 2-4 Connect the HDMI-FMC to TR5 board's FMCD port

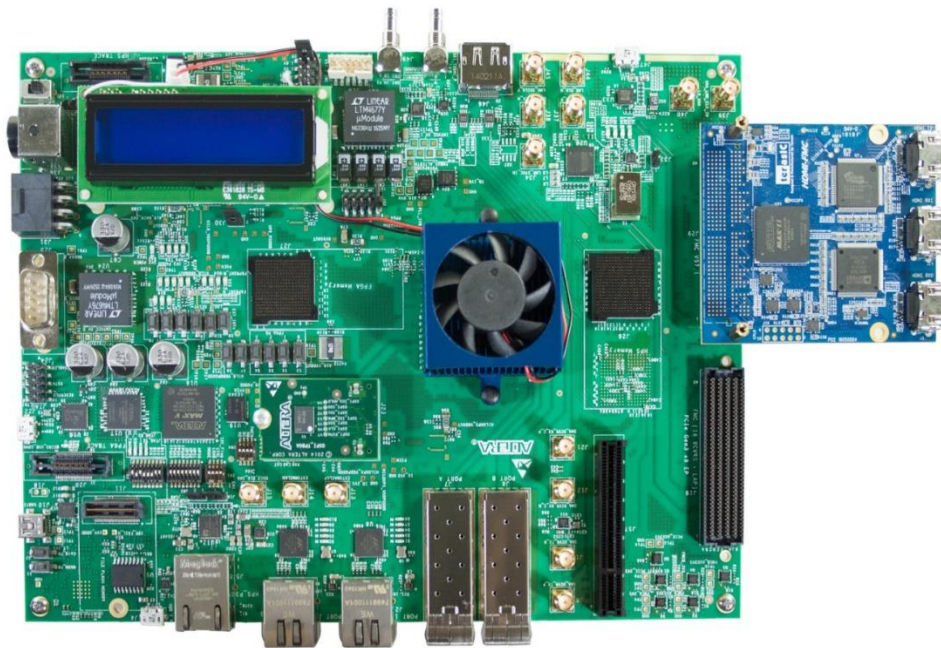

Figure 2-5 Connect the HDMI-FMC to A10SoC board's FMCA port

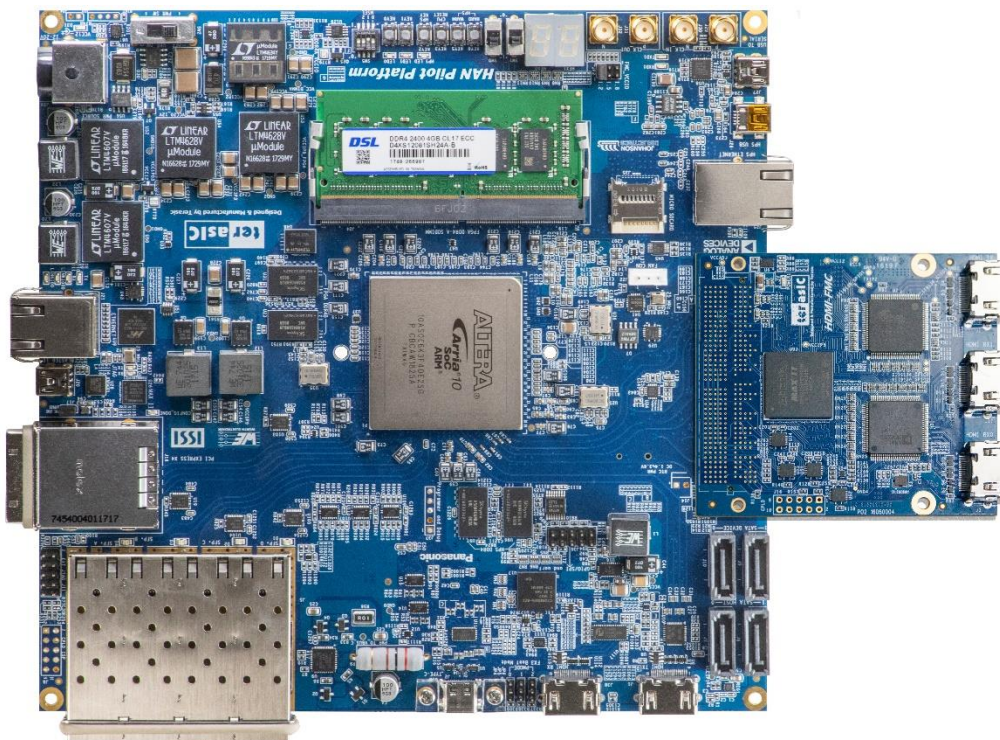

Figure 2-6 Connect the HDMI-FMC to Terasic HAN Pilot Platform FMC port

Chapter 3

Using the HDMI-FMC Board

This chapter provides instructions on how to use Sil9136-3, ADV7619, Level shift and FMC connector on the HDMI-FMC board.

3-1 Sil9136-3

Sil9136-3 is a HDMI Deep Color transmitter and can deliver up to 16-bit Deep Color at 1080p/30Hz resolutions and 12-bit Deep Color at 1080p/60Hz resolutions. It merge independent video and audio streams for transmission over HDMI. For video data input, Sil9136-3 support most standard and non-standard video input formats and resolutions up to 8-bit 4K/30Hz, 12-bit 1080p/60Hz, 12-bit 720p/120 Hz, 12-bit 1080i/120 Hz, and 16-bit 1080p/30Hz. For audio input, it supports I2S, Direct Stream Digital, and S/PDIF audio input formats.

For HDMI output, DVI and HDMI transmitter with xvYCC extended color gamut, Deep Color up to 16-bit color, and high bitrate audio are all supported. The I2C address for TPI/CR of Sil9136-3 is 0x72/0x7A. **Figure 3-1** shows the system block diagram of Sil9136-3.

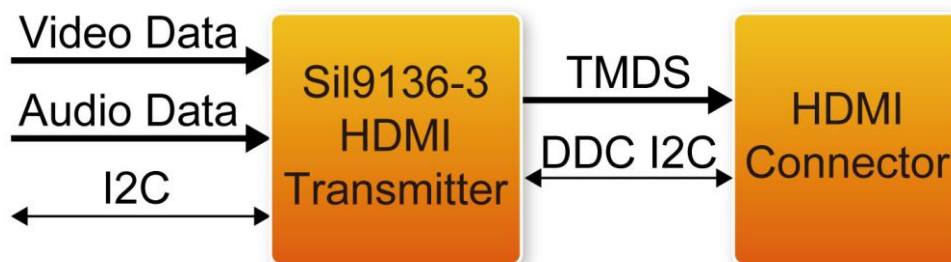

Figure 3-1 Sil9136-3 HDMI transmitter

The Sil9136-3 transmitter has four GPIO pins, and the value of each pin can be read or set through the local I2C bus. The sil9136-3 also contains a Consumer Electronics Control (CEC) interface which incorporates an HDMI-compliant CEC I/O and the Lattice CEC Programming Interface (CPI); this reduces the need for system-level control by the system microcontroller and simplifies firmware overhead.

There are individual components processing the video and audio input data. In the video data input and conversion block, the bus configurations support most standardized video input formats as well as other widely used non-standard formats. After configuration and processing, the clock, data, and sync information are combined into a complete set of signals required for further processing as follows. The upsampler and downsampler block convert the 4:2:2 sampled video to 4:4:4 and 4:4:4 sampled video to 4:2:2 separately. The two color space converters (CSCs, convert YCbCr to RGB and RGB to YCbCr) are available to interface to the many video formats supplied by A/V processors and provide full DVI backward compatibility. RGB range expression block scales the input color range from limited-range into full-range and RGB/YCbCr range compression compresses full-range data into limited-range data for each video channel. The clipping and dither function are also employed in the transmitter. The audio capture block supports I2S, Direct Stream Digital, and S/PDIF audio input formats. The appropriate registers must be configured to describe the audio format provided to the SiI9136-3 transmitter.

There is a Transition-minimized differential signaling(TMDS) transmitter for the output. The TMDS digital core performs 8-to-10-bit TMDS encoding and is then sent over three TMDS data and a TMDS clock differential lines. All of the above operations can be controlled by the configuration registers which can be accessed via the I2C interface.

■ Register Table for HDMI TX Chip

■ Internal (Indexed) Registers

Underlying the TPI register set is a broader and more complex internal register set that is normally hidden from direct access. This register set includes the legacy registers that were available in older programming methodologies, but also some additional registers that are used primarily during chip development and testing.

From time to time, situations arise that require customer software to manually access these internal registers. Therefore, a mechanism is provided for accessing single bytes. Where defined, Internal Registers are accessed as noted below.

1. Set Page	2. Select Indexed Offset within Page	3. Obtain Read/Write Register Access
0xBC	0xBD	0xBE

■ Detailed Sequences

- In the following descriptions: host refers to activities of the software for the graphics host processor.
- TPI refers to use of the I2C interface to access the TPI registers implemented in the transmitter itself.
- Tx refers to the respective transmitter chip variant. Rx refers to the HDCP registers on the remote HDMI receiver

■ Initialization

The following steps are required to prepare for operation.

Step	Function	Registers Involved	Details
1	Reset and Initialize	0xC7	host → TPI: Hardware Reset to Tx subsystem The host must reset the chip, then write 0x00 to 0x72:0xC7 to enable TPI mode.
2	Detect Revision	0x1B–0x1D	host ← TPI: Detect Tx type and TPI revision. When TPI 0x1B can be read correctly, the TPI subsystem is ready.
3	Power up transmitter	0x1E	host → TPI: Enable active mode. Write TPI 0x1E[1:0] = 00
4	Configure Input Bus and Pixel Repetition	0x08	host → TPI: Select input bus characteristics like pixel size, clock edge
5	Select YC Input Mode	0x0B	host → TPI: Select YC input mode and signal timing features
6	Configure Sync Methods	0x60–0x61	host → TPI: Choose the sync method register group to access, enable YC Mux mode
7	Configure Explicit Sync DE Generation	0x62–0x6D w/ 0x60[7] = 0	host → TPI: Define parameters for explicit sync method
8	Configure Embedded Sync Extraction	0x62–0x6D w/ 0x60[7] = 1	host → TPI: Define parameters for embedded sync method Note that the TPI 0x63 values must be rewritten after

			0x19 is written.
9	Set up Interrupt Service	0x3C	host → TPI: Enable hardware interrupts to be serviced (TPI 0x3C)

→ **Important Note:** For TPI operation, **always** write device address 0x72, register offset 0xC7 = 0x00 as the first step after hardware reset.

Step 1 above is mandatory to allow operation of the TPI register set on HDMI transmitters. If the write is not done as the first register write, the transmitter will revert to Compatible Mode register set operation; the TPI registers will not be accessible.

After powering up the transmitter, the host should write the following sequence to enable source termination.

- a) Write 0xBC=0x01 // Internal page 0
- b) Write 0xBD=0x82 // Indexed register 82
- c) Read 0xBE // Read current value
- d) Modify bit[0] = 1 // Enable source termination
- e) Write 0xBE // Write back modified value

Si9136-3 Tx only. This device requires the TMDS PLL bandwidth control to be set for 0.75x operation. After powering up the transmitter, the host should write the following sequence to set the bandwidth control for 0.75x operation.

- a) Write 0xBC=0x01 // Internal page 0
- b) Write 0xBD=0x80 // Indexed register 80
- c) Write 0xBE=0x24 // Write bandwidth control

■ Transmitter Programming Interface (TPI) Register

TPI provides a programming interface that operates at a higher hardware level than traditional register file interfaces. The TPI register groups **Table 3-1** handle all normal chip operations in a concise format.

Table 3-1 Register Group Summary

Group Function	Register Addresses	Register Name	What Firmware Does with these Registers
Identification	0x1B–1D	Identification	Identifies the chip and version of TPI

			implemented.
Input Configuration – one-time configuration of the input bus for its application environment.	0x08	Input Bus and Pixel Repetition	Selects input bus characteristics such as pixel size and clock edge
	0x0B	YC Input Mode Select	Selects YC Mux modes, signal timing features, and chooses sync method registers to access
	0x60–61	Sync Configuration and Monitoring	
	0x62–6D with 0x60[7] = 0	Explicit Sync DE Generation	Defines parameters for explicit sync method
	0x62–6D with 0x60[7] = 1	Embedded Sync Extraction	Defines parameters for embedded sync method
Audio Configuration	0x1F–0x28	Audio Configuration	Configures audio input channels and rates
Video Mode Select-resolution, color space, InfoFrame headers	0x00–0x07	Video Mode	Defines the incoming resolution
	0x09–0x0A	Input and Output Format	Defines color space, color depth
	0x0C–0x19	AVI InfoFrame	Programs header information as defined by HDMI specification
	0xBF– 0xDE	Other InfoFrame	
	0x60	YC Mux Mode	—
System Control-single-byte control for most-used functions	0x1A	System Control	Requests DDC bus access, selects between DVI/HDMI, controls TMDS output and AV Mute
Interrupt – single-byte status for monitoring significant events	0x3C–0x3D	Interrupt	Polls for and clears events, selects the interrupt events that should cause hardware INT activation
Power Control	0x1E	Power Control	Selects full-power operational mode or low-power standby mode
HDCP – automatic security	0x29–0x3A	HDCP	Sets up and monitors HDCP link security

■ TPI Identification Registers & Device ID Information

The ID registers return the device ID and TPI revision ID. The ID registers are listed in [Table 3-2](#). HDCP-capable and non HDCP-capable transmitters are distinguishable only by reading the HDCP revision register (TPI 0x30).

Access. These registers are accessed as single bytes.

Table 3-2 TPI Identification Registers (RO)

Offset	Bit 7	Bit 6	Bit 5	Bit 4	Bit 3	Bit 2	Bit 1	Bit 0
0x1B	Device ID Refer to Table 3-3							
0x1C	Device Production Revision ID revision level (major.minor) Refer to Table 3-3							
0x1D	TPI Scheme 0 = Hardware (always) 1 = Software		TPI revision level (major.minor) Refer to Table 3-3					

Table 3-3 Device ID Information

Device	Device ID TPI 0x1B	Device Production Revision ID TPI 0x1C	TPI Revision ID TPI 0x1D	HDCP Revision TPI 0x30
SiI9136-3/SiI9334 Tx	0xB4	0x20	0x30	0x12

■ **TPI Input Bus and Pixel Repetition Data**

Input Video Mode Data

The input bus clocking format, along with clocking rate and edge, are specified in this register. The video host also indicates the pixel repetition factor here.

Access. This register is accessed as a single byte.

Table 3-4 TPI Input Bus and Pixel Repetition Data (R/W)

Offset	Bit 7	Bit 6	Bit 5	Bit 4	Bit 3	Bit 2	Bit 1	Bit 0
0x08 [60]	InputBusFmt							
	TClkSel Ratio of output TMDS clock to input video clock 00 – x0.5 01 – x1 (default) 10 – x2 11 – x4		Input Bus Select 0 – half pixel wide 1 – full pixel wide (default)	Edge Select 0 – Rising edge 1 – Falling edge	PR3:0 Pixel Repetition Factor1 0000 – Pixel data is not replicated 0001 – Pixels are sent two times each 0011 – Pixels are sent four times each All others – Rsvd			

Notes

1. PR3:0 are cleared whenever TPI 0x1A[4] goes from 1 to 0.
2. The Input Clock (IDCK) and the TMDS Link Clock must be within the min/max range for the HDMI transmitter for proper operation. Once the clocks go out of range, changing the field back to the correct value may not be enough to recover. Proper recovery requires a switch into and out of power-down mode D2 (TPI 0x1E).

Input Bus Select. The input data bus can be either one pixel wide or one-half pixel wide. The bit defaults to 1 to select full pixel mode. In one-half pixel mode, the full pixel is brought in on two successive clock edges (one rising, one falling). Support is provided for 30- and 36-bit full-pixel and 15-, 18-, and 24-bit half-pixel input modes. The corresponding color depth is selected at TPI 0x09[7:6].

Edge Select. Input data is latched on the selected rising or falling clock edge. For one-half pixel mode, this bit indicates when it is 0 that data present at the falling edge is latched first, and when it is 1, data present at the rising edge is latched first. The high-order bits are latched first.

TClkSel. If the video host drives in data using anything other than a 1:1 ratio of input clock speed to TMDS clock speed, the host must program the clock multiplier logic.

■ TPI AVI

Input and Output Format

Input Format and Output Format are used by the host to specify the data format and range. At a reset event, the chip defaults set input and output to be full-range RGB.

To set these registers, the host should read the EDID to determine whether the sink is DVI or HDMI, and what its preferred output format is. Once written, the selection remains until overwritten or until the next reset event.

Input Color Space / Output Format. These bits should be set as needed. The settings made to these bits do not take effect until the AVI InfoFrame registers are programmed, so that any color space change can be synchronized to the color settings specified in the InfoFrame (avoiding temporarily green or pink images).

Range Compression. Range compression is enabled when RGB input and YCbCr output conversion is selected.

Range Expansion. Range expansion is enabled when YCbCr input and RGB output conversion is selected.

Range Override. Range expansion is associated with the input format; the range bits either force expansion (01) or block it (10). Range compression is associated with the output format; the range bits either block compression (01) or force it (10).

Input Color Depth. This setting selects the incoming bus width to allow for proper handling on output. Note that only two YCbCr input bus widths, 8-bit and 12-bit, are possible. For 4:2:2 inputs 9, 10, or 11 bits wide, the host should set TPI 0x09[7:6] = 11 (12 bits), and drive unused bits of the video stream to 0.

Black Mode. This setting disables the video data input bus, forcing the video output to black (as long as valid video clock and control inputs are still available). This setting should not be used when HDCP is enabled, as the screen will show snow.

Access. These registers can be accessed individually or by bursts as desired. For writes, the actual write to the HDMI transmitter logic takes place only once the final byte of the burst write to TPI 0x0C-19 occurs (refer to Input Color Space/ Output Format note above).

Table 3-5 TPI AVI Input and Output Format Data (R/W)

Offset	Bit 7	Bit 6	Bit 5	Bit 4	Bit 3	Bit 2	Bit 1	Bit 0
0x09	InputFormat							
[00]	Input Color Depth 00 – 8-bit 01 – 16-bit 10 – 10-bit (10/12-bit undithered for 4:2:2 mode) 11 – 12-bit (10/12-bit dithered to 8, for 4:2:2 mode)		Rsvd		Video Range Expansion 00 – Auto-selected by [1:0] 01 – On 10 – Off 11 – Rsvd		Input Color Space 00 – RGB 01 – YCbCr 4:4:4 10 – YCbCr 4:2:2 11 – Black Mode 1	
0x0A	OutputFormat							
[00]	Output Color Depth2 00 – 8-bit (also used for 4:2:2 mode) 01 – 16-bit 10 – 10-bit 11 – 12-bit	Dither from Input Depth to Output Depth 0 – Disable 1 – Enable	Color Space Standard 0 – BT.601 conversion 1 – BT.709 conversion		Video Range Compression 00 – Auto-selected by [1:0] 01 – Off 10 – On 11 – Rsvd		Output Format 00 – RGB 01 – YCbCr 4:4:4 10 – YCbCr 4:2:2 11 – RGB (same as 00)	

Notes:

1. The blanking levels for Black Mode vary based on color space and video range. Before setting TPI 0x09[1:0] = 3, set the TPI Video Mute Registers, TPI 0x4A through TPI 0x4F.
2. Do not use Output Color Deep field values that may cause the output frequency exceed 300 MHz. Once the clocks go out of range, changing the field back to the correct value may not be enough to recover. Proper recovery requires a switch into and out of power-down mode D2 (TPI 0x1E).

Deep Color Operation. Deep Color settings can be used where supported by the HDMI sink device. The following additional configuration is required.

General Control Packet – Deep Color settings require the General Control Packet to be sent once per video field with the correct PP and CD information. This must be enabled by software via the Deep Color Packet Enable TPI 0x40[2] = 1, enable transmission of the GCP packet.

Output Color Depth – This setting selects the color depth for the HDMI output stream, and also selects the corresponding HDMI protocol handling. It should be left at 8-bit for YCbCr 4:2:2 modes, as well as for any non-Deep Color mode of operation. Unlike the other bits in this register, any output color depth setting change takes place immediately and is not dependent on a write to the AVI InfoFrame registers.

Note: Selecting any Deep Color output mode is done directly through TPI 0x0A[7:6]. However, if it is later necessary to switch back to 8-bit color depth, switch to 16-bit Deep Color first, and then to 8-bit color depth.

Dither from Input Depth to Output Depth – When the incoming data contains greater color depth than the attached HDMI source is capable of handling, this bit can be set to dither the HDMI output based on the least significant bits of the input, and thereby achieve greater color accuracy. For example, if TPI 0x09[7:6] = 01, 16-bit input depth, and TPI 0x0A[7:6] = 10, 10-bit output depth, setting TPI 0x0A[5] = 1 dithers from 16-bit input to 10-bit output depth.

Video Mute Operation. The Black Level data is related to the Video Input Mode (RGB / YCbCr 444, YCbCr422) and Input width (8, 10, 12, and 16) are programmable.

■ Sync Generation Options

For input video modes that do not provide explicit HSYNC, VSYNC, and/or DE signals, the transmitter logic offers two methods for sync signal generation:

- DE Generation (when explicit HSYNC and VSYNC signals are provided)
- Sync Extraction (when incoming video uses the ITU 656 method for embedding sync)

information).

The register sets for both modes overlap, so only one can be accessed at a time. However, by toggling between the two groups, features from both can be intermixed.

The registers available at TPI 0x62–0x6D depend on the setting of TPI 0x60[7].

- Setting TPI 0x60[7] = 0 selects external sync and access to the DE Generator registers. The DE signal can be generated internally and sent over TMDS if TPI 0x62–0x6D are set and then TPI 0x63[6] is set to 1.
- Setting TPI 0x60[7] = 1 allows access to the Embedded Sync Extraction registers. The DE, HSYNC, and VSYNC signals can then be extracted and sent over TMDS if TPI 0x62–0x69 are set and then TPI 0x63[6] is set to 1.

Features from both groups can be enabled together, by enabling the features of each group with TPI 0x60[7] set appropriately.

Access. These registers are accessed as single bytes or as part of a burst.

Table 3-6 Sync Register Configuration and Sync Monitoring Registers

Offset	Bit 7	Bit 6	Bit 5	Bit 4	Bit 3	Bit 2	Bit 1	Bit 0
0x60 [04]	Sync Generation Control Register							
	Sync Method 0 – External 1 – Embedded	RSVD	YC Mux Mode One- to two-data-channel de-mux 0 – Disable 1 – Enable	Invert Field Polarity 0 – Leave bit as is 1 – Invert field bit	RSVD	DE_ADJ# 0 – Enable (recommended) 1 – Disable (default)	F2VADJ Adjust VBIT to VSYNC per bit [0] 0 – Disable (default) 1 – Enable	F2VOFST Adjust VBIT to VSYNC if bit [1] = 1 0-Decrement by 1 1 –Increment by 1
0x61 [00]	Video Sync Polarity Detection Register (RO)							
	RSVD	RSVD	RSVD	RSVD	RSVD	Interlace Mode detected 0 – non interlaced 1 – interlaced	Input VSYNC polarity detected 0 – active high (leading edge rises)	Input HSYNC polarity detected 0 – active high (leading edge

							1 – active low (leading edge falls)	rises) 1 – active low (leading edge falls)
--	--	--	--	--	--	--	---	---

DE_ADJ# enables detection circuits to locate the position of VSYNC relative to HSYNC and only include HSYNC edges that are greater than three-fourths of a line from VSYNC in the line count for DE_TOP. Clearing this bit enables the function and is recommended for normal operation. Setting it high disables VSYNC adjustments and is not a recommended setting.

F2VADJ adjusts the VBIT_TO_VSYNC value during field 2 of an interlace frame; **F2VOFST** sets the direction of adjustment (increment or decrement by 1).

Invert Field Polarity. The Invert Field Polarity bit is used when the 656 Flag Bit is opposite the standard polarity for Field1 and Field2. Inverting polarity causes the sync extraction to format HSYNC and VSYNC properly based on the Fbit. In embedded sync mode, the transmitter does not detect even from odd field, except based on the setting of the F-bit. With explicit syncs, the transmitter encodes HSYNC and VSYNC across the HDMI/TMDS link without regard for field sequence.

■ I2S Input Configuration Register

Configuring Audio Using I²S

The I2S audio subsystem selection is made by TPI control.

I2S Initialization and Operation

The transmitter requires the following initialization for I2S applications.

1. Ensure that a valid I2S audio stream is coming into the transmitter.
2. Select I2S input mode using TPI 0x26[7:6], with Mute enabled (bit [4] = 1).
3. Write register TPI 0x20 to select the general incoming SD format.
4. Write register TPI 0x1F up to four times, to program each of the SD inputs.
5. Program register TPI 0x27[5:3] with the correct audio rate.
6. Program registers TPI 0x21–0x25 with the correct header information for the stream that will be sent over HDMI.
7. Write registers TPI 0xBF–0xCD with the appropriate Audio InfoFrame information.
8. Set the audio packet header layout indicator to 2-channel or multi-channel mode as needed using the sequence described below. Note that Audio InfoFrame byte 1 must also have this same setting.
9. Again write register TPI 0x26 with I2S selected, this time with Mute disabled (bit [4] = 0).

Table 3-7 Configuration of I2S Interface (RW)

Offset	Bit 7	Bit 6	Bit 5	Bit 4	Bit 3	Bit 2	Bit 1	Bit 0
0x20 [95]	I2S Input Configuration Register							
	SCK Sample Edge 0 – Falling (change data on rising edge) 1 – Rising	MCLK Multiplier – the Tx uses these bits to divide the MCLK input to produce CTS values according to the $128 \cdot fs$ formula. The MCLK-to- fs ratio is for input fs , not down-sampled output fs . 000 – 128 100 – 768 001 – 256 101 – 1024 010 – 384 110 – 1152 011 – 512 111 – 192	WS Polarity – Left when: 0 – WS is Low 1 – WS is High	SD Justify Data is justified: 0 – Left 1 – Right	SD Direction Byte shifted first: 0 – MSB 1 – LSB	WS to SD First Bit Shift? 0 – No Yes (per spec) 1 – No		

■ **Mapping of I2S Interface**

Software typically writes TPI 0x1F multiple times, with a separate FIFO selected each time, to assign SD pins to FIFOs. A single SD pin may be connected to multiple FIFOs. For example, the same SD0 pin could be assigned to FIFO#0, FIFO#1, FIFO#2, and FIFO#3 to provide eight audio output channels. Unused FIFOs can be assigned to disabled SD inputs. No gaps are allowed when mapping channels to FIFOs; SD pins must be mapped to FIFO#0 and FIFO#1 before mapping a channel to FIFO#2, and so on.

Table 3-8 Mapping of I2S Interface (RW)

Offset	Bit 7	Bit 6	Bit 5	Bit 4	Bit 3	Bit 2	Bit 1	Bit 0
0x1F [00]	I2S Enable and Mapping Register ¹							
	SD pin selected by [5:4] 0 – Disable 1 – Enable	RSVD	Select SD pin to be connected to a FIFO 00 – SD0 01 – SD1 10 – SD2 11 – SD3	Automatic down-sample to Basic Audio mode (FIFO#0 only) 0 – Disable 1 – Enable	Swap Left / Right I2S channels on this channel 0 – No swap 1 – Swap	This FIFO will take its input from the SD pin selected in bits [5:4] 00 – FIFO#0 01 – FIFO#1 10 – FIFO#2 11 – FIFO#3		

Notes: Reads of this register return the last value written, so the readback value has meaning only for the channel most recently configured.

■ **Stream Header Settings for I2S (RW)**

Use TPI 0x25[3:0] to select the word length to be indicated to the receiver as shown in [Table 3-9](#).

Table 3-9 Stream Header Settings for I2S (RW)

Offset	Bit 7	Bit 6	Bit 5	Bit 4	Bit 3	Bit 2	Bit 1	Bit 0
0x21	I2S Channel Status Byte 0							
[00]	cbit7	cbit6	cbit5	cbit4	cbit3	cbit2	cbit1	cbit0
0x22	I2S Channel Status Byte 1: Category Code							
[00]	cbit15	cbit14	cbit13	cbit12	cbit11	cbit10	cbit9	cbit8
0x23	I²S Channel Status Byte 2: Source, Channel Number							
[00]	I2S Channel Number cbit23:20				I2S Source Number cbit19:16			
0x24	I2S Channel Status Byte 3: Accuracy, Sampling f_s							
[0F]	Clock Accuracy cbit31:28				Sampling Frequency cbit27:24 0000 – 44.1kHz 1000 – 88.2kHz 1100 – 176.4kHz 0010 – 48kHz 1010 – 96kHz 1110 – 192kHz 0011 – 32kHz 1001 – 768 kHz (HBRA) 0001 – not indicated			
0x25	I2S Channel Status Byte 4: Original f_s, Sample Length							
[0B]	Original f_s , Channel Status bits 39:36 Refer to IEC60958 specification				Sample Length, Channel Status bits 35:32 Word Length 1011 – 24 bits (default) 1001 – 23 bits 0101 – 22 bits 1101 – 21 bits 1010 – 20 bits 1000 – 19 bits 0100 – 18 bits			

		1100 – 17 bits
		0010 – 16 bits

Note: These registers are available **only** when TPI 0x26[7:6] = 10 to select I2S input.

■ Interrupt Enable Register

The Interrupt Enable Register enables TPI and transmitter to generate interrupts to the host. Hot plug interrupts to the host are generated even in the D3 (low-power) state. Writing any bit to 1 enables the interrupt source, and also clears any pending interrupts. Writing 0 to disable the interrupt does not clear any previously pending interrupt.

Access. This register is accessed as a single byte

Table 3-10 TPI Interrupt Enable (R/W)

Offset	Bit 7	Bit 6	Bit 5	Bit 4	Bit 3	Bit 2	Bit 1	Bit 0
0x3C [00]	HDCP Authentication Status Change 0 – Disable 1 – Enable	HDCP V* Value ready 0 – Disable 1 – Enable	Security Status Change 0 – Disable 1 – Enable	Audio Error Event 0 – Disable 1 – Enable	CPI Event in place of Rx Sense 0 – Disable 1 – Enable	RSVD	Receiver Sense Event 0 – Disable 1 – Enable	Hot Plug / Connection (cable plugged/unplugged) Event 0 – Disable 1 – Enable

■ Interrupt Status Register

The Interrupt Status Register shows current status of interrupt events, even if the event has been disabled. This register can be polled for activity if the associated interrupt has been disabled. Write 1 to interrupt bits to clear the pending status. Bits 3 and 2 (bits 3:0 on Mobile HD Link devices) serve only to show the current state and cannot be cleared.

Access. This register is accessed as a single byte

Table 3-11 TPI Interrupt Status (R/W)

Offset	Bit 7	Bit 6	Bit 5	Bit 4	Bit 3	Bit 2	Bit 1	Bit 0
0x3D [00]	HDCP Authentication status change	HDCP V* Value ready	Security Status Change	Audio Error Event	RxSense current state or	Hot Plug pin current state or	Receiver Sense Event pending or	Hot Plug / Connection Event pending

	Event pending 0 – No 1 – Yes	Event pending 0 – No 1 – Yes	Event pending 0 – No 1 – Yes	pending 0 – No 1 – Yes	CPI Event pending state (RO) 0 – No Rx sensed/CPI 1 – Powered Rx attached/ CPI event pending	CTRL Bus Transaction Event pending state (RO) 0 – HP Low or no event pending 1 – HP High or CTRL event pending	CTRL Bus Error indicated 0 – No 1 – Yes	0 – No 1 – Yes
0x3E [00]	RSVD						Received first byte of KSV 0 – No 1 – Yes	HDMI Link Stable 0 – No 1 – Yes
0x3F [00]	RSVD						Interrupt Control Received first Byte of KSV 0 – Disable 1- Enable	Interrupt Control HDMI Link Stable 0 – Disable 1 – Enable

Hot Plug / Connection. The Hot Plug *state* (HTPLG signal from the DVI or HDMI sink) indicates whether a display is attached (the EDID is readable, but the display is not necessarily powered up). The Hot Plug *event* indicates whether the state has changed.

Receiver Sense. The Receiver Sense *state* (RxSense signal from HDCP) indicates whether a powered-up receiver is sensed (whether the TMDS lines are being pulled externally to 3.3V). The Receiver Sense *event* indicates whether the state has changed.

CPI Event. Even though the CPI register set is accessed at a completely separate I2C slave address, CPI event pending status can optionally be reflected in the TPI Interrupt Status register in place of the Receiver Sense status bit. In this way, a single register read is adequate to check all interrupt sources at once. Setting TPI 0x3C[3] = 1 allows

TPI 0x3D[3] to indicate a CPI Event Pending status. Note that the event itself must be cleared from the CPI registers (writing 1 to TPI 0x3D[3] has no effect).

To further clarify: Setting TPI 0x3C[3] = 1 simply allows the CPI interrupt pending status registers to reflect into TPI

0x3D[3]. The interrupt is caused by enabling its source in the CPI registers, not by setting TPI 0x3C[3] = 1; the interrupt would happen even if this bit were 0. It is only a convenient way to be able to see the pending CPI interrupt status from the main TPI interrupt register.

Audio Error. The Audio Error event indicates that an event related to the incoming S/PDIF audio stream has been detected and handled automatically. The most common event is a change in audio header *fs* information. The hardware handles the event without a need for intervention, but the host can use this interrupt to read back the updated status information. No audio events related to I2S input are reported.

Security Status Change. Any change in the link status value (TPI 0x29[5:4]) generates a Security Status Change event so the host can take appropriate action to re-establish the link.

HDCP V* Value Ready. Once a V* value is selected, this event indicates that the computation has completed and the value is available (TPI 0x31[3] = 1).

HDCP Authentication Status Change. An authentication status change event reflects changes in TPI 0x29[7:6], indicating that:

- The previous authentication request (from a write to the Protection Level bit) has completed successfully.
- The extended authentication process failed to complete within ~5s.
- An Ri mismatch has caused authentication to fail.

■ TPI System Reset and Control

The transmitter subsystem has additional control necessary from the firmware

Table 3-12 TPI Soft Reset (R/W)

Offset	Bit 7	Bit 6	Bit 5	Bit 4	Bit 3	Bit 2	Bit 1	Bit 0
0x40 [00]	TPI Soft Reset and Control							
	Alternative TMDS Clock Stable 0 = Unstable 1 = Stable	TMDS Clock Stable 0 = Unstable 1 = Stable	RSVD			Deep Color GCP Packet 0 = Disable 1 = Enable	RSVD	Software Reset 0 = Disable 1 = Enable

Software Reset – Reset all sections, including the audio FIFO, except registers that are user configurable.

Software Reset may affect I2C communication with the CPI module. To avoid this issue perform the following:

1. Set W equal to the number of write accesses to the CPI module (I2C address 0xC0 or 0xC4).
2. Calculate $N = 8 - (W \bmod 8)$, where W is the number of write accesses from step 1.
3. Before executing the Software Reset, perform N writes (from step 2) into any of the CPI page (I2C address 0xC0 or 0xC4) registers 0x00 through 0x07.
4. Execute Software Reset by setting and clearing bit 0 in TPI 0x40 register.

Note: Software Reset is required on any input pixel clock IDCK change or interruption.

Deep Color GCP Packet – Enable the General Control Packet transmission for Deep Color operation.

TMDS Clock Stable – IDCK to TMDS clock is stable and the transmitter can send reliable data on the TMDS link. A change to the IDCK sets this bit LOW. Along with a status bit for TMDS Clock Stable there is a TPI Interrupt (TPI 0x3E[0]) for TMDS Clock Stable and a corresponding Interrupt Enable (TPI 0x3F[0]).

Alternative TMDS Clock Stable – Similar to TMDS Clock Stable, but uses alternative method for clock checking. There is no interrupt associated with this bit change.

3-2 ADV7619

A DV7619 is a high quality with two input ports and one output multiplexed High-Definition Multimedia Interface receiver. It supports all mandatory 3D TV formats defined in the HDMI 1.4 specification, HDTV formats up to 1080p 36-bit Deep Color/2160p 8-bit, and display resolutions up to $4k \times 2k$ (3840×2160 at 30 Hz).

ADV7619 also supports extended colorimetry, including sYCC601, Adobe RGB, Adobe YCC601, xvYCC extended gamut color with a dual input HDMI-cable and 297MHz maximum TMDS clock frequency. The audio interface supports HBR · DSD · S/PDIF · SACD and four I2S output format. The receiver has advanced audio functionality, such as a mute controller, that prevents audible extraneous noise in the audio output. **Figure 3-2** shows the system block diagram of ADV7619.

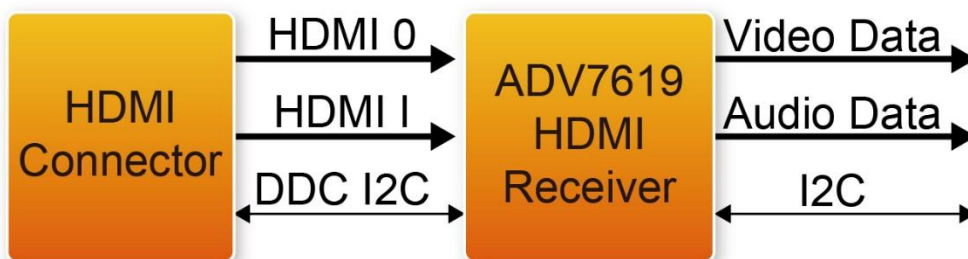

Figure 3-2 ADV7619 HDMI receiver

The HDMI-compatible receiver on the ADV7619 allows active equalization of the HDMI data signals. This equalization compensates for the high frequency losses inherent in HDMI and DVI cabling, especially at longer cable lengths and higher frequencies. The HDMI-compatible receiver is capable of equalizing for cable lengths up to 30 meters to achieve robust receiver performance.

For video format with pixel clock higher than 170MHz, the video signals received on the HDMI receiver are outputted directly to the pixel port output. To accommodate the higher bandwidth required for these higher resolutions, the output on the pixel bus consists of two 24-bit buses running at up to 150 MHz: one bus contains the even pixels, and the other bus contains the odd pixels. When these two buses are combined, they allow the transfer of video data with pixel clocks up to 300 MHz. In this mode, both 4:4:4 RGB 8-bit and 4:2:2 12-bit are supported.

■ Register Table for HDMI RX Chip

Please refer to ADV7619 Datasheet and ADV7619 Reference Manual (UG-237) in the HDMI-FMC_v.1.1.0_SystemCD.zip\Datasheet for the register tables of HDMI Receiver chip (ADV7619).

3-3 Level shift

For the voltage matching between FMC connector and HDMI transmitter/receiver IC, EPM2210, LSF0102 and TXB0104 are employed for the level shift. For HDMI transmitter/receiver IC, the I/O voltage is 3.3V while the I/O voltage of all four FMC connectors is adjustable within 1.2/1.5/1.8/2.5V.

The MAX II architecture supports the MultiVolt I/O interface feature, which allow the EPM2210 to interface with systems of different supply voltages. EPM2210 has one set of VCC pins for internal operation(VCCINT), and up to four sets for input buffering and I/O output drivers buffers(VCCIO). Users can connect VCCIO pins to either a 1.5/1.8/2.5V power supply, depending on the output requirement. The output levels are compatible with systems of the same voltage as the power supply. When VCCIO pins are connect to 2.5V power supply, the output high is 2.5V and is compatible with 2.5V systems.

LSF0102 is a 2 channel bidirectional voltage level translator operational from 0.95 to 4.5 V on A port 1.8 to 5.5 V on B port. TXB0104 is a 4-bit bidirectional voltage level translator with auto direction sensing operational 1.2 to 3.6 V on A port and 1.65 to 5.5 V on B port. LSF0102 and TXB0104 are employed for the voltage translation of I2C and audio data.

Figure 3-3, Figure 3-4, Figure 3-5 gives an illustration of the level shift.

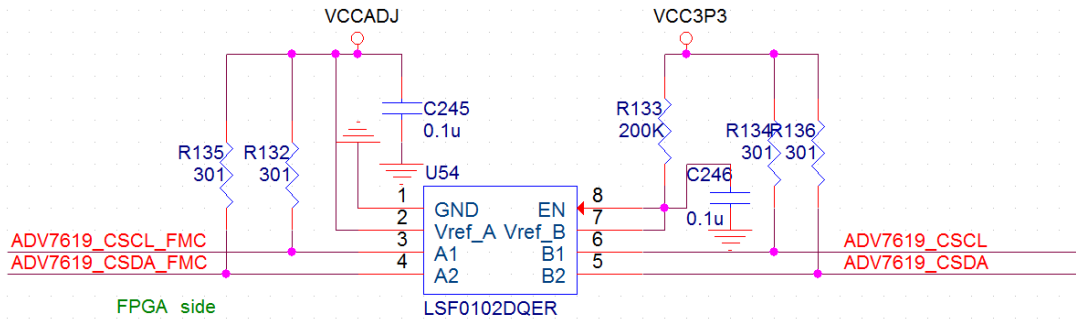

Figure 3-3 Voltage translation of I2C for Receiver

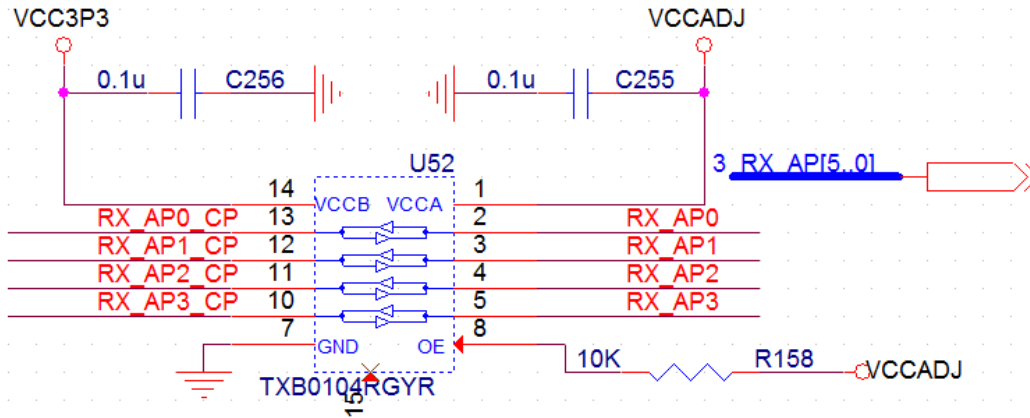

Figure 3-4 Voltage translation of audio data for receiver

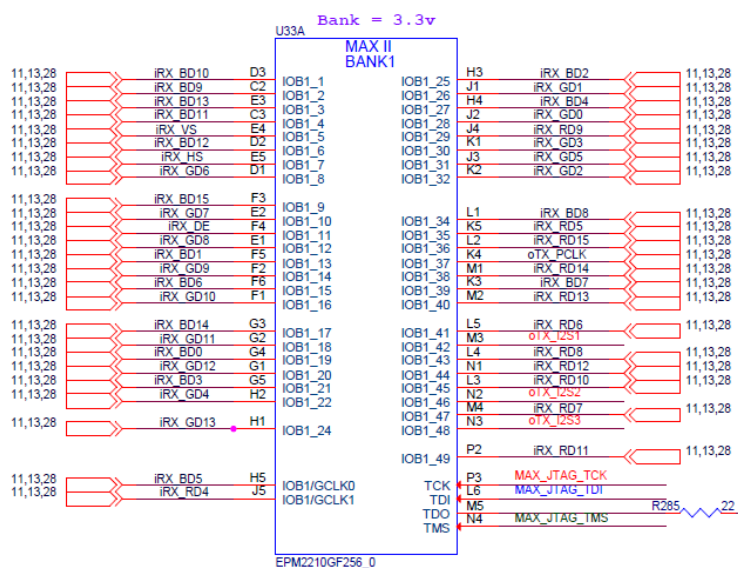

Figure 3-5 Level shift (EPM2210)

3-4 FMC Connector

Table 3-13 shows the pin out and pin definitions of the FMC connector.

Table 3-13 Pin Assignment of HDMI-FMC FMC interface

Signal Name	Pin Direction	Description	I/O Standard
TX_PCLK	Input	Transmitter pixel data clock	1.5/1.8/2.5V
TX_HS	Input	Transmitter Horizontal Synchronization signal	1.5/1.8/2.5V
TX_VS	Input	Transmitter Vertical Synchronization signal	1.5/1.8/2.5V
TX_DE	Input	Transmitter data enable	1.5/1.8/2.5V
TX_BD0	Input	Transmitter video blue data 0	1.5/1.8/2.5V
TX_BD1	Input	Transmitter video blue data 1	1.5/1.8/2.5V
TX_BD2	Input	Transmitter video blue data 2	1.5/1.8/2.5V
TX_BD3	Input	Transmitter video blue data 3	1.5/1.8/2.5V
TX_BD4	Input	Transmitter video blue data 4	1.5/1.8/2.5V
TX_BD5	Input	Transmitter video blue data 5	1.5/1.8/2.5V
TX_BD6	Input	Transmitter video blue data 6	1.5/1.8/2.5V
TX_BD7	Input	Transmitter video blue data 7	1.5/1.8/2.5V
TX_BD8	Input	Transmitter video blue data 8	1.5/1.8/2.5V

TX_BD9	Input	Transmitter video blue data 9	1.5/1.8/2.5V
TX_BD10	Input	Transmitter video blue data 10	1.5/1.8/2.5V
TX_BD11	Input	Transmitter video blue data 11	1.5/1.8/2.5V
TX_GD0	Input	Transmitter video green data 0	1.5/1.8/2.5V
TX_GD1	Input	Transmitter video green data 1	1.5/1.8/2.5V
TX_GD2	Input	Transmitter video green data 2	1.5/1.8/2.5V
TX_GD3	Input	Transmitter video green data 3	1.5/1.8/2.5V
TX_GD4	Input	Transmitter video green data 4	1.5/1.8/2.5V
TX_GD5	Input	Transmitter video green data 5	1.5/1.8/2.5V
TX_GD6	Input	Transmitter video green data 6	1.5/1.8/2.5V
TX_GD7	Input	Transmitter video green data 7	1.5/1.8/2.5V
TX_GD8	Input	Transmitter video green data 8	1.5/1.8/2.5V
TX_GD9	Input	Transmitter video green data 9	1.5/1.8/2.5V
TX_GD10	Input	Transmitter video green data 10	1.5/1.8/2.5V
TX_GD11	Input	Transmitter video green data 11	1.5/1.8/2.5V
TX_RD0	Input	Transmitter video red data 0	1.5/1.8/2.5V
TX_RD1	Input	Transmitter video red data 1	1.5/1.8/2.5V
TX_RD2	Input	Transmitter video red data 2	1.5/1.8/2.5V
TX_RD3	Input	Transmitter video red data 3	1.5/1.8/2.5V
TX_RD4	Input	Transmitter video red data 4	1.5/1.8/2.5V
TX_RD5	Input	Transmitter video red data 5	1.5/1.8/2.5V
TX_RD6	Input	Transmitter video red data 6	1.5/1.8/2.5V
TX_RD7	Input	Transmitter video red data 7	1.5/1.8/2.5V
TX_RD8	Input	Transmitter video red data 8	1.5/1.8/2.5V
TX_RD9	Input	Transmitter video red data 9	1.5/1.8/2.5V
TX_RD10	Input	Transmitter video red data 10	1.5/1.8/2.5V
TX_RD11	Input	Transmitter video red data 11	1.5/1.8/2.5V
TX_MCLK	Input	Transmitter audio input master clock(I2S、S/PDIF Mode)	1.5/1.8/2.5V
TX_SCK	Input	Transmitter I2S serial clock(I2S、S/PDIF Mode)、DSD clock(DSD Mode)	1.5/1.8/2.5V

TX_WS	Input	Transmitter I2S word select(I2S、 S/PDIF Mode)、 DSD data (DSD Mode)	1.5/1.8/2.5V
TX_SPDIF	Input	Transmitter S/PDIF input.(SPDIF Mode)、 DSD data (DSD Mode)	1.5/1.8/2.5V
TX_I2S0	Input	Transmitter I2S data 0(I2S、 S/PDIF Mode)	1.5/1.8/2.5V
TX_I2S1	Input	Transmitter I2S data 1(I2S、 S/PDIF Mode)	1.5/1.8/2.5V
TX_I2S2	Input	Transmitter I2S data 2(I2S、 S/PDIF Mode)	1.5/1.8/2.5V
TX_I2S3	Input	Transmitter I2S data 3(I2S、 S/PDIF Mode)	1.5/1.8/2.5V
TX_DSR3R	Input	Transmitter DSD data(DSD Mode)	1.5/1.8/2.5V
TX_DSR3L	Input	Transmitter DSD data(DSD Mode)	1.5/1.8/2.5V
SIL9136_RST_N	Input	Transmitter asynchronous reset signal, active low	1.5/1.8/2.5V
SIL9136_INT	Output	Transmitter interrupt signal	1.5/1.8/2.5V
SIL9136_CSCL_FM C	Input	Transmitter configuration/status I2C serial clock	1.5/1.8/2.5V
SIL9136_CSDA_FM C	Input/Output	Transmitter configuration/status I2C serial data	1.5/1.8/2.5V
RX_PCLK	Output	Receiver pixel data clock	1.5/1.8/2.5V
RX_HS	Output	Receiver Horizontal Synchronization signal	1.5/1.8/2.5V
RX_VS	Output	Receiver Vertical Synchronization signal	1.5/1.8/2.5V
RX_DE	Output	Receiver data enable	1.5/1.8/2.5V
RX_BD0	Output	Receiver video blue data 0	1.5/1.8/2.5V
RX_BD1	Output	Receiver video blue data 1	1.5/1.8/2.5V
RX_BD2	Output	Receiver video blue data 2	1.5/1.8/2.5V
RX_BD3	Output	Receiver video blue data 3	1.5/1.8/2.5V
RX_BD4	Output	Receiver video blue data 4	1.5/1.8/2.5V

RX_BD5	Output	Receiver video blue data 5	1.5/1.8/2.5V
RX_BD6	Output	Receiver video blue data 6	1.5/1.8/2.5V
RX_BD7	Output	Receiver video blue data 7	1.5/1.8/2.5V
RX_BD8	Output	Receiver video blue data 8	1.5/1.8/2.5V
RX_BD9	Output	Receiver video blue data 9	1.5/1.8/2.5V
RX_BD10	Output	Receiver video blue data 10	1.5/1.8/2.5V
RX_BD11	Output	Receiver video blue data 11	1.5/1.8/2.5V
RX_BD12	Output	Receiver video blue data 12	1.5/1.8/2.5V
RX_BD13	Output	Receiver video blue data 13	1.5/1.8/2.5V
RX_BD14	Output	Receiver video blue data 14	1.5/1.8/2.5V
RX_BD15	Output	Receiver video blue data 15	1.5/1.8/2.5V
RX_GD0	Output	Receiver video green data 0	1.5/1.8/2.5V
RX_GD1	Output	Receiver video green data 1	1.5/1.8/2.5V
RX_GD2	Output	Receiver video green data 2	1.5/1.8/2.5V
RX_GD3	Output	Receiver video green data 3	1.5/1.8/2.5V
RX_GD4	Output	Receiver video green data 4	1.5/1.8/2.5V
RX_GD5	Output	Receiver video green data 5	1.5/1.8/2.5V
RX_GD6	Output	Receiver video green data 6	1.5/1.8/2.5V
RX_GD7	Output	Receiver video green data 7	1.5/1.8/2.5V
RX_GD8	Output	Receiver video green data 8	1.5/1.8/2.5V
RX_GD9	Output	Receiver video green data 9	1.5/1.8/2.5V
RX_GD10	Output	Receiver video green data 10	1.5/1.8/2.5V
RX_GD11	Output	Receiver video green data 11	1.5/1.8/2.5V
RX_GD12	Output	Receiver video green data 12	1.5/1.8/2.5V
RX_GD13	Output	Receiver video green data 13	1.5/1.8/2.5V
RX_GD14	Output	Receiver video green data 14	1.5/1.8/2.5V
RX_GD15	Output	Receiver video green data 15	1.5/1.8/2.5V
RX_RD0	Output	Receiver video red data 0	1.5/1.8/2.5V
RX_RD1	Output	Receiver video red data 1	1.5/1.8/2.5V
RX_RD2	Output	Receiver video red data 2	1.5/1.8/2.5V
RX_RD3	Output	Receiver video red data 3	1.5/1.8/2.5V
RX_RD4	Output	Receiver video red data 4	1.5/1.8/2.5V
RX_RD5	Output	Receiver video red data 5	1.5/1.8/2.5V
RX_RD6	Output	Receiver video red data 6	1.5/1.8/2.5V

RX_RD7	Output	Receiver video red data 7	1.5/1.8/2.5V
RX_RD8	Output	Receiver video red data 8	1.5/1.8/2.5V
RX_RD9	Output	Receiver video red data 9	1.5/1.8/2.5V
RX_RD10	Output	Receiver video red data 10	1.5/1.8/2.5V
RX_RD11	Output	Receiver video red data 11	1.5/1.8/2.5V
RX_RD12	Output	Receiver video red data 12	1.5/1.8/2.5V
RX_RD13	Output	Receiver video red data 13	1.5/1.8/2.5V
RX_RD14	Output	Receiver video red data 14	1.5/1.8/2.5V
RX_RD15	Output	Receiver video red data 15	1.5/1.8/2.5V
RX_MCLK	Output	Receiver audio master clock	1.5/1.8/2.5V
RX_SCLK	Output	Receiver audio serial clock	1.5/1.8/2.5V
RX_AP0	Output	Receiver audio data 0	1.5/1.8/2.5V
RX_AP1	Output	Receiver audio data 1	1.5/1.8/2.5V
RX_AP2	Output	Receiver audio data 2	1.5/1.8/2.5V
RX_AP3	Output	Receiver audio data 3	1.5/1.8/2.5V
RX_AP4	Output	Receiver audio data 4	1.5/1.8/2.5V
RX_AP5	Output	Receiver audio data 5	1.5/1.8/2.5V
ADV7619_CS_N	Input	Receiver chip select, active low	1.5/1.8/2.5V
ADV7619_INT	Output	Receiver interrupt signal	1.5/1.8/2.5V
ADV7619_RESET_N	Input	Receiver reset signal, active low	1.5/1.8/2.5V
ADV7619_CSCL_F MC	Input	Receiver I2C serial clock	1.5/1.8/2.5V
ADV7619_CSDA_F MC	Input/Output	Receiver I2C serial data	1.5/1.8/2.5V
RX0_DDC_SCL	Input	Receiver EDID controller serial clock port A	1.5/1.8/2.5V
RX0_DDC_SDA	Input/Output	Receiver EDID controller serial data port A	1.5/1.8/2.5V
RX1_DDC_SCL	Input	Receiver EDID controller serial clock port B	1.5/1.8/2.5V
RX1_DDC_SDA	Input/Output	Receiver EDID controller serial data port B	1.5/1.8/2.5V

Note: The RX pixel color-bit plane is adjustable accord to the video interface data format settings,including video format and data width.

Chapter 4

Example Codes

This chapter provides NIOS based examples for users to get started using the HDMI-FMC board.

4-1 4K HDMI Loopback Demonstration

The Loopback demonstration establishes connection between the HDMI Receiver input to the transmitter output of the HDMI daughter board. The Loopback (Internal bypass) generates the HDMI video and/or audio signals, as the audio and video output pins of the receiver are directly connected to the input audio and video pins of the transmitter with a buffer and a PLL to realize the synchronous operation.

In order to receive 4K video, the HDMI RX Chip ADV7619 is configured as "2x24-bit SDR 4:4:4 interleaved Mode 0". In this case, the ADV7619 will output two pixels per video clock. A DDIO IP is used to convert two pixels to one pixel by twice the video clock. The HDMI TX Chip SiI9136-3 is configured as RGB input and RGB output mode.

A Nios II Processor is used to configure the HDMI TX and RX chips through the I2C interfaced. There are two HDMI RX ports on the board, and the Nios II processor polls the port status. Once it finds a port is plugged and detects TMSD clock input, it sets the RX port as the active port. At the same time, it configures the RX chip to measure the input video information of the active port and dump the information to the Nios II terminal. There are two EEPROMs for storing EDID content that is also programmed by the Nios II Processor.

Figure 4-1 shows the system block diagram of loopback demonstration.

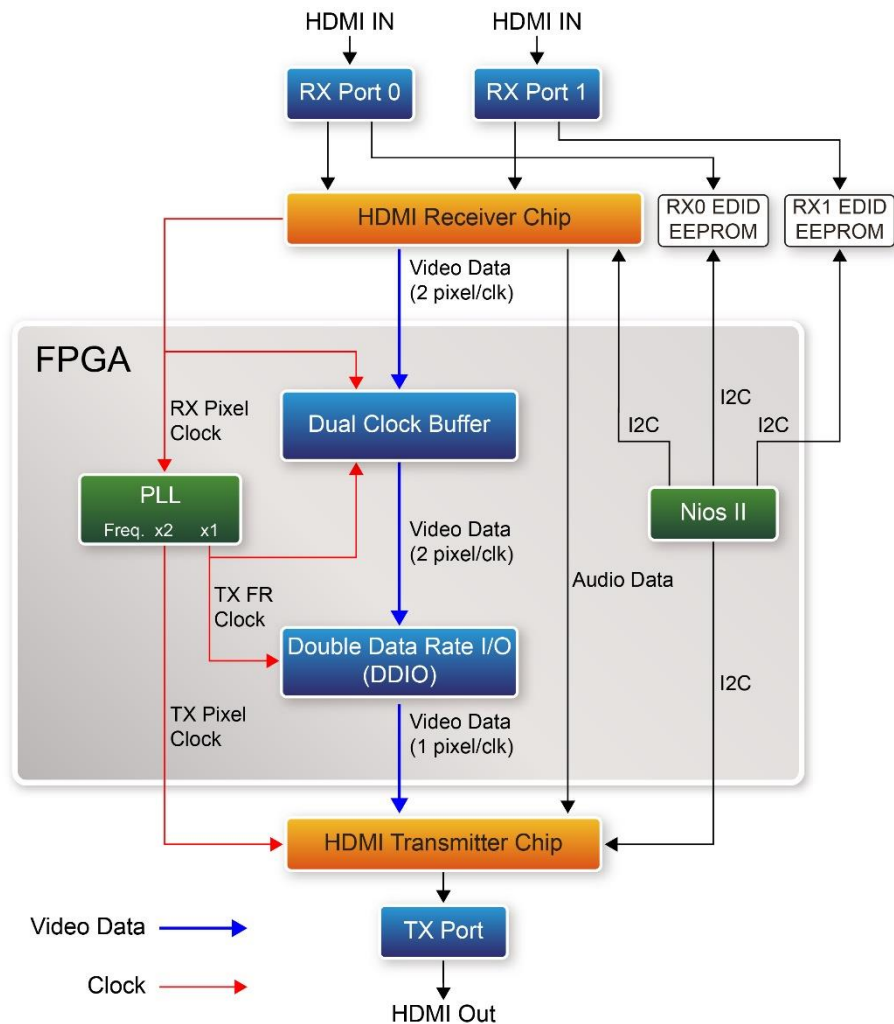

Figure 4-1 System block diagram of the HDMI loopback demonstration

■ HAN Loopback Demonstration Setup

Figure 4-2 shows the hardware setup of loopback demonstration for Terasic HAN Pilot Platform.

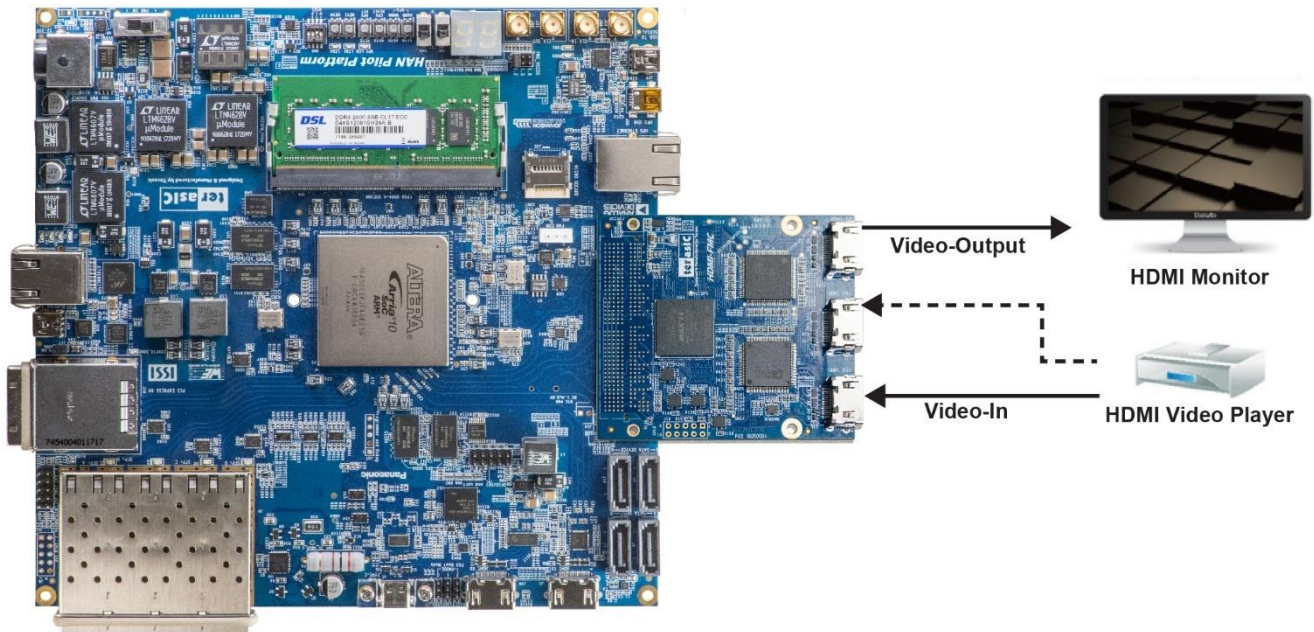

Figure 4-2 Hardware setup of HDMI loopback demonstration for HAN

■ System Requirements

The following items are required for HAN Loopback demonstration:

- HDMI-FMC board x1
- HAN Pilot Platform x1
- 4K HDMI monitor
- 4K HDMI Source Device x1
- HDMI Cable x2

■ Operation

Please follow the steps below to set up the hardware and configure the FPGA.

1. Make sure Quartus Standard 18.1 or later version has been installed on your PC.
2. Set FMC VADJ as 1.8V by shorting pin 5&pin 6 of JP2 on the HAN Pilot Platform.
3. Connect the FMC-HDMI daughter board to HAN board via FMC connector and make sure the screws on the HDMI-FMC card have been tightened firmly.
4. Connect the 4K HDMI monitor and the HDMI TX port with a HDMI cable, power on the monitor and make sure the monitor is set to HDMI input mode.
5. Connect the 4K HDMI source device (such as HDMI video player) and HDMI RX port (HDMI RX0 or HDMI RX1 port) on the FMC-HDMI board with a HDMI cable, power on the HDMI source device and make sure its HDMI port is selected as the output.
6. Connect PC with Han board Han USB-Blaster II port via a mini USB cable.

7. Power on Han board.
8. Execute the batch file test.bat under the folder “\HAN_HDMI_FMC\demo_batch”.

Note: Do not attempt to connect/remove the HDMI-FMC daughter board to/from the main board when the power is on, or the hardware could be damaged.

■ TR5 Loopback Demonstration Setup

Figure 4-3 shows the hardware setup of loopback demonstration for Terasic TR5 FPGA Mainboard.

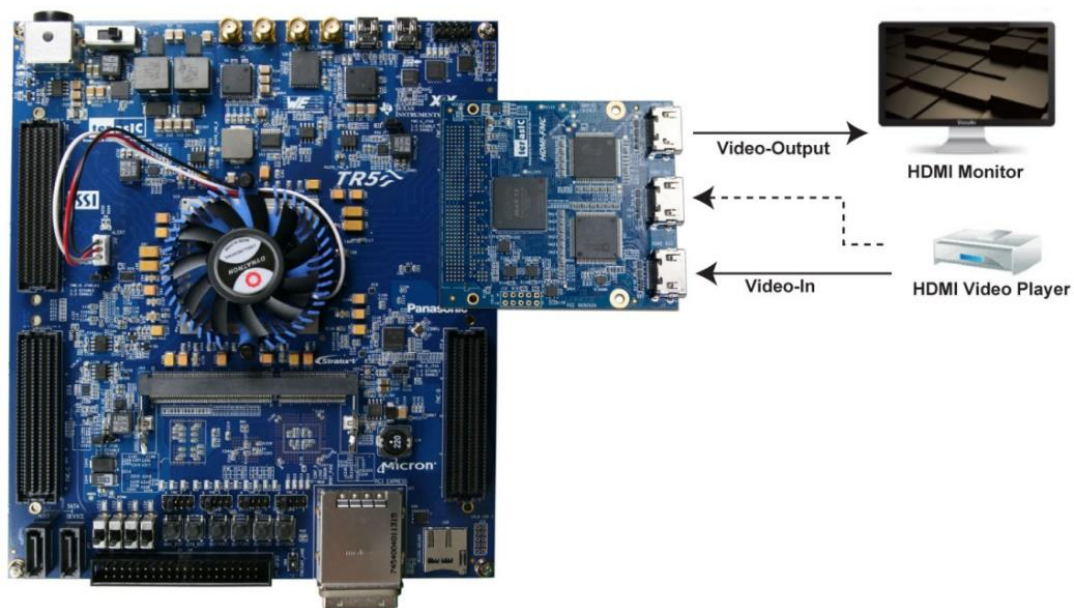

Figure 4-3 Hardware setup of HDMI loopback demonstration for TR5

■ System Requirements

The following items are required for TR5 Loopback demonstration:

- HDMI-FMC board x1
- TR5 board x1
- 4K HDMI monitor
- 4K HDMI Source Device x1
- HDMI Cable x2

■ Operation

Please follow the steps below to set up the hardware and configure the FPGA.

1. Make sure Quartus 16.1 or later version has been installed on your PC.

2. The TR5 FMC A connector I/O standard should be set to the same as HDMI-FMC card 2.5V I/O standard. Short Pin 7 & 8 of JP5 header on TR5 board to set the FMC A connector VCCIO Voltage to 2.5V (User can refer to section 2.2 of TR5 User Manual for detail).
3. Connect the FMC-HDMI daughter board to TR5 board via FMC A connector and make sure the screws on the HDMI-FMC card have been tightened firmly.
4. Connect the 4K HDMI monitor and the HDMI TX port with a HDMI cable, power on the monitor and make sure the monitor is set to HDMI input mode.
5. Connect the 4K HDMI source device (such as HDMI video player) and HDMI RX port (HDMI RX0 or HDMI RX1 port) on the FMC-HDMI board with a HDMI cable, power on the HDMI source device and make sure its HDMI port is selected as the output.
6. Connect PC with TR5 board TR5 USB-Blaster II port via a mini USB cable.
7. Power on TR5 board.
8. Execute the batch file test.bat under the folder “\TR5_HDMI_FMC\demo_batch”.

Note: Do not attempt to connect/remove the HDMI-FMC daughter board to/from the main board when the power is on, or the hardware could be damaged.

■ A10SoC Loopback Demonstration Setup

Figure 4-4 shows the hardware setup of loopback demonstration for Intel A10SoC FPGA Mainboard.

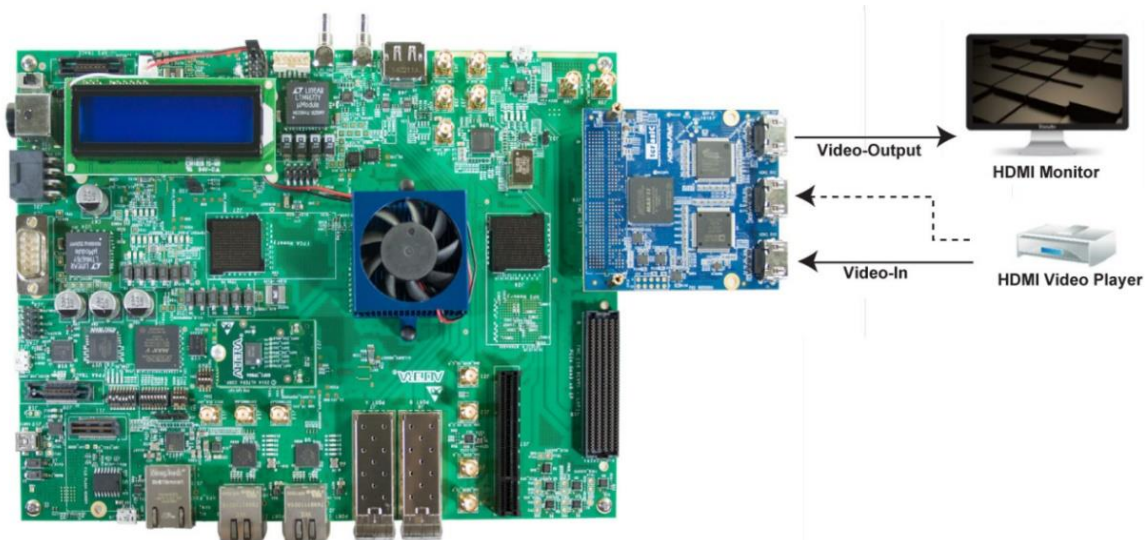

Figure 4-4 Hardware setup of HDMI loopback demonstration for A10SoC

■ System Requirements

The following items are required for A10SoC Loopback demonstration:

- HDMI-FMC board x1
- A10SoC Production Edition board (with 10AS066N3F40E2SG device) x1
- 4K HDMI monitor
- 4K HDMI Source Device x1
- HDMI Cable x2

■ Operation

1. Hardware Modification

The A10SoC board is an Intel product, the FMC definition of the Intel A10SoC board is a little different from the standard definition (our FMC definition is based on standard), so there are some reserved resistors on the Intel A10SoC Production board design for users to switch the circuit. Users need to rework three groups of resistors to make the HDMI-FMC card working on the A10SoC Production board normally.

(Note: If user's operation of modifying the resistors is unskilled or improper, it may have the risk of damaging the board hardware. So, please be careful when modifying the resistors.)

- Remove the resistors on the R612 and R613 positions in the red box, then install 0 Ohm resistors on the R610 and R611 positions in the green box, as shown in **Figure 4-5**.

In the default resistors setting, the TX_PCLK and SiI9136_RST_N signals are not controlled, there will be no image outputting on the monitor. After modifying this group of resistors, there will be image output.

- Remove the resistors on the R621 and R633 positions in the red box, then install 0 Ohm resistors on the R620 and R632 positions in the green box, as shown in **Figure 4-5**.

In the default resistors setting, the TX_BD4 and TX_BD10 signals are not controlled, the expected black color of the output image will display blue. After modifying this group of resistors, the black color of the output image will display normally.

- Remove the resistors on the R585 and R584 positions in the red box, then install 0 Ohm resistors on the R587 and R586 positions in the green box, as shown in **Figure 4-6**.

In the default resistors setting, the RX_RD14 and RX_RD15 signals don't input to FPGA, the red color will be not normal. After modifying this group of resistors, the red color will display normally.

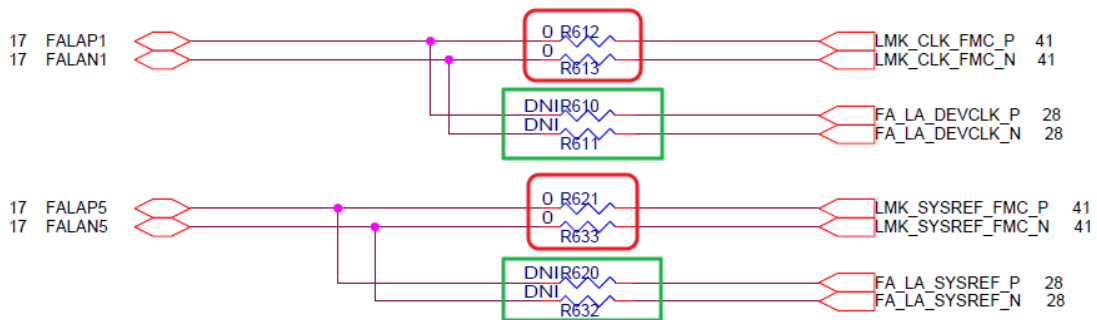

Figure 4-5 The resistors need to be reworked

Clock MUX for 3A Bank reference clock

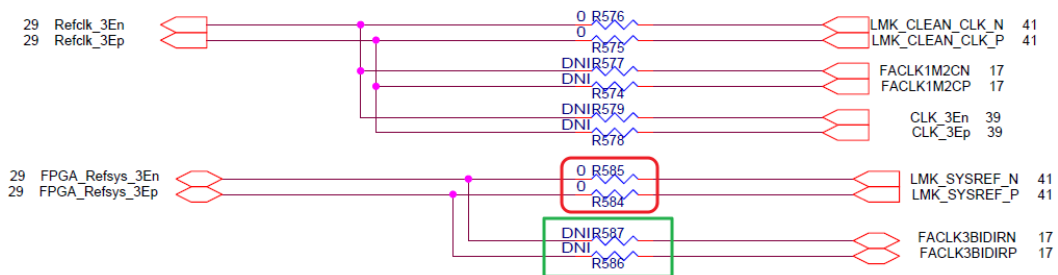

Figure 4-6 The resistors need to be reworked

Figure 4-7 shows the resistors (that need to be reworked) positions on A10SoC Production board PCB.

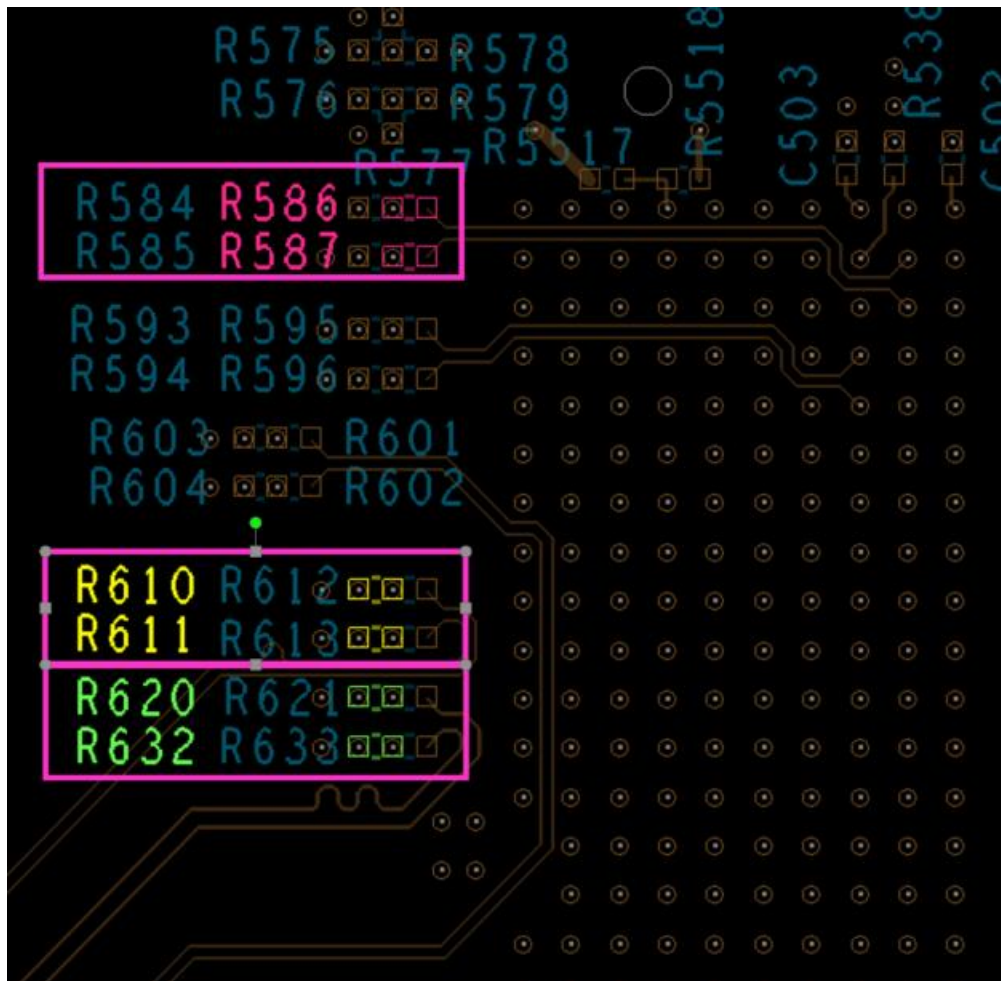

Figure 4-7 The resistors positions on the PCB

2. Make sure Quartus 18.1 or later version has been installed on your PC.
3. Program the max5.pof code into A10SoC I/O MAX V as the steps below:
 - Set the switches of the SW3 as shown in the **Figure 4-8** first.

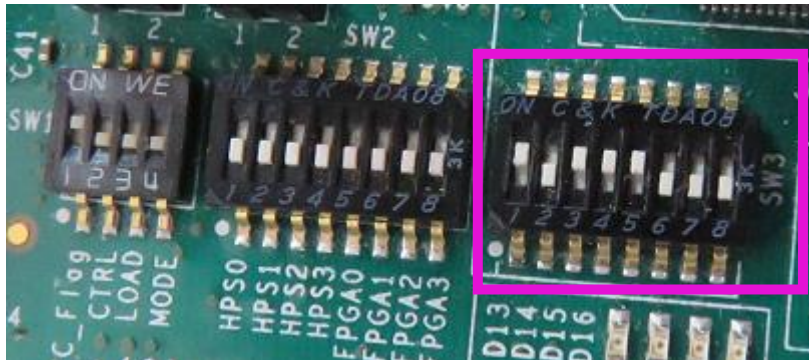

Figure 4-8 SW3 setting

- Connect the PC with A10SoC USB-Blaster II connector via USB cable. Then power on the A10SoC board, open the Quartus Programmer tool, click Auto Detect, see **Figure 4-9**.

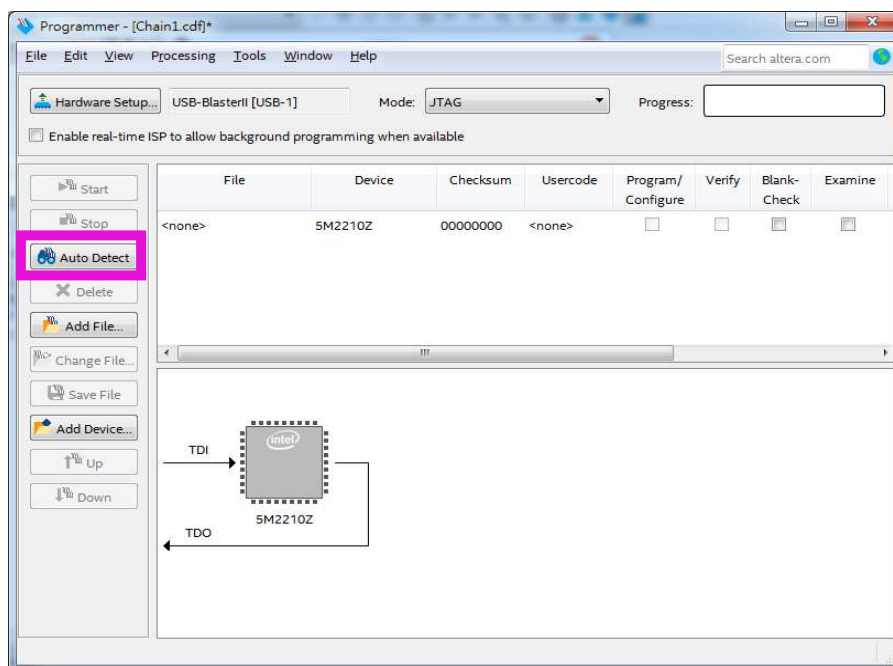

Figure 4-9 Quartus Programmer windows

- Select the max5.pof file (in the ...\\A10SoC_HDMI_FMC\\demo_batch folder) into the MAX V device, see **Figure 4-10**.

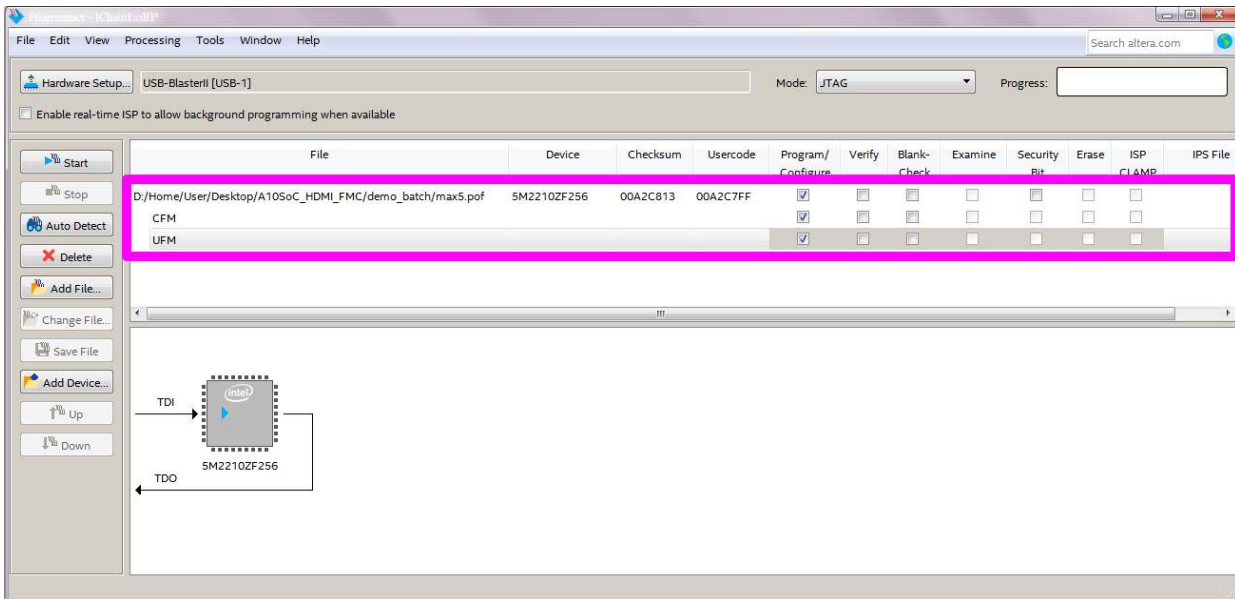

Figure 4-10 Select the max5.pof file

- Click Start button to program as shown in **Figure 4-11**.

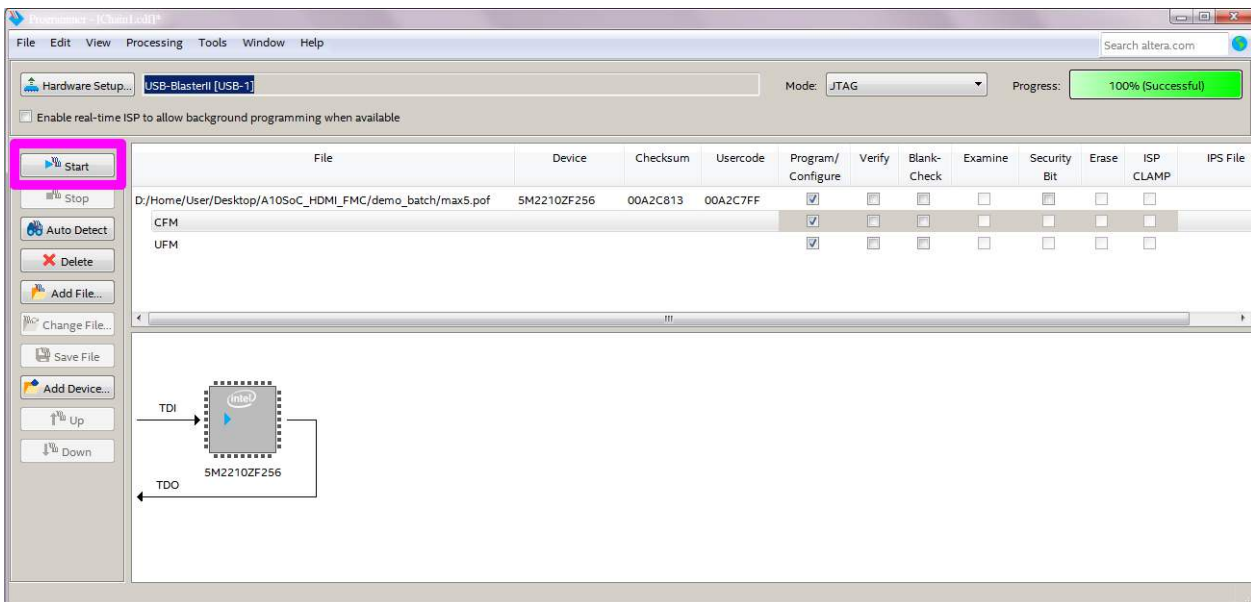

Figure 4-11 Program the max5.pof

- After programming successfully, power off the A10SoC board and set the switches of the SW3 as shown in **Figure 4-12**.

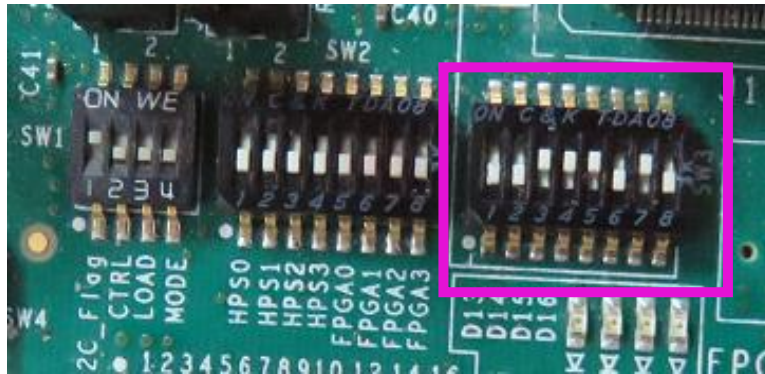

Figure 4-12 SW3 setting

4. Connect the FMC-HDMI daughter board to A10SoC board via FMCA connector and make sure the screws on the HDMI-FMC card have been tightened firmly.
5. Connect the 4K HDMI monitor and the HDMI TX port with a HDMI cable, power on the monitor and make sure the monitor is set to HDMI input mode.
6. Connect the 4K HDMI source device (such as HDMI video player) and HDMI RX port (HDMI RX0 or HDMI RX1 port) on the FMC-HDMI board with a HDMI cable, power on the HDMI source device and make sure its HDMI port is selected as the output.
7. Connect PC with A10SoC board USB-Blaster II port via a mini USB cable.
8. Power on A10SoC board.
9. Execute the batch file test.bat under the folder "...\\A10SoC_HDMI_FMC\\demo_batch".

Chapter 5

Appendix

5-1 Revision History

Version	Date	Change Log
V1.0		Initial Version
V1.1	2017/06/03	Add A10SoC Setup Figure
V1.2	2017/11/30	Modify Figure 2-3 and Figure 3-1
V1.3	2018/3/7	Add Register Tables and Demo Setup Steps
V1.4	2018/7/3	Modify steps number from 10,11,12 to 8,9,10 in Page 43, 44 and marked as red color
V1.5	2019/6/28	Modify section 4-1, add new operation step 2 for TR5 demo
V1.6	2019/08/05	Add HAN+HDMI-FMC demo, change the A10SoC ES board to A10SoC Production board
V1.7	2020/11/25	Modify FMC interface I/O Standard

5-2 Copyright Statement

Copyright © 2017 Terasic Inc. All rights reserved.