SAMA5D27 MPU, 1Gbit (128MB) DDR2 SDRAM, 10/100 Ethernet PHY, 64Mbit (8MB) Flash, Power Management IC, 1Kbit EEPROM

Introduction

The Microchip SAMA5D27 SOM1 is a small single-sided System-On-Module (SOM) based on the high-performance System-in-Package 32-bit Arm® Cortex®-A5 processor-based MPU SAMA5D27 and 1Gb DDR2 SDRAM running up to 500 MHz.

The SAMA5D27 SOM1 is built on a common set of proven Microchip components to reduce time to market by simplifying hardware design and software development.

The SOM also limits design rules of the main application board, reducing overall PCB complexity and cost. The SAMA5D27 SOM1 is delivered with a free Linux® distribution and bare metal C examples.

Figure 1. SAMA5D27 SOM1



Features

- System-In-Package (SAMA5D27C-D1G-CU) including:
 - Arm Cortex-A5 processor-based SAMA5D2 MPU
 - 1 Gbit DDR2 SDRAM
- On-Board Power Management Unit (MIC2800-G1JJYML)
- 1 Kb Serial EEPROM with EUI-48™ Node Identity (24AA02E48T-I/OT)
- 64 Mb Serial Quad I/O Flash Memory (SST26VF064BT-104I/MF)
- 10Base-T/100Base-TX Ethernet PHY (KSZ8081RNAIA)

- 40 x 38 mm Module, Pitch 0.8 mm, solderable by hand
- 103 I/Os
- Up to 7 Tamper
- One USB Device, One USB Host and One HSIC Interface
- Shutdown and Reset Control Pins
- Up to 24-bit LCD Interface
- Independent Power Supplies Available for Camera Sensor, for SD Card and for Backup depending on Voltage Domains
- Operational Specifications:
 - Main operating voltage: 3.3V \pm 5%
 - Temperature range: -40°C to 85°C
 - Integrated crystals, internal voltage regulators
 - Multiple interfaces and I/Os for easy application development

Applications

- Healthcare/Patient Monitoring
- IoT Secure Gateways
- Human Machine Interface, Control Panel
- Home and Building Automation, Thermostat, Industrial Gateways

Table of Contents

Introduction.....	1
Features.....	1
Applications.....	2
1. Description.....	5
2. Reference Documents.....	6
3. Block Diagram.....	7
4. Pinout.....	8
4.1. Pinout Overview.....	8
4.2. Pin List.....	8
5. Functional Description.....	26
5.1. SAMA5D27 System-In-Package.....	26
5.2. Power Supplies.....	27
5.3. System Control.....	28
5.4. Ethernet PHY.....	29
5.5. QSPI Memory.....	30
5.6. EEPROM Memory.....	31
6. Power Supply Connections and Timing Sequences.....	33
6.1. Power Supply Configuration #1.....	33
6.2. Power Supply Configuration #2.....	34
6.3. Power Supply Configuration #3.....	35
6.4. Power Supply Configuration #4.....	37
7. Booting Guidelines.....	39
7.1. Boot Process.....	39
7.2. Boot Configuration.....	39
7.3. NVM Programming.....	39
7.4. Boot From External Memory.....	39
8. Debug Considerations.....	41
9. Electrical Characteristics.....	42
9.1. Absolute Maximum Ratings.....	42
9.2. Operational Characteristics.....	42
9.3. DC Electrical Characteristics.....	43
10. Mechanical Characteristics.....	45
10.1. Module Dimensions.....	45
10.2. Module Land Pattern.....	46
11. Production Settings.....	48
11.1. Bake Information.....	48
11.2. Reflow Profile.....	48

12. Ordering Information.....	50
13. Revision History.....	51
The Microchip Website.....	52
Product Change Notification Service.....	52
Customer Support.....	52
Product Identification System.....	53
Microchip Devices Code Protection Feature.....	53
Legal Notice.....	53
Trademarks.....	54
Quality Management System.....	54
Worldwide Sales and Service.....	55

1. Description

The SAMA5D27 SOM1 is a high-performance System-On-Module based on the 32-bit ARM Cortex-A5 RISC SAMA5D2 processor. The SAMA5D27 SOM1 is certified for industrial operating conditions over a -40 to 85°C temperature range.

The system of the SAMA5D27 SOM1 operates at a maximum CPU operating frequency of 500 MHz and a maximum bus speed of 166 MHz. It features up to:

- 1 Gbit of DDR2 SDRAM memory (SAMA5D27C-D1G-CU)
- 1 Kb of EEPROM memory (24AA02E48T-I/OT) with EUI-48
- 64 Mb of QSPI Flash (SST26VF064BT-104I/MF) memory

The SAMA5D27 SOM1 is a 176-pin, 0.8mm pad pitch module, 40 mm x 38 mm in size.

The SAMA5D27 SOM1 offers an extensive peripheral set, including High-speed USB Host and Device, HSIC Interface, 10Base-T/100Base-TX Ethernet Interface, system control and up to 103 I/Os featuring:

- Up to 4 UARTs
- Up to 4 Flexcoms
- Up to 6 Capacitive Touch lines for up to 9 touch buttons
- Up to 10 ADC Inputs
- Up to 2 CAN
- Up to 7 Tamper Pins
- Serial Interfaces such as SPI, TWI, QSPI, SSC and I²S
- SD/MMC, eMMC, SDIO Interfaces
- Up to 24-bit LCD RGB Interface
- CMOS Camera Interface
- Mono PDMIC and Full-Bridge Class-D Stereo
- Up to 6 Capacitive Touch Lines



Tip: Each I/O of the SAMA5D27 SOM1 is configurable, as either a general-purpose I/O line only, or as an I/O line multiplexed with up to six peripheral I/Os. As the multiplexing is hardware-defined, the hardware designer and programmer must carefully determine the configuration of the PIO Controllers required by their application.

2. Reference Documents

The SAMA5D27 SOM1 is equipped with various Microchip silicon devices. The relevant documentation is listed in the table below.

Type	Document Title	Available	Ref. No./Product
Data sheet	SAMA5D2	www.microchip.com/SAMA5D2	DS60001476
Data sheet	SAMA5D2 System-In-Package (SIP)	www.microchip.com/SAMA5D2 SIP	DS60001484
Data sheet	Serial EEPROMs with EUI-48 Node Identity	www.microchip.com/24AA02E48	24AA02E48T-I/OT
Data sheet	10BASE-T/100BASE-TX Ethernet PHY	www.microchip.com/ksz8081	KSZ8081RNAIA
Data sheet	Serial Quad I/O (SQI) Flash Memory	www.microchip.com/sst26vf064b	SST26VF064BT-104I/MF
Data sheet	Digital Power Management IC	www.microchip.com/mic2800	MIC2800-G1JJYML

3. Block Diagram

Figure 3-1. SAMA5D27 SOM1 Block Diagram

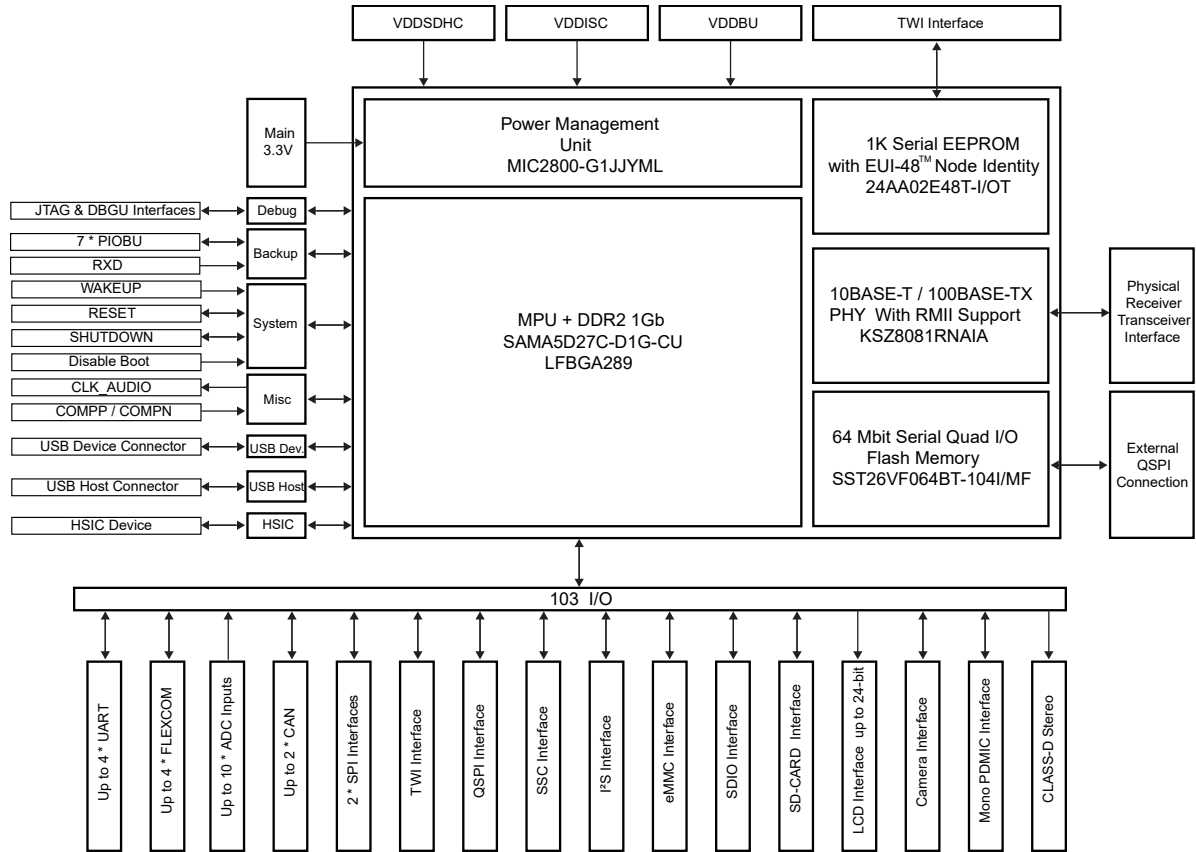

4. Pinout

4.1 Pinout Overview

The categories of pins are listed below:

- Red: Power Supplies
- Black: Ground
- Blue: Signals
- Orange: Reserved for future use

Figure 4-1. SAMA5D27 SOM1 Pinout Overview

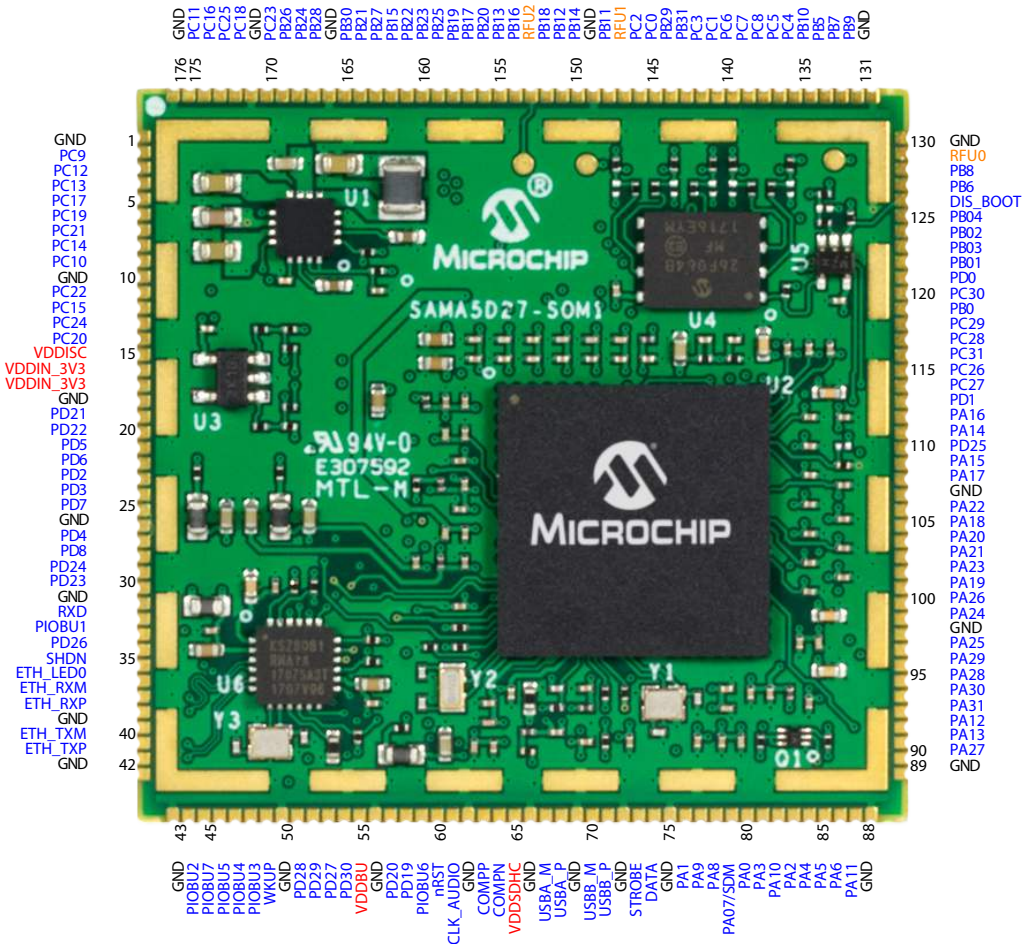

4.2 Pin List

The pin list of the SAMA5D27 SOM1 is provided in the following tables.



Important: Compared to SAMA5D2 Series devices, some PIO features are not listed. These features are used internally on the SOM and cannot be shared with other PIOs for purposes of features or signal integrity.

4.2.1 PIOA Pin Description

Table 4-1. System-On-Module Pin Description: PIOA

Pad No.	Power Rail	I/O Type	Primary		Alternate		PIO Peripheral				Reset State (Signal, Dir, PU, PD, HiZ, ST)
			Signal	Dir	Signal	Dir	Func	Signal	Dir	IO Set	
80	VDDSDHC	GPIO_EMMC	PA0	I/O	-	-	A	SDMMC0_CK	I/O	1	PIO, I, PU, ST
							B	QSPIO_SCK	O	1	
							F	D0	I/O	2	
76	VDDSDHC	GPIO_EMMC	PA1	I/O	-	-	A	SDMMC0_CMD	I/O	1	PIO, I, PU, ST
							B	QSPIO_CS	O	1	
							F	D1	I/O	2	
83	VDDSDHC	GPIO_EMMC	PA2	I/O	-	-	A	SDMMC0_DAT0	I/O	1	PIO, I, PU, ST
							B	QSPIO_IO0	I/O	1	
							F	D2	I/O	2	
81	VDDSDHC	GPIO_EMMC	PA3	I/O	-	-	A	SDMMC0_DAT1	I/O	1	PIO, I, PU, ST
							B	QSPIO_IO1	I/O	1	
							F	D3	I/O	2	
84	VDDSDHC	GPIO_EMMC	PA4	I/O	-	-	A	SDMMC0_DAT2	I/O	1	PIO, I, PU, ST
							B	QSPIO_IO2	I/O	1	
							F	D4	I/O	2	
85	VDDSDHC	GPIO_EMMC	PA5	I/O	-	-	A	SDMMC0_DAT3	I/O	1	PIO, I, PU, ST
							B	QSPIO_IO3	I/O	1	
							F	D5	I/O	2	
86 ⁽²⁾	VDDSDHC	GPIO_EMMC	PA6	I/O	-	-	A	SDMMC0_DAT4	I/O	1	PIO, I, PU, ST
							D	TIOA5	I/O	1	
							E	FLEXCOM2_IO0	I/O	1	
							F	D6	I/O	2	
79 ⁽²⁾	VDDSDHC	GPIO_EMMC	PA7	I/O	-	-	A	SDMMC0_DAT5	I/O	1	PIO, I, PU, ST
							D	TIOB5	I/O	1	
							E	FLEXCOM2_IO1	I/O	1	
							F	D7	I/O	2	
78 ⁽²⁾	VDDSDHC	GPIO_EMMC	PA8	I/O	-	-	A	SDMMC0_DAT6	I/O	1	PIO, I, PU, ST
							D	TCLK5	I	1	
							E	FLEXCOM2_IO2	I/O	1	
							F	NWE/NANDWE	O	2	

SAMA5D27 SOM1

Pinout

.....continued

Pad No.	Power Rail	I/O Type	Primary		Alternate		PIO Peripheral				Reset State (Signal, Dir, PU, PD, HiZ, ST)
			Signal	Dir	Signal	Dir	Func	Signal	Dir	IO Set	
77(2)	VDDSDHC	GPIO_EMMC	PA9	I/O	-	-	A	SDMMC0_DAT7	I/O	1	PIO, I, PU, ST
							D	TIOA4	I/O	1	
							E	FLEXCOM2_IO3	O	1	
							F	NCS3	O	2	
82(2)	VDDSDHC	GPIO_EMMC	PA10	I/O	-	-	A	SDMMC0_RSTN	O	1	PIO, I, PU, ST
							D	TIOB4	I/O	1	
							E	FLEXCOM2_IO4	O	1	
							F	A21/NANDALE	O	2	
87(2)	VDDIN_3V3	GPIO	PA11	I/O	-	-	A	SDMMC0_VDDSEL	O	1	PIO, I, PU, ST
							D	TCLK4	I	1	
							F	A22/NANDCLE	O	2	
92	VDDIN_3V3	GPIO	PA12	I/O	-	-	A	SDMMC0_WP	I	1	PIO, I, PU, ST
							B	IRQ	I	1	
							F	NRD/NANDOE	O	2	
91	VDDIN_3V3	GPIO	PA13	I/O	-	-	A	SDMMC0_CD	I	1	PIO, I, PU, ST
							E	FLEXCOM3_IO1	I/O	1	
							F	D8	I/O	2	
111	VDDIN_3V3	GPIO_QSPI	PA14	I/O	-	-	A	SPI0_SPCK	I/O	1	PIO, I, PU, ST
							B	TK1	I/O	1	
							C	QSPI0_SCK	O	2	
							D	I2SMCK1	O	2	
							E	FLEXCOM3_IO2	I/O	1	
							F	D9	I/O	2	
109	VDDIN_3V3	GPIO	PA15	I/O	-	-	A	SPI0_MOSI	I/O	1	PIO, I, PU, ST
							B	TF1	I/O	1	
							C	QSPI0_CS	O	2	
							D	I2SCK1	I/O	2	
							E	FLEXCOM3_IO0	I/O	1	
							F	D10	I/O	2	
112	VDDIN_3V3	GPIO_IO	PA16	I/O	-	-	A	SPI0_MISO	I/O	1	PIO, I, PU, ST
							B	TD1	O	1	
							C	QSPI0_IO0	I/O	2	
							D	I2SWS1	I/O	2	
							E	FLEXCOM3_IO3	O	1	
							F	D11	I/O	2	

SAMA5D27 SOM1

Pinout

.....continued

Pad No.	Power Rail	I/O Type	Primary		Alternate		PIO Peripheral				Reset State (Signal, Dir, PU, PD, HiZ, ST)
			Signal	Dir	Signal	Dir	Func	Signal	Dir	IO Set	
108	VDDIN_3V3	GPIO_IO	PA17	I/O	-	-	A	SPI0_NPCS0	I/O	1	PIO, I, PU, ST
							B	RD1	I	1	
							C	QSPI0_IO1	I/O	2	
							D	I2SDI1	I	2	
							E	FLEXCOM3_IO4	O	1	
							F	D12	I/O	2	
105	VDDIN_3V3	GPIO_IO	PA18	I/O	-	-	A	SPI0_NPCS1	O	1	PIO, I, PU, ST
							B	RK1	I/O	1	
							C	QSPI0_IO2	I/O	2	
							D	I2SDO1	O	2	
							E	SDMMC1_DAT0	I/O	1	
							F	D13	I/O	2	
101	VDDIN_3V3	GPIO_IO	PA19	I/O	-	-	A	SPI0_NPCS2	O	1	PIO, I, PU, ST
							B	RF1	I/O	1	
							C	QSPI0_IO3	I/O	2	
							D	TIOA0	I/O	1	
							E	SDMMC1_DAT1	I/O	1	
							F	D14	I/O	2	
104	VDDIN_3V3	GPIO_IO	PA20	I/O	-	-	A	SPI0_NPCS3	O	1	PIO, I, PU, ST
							D	TIOB0	I/O	1	
							E	SDMMC1_DAT2	I/O	1	
							F	D15	I/O	2	
103	VDDIN_3V3	GPIO_IO	PA21	I/O	-	-	A	IRQ	I	2	PIO, I, PU, ST
							B	PCK2	O	3	
							D	TCLK0	O	1	
							E	SDMMC1_DAT3	I/O	1	
							F	NANDRDY	I	2	
106	VDDIN_3V3	GPIO_QSPI	PA22	I/O	-	-	A	FLEXCOM1_IO2	I/O	1	PIO, I, PU, ST
							B	D0	I/O	1	
							C	TCK	I	4	
							D	SPI1_SPCK	I/O	2	
							E	SDMMC1_CK	I/O	1	
							F	QSPI0_SCK	O	3	

SAMA5D27 SOM1

Pinout

.....continued

Pad No.	Power Rail	I/O Type	Primary		Alternate		PIO Peripheral				Reset State (Signal, Dir, PU, PD, HiZ, ST)
			Signal	Dir	Signal	Dir	Func	Signal	Dir	IO Set	
102	VDDIN_3V3	GPIO	PA23	I/O	-	-	A	FLEXCOM1_IO1	I/O	1	PIO, I, PU, ST
							B	D1	I/O	1	
							C	TDI	I	4	
							D	SPI1_MOSI	I/O	2	
							F	QSPI0_CS	O	3	
99	VDDIN_3V3	GPIO_IO	PA24	I/O	-	-	A	FLEXCOM1_IO0	I/O	1	PIO, I, PU, ST
							B	D2	I/O	1	
							C	TDO	O	4	
							D	SPI1_MISO	I/O	2	
							F	QSPI0_IO0	I/O	3	
97	VDDIN_3V3	GPIO_IO	PA25	I/O	-	-	A	FLEXCOM1_IO3	O	1	PIO, I, PU, ST
							B	D3	I/O	1	
							C	TMS	I	4	
							D	SPI1_NPCS0	I/O	2	
							F	QSPI0_IO1	I/O	3	
100	VDDIN_3V3	GPIO_IO	PA26	I/O	-	-	A	FLEXCOM1_IO4	O	1	PIO, I, PU, ST
							B	D4	I/O	1	
							C	NTRST	I	4	
							D	SPI1_NPCS1	O	2	
							F	QSPI0_IO2	I/O	3	
90	VDDIN_3V3	GPIO_IO	PA27	I/O	-	-	A	TIOA1	I/O	2	PIO, I, PU, ST
							B	D5	I/O	1	
							C	SPI0_NPCS2	O	2	
							D	SPI1_NPCS2	O	2	
							E	SDMMC1_RSTN	O	1	
							F	QSPI0_IO3	I/O	3	
95	VDDIN_3V3	GPIO	PA28	I/O	-	-	A	TIOB1	I/O	2	PIO, I, PU, ST
							B	D6	I/O	1	
							C	SPI0_NPCS3	O	2	
							D	SPI1_NPCS3	O	2	
							E	SDMMC1_CMD	I/O	1	
							F	CLASSD_L0	O	1	

SAMA5D27 SOM1

Pinout

.....continued

Pad No.	Power Rail	I/O Type	Primary		Alternate		PIO Peripheral				Reset State (Signal, Dir, PU, PD, HiZ, ST)
			Signal	Dir	Signal	Dir	Func	Signal	Dir	IO Set	
96	VDDIN_3V3	GPIO	PA29	I/O	-	-	A	TCLK1	I	2	PIO, I, PU, ST
							B	D7	I/O	1	
							C	SPI0_NPCS1	O	2	
							E	SDMMC1_WP	I	1	
							F	CLASSD_L1	O	1	
94	VDDIN_3V3	GPIO	PA30	I/O	-	-	B	NWE / NANDWE	O	1	PIO, I, PU, ST
							C	SPI0_NPCS0	I/O	2	
							D	PWMH0	O	1	
							E	SDMMC1_CD	I	1	
							F	CLASSD_L2	O	1	
93	VDDIN_3V3	GPIO	PA31	I/O	-	-	B	NCS3	O	1	PIO, I, PU, ST
							C	SPI0_MISO	I/O	2	
							D	PWML0	O	1	
							F	CLASSD_L3	O	1	

Notes:

1. Fixed feature due to the SOM internal connection.
2. Limited feature compared to SAMA5D2 due to the SOM internal use of specific functionality, for example, QSPI, GMAC.
3. Limited feature compared to SAMA5D2 due to the use of a part of the functionality for other features in the SOM, for example, GMAC, ISC, Flexcom, etc.

4.2.2 PIOB Pin Description

Table 4-2. System-On-Module Pin Description: PIOB

Pad No.	Power Rail	I/O Type	Primary		Alternate		PIO Peripheral				Reset State (Signal, Dir, PU, PD, HiZ, ST)
			Signal	Dir	Signal	Dir	Func	Signal	Dir	IO Set	
119	VDDIN_3V3	GPIO	PB0	I/O	-	-	B	A21 / NANDALE	O	1	PIO, I, PU, ST
							C	SPI0_MOSI	I/O	2	
							D	PWMH1	O	1	
122	VDDIN_3V3	GPIO	PB1	I/O	-	-	B	A22 / NANDCLE	O	1	PIO, I, PU, ST
							C	SPI0_SPCK	I/O	2	
							D	PWML1	O	1	
							F	CLASSD_R0	O	1	
124	VDDIN_3V3	GPIO	PB2	I/O	-	-	B	NRD/NANDOE	O	1	PIO, I, PU, ST
							D	PWMFIO	I	1	
							F	CLASSD_R1	O	1	

SAMA5D27 SOM1

Pinout

.....continued

Pad No.	Power Rail	I/O Type	Primary		Alternate		PIO Peripheral				Reset State (Signal, Dir, PU, PD, HiZ, ST)
			Signal	Dir	Signal	Dir	Func	Signal	Dir	IO Set	
123	VDDIN_3V3	GPIO	PB3	I/O	-	-	A	URXD4	I	1	PIO, I, PU, ST
							B	D8	I/O	1	
							C	IRQ	I	3	
							D	PWMEXTRG0	I	1	
							F	CLASSD_R2	O	1	
125	VDDIN_3V3	GPIO	PB4	I/O	-	-	A	UTXD4	O	1	PIO, I, PU, ST
							B	D9	I/O	1	
							C	FIQ	I	4	
							F	CLASSD_R3	O	1	
134 ⁽²⁾	VDDIN_3V3	GPIO_QSPI	PB5	I/O	-	-	A	TCLK2	I	1	PIO, I, PU, ST
							C	PWMH2	O	1	
							D	QSPI1_SCK	O	2	
127 ⁽²⁾	VDDIN_3V3	GPIO	PB6	I/O	-	-	A	TIOA2	I/O	1	PIO, I, PU, ST
							C	PWML2	O	1	
							D	QSPI1_CS	O	2	
133 ⁽²⁾	VDDIN_3V3	GPIO_IO	PB7	I/O	-	-	A	TIOB2	I/O	1	PIO, I, PU, ST
							C	PWMH3	O	1	
							D	QSPI1_IO0	I/O	2	
128 ⁽²⁾	VDDIN_3V3	GPIO_IO	PB8	I/O	-	-	A	TCLK3	I	1	PIO, I, PU, ST
							C	PWML3	O	1	
							D	QSPI1_IO1	I/O	2	
132 ⁽²⁾	VDDIN_3V3	GPIO_IO	PB9	I/O	-	-	A	TIOA3	I/O	1	PIO, I, PU, ST
							C	PWMF1	I	1	
							D	QSPI1_IO2	I/O	2	
135 ⁽²⁾	VDDIN_3V3	GPIO_IO	PB10	I/O	-	-	A	TIOB3	I/O	1	PIO, I, PU, ST
							C	PWMEXTRG1	I	1	
							D	QSPI1_IO3	I/O	2	
148 ⁽³⁾	VDDIN_3V3	GPIO	PB11	I/O	-	-	A	LCDDAT0	O	1	PIO, I, PU, ST
							B	A0/NBS0	O	1	
							C	URXD3	I	3	
							D	PDMDAT0	I/O	2	
151 ⁽³⁾	VDDIN_3V3	GPIO	PB12	I/O	-	-	A	LCDDAT1	O	1	PIO, I, PU, ST
							B	A1	O	1	
							C	UTXD3	O	3	
							D	PDMCLK0	O	2	

SAMA5D27 SOM1

Pinout

.....continued

Pad No.	Power Rail	I/O Type	Primary		Alternate		PIO Peripheral				Reset State (Signal, Dir, PU, PD, HiZ, ST)
			Signal	Dir	Signal	Dir	Func	Signal	Dir	IO Set	
155 ⁽³⁾	VDDIN_3V3	GPIO	PB13	I/O	-	-	A	LCDDAT2	O	1	PIO, I, PU, ST
							B	A2	O	1	
							C	PCK1	I/O	3	
150 ^{(2), (3)}	VDDIN_3V3	GPIO_QSPI	PB14	I/O	-	-	A	LCDDAT3	O	1	PIO, I, PU, ST
							B	A3	O	1	
							C	TK1	I/O	2	
							D	I2SMCK1	O	1	
162 ^{(2), (3)}	VDDIN_3V3	GPIO	PB15	I/O	-	-	A	LCDDAT4	O	1	PIO, I, PU, ST
							B	A4	O	1	
							C	TF1	I/O	2	
							D	I2SCK1	I/O	1	
154 ^{(2), (3)}	VDDIN_3V3	GPIO_IO	PB16	I/O	-	-	A	LCDDAT5	O	1	PIO, I, PU, ST
							B	A5	O	1	
							C	TD1	O	2	
							D	I2SWS1	I/O	1	
157 ^{(2), (3)}	VDDIN_3V3	GPIO_IO	PB17	I/O	-	-	A	LCDDAT6	O	1	PIO, I, PU, ST
							B	A6	O	1	
							C	RD1	I	2	
							D	I2SDI1	I	1	
152 ^{(2), (3)}	VDDIN_3V3	GPIO_IO	PB18	I/O	-	-	A	LCDDAT7	O	1	PIO, I, PU, ST
							B	A7	O	1	
							C	RK1	I/O	2	
							D	I2SDO1	O	1	
158 ^{(2), (3)}	VDDIN_3V3	GPIO_IO	PB19	I/O	-	-	A	LCDDAT8	O	1	PIO, I, PU, ST
							B	A8	O	1	
							C	RF1	I/O	2	
							D	TIOA3	I/O	2	
156 ⁽³⁾	VDDIN_3V3	GPIO	PB20	I/O	-	-	A	LCDDAT9	O	1	PIO, I, PU, ST
							B	A9	O	1	
							C	TK0	I/O	1	
							D	TIOB3	I/O	2	
							E	PCK1	O	4	

SAMA5D27 SOM1

Pinout

.....continued

Pad No.	Power Rail	I/O Type	Primary		Alternate		PIO Peripheral				Reset State (Signal, Dir, PU, PD, HiZ, ST)
			Signal	Dir	Signal	Dir	Func	Signal	Dir	IO Set	
164 ⁽³⁾	VDDIN_3V3	GPIO	PB21	I/O	-	-	A	LCDDAT10	O	1	PIO, I, PU, ST
							B	A10	O	1	
							C	TF0	I/O	1	
							D	TCLK3	I	2	
							E	FLEXCOM3_IO2	I/O	3	
161 ⁽³⁾	VDDIN_3V3	GPIO	PB22	I/O	-	-	A	LCDDAT11	O	1	PIO, I, PU, ST
							B	A11	O	1	
							C	TD0	O	1	
							D	TIOA2	I/O	2	
							E	FLEXCOM3_IO1	I/O	3	
160 ⁽³⁾	VDDIN_3V3	GPIO	PB23	I/O	-	-	A	LCDDAT12	O	1	PIO, I, PU, ST
							B	A12	O	1	
							C	RD0	I	1	
							D	TIOB2	I/O	2	
							E	FLEXCOM3_IO0	I/O	3	
168	VDDIN_3V3	GPIO	PB24	I/O	-	-	A	LCDDAT13	O	1	PIO, I, PU, ST
							B	A13	O	1	
							C	RK0	I/O	1	
							D	TCLK2	I	2	
							E	FLEXCOM3_IO3	O	3	
							F	ISI_D10	I	3	
159	VDDIN_3V3	GPIO	PB25	I/O	-	-	A	LCDDAT14	O	1	PIO, I, PU, ST
							B	A14	O	1	
							C	RF0	I/O	1	
							E	FLEXCOM3_IO4	O	3	
							F	ISI_D11	I	3	
169	VDDIN_3V3	GPIO	PB26	I/O	-	-	A	LCDDAT15	O	1	PIO, I, PU, ST
							B	A15	O	1	
							C	URXD0	I	1	
							D	PDMDAT0	I/O	1	
							F	ISI_D0	I	3	

SAMA5D27 SOM1

Pinout

.....continued

Pad No.	Power Rail	I/O Type	Primary		Alternate		PIO Peripheral				Reset State (Signal, Dir, PU, PD, HiZ, ST)
			Signal	Dir	Signal	Dir	Func	Signal	Dir	IO Set	
163	VDDIN_3V3	GPIO	PB27	I/O	-	-	A	LCDDAT16	O	1	PIO, I, PU, ST
							B	A16	O	1	
							C	UTXD0	O	1	
							D	PDMCLK0	O	1	
							F	ISI_D1	I	3	
167	VDDIN_3V3	GPIO	PB28	I/O	-	-	A	LCDDAT17	O	1	PIO, I, PU, ST
							B	A17	O	1	
							C	FLEXCOM0_IO0	I/O	1	
							D	TIOA5	I/O	2	
							F	ISI_D2	I	3	
144	VDDIN_3V3	GPIO	PB29	I/O	-	-	A	LCDDAT18	O	1	PIO, I, PU, ST
							B	A18	O	1	
							C	FLEXCOM0_IO1	I/O	1	
							D	TIOB5	I/O	2	
							F	ISI_D3	I	3	
165	VDDIN_3V3	GPIO	PB30	I/O	-	-	A	LCDDAT19	O	1	PIO, I, PU, ST
							B	A19	O	1	
							C	FLEXCOM0_IO2	I/O	1	
							D	TCLK5	I	2	
							F	ISI_D4	I	3	
143 ⁽²⁾	VDDIN_3V3	GPIO	PB31	I/O	-	-	A	LCDDAT20	O	1	PIO, I, PU, ST
							B	A20	O	1	
							C	FLEXCOM0_IO3	O	1	
							F	ISI_D5	I	3	

Notes:

1. Fixed feature due to the SOM internal connection.
2. Limited feature compared to SAMA5D2 due to the SOM internal use of specific functionality, for example, QSPI, GMAC.
3. Limited feature compared to SAMA5D2 due to the use of a part of the functionality for other features in the SOM, for example, GMAC, ISC, Flexcom, etc.

4.2.3 PIOC Pin Description

Table 4-3. System-On-Module Pin Description: PIOC

Pad No.	Power Rail	I/O Type	Primary		Alternate		PIO Peripheral				Reset State (Signal, Dir, PU, PD, HiZ, ST)
			Signal	Dir	Signal	Dir	Func	Signal	Dir	IO Set	
145 ⁽²⁾	VDDIN_3V3	GPIO	PC0	I/O	-	-	A	LCDDAT21	O	1	PIO, I, PU, ST
							B	A23	O	1	
							C	FLEXCOM0_IO4	O	1	
							F	ISI_D6	I	3	
141	VDDIN_3V3	GPIO	PC1	I/O	-	-	A	LCDDAT22	O	1	PIO, I, PU, ST
							B	A24	O	1	
							C	CANTX0	O	1	
							D	SPI1_SPCK	I/O	1	
							E	I2SCK0	I/O	1	
							F	ISI_D7	I	3	
146	VDDIN_3V3	GPIO	PC2	I/O	-	-	A	LCDDAT23	O	1	PIO, I, PU, ST
							B	A25	O	1	
							C	CANRX0	I/O	1	
							D	SPI1_MOSI	I/O	1	
							E	I2SMCK0	O	1	
							F	ISI_D8	I	3	
142	VDDIN_3V3	GPIO	PC3	I/O	-	-	A	LCDPWM	O	1	PIO, I, PU, ST
							B	NWAIT	I	1	
							C	TIOA1	I/O	1	
							D	SPI1_MISO	I/O	1	
							E	I2SWS0	I/O	1	
							F	ISI_D9	I	3	
136	VDDIN_3V3	GPIO	PC4	I/O	-	-	A	LCDDISP	O	1	PIO, I, PU, ST
							B	NWR1/NBS1	O	1	
							C	TIOB1	I/O	1	
							D	SPI1_NPCS0	I/O	1	
							E	I2SDI0	I	1	
							F	ISI_PCK	I	3	
137	VDDIN_3V3	GPIO	PC5	I/O	-	-	A	LCDVSYNC	O	1	PIO, I, PU, ST
							B	NCS0	O	1	
							C	TCLK1	I	1	
							D	SPI1_NPCS1	O	1	
							E	I2SDO0	O	1	
							F	ISI_VSYNC	I	3	

SAMA5D27 SOM1

Pinout

.....continued

Pad No.	Power Rail	I/O Type	Primary		Alternate		PIO Peripheral				Reset State (Signal, Dir, PU, PD, HIZ, ST)
			Signal	Dir	Signal	Dir	Func	Signal	Dir	IO Set	
140	VDDIN_3V3	GPIO	PC6	I/O	-	-	A	LCDHSYNC	O	1	PIO, I, PU, ST
							B	NCS1	O	1	
							C	TWD1	I/O	1	
							D	SPI1_NPCS2	O	1	
							F	ISI_HSYNC	I	3	
139	VDDIN_3V3	GPIO_CLK	PC7	I/O	-	-	A	LCDPCK	O	1	PIO, I, PU, ST
							B	NCS2	O	1	
							C	TWCK1	I/O	1	
							D	SPI1_NPCS3	O	1	
							E	URXD1	I	2	
							F	ISI_MCK	O	3	
138	VDDIN_3V3	GPIO	PC8	I/O	-	-	A	LCDDEN	O	1	PIO, I, PU, ST
							B	NANDRDY	I	1	
							C	FIQ	I	1	
							D	PCK0	O	3	
							E	UTXD1	O	2	
							F	ISI_FIELD	I	3	
2 ⁽²⁾	VDDISC	GPIO	PC9	I/O	-	-	A	FIQ	I	3	PIO, I, PU, ST
							C	ISI_D0	I	1	
							D	TIOA4	I/O	2	
9 ⁽²⁾	VDDISC	GPIO	PC10	I/O	-	-	A	LCDDAT2	O	2	PIO, I, PU, ST
							C	ISI_D1	I	1	
							D	TIOB4	I/O	2	
							E	CANTX0	O	2	
175 ⁽²⁾	VDDISC	GPIO	PC11	I/O	-	-	A	LCDDAT3	O	2	PIO, I, PU, ST
							C	ISI_D2	I	1	
							D	TCLK4	I	2	
							E	CANRX0	I	2	
							F	A0/NBS0	O	2	
3 ⁽²⁾	VDDISC	GPIO	PC12	I/O	-	-	A	LCDDAT4	O	2	PIO, I, PU, ST
							C	ISI_D3	I	1	
							D	URXD3	I	1	
							E	TK0	I/O	2	
							F	A1	O	2	

SAMA5D27 SOM1

Pinout

.....continued

Pad No.	Power Rail	I/O Type	Primary		Alternate		PIO Peripheral				Reset State (Signal, Dir, PU, PD, HIZ, ST)
			Signal	Dir	Signal	Dir	Func	Signal	Dir	IO Set	
4 ⁽²⁾	VDDISC	GPIO	PC13	I/O	-	-	A	LCDDAT5	O	2	PIO, I, PU, ST
							C	ISI_D4	I	1	
							D	UTXD3	O	1	
							E	TF0	I/O	2	
							F	A2	O	2	
8 ⁽²⁾	VDDISC	GPIO	PC14	I/O	-	-	A	LCDDAT6	O	2	PIO, I, PU, ST
							C	ISI_D5	I	1	
							E	TD0	O	2	
							F	A3	O	2	
12 ⁽²⁾	VDDISC	GPIO	PC15	I/O	-	-	A	LCDDAT7	O	2	PIO, I, PU, ST
							C	ISI_D6	I	1	
							E	RD0	I	2	
							F	A4	O	2	
174 ⁽²⁾	VDDISC	GPIO	PC16	I/O	-	-	A	LCDDAT10	O	2	PIO, I, PU, ST
							C	ISI_D7	I	1	
							E	RK0	I/O	2	
							F	A5	O	2	
5 ⁽²⁾	VDDISC	GPIO	PC17	I/O	-	-	A	LCDDAT11	O	2	PIO, I, PU, ST
							C	ISI_D8	I	1	
							E	RF0	I/O	2	
							F	A6	O	2	
172 ⁽²⁾	VDDISC	GPIO	PC18	I/O	-	-	A	LCDDAT12	O	2	PIO, I, PU, ST
							C	ISI_D9	I	1	
							E	FLEXCOM3_IO2	I/O	2	
							F	A7	O	2	
6 ⁽²⁾	VDDISC	GPIO	PC19	I/O	-	-	A	LCDDAT13	O	2	PIO, I, PU, ST
							C	ISI_D10	I	1	
							E	FLEXCOM3_IO1	I/O	2	
							F	A8	O	2	
14 ⁽²⁾	VDDISC	GPIO	PC20	I/O	-	-	A	LCDDAT14	O	2	PIO, I, PU, ST
							C	ISI_D11	I	1	
							E	FLEXCOM3_IO0	I/O	2	
							F	A9	O	2	

SAMA5D27 SOM1

Pinout

.....continued

Pad No.	Power Rail	I/O Type	Primary		Alternate		PIO Peripheral				Reset State (Signal, Dir, PU, PD, HIZ, ST)
			Signal	Dir	Signal	Dir	Func	Signal	Dir	IO Set	
7 ⁽²⁾	VDDISC	GPIO	PC21	I/O	-	-	A	LCDDAT15	O	2	PIO, I, PU, ST
							C	ISI_PCK	I	1	
							E	FLEXCOM3_IO3	O	2	
							F	A10	O	2	
11 ⁽²⁾	VDDISC	GPIO	PC22	I/O	-	-	A	LCDDAT18	O	2	PIO, I, PU, ST
							C	ISI_VSYNC	I	1	
							E	FLEXCOM3_IO4	O	2	
							F	A11	O	2	
170 ⁽²⁾	VDDISC	GPIO	PC23	I/O	-	-	A	LCDDAT19	O	2	PIO, I, PU, ST
							C	ISI_HSYNC	I	1	
							F	A12	O	2	
13 ⁽²⁾	VDDISC	GPIO_CLK	PC24	I/O	-	-	A	LCDDAT20	O	2	PIO, I, PU, ST
							C	ISI_MCK	O	1	
							F	A13	O	2	
173 ⁽²⁾	VDDISC	GPIO	PC25	I/O	-	-	A	LCDDAT21	O	2	PIO, I, PU, ST
							C	ISI_FIELD	I	1	
							F	A14	O	2	
115 ⁽²⁾	VDDIN_3V3	GPIO	PC26	I/O	-	-	A	LCDDAT22	O	2	PIO, I, PU, ST
							D	CANTX1	O	1	
							F	A15	O	2	
114 ⁽²⁾	VDDIN_3V3	GPIO	PC27	I/O	-	-	A	LCDDAT23	O	2	PIO, I, PU, ST
							C	PCK1	O	2	
							D	CANRX1	I/O	1	
							F	A16	O	2	
117 ⁽²⁾	VDDIN_3V3	GPIO	PC28	I/O	-	-	A	LCDPWM	O	2	PIO, I, PU, ST
							B	FLEXCOM4_IO0	I/O	1	
							C	PCK2	O	1	
							F	A17	O	2	
118	VDDIN_3V3	GPIO	PC29	I/O	-	-	A	LCDDISP	O	2	PIO, I, PU, ST
							B	FLEXCOM4_IO1	I/O	1	
							F	A18	O	2	
120	VDDIN_3V3	GPIO	PC30	I/O	-	-	A	LCDVSYNC	O	2	PIO, I, PU, ST
							B	FLEXCOM4_IO2	I/O	1	
							F	A19	O	2	

SAMA5D27 SOM1

Pinout

.....continued

Pad No.	Power Rail	I/O Type	Primary		Alternate		PIO Peripheral				Reset State (Signal, Dir, PU, PD, HIZ, ST)
			Signal	Dir	Signal	Dir	Func	Signal	Dir	IO Set	
116	VDDIN_3V3	GPIO	PC31	I/O	-	-	A	LCDHSYNC	O	2	PIO, I, PU, ST
							B	FLEXCOM4_IO3	O	1	
							C	URXD3	I	2	
							F	A20	O	2	

Notes:

1. Fixed feature due to the SOM internal connection.
2. Limited feature compared to SAMA5D2 due to the SOM internal use of specific functionality, for example, QSPI, GMAC.
3. Limited feature compared to SAMA5D2 due to the use of a part of the functionality for other features in the SOM, for example, GMAC, ISC, Flexcom, etc.

4.2.4 PIOD Pin Description

Table 4-4. System-On-Module Pin Description: PIOD

Pad No.	Power Rail	I/O Type	Primary		Alternate		PIO Peripheral				Reset State (Signal, Dir, PU, PD, HIZ, ST)
			Signal	Dir	Signal	Dir	Func	Signal	Dir	IO Set	
121 ⁽²⁾	VDDIN_3V3	GPIO_CLK	PD0	I/O	-	-	A	LCDPCK	O	2	PIO, I, PU, ST
							B	FLEXCOM4_IO4	O	1	
							C	UTXD3	O	2	
							F	A23	O	2	
113 ⁽²⁾	VDDIN_3V3	GPIO	PD1	I/O	-	-	A	LCDDEN	O	2	PIO, I, PU, ST
							F	A24	O	2	
23 ^{(2), (3)}	VDDIN_3V3	GPIO_CLK	PD2	I/O	-	-	A	URXD1	I	1	PIO, I, PU, ST
							F	A25	O	2	
24 ^{(2), (3)}	VDDIN_3V3	GPIO_AD	PD3	I/O	PTCROW0	-	A	UTXD1	O	1	PIO, I, PU, ST
							B	FIQ	I	2	
							F	NWAIT	I	2	
27 ^{(2), (3)}	VDDIN_3V3	GPIO_AD	PD4	I/O	PTCROW1	-	A	TWD1	I/O	2	PIO, I, PU, ST
							B	URXD2	I	1	
							F	NCS0	O	2	
21 ^{(2), (3)}	VDDIN_3V3	GPIO_AD	PD5	I/O	PTCROW2	-	A	TWCK1	I/O	2	PIO, I, PU, ST
							B	UTXD2	O	1	
							F	NCS1	O	2	
22 ^{(2), (3)}	VDDIN_3V3	GPIO_AD	PD6	I/O	PTCROW3	-	B	PCK1	O	1	PIO, I, PU, ST
							F	NCS2	O	2	
25 ^{(2), (3)}	VDDIN_3V3	GPIO_AD	PD7	I/O	PTCROW4	-	F	NWR1/NBS1	O	2	PIO, I, PU, ST
28 ^{(2), (3)}	VDDIN_3V3	GPIO_AD	PD8	I/O	PTCROW5	-	F	NANDRDY	I	2	PIO, I, PU, ST
N/A ⁽¹⁾	VDDIN_3V3	GPIO_AD	PD9	I/O	-	-	D	GTCK	O	2	PIO, I, PU, ST

SAMA5D27 SOM1

Pinout

.....continued

Pad No.	Power Rail	I/O Type	Primary		Alternate		PIO Peripheral				Reset State (Signal, Dir, PU, PD, HiZ, ST)
			Signal	Dir	Signal	Dir	Func	Signal	Dir	IO Set	
N/A ⁽¹⁾	VDDIN_3V3	GPIO_AD	PD10	I/O	–	–	D	GTXEN	O	2	PIO, I, PU, ST
N/A ⁽¹⁾	VDDIN_3V3	GPIO_AD	PD11	I/O	–	–	D	GRXDV	I	2	PIO, I, PU, ST
N/A ⁽¹⁾	VDDIN_3V3	GPIO_AD	PD12	I/O	–	–	D	GRXER	I	2	PIO, I, PU, ST
N/A ⁽¹⁾	VDDIN_3V3	GPIO_AD	PD13	I/O	–	–	D	GRX0	I	2	PIO, I, PU, ST
N/A ⁽¹⁾	VDDIN_3V3	GPIO_AD	PD14	I/O	–	–	D	GRX1	I	2	PIO, I, PU, ST
N/A ⁽¹⁾	VDDIN_3V3	GPIO_AD	PD15	I/O	–	–	D	GTX0	O	2	PIO, I, PU, ST
N/A ⁽¹⁾	VDDIN_3V3	GPIO_AD	PD16	I/O	–	–	D	GTX1	O	2	PIO, I, PU, ST
N/A ⁽¹⁾	VDDIN_3V3	GPIO_AD	PD17	I/O	–	–	D	GMDC	O	2	PIO, I, PU, ST
N/A ⁽¹⁾	VDDIN_3V3	GPIO_AD	PD18	I/O	–	–	D	GMDIO	I/O	2	PIO, I, PU, ST
58 ⁽³⁾	VDDIN_3V3	GPIO_AD	PD19	I/O	AD0	–	A	PCK0	O	1	PIO, I, PU, ST
							B	TWD1	I/O	3	
							C	URXD2	I	3	
57 ⁽³⁾	VDDIN_3V3	GPIO_AD	PD20	I/O	AD1	–	A	TIOA2	I/O	3	PIO, I, PU, ST
							B	TWCK1	I/O	3	
							C	UTXD2	O	3	
19 ⁽¹⁾	VDDIN_3V3	GPIO_AD	PD21	I/O	–	–	B	TWD0	I/O	4	PIO, I, PU, ST
20 ⁽¹⁾	VDDIN_3V3	GPIO_AD	PD22	I/O	–	–	B	TWCK0	I/O	4	PIO, I, PU, ST
30 ⁽³⁾	VDDIN_3V3	GPIO_AD	PD23	I/O	AD4	–	A	URXD2	I	2	PIO, I, PU, ST
29 ⁽³⁾	VDDIN_3V3	GPIO_AD	PD24	I/O	AD5	–	A	UTXD2	O	2	PIO, I, PU, ST
110	VDDIN_3V3	GPIO_AD	PD25	I/O	AD6	–	A	SPI1_SPCK	O	3	PIO, I, PU, ST
34	VDDIN_3V3	GPIO_AD	PD26	I/O	AD7	–	A	SPI1_MOSI	I/O	3	PIO, I, PU, ST
							C	FLEXCOM2_IO0	I/O	2	
53	VDDIN_3V3	GPIO_AD	PD27	I/O	AD8	–	A	SPI1_MISO	I/O	3	PIO, I, PU, ST
							B	TCK	I	3	
							C	FLEXCOM2_IO1	I/O	2	
51	VDDIN_3V3	GPIO_AD	PD28	I/O	AD9	–	A	SPI1_NPCS0	I/O	3	PIO, I, PU, ST
							B	TDI	I	3	
							C	FLEXCOM2_IO2	I/O	2	
52 ⁽²⁾	VDDIN_3V3	GPIO_AD	PD29	I/O	AD10	–	A	SPI1_NPCS1	O	3	PIO, I, PU, ST
							B	TDO	O	3	
							C	FLEXCOM2_IO3	O	2	
							D	TIOA3	I/O	3	

SAMA5D27 SOM1

Pinout

.....continued

Pad No.	Power Rail	I/O Type	Primary		Alternate		PIO Peripheral				Reset State (Signal, Dir, PU, PD, HiZ, ST)
			Signal	Dir	Signal	Dir	Func	Signal	Dir	IO Set	
54 ⁽²⁾	VDDIN_3V3	GPIO_AD	PD30	I/O	AD11	-	A	SPI1_NPCS2	O	3	PIO, I, PU, ST
							B	TMS	I	3	
							C	FLEXCOM2_IO4	O	2	
							D	TIOB3	I/O	3	
N/A ⁽¹⁾	VDDIN_3V3	GPIO_AD	PD31	I/O	-	-	C	IRQ	I	4	PIO, I, PU, ST

Notes:

1. Fixed feature due to the SOM internal connection.
2. Limited feature compared to SAMA5D2 due to the SOM internal use of specific functionality, for example, QSPI, GMAC.
3. Limited feature compared to SAMA5D2 due to the use of a part of the functionality for other features in the SOM, for example, GMAC, ISC, Flexcom, etc.

4.2.5 System Pin Description

Table 4-5. System-On-Module Pin Description: System

Pin Number	PIO	Power Rail	Designation	Type
61	CLK_AUDIO	VDDIN_3V3	Audio clock	Output
64	COMP_N	VDDDBU	External analog comparator input	Input
63	COMP_P	VDDDBU	External analog comparator input	Input
126	DIS_BOOT	VDDIN_3V3	QSPI Interface Disable pin	Input
67	USBA_M	VDDIN_3V3	USB Device High-speed Data -	-
68	USBA_P	VDDIN_3V3	USB Device High-speed Data +	-
70	USBB_M	VDDIN_3V3	USB Host Port B High-speed Data -	-
71	USBB_P	VDDIN_3V3	USB Host Port B High-speed Data +	-
74	DATA	VDDHSIC	USB High-speed Inter-Chip Data	-
73	STROBE	VDDHSIC	USB High-speed Inter-Chip Strobe	-
60	NRST	VDDIN_3V3	Microprocessor reset	Input / Active Low
33	PIOBU1	VDDDBU	Tamper or Wake-up input	Input
44	PIOBU2	VDDDBU	Tamper or Wake-up input	Input
48	PIOBU3	VDDDBU	Tamper or Wake-up input	Input
47	PIOBU4	VDDDBU	Tamper or Wake-up input	Input
46	PIOBU5	VDDDBU	Tamper or Wake-up input	Input
59	PIOBU6	VDDDBU	Tamper or Wake-up input	Input
45	PIOBU7	VDDDBU	Tamper or Wake-up input	Input
32	RXD	VDDDBU	Low-Power Asynchronous Receiver	Input
35	SHDN	VDDDBU	Shutdown Control	Output
49	WKUP	VDDDBU	Wake-up	Input
36	ETH_LED0	VDDIN_3V3	Status LED control for Ethernet ports	Output

.....continued

Pin Number	PIO	Power Rail	Designation	Type
37	ETH_RXM	± 2.5V	Physical receive or transmit signal (– differential)	I/O
38	ETH_RXP	± 2.5V	Physical receive or transmit signal (+ differential)	I/O
40	ETH_TXM	± 2.5V	Physical receive or transmit signal (– differential)	I/O
41	ETH_TXP	± 2.5V	Physical receive or transmit signal (+ differential)	I/O

4.2.6 Power Pin Description

Table 4-6. System-On-Module Pin Description: Power

Pin Number	PIO	Description	Comments
16,17	VDDIN_3V3	Main 3.3V Supply inputs. Used for Peripheral I/O lines and MIC2800-G1JJYML supplies.	–
55	VDDBU	Input supply for Slow Clock Oscillator, internal 32 kHz RC Oscillator and a part of the System Controller	–
65	VDDSDHC	SDMMC I/O lines supply input	–
15	VDDISC	Image Sensor I/O lines supply input	–
1, 10, 18, 26, 31, 39, 42, 43, 50, 56, 62, 66, 69, 72, 75, 88, 89, 98, 107, 130, 131, 149, 166, 171, 176	GND	Ground connections	Must be connected together
129	RFU0	Reserved for future use	Must be left floating
147	RFU1	Reserved for future use	Must be left floating
153	RFU2	Reserved for future use	Must be left floating

5. Functional Description

5.1 SAMA5D27 System-In-Package

The SAMA5D2 System-In-Package (SIP) (SAMA5D27C-D1G-CU) integrates the ARM Cortex-A5 processor-based SAMA5D2 MPU with 1 Gbit DDR2-SDRAM in a single package.

By combining the high-performance, ultra-low power SAMA5D2 with DDR2-SDRAM in a single package, PCB routing complexity, area and number of layers is reduced. This makes board design easier and lowers the overall cost of bill of materials. Board design is more robust by facilitating design for EMI, ESD and signal integrity.

For more information about the SIP, see [Reference Documents](#). This section lists the sole reference documents for product information on the SAMA5D2 and the DDR2-SDRAM memory.

The SAMA5D27C-D1G-CU is available in a 289-ball TFBGA package.

Connections of the supplies and the system pins of the SAMA5D27C-D1G-CU are described in the following schematics.

Figure 5-1. SAMA5D27C-D1G-CU Supplies Distribution Schematic

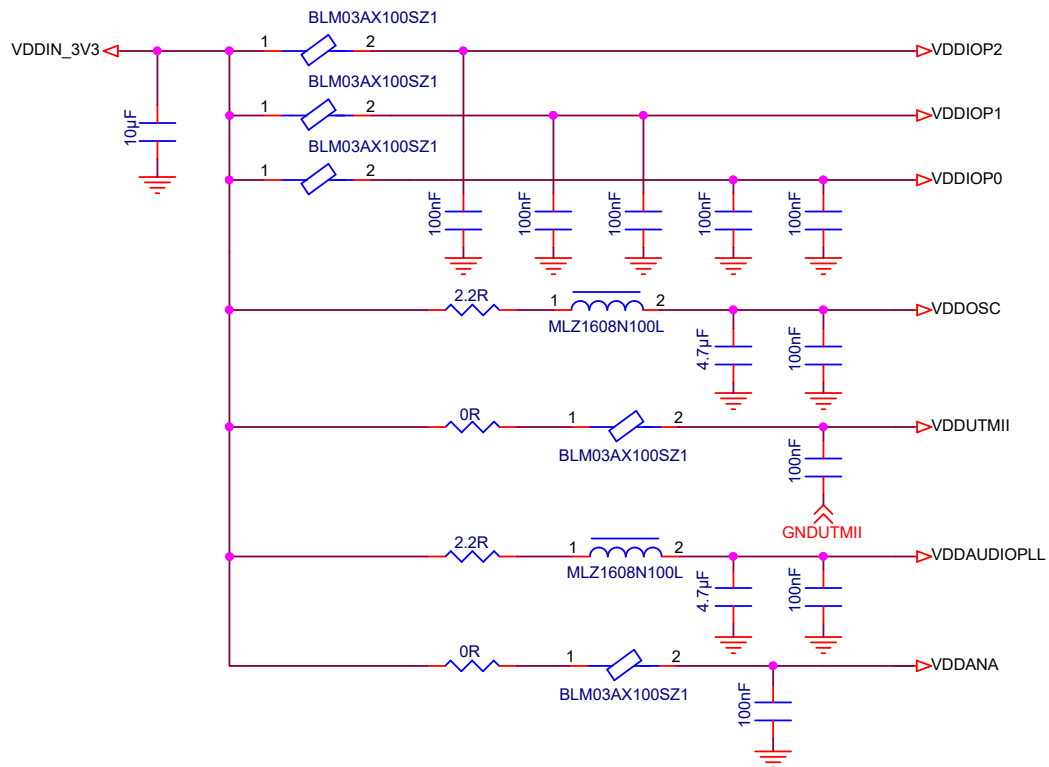

SAMA5D27 SOM1

Functional Description

Figure 5-2. SAMA5D27C-D1G-CU Supplies Decoupling Schematic

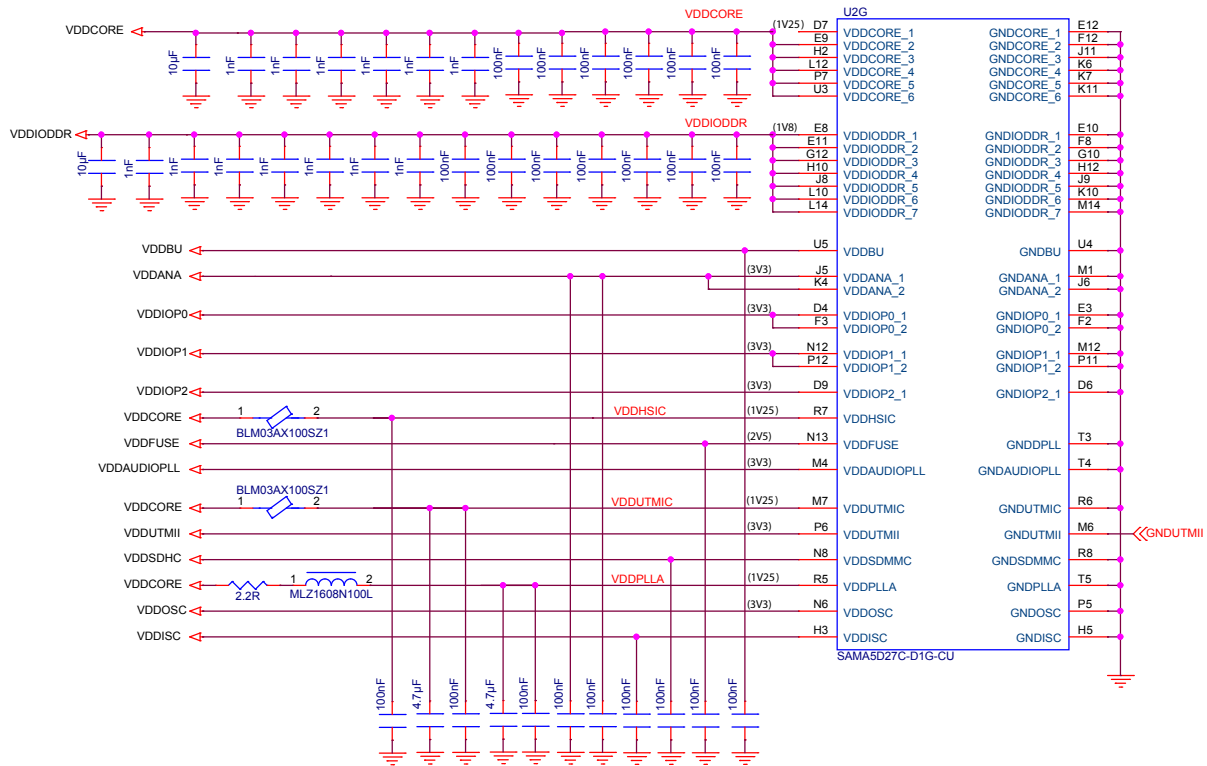
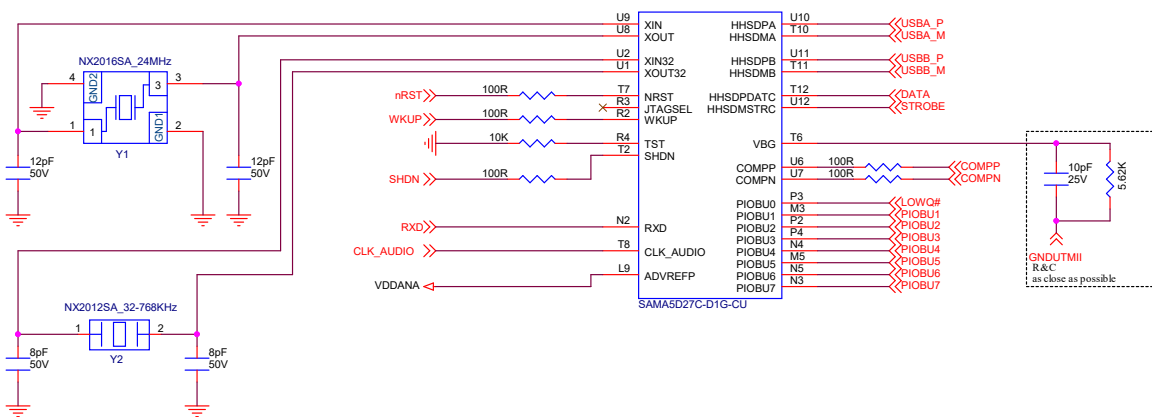

Figure 5-3. SAMA5D27C-D1G-CU System Schematic



5.2 Power Supplies

The SAMA5D27 SOM1 is supplied by an external 3.3V and generates its own internal supplies by interfacing with the Microchip MIC2800-G1JJYML Power Management Unit.

The MIC2800 is a high-performance power management IC, providing three output voltages with maximum efficiency and is optimized to respect the MPU power-up and power-down cycles.

SAMA5D27 SOM1

Functional Description

Integrating a 2 MHz DC/DC converter with an LDO post regulator, the MIC2800 gives two high-efficiency outputs with a second, 300mA LDO for maximum flexibility. The DC-to-DC converter uses small values of L and C to reduce board space while still retaining efficiency over 90% at load currents up to 600mA.

The three outputs supply the following internal nodes:

- DCDC set @ 1.8V supplies SAMA5D27C-D1G-CU DDR2 pads and device.
- LDO1 set @ 1.25V supplies SAMA5D27C-D1G-CU Core.
- LDO2 set @ 2.5V supplies SAMA5D27C-D1G-CU VDDFUSE pad.

The MIC2800 is a μ Cap design, operating with very small ceramic output capacitors and inductors for stability.

It is available in fixed output voltages in the 16-pin 3mm x 3mm MLF[®] lead-less package. For more information, refer to the [product web page](#).

Figure 5-4. Power Management Unit Schematic

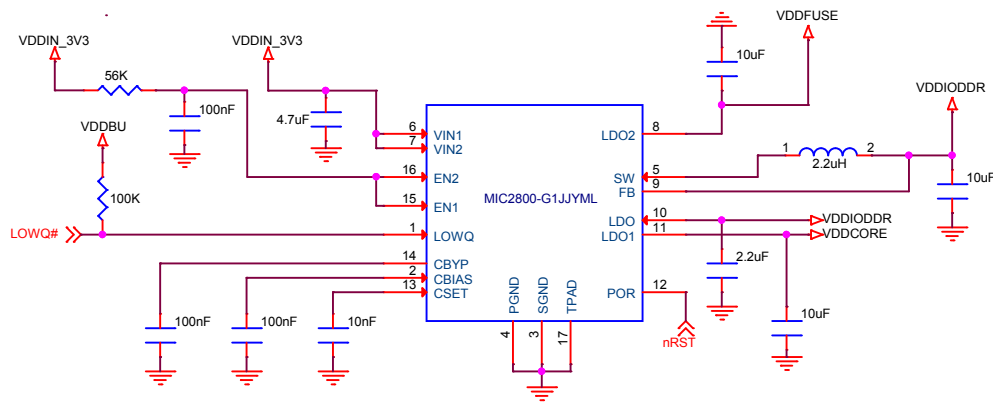

5.3 System Control

The SAMA5D27 SOM1 provides global system Reset (nRST) and Shutdown (SHDN) pins to the application board.

- The nRST pin is an output pin generated by the internal Power Management Unit (MIC2800-G1JJYML) in respect with power sequence timing. It can be forced externally in case of a system crash and must be connected as described in the example schematic below.
- The SHDN pin is an output pin and is managed by the software application. It switches the Main 3.3V Supply ON or OFF.

Figure 5-5. Internal System Control Schematic

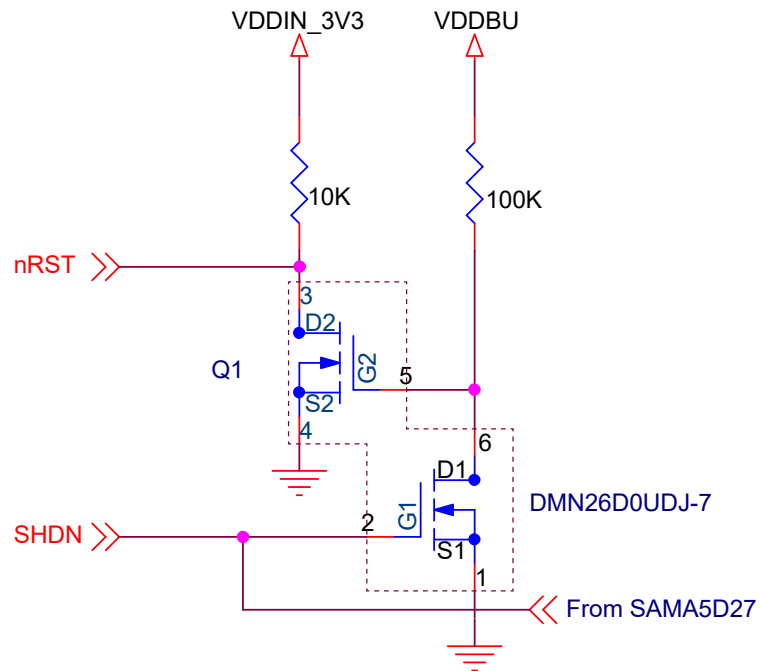

5.4 Ethernet PHY

The Microchip SAMA5D27 SOM1 embeds a single-supply 10BASE-T/100BASE-TX Ethernet physical-layer transceiver for transmission and reception of data over standard CAT-5 unshielded twisted pair (UTP) cable.

The KSZ8081RNAIA is a highly-integrated PHY solution. The KSZ8081RNAIA offers the Reduced Media Independent Interface (RMII) for direct connection to RMII-compliant MACs in Ethernet processors.

The KSZ8081RNAIA is available in 24-pin, lead-free QFN packages. For more information, refer to the [product web page](#).

Figure 5-6. Ethernet PHY Schematic

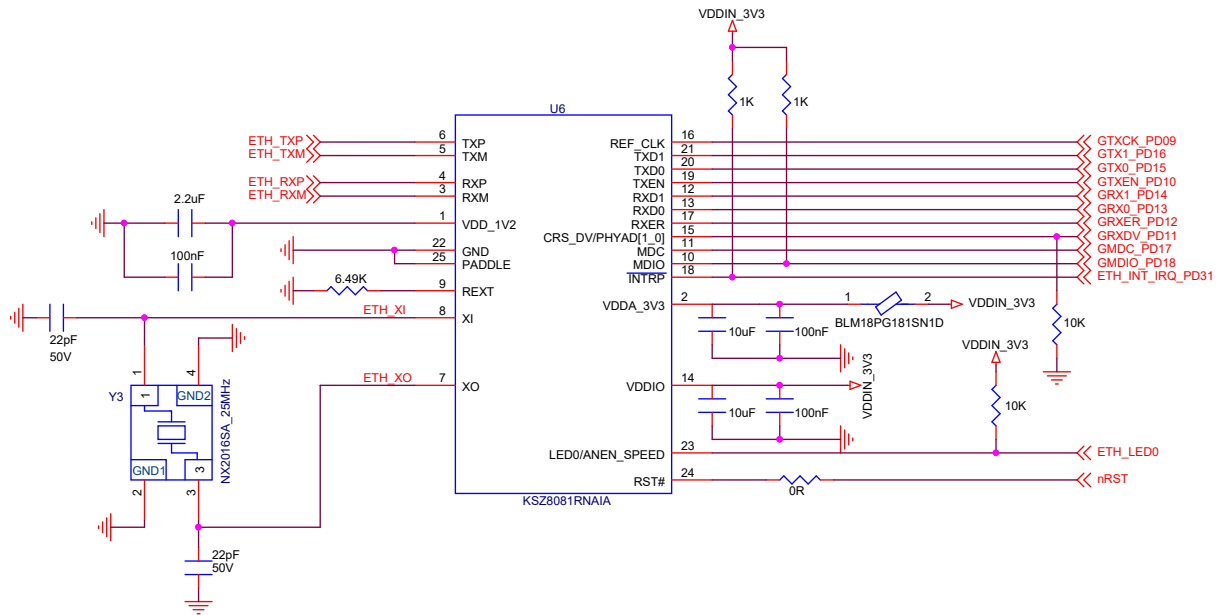

5.5 QSPI Memory

The SAMA5D27 SOM1 embeds the SST26VF064BT-104I/MF, a 64Mb Serial Quad I/O Flash memory.

The SST26VF064BT-104I/MF SQI features a six-wire, 4-bit I/O interface that allows for low-power, high-performance operation in a low pin-count package.

The SST26VF064BT-104I/MF is available in 8-lead WDFN package with 6mm × 5mm dimensions.

For more information, refer to the [product web page](#).

Figure 5-7. QSPI Memory Schematic

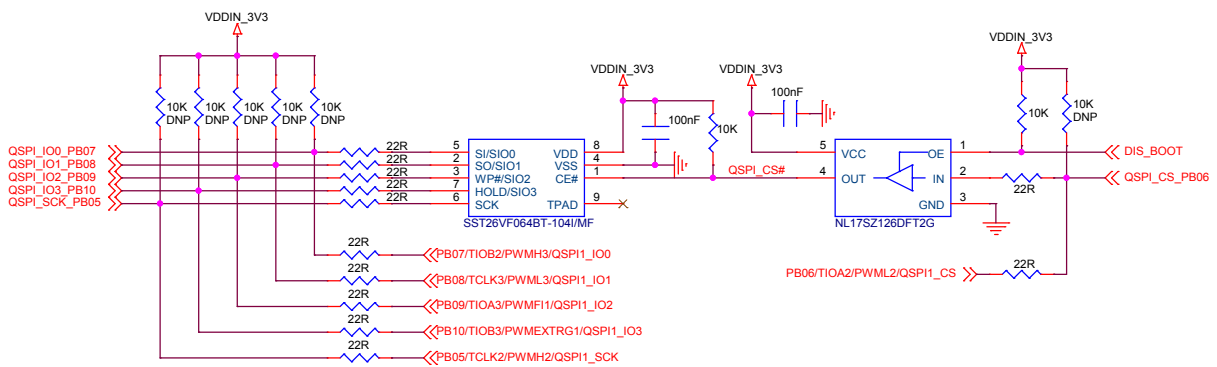

Tip: In case of non-use at application level of the QSPI embedded in SAMA5D27 SOM1, it is possible to reassign the signals dedicated to QSPI memory to another PIO function as defined in the table below. To do so, the DIS_BOOT pin (SAMA5D27 SOM1 pad 126) must be forced to ground.

SAMA5D27 SOM1

Functional Description

Table 5-1. Other GPIO Possibilities for QSPI Interface in Case of Non-use

Pin Number	Power Rail	Primary		PIO Peripheral				Reset State
		Signal	Dir	Func	Signal	Dir	IOset	
134	VDDIN_3V3	PB5	I/O	A	TCLK2	I	1	PIO, I, PU, ST
				C	PWMH2	O	1	
				D	QSPI1_SCK	O	2	
127	VDDIN_3V3	PB6	I/O	A	TIOA2	I/O	1	PIO, I, PU, ST
				C	PWML2	O	1	
				D	QSPI1_CS	O	2	
133	VDDIN_3V3	PB7	I/O	A	TIOB2	I/O	1	PIO, I, PU, ST
				C	PWMH3	O	1	
				D	QSPI1_IO0	I/O	2	
128	VDDIN_3V3	PB8	I/O	A	TCLK3	I	1	PIO, I, PU, ST
				C	PWML3	O	1	
				D	QSPI1_IO1	I/O	2	
132	VDDIN_3V3	PB9	I/O	A	TIOA3	I/O	1	PIO, I, PU, ST
				C	PWMF11	I	1	
				D	QSPI1_IO2	I/O	2	
135	VDDIN_3V3	PB10	I/O	A	TIOB3	I/O	1	PIO, I, PU, ST
				C	PWMEXTRG1	I	1	
				D	QSPI1_IO3	I/O	2	



Tip: The QSPI interface can be shared with another external device. To do so, the QSPI_CS# node must stay at "High" level. That means that the DIS_BOOT pin (SAMA5D27 SOM1 pad 126) must be forced to ground.

5.6 EEPROM Memory

The SAMA5D27 SOM1 embeds the 24AA02E48T-I/OT, a 1Kb Serial EEPROM with pre-programmed EUI-48 MAC address.

The device is organized as one block of 128 x 8-bit memory with a 2-wire serial interface. The second block is reserved for MAC Address storage.

The 24AA02E48T-I/OT also has a page write capability for up to 8 bytes of data.

The 24AA02E48T-I/OT is available in the standard 5-lead SOT-23 package. For more information, see the [product web page](#).

Figure 5-8. EEPROM Memory Schematic

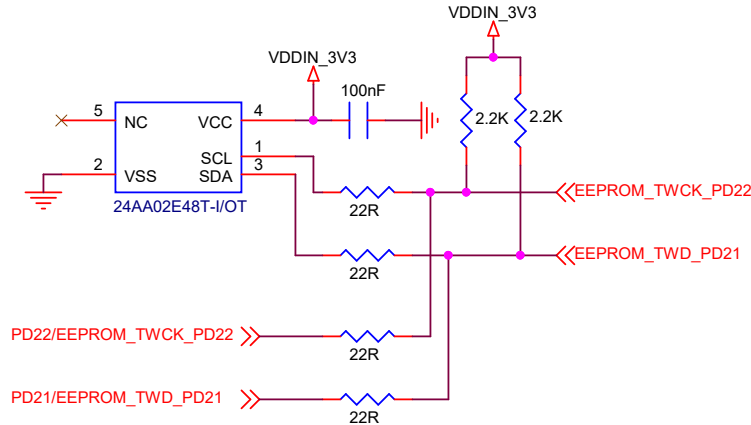

Tip: The 2-Wire serial interface can be externally shared with another device. 2-Wire Data Signal (SAMA5D27 SOM1 Pad 19) and 2-Wire Clock Signal (SAMA5D27 SOM1 Pad 20) are used.



Important: If the 2-Wire serial interface is used externally, the device connected must have a different I²C address than the embedded EEPROM. For more details, refer to the device data sheet.

6. Power Supply Connections and Timing Sequences

The SAMA5D27 SOM1 can be supplied in different ways depending on application needs.

Four power domains must be supplied and can be connected differently. The four different power connections are described below:

- Power Configuration #1: All supplies are connected to the Main 3.3V Supply.
- Power Configuration #2: Backup domain is connected to a coin-cell and the rest to the Main 3.3V Supply.
- Power Configuration #3: Backup domain is connected to a coin-cell. Camera sensor is connected to a separate power supply and the rest to the Main 3.3V Supply.
- Power Configuration #4: All supply domains are connected to separate power supplies.

For each power configuration, the power-on and power-off timing sequences to respect are described below.

6.1 Power Supply Configuration #1

The SAMA5D27 SOM1 is supplied by only one main supply.

In this configuration mode, all supplies are connected together and supplied by the main 3.3V supply. All PIOs have VDDIN_3V3 Power Rail as voltage reference.

Figure 6-1. Power Configuration #1

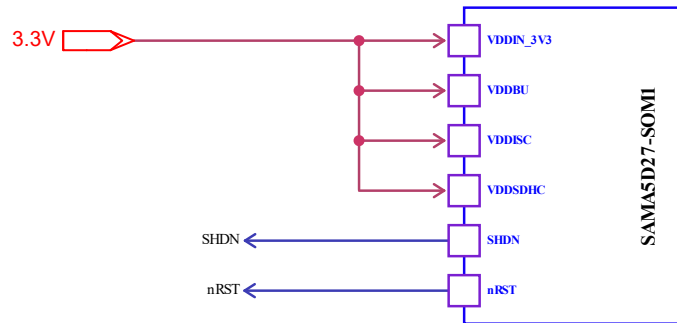

In this configuration mode, the two following timing sequences are applied.

Figure 6-2. Power-On Sequence Timing Diagram

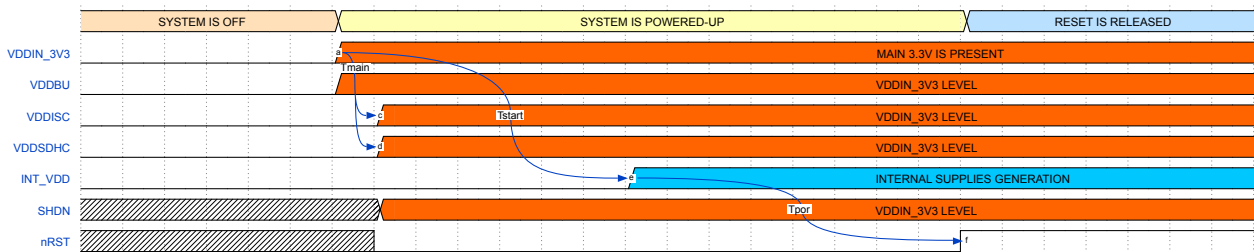

Figure 6-3. Power-Off Sequence Timing Diagram

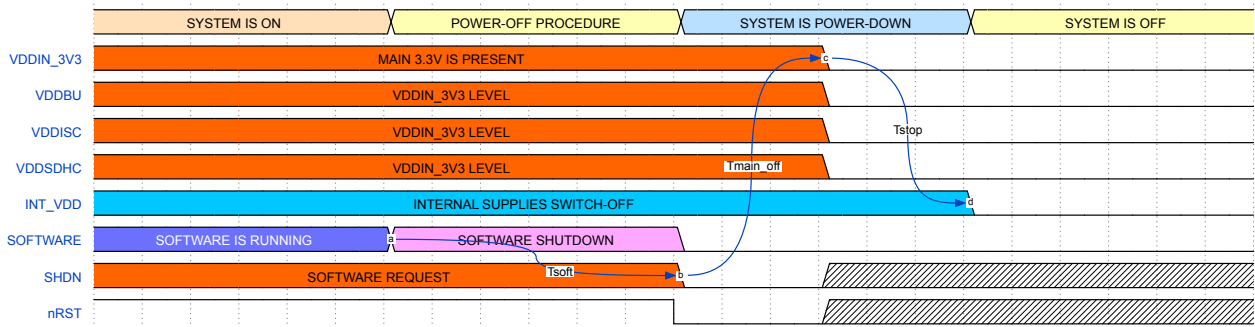

Table 6-1. Timing Values

Symbol	Description	Min.	Typ.	Max.	Unit
$t_{main}^{(1)}$	Main 3.3V Start-up Time	–	–	1	ms
t_{start}	Internal Delay before starting System Core Supplies	1	–	3	ms
t_{por}	Power-on Reset Delay	–	10	11	ms
t_{soft}	Software Shutdown Time	Depending on system off time			ms
t_{main_off}	Main 3.3V Power-off Time	–	–	1	ms
t_{stop}	Internal Delay before switching off System Core Supplies	1	–	3	ms

Note:

1. The three supplies VDDIN_3V3, VDDISC and VDDSDHC must be applied at the same time. If a delay is implemented, it must be lower than 800µs. VDDBU must be applied at the same time as VDDIN_3V3 or just before. It is forbidden to apply VDDBU after VDDIN_3V3.

6.2 Power Supply Configuration #2

The SAMA5D27 SOM1 is supplied by different power supplies.

- Backup domain is connected to a coin-cell supply.
- The rest of the power inputs are connected to the main 3.3V supply.

In this configuration, the following PIOs have VDDBU Power Rail as reference. All other PIO have VDDIN_3V3 Power Rail as reference.

- COMPP and COMPN
- PIOBU1 to PIOBU7
- RXD, SHDN and WKUP

Figure 6-4. Power Configuration #2

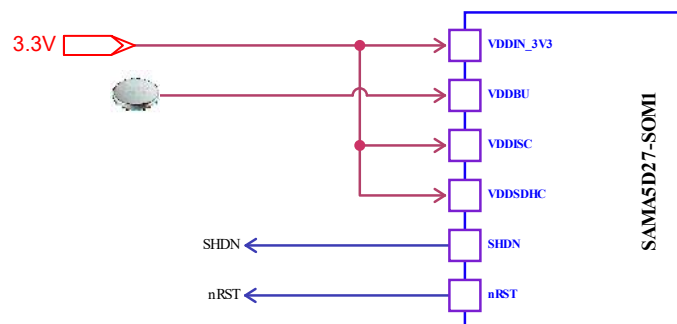

In this configuration, the two following timing sequences are applied.

Figure 6-5. Power-On Sequence Timing Diagram

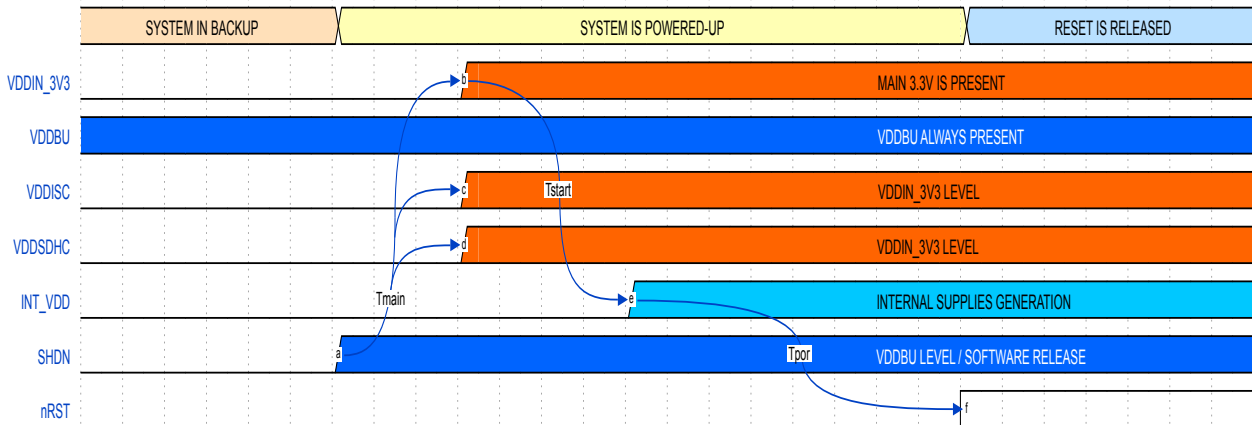

Figure 6-6. Power-Off Sequence Timing Diagram

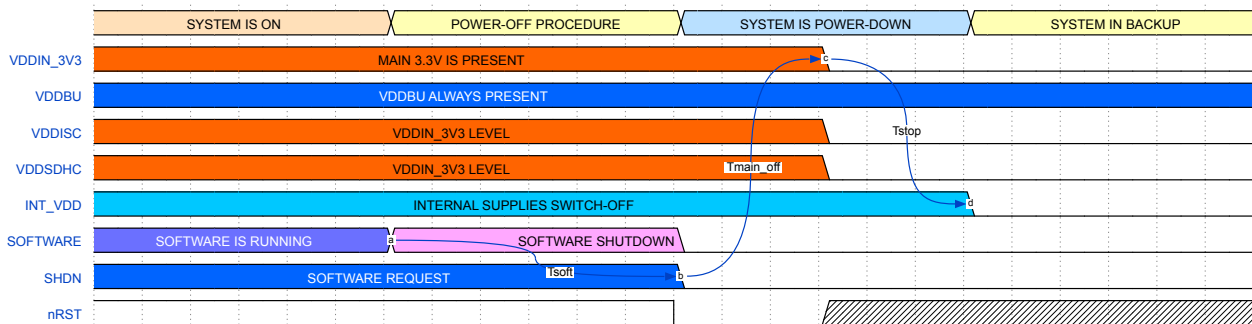

Table 6-2. Timing Values

Symbol	Description	Min.	Typ.	Max.	Unit
$t_{main}^{(1)}$	Main 3.3V Start-up Time	–	–	1	ms
t_{start}	Internal Delay before starting System Core Supplies	1	–	3	ms
t_{por}	Power-on Reset Delay	–	10	11	ms
t_{soft}	Software Shutdown Time	Depending on system off time			ms
t_{main_off}	Main 3.3V Power-off Time	–	–	1	ms
t_{stop}	Internal Delay before switching-off System Core Supplies	1	–	3	ms

Note:

1. The three supplies VDDIN_3V3, VDDISC and VDDSDHC must be applied at the same time. If a delay is implemented, it must be lower than t_{start} .

6.3 Power Supply Configuration #3

Some power inputs of the SAMA5D27 SOM1 are grouped and others are supplied by a separated power supplies.

- Backup domain is connected to a coin cell.
- Camera sensor power input (VDDISC) is connected to a separate power supply set at one of the following voltage levels (1.8V/2.5V/2.8V/3.0V or 3.3V) depending on the camera sensor technology used in the application.
- The remaining power inputs are connected to the main 3.3V supply.

SAMA5D27 SOM1

Power Supply Connections and Timing ...

In this configuration, the following PIOs have:

- VDDBU Power Rail as reference
 - COMPP and COMPN
 - PIOBU1 to PIOBU7
 - RXD, SHDN and WKUP
- VDDISC Power Rail as reference
 - PC9 to PC25
- All other PIOs have VDDIN_3V3 Power Rail as reference.

Figure 6-7. Power Configuration #3

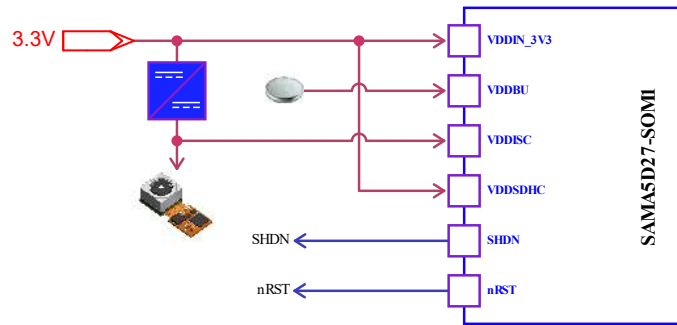

In this configuration mode, the two following timing sequences are applied.

Figure 6-8. Power-On Sequence Timing Diagram

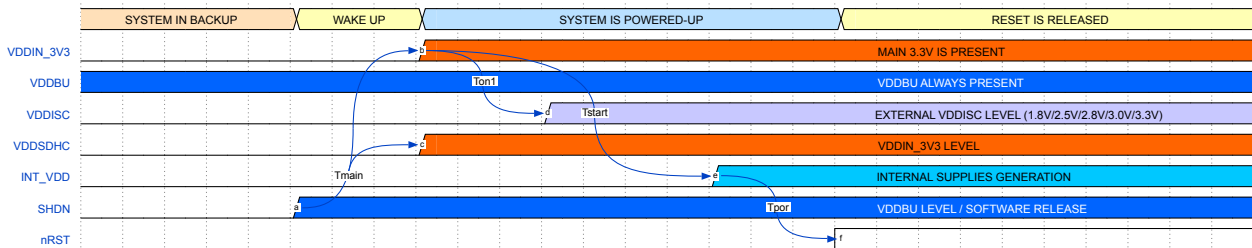

Figure 6-9. Power-Off Sequence Timing Diagram

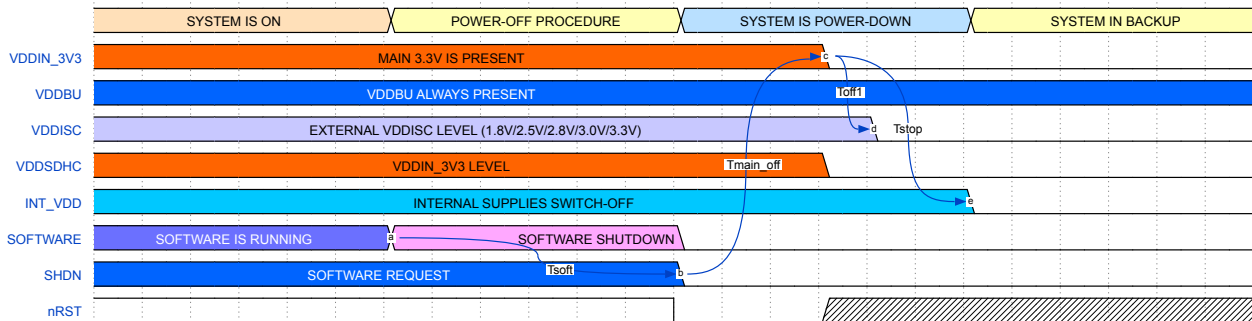

Table 6-3. Timing Values

Symbol	Description	Min.	Typ.	Max.	Unit
$t_{main}^{(1)}$	Main 3.3V Start-up Time (From regulator available on the motherboard)	–	–	1	ms
t_{on1}	VDDISC Regulator Start-up Time (From regulator available on the motherboard)	–	–	800	μ s
t_{start}	Internal Delay before starting System Core Supplies	1	–	3	ms

.....continued

Symbol	Description	Min.	Typ.	Max.	Unit
t_{por}	Power-on Reset Delay	–	10	11	ms
t_{soft}	Software Shutdown Time	Depending on system off time			ms
t_{main_off}	Main 3.3V Power-off Time (From regulator available on the motherboard)	–	–	1	ms
t_{off1}	VDDISC Regulator Power-off Time (From regulator available on the motherboard)	–	–	1	ms
t_{stop}	Internal Delay before switching off System Core Supplies	1	–	3	ms

Note:

- The supplies VDDIN_3V3 and VDDSDHC must be applied at the same time. If a delay is implemented, it must be lower than t_{start} .

6.4 Power Supply Configuration #4

Each power input of the SAMA5D27 SOM1 is supplied by separate power supplies.

- Backup domain is connected to a coin cell.
- Camera sensor power input (VDDISC) is connected to a separate power supply set at one of the following voltage levels (1.8V/2.5V/2.8V/3.0V or 3.3V) depending on the camera sensor technology used in the application.
- SD Card power input (VDDSDHC) is connected to a separate power supply set at one of the following voltage levels (1.8V or 3.3V) depending on the SD Card Technology/Speed used in the application.
- VDDIN_3V3 power input is connected to the main 3.3V supply.

In this configuration, the following PIOs have:

- VDDBU Power Rail as reference
 - COMPP and COMPN
 - PIOBU1 to PIOBU7
 - RXD, SHDN and WKUP
- VDDISC Power Rail as reference
 - PC9 to PC25
- VDDSDHC Power Rail as reference
 - PA0 to PA10
- All other PIOs have VDDIN_3V3 Power Rail as reference.

Figure 6-10. Power Configuration #4

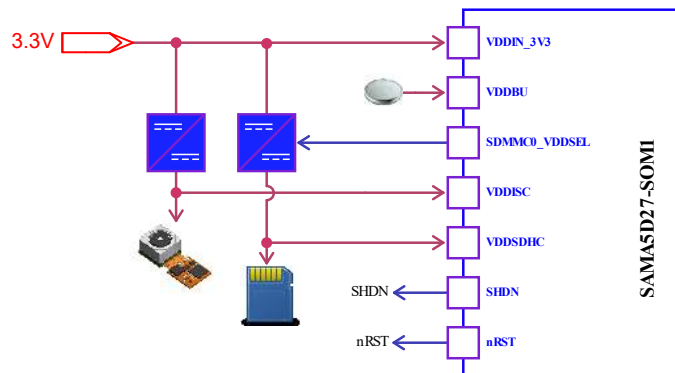

SAMA5D27 SOM1

Power Supply Connections and Timing ...

In this configuration mode, the two following timing sequences are applied.

Figure 6-11. Power-On Sequence Timing Diagram

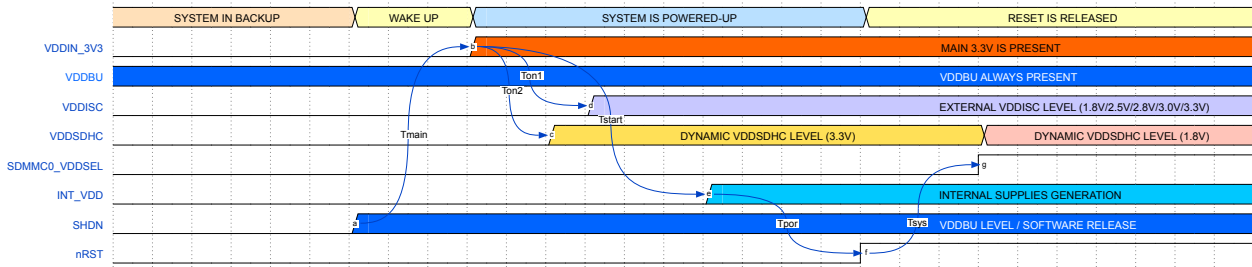

Figure 6-12. Power-Off Sequence Timing Diagram

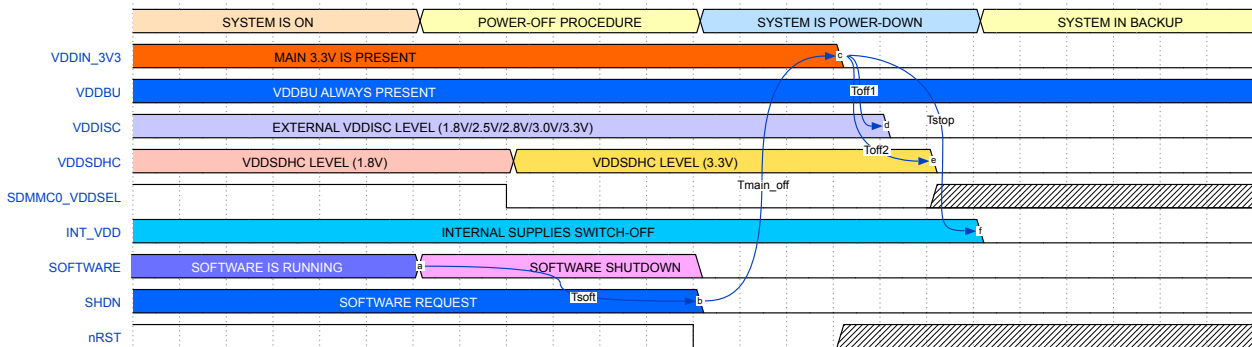

Table 6-4. Timing Values

Symbol	Description	Min.	Typ.	Max.	Unit
t_{main}	Main 3.3V Start-up Time (From regulator available on the mother board)	–	–	1	ms
t_{on1}	VDDISC Regulator Start-up Time (From regulator available on the mother board)	–	–	800	μ s
t_{on2}	VDDSDHC Regulator Start-up Time (From regulator available on the mother board)	–	–	800	μ s
t_{start}	Internal Delay before starting System Core Supplies	1	–	3	ms
t_{por}	Power-on Reset Delay	–	10	11	ms
t_{sys}	Low-speed to High-speed Card Timing ⁽¹⁾	Depending on system on time			ms
t_{soft}	Software Shutdown Time	Depending on system off time			ms
t_{main_off}	Main 3.3V Power-off Time (From regulator available on the motherboard)	–	–	1	ms
t_{off1}	VDDISC Regulator Power-off Time (From regulator available on the motherboard)	–	–	1	ms
t_{off2}	VDDSDHC Regulator Power-off Time (From regulator available on the motherboard)	–	–	1	ms
t_{stop}	Internal Delay before switching off System Core Supplies	1	–	3	ms

Note:

1. Timing depends on the system boot time. No particular recommendations to apply.

7. Booting Guidelines

This section provides an overview of how to program a Non-Volatile Memory (NVM) and boot from it.

The SAMA5D27 SOM1 embeds a Quad I/O Flash Memory as a source for boot. Another type of NVM may be located on the motherboard. This section explains how to program, select and boot from an NVM.

7.1 Boot Process

The system always boots from the ROM memory at address 0x0. The ROM code is a boot program contained in the embedded ROM. It is also called "First level bootloader". The SAMA5D2 can be configured to run a Standard Boot mode or a Secure Boot mode. More information on how the Secure Boot mode can be enabled, and how the chip operates in this mode, is provided in the document *SAMA5D2x Secure Boot Strategy*. To obtain this application note and additional information about the secure boot and related tools, contact a Microchip sales representative.

By default, the chip starts in Standard Boot Mode.

The ROM code standard sequence is executed as follows:

- Basic chip initialization: crystal or external clock frequency detection.
- Attempt to retrieve a valid code from external non-volatile memories (NVM).
- Execution of a monitor called SAM-BA[®] Monitor, in case no valid application has been found on any NVM ⁽¹⁾.

Note:

1. This may be the case during the first start-up or after an NVM erase or when a "boot disable jumper" is used on the memory Chip Select, in order to force an update.

7.2 Boot Configuration

The boot sequence is controlled using a Boot Configuration Word in the Fuse area or in the backup registers BUREG.

For details, refer to the section "Boot Configuration" of the *SAMA5D2 Data Sheet*, document no. DS60001476.

7.3 NVM Programming

The SAMA5D27 SOM1 is delivered with SAM-BA[®] In-System Programmer, a comprehensive tool to program boot memories.

In case the boot code does not find a valid program in NVM, the SAM-BA monitor is launched in order to program the considered NVM.

The SAM-BA monitor principle is to:

- Initialize DBGU and USB.
- Check if USB Device enumeration occurred.
- Check if characters are received on the DBGU.

Once the communication interface is identified, the application runs in an infinite loop waiting for different commands.

The firmware can be sent and programmed in the NVM.

For more information, refer to the following link: www.at91.com/linux4sam/bin/view/Linux4SAM/Sama5d2XplainedMainPage#Using_SAM_BA_to_flash_components.

7.4 Boot From External Memory

Several types of external memories such as NAND Flash, SDCard, SPI Flash, QSPI Flash, etc. can be connected to the SAMA5D27 SOM1 and placed on the motherboard.

SAMA5D27 SOM1

Booting Guidelines

For details of the Boot sequence, refer to the "NVM Bootloader Program Description for MRL C Parts" diagram of the SAMA5D2 data sheet, document no. DS60001476.

The table below provides the list of external memory types and interfaces that may be used to boot the SAMA5D27 SOM1:

Table 7-1. External Memory Connections

Memory Type	Interface	PIO	Comments
SDCard	SDMMC0	PA0 to PA13	If external SDMMC0 interface is not used, bit SDMMC_0 in Boot Configuration Word must be set to 1.
	SDMMC1	PA18 to PA22, PA27 to PA30	If external SDMMC1 Interface is not used, bit SDMMC_1 in Boot Configuration Word must be set to 1.
eMMC	SDMMC0	PA0 to PA10, PA13	If external SDMMC0 Interface is not used, bit SDMMC_0 in Boot Configuration Word must be set to 1.
	SDMMC1	PA18 to PA22, PA27, PA30	If external SDMMC0 interface is not used, bit SDMMC_1 in Boot Configuration Word must be set to 1.
NAND Flash	NFC	PA0 to PA12	Field NFC in Boot Configuration Word must be set to "01". IOSET2 is selected. (See Notes below)
		PA22 to PA31, PB0 to PB2, PC8	Field NFC in Boot Configuration Word must be set to "00". IOSET1 is selected. (See Notes below)
QSPI Flash	QSPI0	PA0 to PA5	Field QSPI_0 in Boot Configuration Word must be set to "00". IOSET1 is selected. (See Notes below)
		PA14 to PA19	Field QSPI_0 in Boot Configuration Word must be set to "01". IOSET2 is selected. (See Notes below)
		PA22 to PA27	Field QSPI_0 in Boot Configuration Word must be set to "10". IOSET3 is selected. (See Notes below)
	QSPI1	PB5 to PB10	Need to tie DIS-BOOT pin to GND. Bits QSPI_1 in Boot Configuration Word must be set to "01". IOSET2 is selected. (See Notes below)
SPI Flash	SPI0	PA14 to PA17	Bits SPI_0 in Boot Configuration Word must be set to "00". IOSET1 is selected. (See Notes below)
		PA30, PA31, PB0, PB1	Bits SPI_0 in Boot Configuration Word must be set to "01". IOSET2 is selected. (See Notes below)
	SPI1	PA22 to PA25	Bits SPI_1 in Boot Configuration Word must be set to "01". IOSET2 is selected. (See Notes below)
		PC1 to PC4	Bits SPI_1 in Boot Configuration Word must be set to "00". IOSET1 is selected. (See Notes below)

Note: For these external memory configurations, set the EXT_MEM_BOOT_ENABLE bit to "1" in **Boot Configuration Word**.

Note: The Boot Configuration Word allows several customizations of the boot sequence. For details, refer to the section "Boot Configuration" in the *SAMA5D2 Data Sheet*, document no. DS60001476.

8. Debug Considerations

The SAMA5D27 SOM1 JTAG access is disabled during the execution of the ROM code sequence. It is re-enabled when jumping into SRAM when a valid code has been found on an external NVM, at the same time the ROM memory and fuses are hidden. If no valid boot is found on an external NVM, the ROM code

- enables the USB connection and one UART serial port
- starts the standard SAM-BA monitor
- locks access to the ROM memory
- re-enables the JTAG connection

The SAMA5D27 SOM1 has multiple debug and JTAG settings. For more information, refer to the *SAMA5D2 Data Sheet*, document no. DS60001476, "SECUMOD JTAG Protection Control Register", "Customer Fuse Matrix" and "Special Function Bits".

The JTAG I/O set can be configured. For correct operations, the I/O set to be used is JTAG_IOSET_3, i.e., the field JTAG_IO_SET in the Boot Configuration Word must be written with value '2'.⁽¹⁾

Note: Due to IO conflict on line PA22, JTAG_IOSET_4 must not be implemented when SDMMC1 is used as an NVM boot media. See the *SAMA5D2 Data Sheet*, document no. DS60001476, "Boot Configuration Word".

9. Electrical Characteristics

This section provides an overview of the electrical characteristics of the SAMA5D27 SOM1 module. Absolute maximum ratings for the SAMA5D27 SOM1 module are listed below. Exposure to these maximum rating conditions for extended periods may affect device reliability. Functional operation of the module at these or any other conditions, above the parameters indicated in the operation listings of this specification, is not implied.

9.1 Absolute Maximum Ratings

Table 9-1. Absolute Maximum Ratings

Parameter	Conditions	Min.	Max.
Storage Temperature	–	-60°C	+150°C
Maximum Operating Temperature	–	-40°C	+85°C
Voltage on Inputs Pins	With respect to ground	-0.3V	+4.0V
Maximum Voltage	On VDDIN_3V3 Pads	–	+4.0V
	On VDDBU Pad	–	+4.0V
	On VDDSDHC Pad	–	+4.0V
	On VDDISC Pad	–	+4.0V



Important: Stresses beyond those listed under “Absolute Maximum Ratings” may cause permanent damage to the device. This is a stress rating only and functional operation of the device at these or other conditions beyond those indicated in the operational sections of this specification is not implied. Exposure to absolute maximum rating conditions for extended periods may affect device reliability.

9.2 Operational Characteristics

The following characteristics are applicable to the operating temperature range $T_A = -40^{\circ}\text{C}$ to $+85^{\circ}\text{C}$, unless otherwise specified.

Table 9-2. Table 7. Power Supplies Operating Conditions

Pad	Parameters	Conditions	Min.	Typ.	Max.
VDDIN_3V3	DC Supply	–	3.0V	3.3V	3.6V
	Maximum Input Current	–	–	–	450mA
VDDBU	DC Supply	Must be established first or at the same time as VDDIN_3V3.	1.65V	3.3V	3.6V
	Maximum Input Current	–	–	–	0.1 mA
VDDSDHC	DC Supply	SDHC I/Os Lines	1.65V	3.3V	3.6V
	Maximum Input Current	–	–	–	30mA

.....continued

Pad	Parameters	Conditions	Min.	Typ.	Max.
VDDISC	DC Supply	ISC I/Os Lines	1.65V	3.3V	3.6V
	Maximum Input Current	–	–	–	30mA

9.3 DC Electrical Characteristics

9.3.1 Standard Interfaces

The following characteristics are applicable to the operating temperature range $T_A = -40^{\circ}\text{C}$ to $+85^{\circ}\text{C}$, unless otherwise specified.

Table 9-3. DC Electrical Characteristics for GPIO Inputs

Pad	Parameters	Conditions	Min.	Typ.	Max.
V_{IL}	Low-level Input Voltage	All GPIO @ 3.3V	-0.3V	–	0.4V
V_{IH}	High-level Input Voltage	All GPIO @ 3.3V	2.3V	–	3.6V
V_{OL}	Low-level Output Voltage	I_O Max.	–	–	0.41V
V_{OH}	High-level Output Voltage	I_O Max.	2.9V	–	--
I_{IL}	Low-level Input Current	All GPIO @ 3.3V	-1 μ A	–	1 μ A
I_{IH}	High-level Input Current	All GPIO @ 3.3V	-1 μ A	–	1 μ A
I_{OL}	Low-level Output Current	All GPIO @ 3.3V / Low	-2mA	–	--
		All GPIO @ 3.3V / High	-32mA	–	--
I_{OH}	High-level Output Current	All GPIO @ 3.3V / Low	–	–	2mA
		All GPIO @ 3.3V / High	–	–	32mA
R_{PULLUP}	Pull-up Resistors	All GPIO @ 3.3V and PDxx in AD mode.	280k Ω	380k Ω	480k Ω
		All IOs in GPIO mode @3.3V.	40k Ω	66k Ω	130k Ω
$R_{PULLDOWN}$	Pull-down Resistors	All GPIO @ 3.3V and PDxx in AD mode	280 k Ω	380k Ω	480k Ω
		All IOs in GPIO mode @3.3V.	40k Ω	77k Ω	160k Ω

Note: This table applies to all the following pads: PA0–PA31, PB0–PB31, PC0–PC31, PD0–PD8, PD19–PD30.

9.3.2 Other PIOs

The following characteristics are applicable to the operating temperature range $T_A = -40^{\circ}\text{C}$ to $+85^{\circ}\text{C}$, unless otherwise specified.

SAMA5D27 SOM1

Electrical Characteristics

Table 9-4. Table 7. DC Electrical Characteristics for System Inputs

Pad	Parameters	Conditions	Min.	Typ.	Max.
V _{IL}	Low-level Input Voltage	DIS_BOOT	–	–	1.0V
V _{IH}	High-level Input Voltage	DIS_BOOT	2.3V	–	–

10. Mechanical Characteristics

10.1 Module Dimensions

The SAMA5D27 SOM1 has dimensions of 40mm x 38mm with specific mechanical characteristics listed below.

Figure 10-1. System-On-Module Dimensions

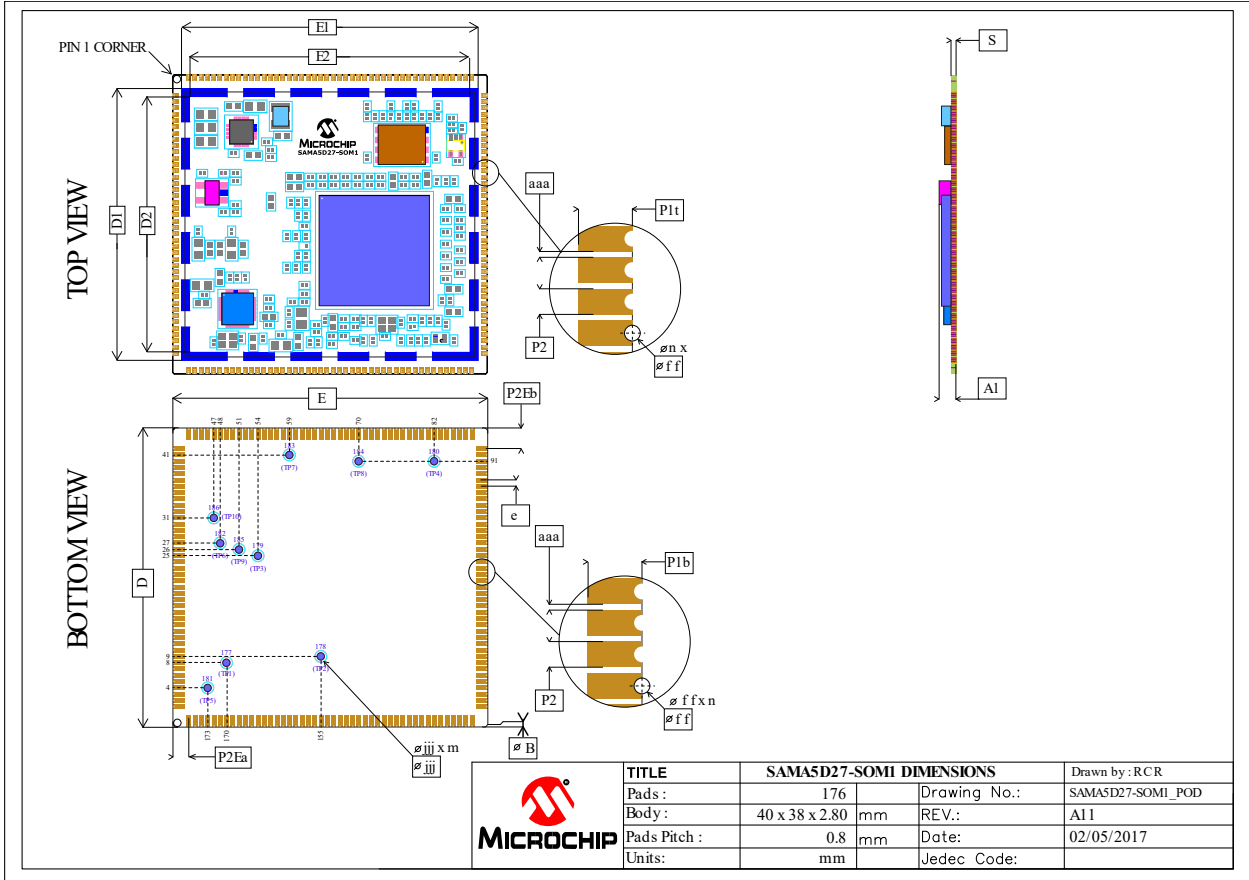

Table 10-1. System-On-Module Dimensions

	Symbol	Symbol	Common Dimensions			Comments
			Min.	Typ.	Max.	
Body Size	X	E	--	40.000	40.100	--
	Y	D	--	38.000	38.100	--
Pad Pitch		e	--	0.800	--	--
PCB Thickness		S	1.150	1.200	1.250	--
Total Thickness		A1	--	2.750	2.800	--
PCB Angle Hole Diameter ⁽¹⁾		B	--	0.200	--	--
Pad Length ⁽¹⁾	Bottom Side	P1b	--	1.500	--	--
	Top Side	P1t	--	0.800	--	--

SAMA5D27 SOM1

Mechanical Characteristics

.....continued						
		Symbol	Common Dimensions			Comments
			Min.	Typ.	Max.	
Pad Width ⁽¹⁾		P2	–	0.600	–	Solder Mask defined 0.550
Pad Space ⁽¹⁾		aaa	–	0.200	–	–
Opening Drilling Diameter		φff	–	0.400	–	0.400 typic minus metallization
Pad Count		n	–	176	–	–
Edge Center to Center	X	E1	37.550	37.630	37.700	–
	Y	D1	34.400	34.480	34.550	–
	X	E2	35.550	35.630	35.700	–
	Y	D2	32.400	32.480	32.550	–
Pad Axis to Edge ⁽¹⁾	X	P2Ea	–	2.000	–	–
	Y	P2Eb	–	2.600	–	–

Note:

- Tolerances are defined upon:
 - IPC A600 - Class2
 - IPC 2615



Test points placed on the bottom side are used for factory test only. It is not possible to connect external devices on these test points.

10.2 Module Land Pattern

The SAMA5D27 SOM1 Module has the following recommended Land Pattern characteristics.

SAMA5D27 SOM1

Mechanical Characteristics

Figure 10-2. System-On-Module Land Pattern

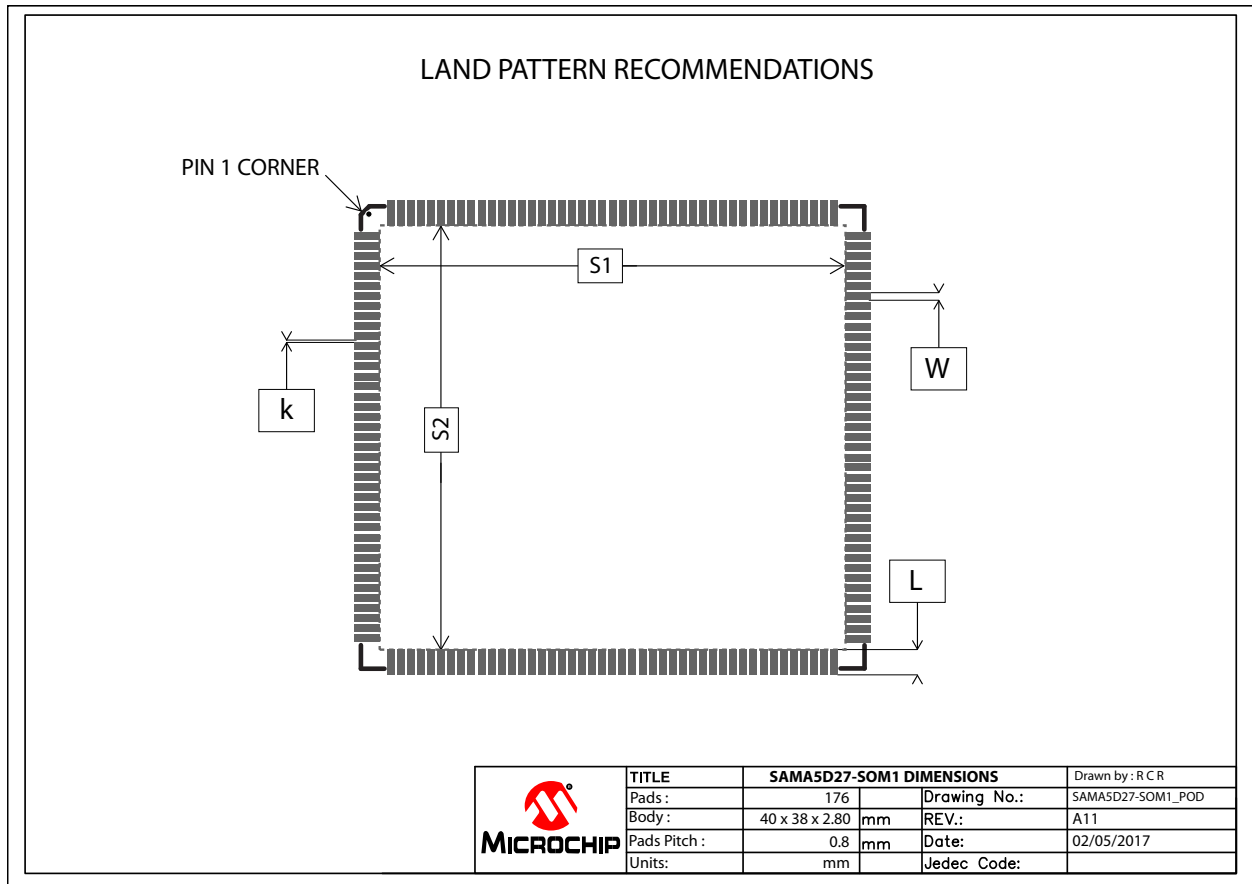

Do not place vias, copper or signals in the S1-S2 area on the top PCB layer of the motherboard. Copper and low-speed signals may be used on inner and opposite layers.

Table 10-2. System-On-Module Land Pattern Dimensions

	Symbol	Common Dimensions			Comments
		Min.	Typ.	Max.	
Land Pattern Pad Width	W	–	0.600	–	Solder Mask Defined 0.550
Land Pattern Pad Length	L	–	2.000	–	–
Land Pattern Pad X Space	S1	–	37.000	–	–
Land Pattern Pad Y Space	S2	–	35.000	–	–
Land Pattern Pad Space	k	–	0.200	–	–

11. Production Settings

11.1 Bake Information

The SAMA5D27-SOM1 module is rated MSL 3, indicating that storage and assembly processes must be compliant with IPC/JEDEC J-STD-033C.

The SAMA5D27-SOM1 module has a total thickness of 2.750 mm (PCB and SMD mounted) and is comparable to a die package. Thus baking instructions must comply with Table 4-1 of J-STD-033-C as a package body comprised between 2.0mm and 4.5mm.

Refer to the highlighted information in the table below.

IPC/JEDEC J-STD-033C

February 2012

Table 4-1 Reference Conditions for Drying Mounted or Unmounted SMD Packages (User Bake: Floor life begins counting at time = 0 after bake)

Package Body	Level	Bake @ 125 °C +10/-0 °C		Bake @ 90 °C +8/-0 °C ≤5% RH		Bake @ 40 °C +5/-0 °C ≤5% RH	
		Exceeding Floor Life by >72 h	Exceeding Floor Life by ≤72 h	Exceeding Floor Life by >72 h	Exceeding Floor Life by ≤72 h	Exceeding Floor Life by >72 h	Exceeding Floor Life by ≤72 h
Thickness ≤1.4 mm	2	5 hours	3 hours	17 hours	11 hours	8 days	5 days
	2a	7 hours	5 hours	23 hours	13 hours	9 days	7 days
	3	9 hours	7 hours	33 hours	23 hours	13 days	9 days
	4	11 hours	7 hours	37 hours	23 hours	15 days	9 days
	5	12 hours	7 hours	41 hours	24 hours	17 days	10 days
	5a	16 hours	10 hours	54 hours	24 hours	22 days	10 days
Thickness >1.4 mm ≤2.0 mm	2	18 hours	15 hours	63 hours	2 days	25days	20 days
	2a	21 hours	16 hours	3 days	2 days	29 days	22 days
	3	27 hours	17 hours	4 days	2 days	37 days	23 days
	4	34 hours	20 hours	5 days	3 days	47 days	28 days
	5	40 hours	25 hours	6 days	4 days	57 days	35 days
	5a	48 hours	40 hours	8 days	6 days	79 days	56 days
Thickness >2.0 mm ≤4.5 mm	2	48 hours	48 hours	10 days	7 days	79 days	67 days
	2a	48 hours	48 hours	10 days	7 days	79 days	67 days
	3	48 hours	48 hours	10 days	8 days	79 days	67 days
	4	48 hours	48 hours	10 days	10 days	79 days	67 days
	5	48 hours	48 hours	10 days	10 days	79 days	67 days
	5a	48 hours	48 hours	10 days	10 days	79 days	67 days
BGA package >17 mm x 17 mm or any stacked die package	2-5a	96 hours (See Note 2)	As above per package thickness and moisture level	Not applicable	As above per package thickness and moisture level	Not applicable	As above per package thickness and moisture level

Note 1: Table 4-1 is based on worst-case molded lead frame SMD packages. Users may reduce the actual bake time if technically justified (e.g., absorption/desorption data, etc.). In most cases it is applicable to other nonhermetic surface mount SMD packages. If parts have been exposed to >60% RH it may be necessary to increase the bake time by tracking desorption data to ensure parts are dry.

Note 2: For BGA packages >17 mm x 17 mm, that do not have internal planes that block the moisture diffusion path in the substrate, may use bake times based on the thickness/moisture level portion of the table.

Note 3: If baking of packages >4.5 mm thick is required see appendix B.

11.2 Reflow Profile

The SAMA5D27 SOM1 was assembled using standard lead-free reflow profile IPC/JEDEC J-STD-020E. We recommend a maximum of two soldering processes.

SAMA5D27 SOM1

Production Settings

The SAMA5D27 SOM1 can be soldered to the host PCB by using the standard and lead-free solder reflow profile. To avoid damage to the module, follow the JEDEC recommendations as well as those listed below:

- Do not exceed the peak temperature (T_p) of 245°C.
- Refer to the solder paste data sheet for specific reflow profile recommendations.
- Use no-clean flux solder paste.
- Use only one flow. If the PCB requires multiple flows, mount the module at the time of the final flow.

Figure 11-1. Reflow Profile Example used for Soldering SAMA5D27 SOM1 Module on SAMA5D27-SOM1-EK1 Board

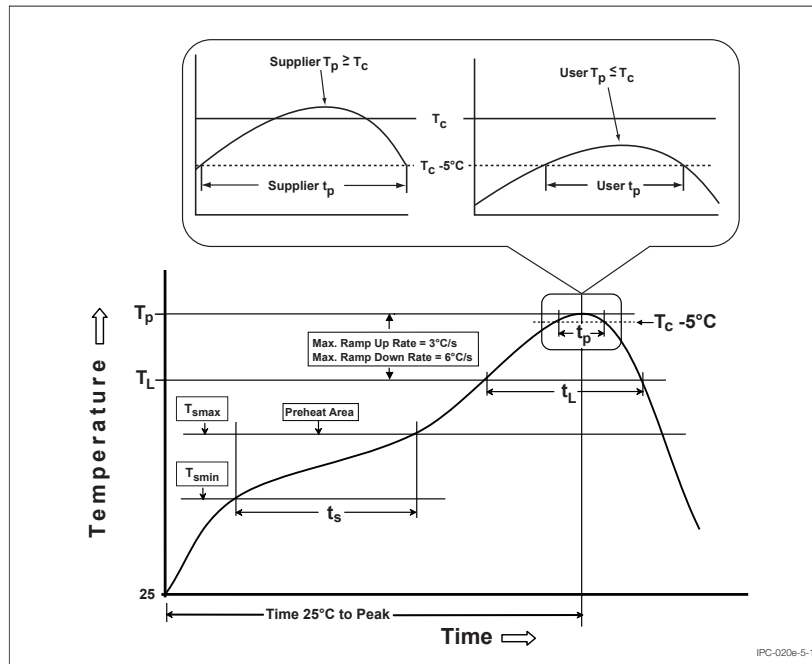

Profile Feature		J-STD-020E Profile
Temperature Min	T_{smin}	150°C
Temperature Max	T_{smax}	200°C
Temperature Rise	t_s (from T_{smin} to T_{smax})	60 to 120 seconds
Ramp-up Rate	T_L to T_p	3°C/sec.max
Liquidous Temperature Time maintained above 217°C	T_L	60 to 150 seconds
Peak Temperature	T_p	245°C
Time (t_p) within 5°C of the specified classification temperature (T_c)		30 seconds
Ramp-down rate	T_p to T_L	6°C/second max
Time 25°C to peak temperature		8 minutes max

12. Ordering Information

Table 12-1. Ordering Information

Ordering Code	Version	Package	Carrier Type	Operating Temperature Range
ATSAMA5D27-SOM1	1	176-pin 38x40mm	Tray	-40°C to +85°C

13. Revision History

Table 13-1. SAMA5D27 SOM1 Data Sheet, Rev. DS60001521D, June-2020

Changes
Description and Block Diagram : updated number of ADC inputs. Pinout Overview : updated figure.
Pin List : updated PIO muxing tables for PIOA, PIOB, PIOC and PIOD.
Table Other GPIO Possibilities for QSPI Interface in Case of Non-use : updated primary signal column.
Table External Memory Connections : updated eMMC and NAND Flash.

Table 13-2. SAMA5D27 SOM1 Data Sheet, Rev. DS60001521C, Oct-2018

Changes
Deleted all references to PTC in Features , Block Diagram , Pinout Overview and Pin List . Editorial corrections throughout.

Table 13-3. SAMA5D27 SOM1 Data Sheet, Rev. DS60001521B, Feb-2018

Changes
Features : added PTC support and LCD interface.
Applications : updated list.
1. Description : added PTC support.
2. Reference Documents : corrected datasheet cross-reference.
Pinout Overview : updated figure with correct color key.
SAMA5D27C-D1G-CU Supplies Decoupling Schematic : updated all occurrences of 1V2 to 1V25.
5.1 SAMA5D27 System-In-Package : removed table "SAMA5D27C-D1G-CU External Crystal".
5.2 Power Supplies : LDO1 output changed to 1.25V
5.4 Ethernet PHY : removed table "KSZ8081RNAIA External Crystal".
QSPI Memory Schematic : updated QSPI memory reference.
5.6 EEPROM Memory : updated Important Note .
10.2 Module Land Pattern : added Warning.
Added 11. Production Settings .
Updated 11.2 Reflow Profile .
Updated 12. Ordering Information .

Table 13-4. SAMA5D27 SOM1 Data Sheet, Rev. DS60001521A, Oct-2017

Changes
First issue.

The Microchip Website

Microchip provides online support via our website at www.microchip.com/. This website is used to make files and information easily available to customers. Some of the content available includes:

- **Product Support** – Data sheets and errata, application notes and sample programs, design resources, user's guides and hardware support documents, latest software releases and archived software
- **General Technical Support** – Frequently Asked Questions (FAQs), technical support requests, online discussion groups, Microchip design partner program member listing
- **Business of Microchip** – Product selector and ordering guides, latest Microchip press releases, listing of seminars and events, listings of Microchip sales offices, distributors and factory representatives

Product Change Notification Service

Microchip's product change notification service helps keep customers current on Microchip products. Subscribers will receive email notification whenever there are changes, updates, revisions or errata related to a specified product family or development tool of interest.

To register, go to www.microchip.com/pcn and follow the registration instructions.

Customer Support

Users of Microchip products can receive assistance through several channels:

- Distributor or Representative
- Local Sales Office
- Embedded Solutions Engineer (ESE)
- Technical Support

Customers should contact their distributor, representative or ESE for support. Local sales offices are also available to help customers. A listing of sales offices and locations is included in this document.

Technical support is available through the website at: www.microchip.com/support

Product Identification System

To order or obtain information, e.g., on pricing or delivery, refer to the factory or the listed sales office.

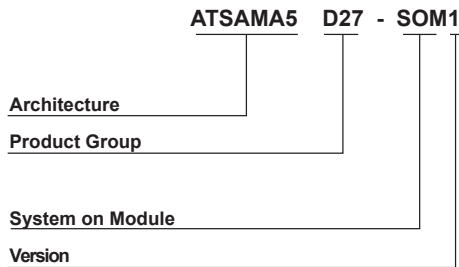

Architecture:	SAMA5
Product Group:	D27
System on Module:	SOM
Version:	1

Microchip Devices Code Protection Feature

Note the following details of the code protection feature on Microchip devices:

- Microchip products meet the specification contained in their particular Microchip Data Sheet.
- Microchip believes that its family of products is one of the most secure families of its kind on the market today, when used in the intended manner and under normal conditions.
- There are dishonest and possibly illegal methods used to breach the code protection feature. All of these methods, to our knowledge, require using the Microchip products in a manner outside the operating specifications contained in Microchip's Data Sheets. Most likely, the person doing so is engaged in theft of intellectual property.
- Microchip is willing to work with the customer who is concerned about the integrity of their code.
- Neither Microchip nor any other semiconductor manufacturer can guarantee the security of their code. Code protection does not mean that we are guaranteeing the product as "unbreakable."

Code protection is constantly evolving. We at Microchip are committed to continuously improving the code protection features of our products. Attempts to break Microchip's code protection feature may be a violation of the Digital Millennium Copyright Act. If such acts allow unauthorized access to your software or other copyrighted work, you may have a right to sue for relief under that Act.

Legal Notice

Information contained in this publication regarding device applications and the like is provided only for your convenience and may be superseded by updates. It is your responsibility to ensure that your application meets with your specifications. MICROCHIP MAKES NO REPRESENTATIONS OR WARRANTIES OF ANY KIND WHETHER EXPRESS OR IMPLIED, WRITTEN OR ORAL, STATUTORY OR OTHERWISE, RELATED TO THE INFORMATION, INCLUDING BUT NOT LIMITED TO ITS CONDITION, QUALITY, PERFORMANCE, MERCHANTABILITY OR FITNESS FOR PURPOSE. Microchip disclaims all liability arising from this information and its use. Use of Microchip devices in life support and/or safety applications is entirely at the buyer's risk, and the buyer agrees to defend, indemnify and hold harmless Microchip from any and all damages, claims, suits, or expenses resulting from such use. No licenses are conveyed, implicitly or otherwise, under any Microchip intellectual property rights unless otherwise stated.

Trademarks

The Microchip name and logo, the Microchip logo, Adaptec, AnyRate, AVR, AVR logo, AVR Freaks, BesTime, BitCloud, chipKIT, chipKIT logo, CryptoMemory, CryptoRF, dsPIC, FlashFlex, flexPWR, HELDO, IGLOO, JukeBlox, KeeLoq, Klear, LANCheck, LinkMD, maXStylus, maXTouch, MediaLB, megaAVR, Microsemi, Microsemi logo, MOST, MOST logo, MPLAB, OptoLyzer, PackeTime, PIC, picoPower, PICSTART, PIC32 logo, PolarFire, Prochip Designer, QTouch, SAM-BA, SenGenuity, SpyNIC, SST, SST Logo, SuperFlash, Symmetricom, SyncServer, Tachyon, TempTrackr, TimeSource, tinyAVR, UNI/O, Vectron, and XMEGA are registered trademarks of Microchip Technology Incorporated in the U.S.A. and other countries.

APT, ClockWorks, The Embedded Control Solutions Company, EtherSynch, FlashTec, Hyper Speed Control, HyperLight Load, IntelliMOS, Libero, motorBench, mTouch, Powermite 3, Precision Edge, ProASIC, ProASIC Plus, ProASIC Plus logo, Quiet-Wire, SmartFusion, SyncWorld, Temux, TimeCesium, TimeHub, TimePictra, TimeProvider, Vite, WinPath, and ZL are registered trademarks of Microchip Technology Incorporated in the U.S.A.

Adjacent Key Suppression, AKS, Analog-for-the-Digital Age, Any Capacitor, AnyIn, AnyOut, BlueSky, BodyCom, CodeGuard, CryptoAuthentication, CryptoAutomotive, CryptoCompanion, CryptoController, dsPICDEM, dsPICDEM.net, Dynamic Average Matching, DAM, ECAN, EtherGREEN, In-Circuit Serial Programming, ICSP, INICnet, Inter-Chip Connectivity, JitterBlocker, KlearNet, KlearNet logo, memBrain, Mindi, MiWi, MPASM, MPF, MPLAB Certified logo, MPLIB, MPLINK, MultiTRAK, NetDetach, Omniscient Code Generation, PICDEM, PICDEM.net, PICkit, PICtail, PowerSmart, PureSilicon, QMatrix, REAL ICE, Ripple Blocker, SAM-ICE, Serial Quad I/O, SMART-I.S., SQI, SuperSwitcher, SuperSwitcher II, Total Endurance, TSHARC, USBCheck, VariSense, ViewSpan, WiperLock, Wireless DNA, and ZENA are trademarks of Microchip Technology Incorporated in the U.S.A. and other countries.

SQTP is a service mark of Microchip Technology Incorporated in the U.S.A.

The Adaptec logo, Frequency on Demand, Silicon Storage Technology, and Symmcom are registered trademarks of Microchip Technology Inc. in other countries.

GestIC is a registered trademark of Microchip Technology Germany II GmbH & Co. KG, a subsidiary of Microchip Technology Inc., in other countries.

All other trademarks mentioned herein are property of their respective companies.

© 2020, Microchip Technology Incorporated, Printed in the U.S.A., All Rights Reserved.

ISBN: 978-1-5224-6118-0

AMBA, Arm, Arm7, Arm7TDMI, Arm9, Arm11, Artisan, big.LITTLE, Cordio, CoreLink, CoreSight, Cortex, DesignStart, DynamIQ, Jazelle, Keil, Mali, Mbed, Mbed Enabled, NEON, POP, RealView, SecurCore, Socrates, Thumb, TrustZone, ULINK, ULINK2, ULINK-ME, ULINK-PLUS, ULINKpro, μ Vision, Versatile are trademarks or registered trademarks of Arm Limited (or its subsidiaries) in the US and/or elsewhere.

Quality Management System

For information regarding Microchip's Quality Management Systems, please visit www.microchip.com/quality.

Worldwide Sales and Service

AMERICAS	ASIA/PACIFIC	ASIA/PACIFIC	EUROPE
<p>Corporate Office 2355 West Chandler Blvd. Chandler, AZ 85224-6199 Tel: 480-792-7200 Tel: 480-792-7277 Technical Support: www.microchip.com/support Web Address: www.microchip.com</p> <p>Atlanta Duluth, GA Tel: 678-957-9614 Fax: 678-957-1455</p> <p>Austin, TX Tel: 512-257-3370</p> <p>Boston Westborough, MA Tel: 774-760-0087 Fax: 774-760-0088</p> <p>Chicago Itasca, IL Tel: 630-285-0071 Fax: 630-285-0075</p> <p>Dallas Addison, TX Tel: 972-818-7423 Fax: 972-818-2924</p> <p>Detroit Novi, MI Tel: 248-848-4000</p> <p>Houston, TX Tel: 281-894-5983</p> <p>Indianapolis Noblesville, IN Tel: 317-773-8323 Fax: 317-773-5453 Tel: 317-536-2380</p> <p>Los Angeles Mission Viejo, CA Tel: 949-462-9523 Fax: 949-462-9608 Tel: 951-273-7800</p> <p>Raleigh, NC Tel: 919-844-7510</p> <p>New York, NY Tel: 631-435-6000</p> <p>San Jose, CA Tel: 408-735-9110 Tel: 408-436-4270</p> <p>Canada - Toronto Tel: 905-695-1980 Fax: 905-695-2078</p>	<p>Australia - Sydney Tel: 61-2-9868-6733</p> <p>China - Beijing Tel: 86-10-8569-7000</p> <p>China - Chengdu Tel: 86-28-8665-5511</p> <p>China - Chongqing Tel: 86-23-8980-9588</p> <p>China - Dongguan Tel: 86-769-8702-9880</p> <p>China - Guangzhou Tel: 86-20-8755-8029</p> <p>China - Hangzhou Tel: 86-571-8792-8115</p> <p>China - Hong Kong SAR Tel: 852-2943-5100</p> <p>China - Nanjing Tel: 86-25-8473-2460</p> <p>China - Qingdao Tel: 86-532-8502-7355</p> <p>China - Shanghai Tel: 86-21-3326-8000</p> <p>China - Shenyang Tel: 86-24-2334-2829</p> <p>China - Shenzhen Tel: 86-755-8864-2200</p> <p>China - Suzhou Tel: 86-186-6233-1526</p> <p>China - Wuhan Tel: 86-27-5980-5300</p> <p>China - Xian Tel: 86-29-8833-7252</p> <p>China - Xiamen Tel: 86-592-2388138</p> <p>China - Zhuhai Tel: 86-756-3210040</p>	<p>India - Bangalore Tel: 91-80-3090-4444</p> <p>India - New Delhi Tel: 91-11-4160-8631</p> <p>India - Pune Tel: 91-20-4121-0141</p> <p>Japan - Osaka Tel: 81-6-6152-7160</p> <p>Japan - Tokyo Tel: 81-3-6880-3770</p> <p>Korea - Daegu Tel: 82-53-744-4301</p> <p>Korea - Seoul Tel: 82-2-554-7200</p> <p>Malaysia - Kuala Lumpur Tel: 60-3-7651-7906</p> <p>Malaysia - Penang Tel: 60-4-227-8870</p> <p>Philippines - Manila Tel: 63-2-634-9065</p> <p>Singapore Tel: 65-6334-8870</p> <p>Taiwan - Hsin Chu Tel: 886-3-577-8366</p> <p>Taiwan - Kaohsiung Tel: 886-7-213-7830</p> <p>Taiwan - Taipei Tel: 886-2-2508-8600</p> <p>Thailand - Bangkok Tel: 66-2-694-1351</p> <p>Vietnam - Ho Chi Minh Tel: 84-28-5448-2100</p>	<p>Austria - Wels Tel: 43-7242-2244-39 Fax: 43-7242-2244-393</p> <p>Denmark - Copenhagen Tel: 45-4485-5910 Fax: 45-4485-2829</p> <p>Finland - Espoo Tel: 358-9-4520-820</p> <p>France - Paris Tel: 33-1-69-53-63-20 Fax: 33-1-69-30-90-79</p> <p>Germany - Garching Tel: 49-8931-9700</p> <p>Germany - Haan Tel: 49-2129-3766400</p> <p>Germany - Heilbronn Tel: 49-7131-72400</p> <p>Germany - Karlsruhe Tel: 49-721-625370</p> <p>Germany - Munich Tel: 49-89-627-144-0 Fax: 49-89-627-144-44</p> <p>Germany - Rosenheim Tel: 49-8031-354-560</p> <p>Israel - Ra'anana Tel: 972-9-744-7705</p> <p>Italy - Milan Tel: 39-0331-742611 Fax: 39-0331-466781</p> <p>Italy - Padova Tel: 39-049-7625286</p> <p>Netherlands - Druenen Tel: 31-416-690399 Fax: 31-416-690340</p> <p>Norway - Trondheim Tel: 47-72884388</p> <p>Poland - Warsaw Tel: 48-22-3325737</p> <p>Romania - Bucharest Tel: 40-21-407-87-50</p> <p>Spain - Madrid Tel: 34-91-708-08-90 Fax: 34-91-708-08-91</p> <p>Sweden - Gothenberg Tel: 46-31-704-60-40</p> <p>Sweden - Stockholm Tel: 46-8-5090-4654</p> <p>UK - Wokingham Tel: 44-118-921-5800 Fax: 44-118-921-5820</p>