

THESE DRAWINGS ARE THE PROPERTY OF QUALTEK ELECTRONICS AND NOT TO BE REPRODUCED FOR OR COMMUNICATED TO A THIRD PARTY WITHOUT THE EXPRESS WRITTEN PERMISSION OF AN OFFICER OF QUALTEK ELECTRONICS.

| REVISION |                            |          |          |
|----------|----------------------------|----------|----------|
| REV.     | DESCRIPTION                | DATE     | APPROVED |
| B        | Updated Notes and Graphics | 11-18-15 | LY       |
|          |                            |          |          |

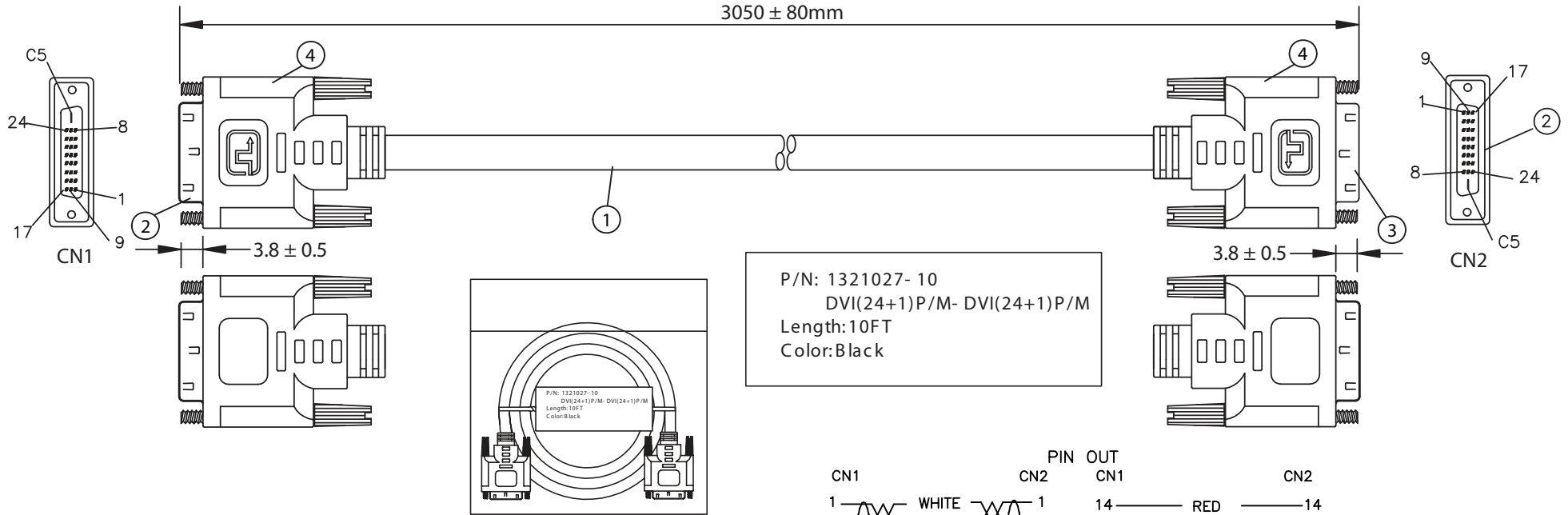

P/N: 1321027- 10  
 DVI(24+1)P/M- DVI(24+1)P/M  
 Length: 10FT  
 Color: Black

NOTES:

- CABLE: UL20276  
 (28AWG\*1PR+EAM)\*7+28AWG\*1PR+28AWG\*3C+AEB(AL) 65%  
 OUTER JACKET: BLACK, OD: 8.5 ± 0.2mm
- CONNECTOR: DVI 24+1 MALE  
 INSULATOR: BLACK  
 PIN G/F  
 NICKEL PLATED SHELL  
 THUMB SCREW: 2.8\*32.5mm 4-40UNC
- CONNECTOR: DVI 24+1 MALE  
 INSULATOR: BLACK  
 PIN G/F  
 NICKEL PLATED SHELL  
 THUMB SCREW: 2.8\*32.5mm 4-40UNC
- PVC MOLDED: COLOR V398 30P BLACK
- ELECTRICAL TEST:  
 <1>.100% OPEN SHORT & MISS WIRE TEST  
 <2>.INSULATION RESISTANCE: AC300V DC400V 10M ohm MIN.  
 <3>.CONDUCTOR RESISTANCE: 3 ohm MAX.
- PACKING: 1PC/POLYBAG

| CN1 |        | CN2 |        | PIN OUT |               | CN1   |               | CN2   |               |
|-----|--------|-----|--------|---------|---------------|-------|---------------|-------|---------------|
| 1   | WHITE  | 1   | WHITE  | 14      | RED           | 14    | RED           | 14    | RED           |
| 2   | GREEN  | 2   | GREEN  | 15      | VIOLET        | 15    | VIOLET        | 15    | VIOLET        |
| 3   | DRAIN  | 3   | DRAIN  | 16      | WHITE         | 16    | WHITE         | 16    | WHITE         |
| 4   | DRAIN  | 4   | DRAIN  | 17      | PINK          | 17    | PINK          | 17    | PINK          |
| 5   | BLUE   | 5   | BLUE   | 18      | ORANGE        | 18    | ORANGE        | 18    | ORANGE        |
| 6   | YELLOW | 6   | YELLOW | 19      | DRAIN         | 19    | DRAIN         | 19    | DRAIN         |
| 7   | ORANGE | 7   | ORANGE | 20      | DRAIN         | 20    | DRAIN         | 20    | DRAIN         |
| 9   | WHITE  | 9   | WHITE  | 21      | BLACK         | 21    | BLACK         | 21    | BLACK         |
| 10  | RED    | 10  | RED    | 22      | GRAY          | 22    | GRAY          | 22    | GRAY          |
| 11  | DRAIN  | 11  | DRAIN  | 23      | LIGHT-BLUE    | 23    | LIGHT-BLUE    | 23    | LIGHT-BLUE    |
| 12  | DRAIN  | 12  | DRAIN  | 24      | VIOLET        | 24    | VIOLET        | 24    | VIOLET        |
| 13  | BROWN  | 13  | BROWN  | SHELL   | BRAID & DRAIN | SHELL | BRAID & DRAIN | SHELL | BRAID & DRAIN |

**CONTROLLED**

| Dim range (mm) | Tolerance +/- (mm) | Qualtek Electronics Corp.<br>WCI DIVISION  |                |                 |
|----------------|--------------------|--|----------------|-----------------|
|                |                    | Part Number: 1321027-10                    | RoHS Compliant |                 |
| 0-1            | 0.15               | Description: DVI (24+1)P/M - DVI (24+1)P/M |                |                 |
| 1-6            | 0.20               |  | UNIT: mm       | REV. B          |
| 6-18           | 0.30               |  |                |                 |
| 18-50          | 0.50               |  |                |                 |
| 50-120         | 0.70               | Drawn / Date                               | Checked / Date | Approved / Date |
| 120-250        | 0.90               | B. Grubb<br>01-25-07                       | 01-25-07       | JJH / 01-25-07  |
| 250-500        | 1.20               |  |                |                 |