

DC Input Solid State Relay

PCS34 DC Input



FEATURES

- High Power Solid State Relay
- SCR Output
- Load Currents from 10 to 125 Amps
- Dielectric Strength of 4,000 VAC
- Optical Isolation between Input & Output

E93379



INPUT PARAMETERS (Ta = 30°C)

Control Voltage Range	4 ~ 32 VDC
Must Turn-On Voltage	4 VDC

Must Turn-Off Voltage	1 VDC
Max Input Current	25 mA
Max Reverse Protection Voltage	-32 VDC

OUTPUT CURRENT PARAMETERS (Ta = 30°C)

Load Current (200mA min)**	10A	25A	40A	50A	60A	70A	80A	100A	125A
Max Surge Current (10 ms, A _{pk})	100	250	400	500	600	700	800	1000	1200
Max I ² t (10 ms, A ² s)	200	500	800	1250	1800	2450	3200	3200	3200
Thermal Resistance Junction to Case (R _{jc} , °C/W)	0.35	0.35	0.25	0.20	0.20	0.14	0.14	0.14	0.13

**Minimum current loading over range required to fully turn on device. Standard UL endurance ratings are 6,000 cycles.

OUTPUT VOLTAGE PARAMETERS

	240A	380A	480A	600A
Load Voltage Range (VAC)	48~280	48~440	48~530	48~660
Max Transient Voltage (V _{pk})	600	800	1200	1400
Max Turn-On Time Random Zero Crossing	1 ms 1/2 cycle + 1 ms			
Max Off-State Leakage Current	10 mA			
Max On-State Voltage Drop	1.7 Vrms			
Min Power Factor	0.5			
Max Turn-Off Time	1/2 cycle + 1 ms			
Frequency Range	47 Hz to 63 Hz			
Min Off-State (dv/dt)	500 V/us			

CHARACTERISTICS

Dielectric Strength	2500 VAC, 1 min Input, Output to Base 4000 VAC, 1 min Input to Output
Insulation Resistance	1000MΩ at 500 VDC
Max Capacitance	8pF, Input to Output
Operating Temperature	-30°C to 80°C
Storage Temperature	-30°C to 100°C
Relative Humidity	45% ~ 85%
Weight	88g

Additional Part Specific UL Ratings

Control Voltage	Load Voltage	Output Current
Model PCS34-Dxxx-60-xxx		
4 ~ 32VDC with LED	240 VAC 50/60 Hz	3HP (17 FLA), 6K cycles, single phase
Model PCS34-D240A-50-xxx		
4 ~ 32VDC	240 VAC 50/60 Hz	11.8A, 65°C, 100K cycles, resistive
4 ~ 32VDC	280 VAC 50/60 Hz	50A, 65°C, 100K cycles, resistive

ORDERING INFORMATION

Example	PCS34	-D	-240A	-25	Z	L
Model:	PCS34					
Coil Voltage:	D = 4~32 VDC					
Load Voltage:	240A = 48~280VAC 380A = 48~440VAC 480A = 48~530VAC 600A = 48~660VAC ⁽²⁾					
Load Current:	10 = 10A ⁽¹⁾ 25 = 25A ⁽¹⁾ 40 = 40A 50 = 50A 60 = 60A 70 = 70A 80 = 80A 100 = 100A 125 = 125A ⁽³⁾					
Switching Type:	Z = Zero Crossing R = Random Turn-On / Instantaneous Turn-On ⁽⁴⁾					
Over Voltage Protection:	Nil = None Y = With Varistor (MOV)					
Status LED:	L = Indicator LED					
Terminal Type	Nil = Screw Terminal Q = Quick Connect (3/16" control, 1/4" power) ⁽⁵⁾					

- Notes:
 (1) Available in 240A and 380A load voltage
 (2) Zero Crossing only
 (3) Not UL recognized
 (4) Only available with 240V / 380V / 480V load voltages
 (5) Only available with 50A and below Load Currents

PRECAUTIONS

- When choosing a Solid State Relay (SSR), note the actual load current and ambient temperature and reference the Characteristic Curves.
- SSRs require an adequate heat sinking or other effective cooling measure.
- With ambient temperature above 25°C, refer to the curve of Max Load Current vs. Ambient Temperature for load current derating.
- Apply heat-conducting silicon grease or a thermal transfer pad on the space between the SSR and heat sink and screw the SSR firmly to the heat sink to avoid damage from overheating.
- Tighten the SSR terminal screws properly. We recommend screw installation torque as follows:
 M4 screw mounting torque range is (0.98~1.37)N * m
 M3 screw mounting torque range is (0.56~0.98)N * m
 Loose screws will damage the SSR with heat generated from connections. Also, excessive screw torque may damage the relay's internal components.
- It is recommended to use a heat sink matched to the Current Load. With any heat sink, test that the SSR base temperature does not exceed 65°C.
- When using the PCS34 relay with an inductive load, it is suggested to select Random Turn-On. (i.e. a model with "R" Switching Type)
- The PCS34 is not suitable for capacitive loads; if you must, then do not choose products with varistor protection. (i.e. a model with the "Y" Over Voltage Protection)
- Listed parameters are based on resistive loads. Do not use the relay beyond the described current, temperature, load or voltage limits as described in this datasheet.

DIMENSIONS

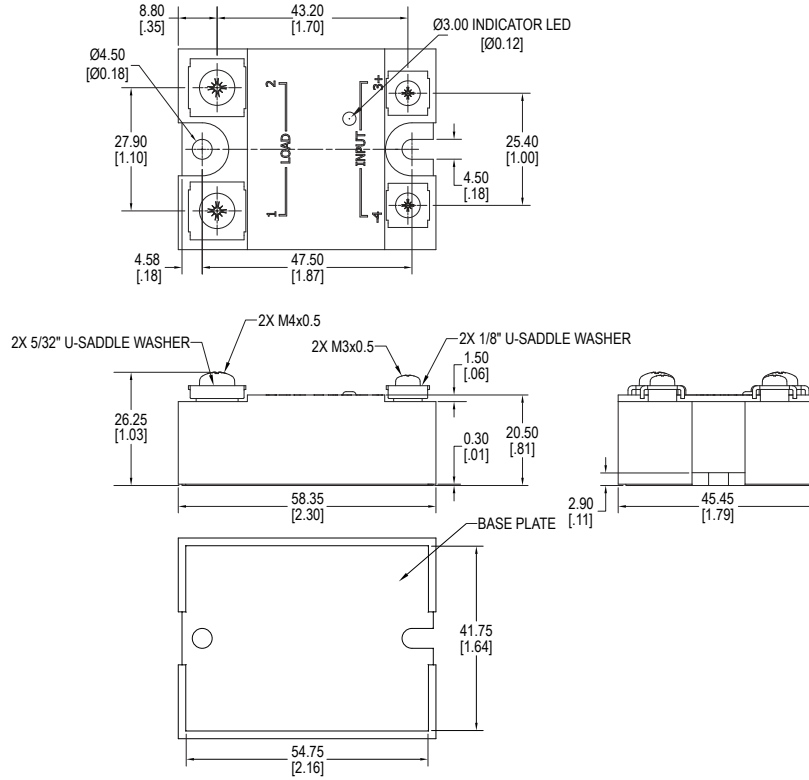

Screw Terminals

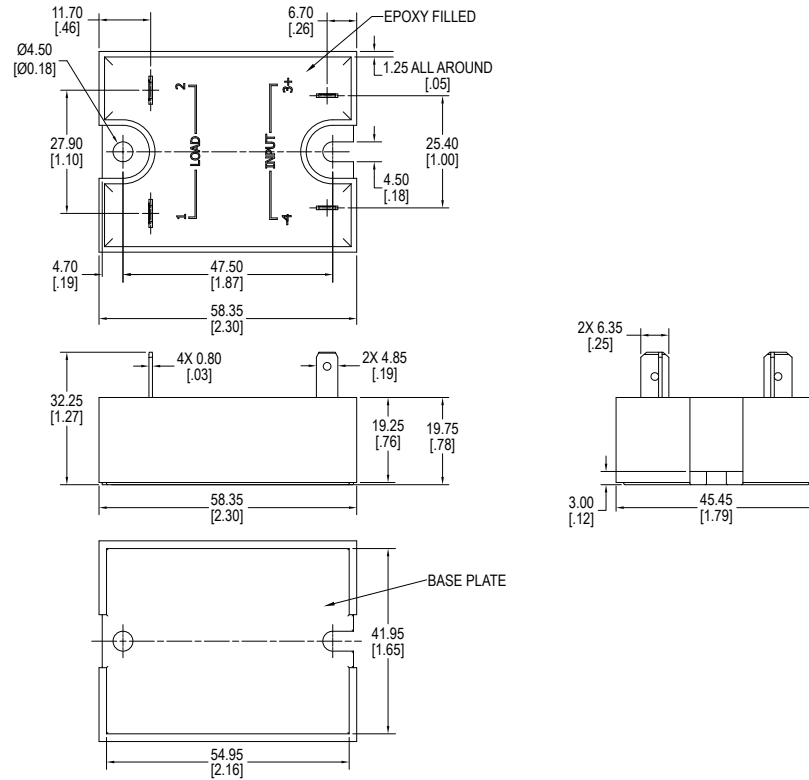

Quick Connect Terminals

DIMENSIONS — Continued

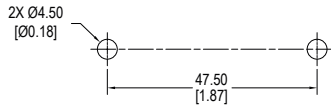

Mounting Layout

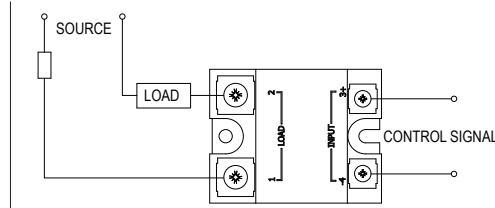

Wiring Diagram

CHARACTERISTIC CURVES

Max Load Current vs. Ambient Temperature (25A)

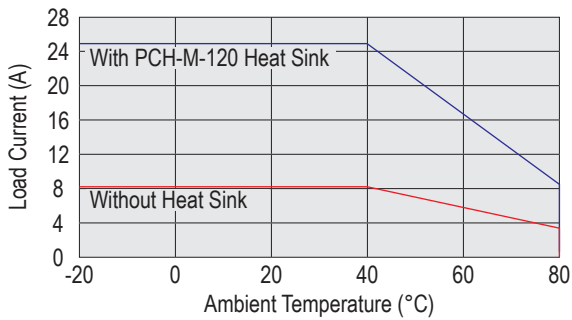

Max Load Current vs. Ambient Temperature (40A)

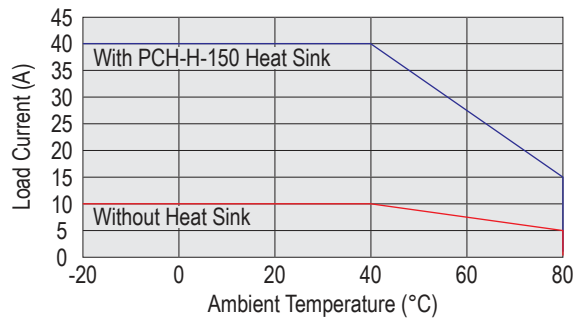

Max Load Current vs. Ambient Temperature (50A)

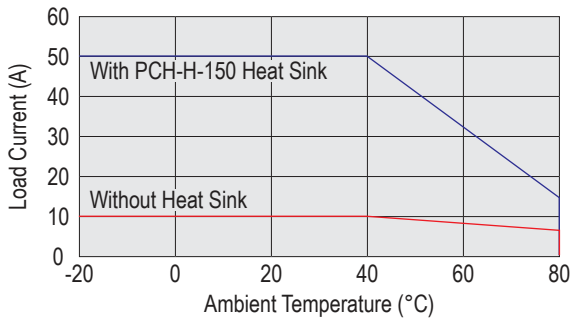

Max Load Current vs. Ambient Temperature (60A)

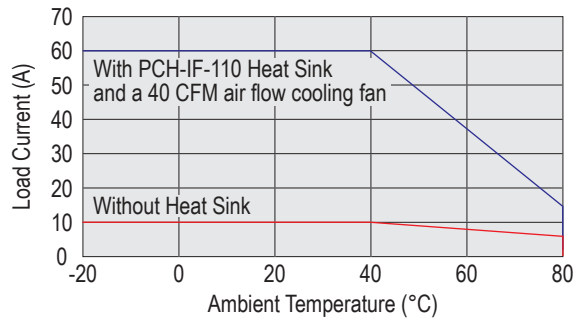

Max Load Current vs. Ambient Temperature (70A)

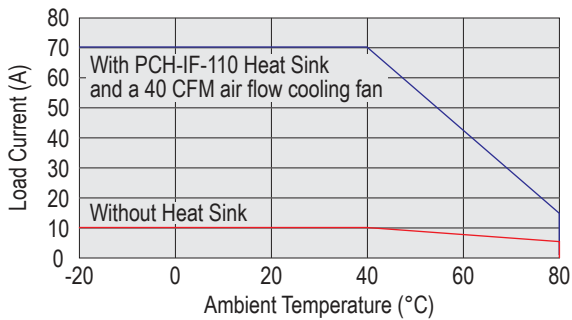

Max Load Current vs. Ambient Temperature (80A)

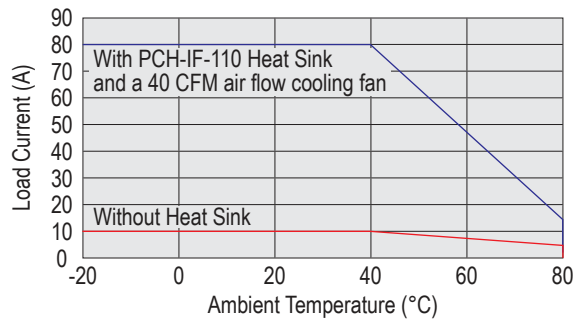

ACCESSORIES — Sold Separately

Heat Transfer Pad	HTP100
Protective Cover	SSR100
Heat Sinks	PCH-I-50 for application up to 25 Amps @ 25°C PCH-M-120 for application up to 35 Amps @ 25°C PCH-H-150 for application up to 50 Amps @ 25°C PCH-IF-100 for applications up to 60 Amps @ 25C (requires an additional 40 CFM cooling fan)



HTP100 — Heat Transfer Pad

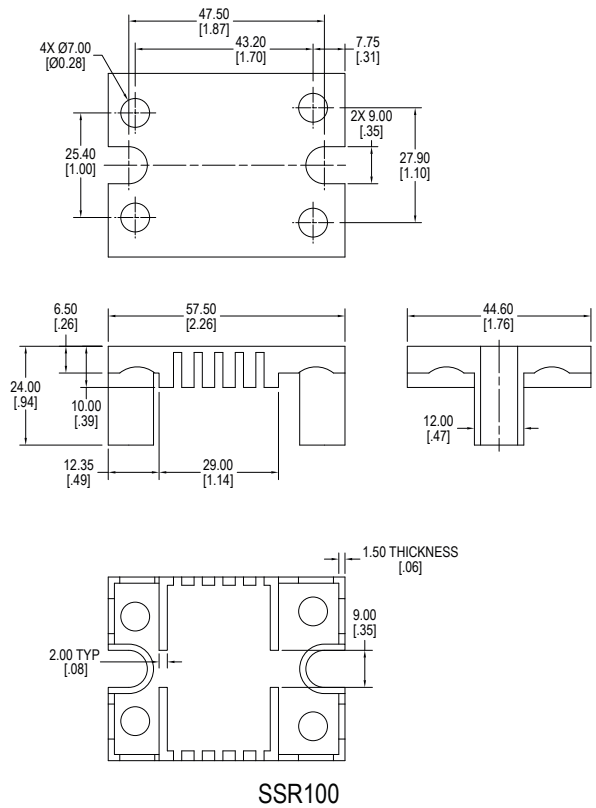

SSR100

ACCESSORIES — Sold Separately Continued

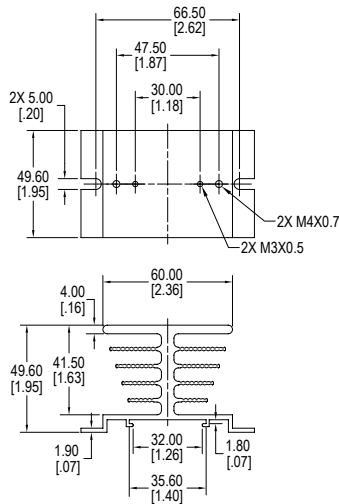

PCH-I-50 Heat Sink

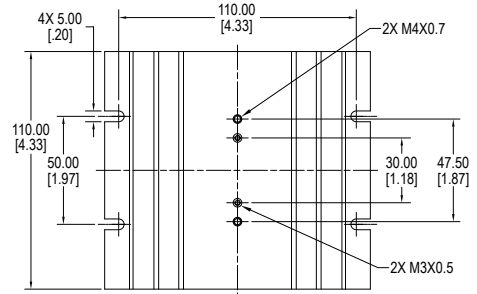

PCH-M-120 Heat Sink

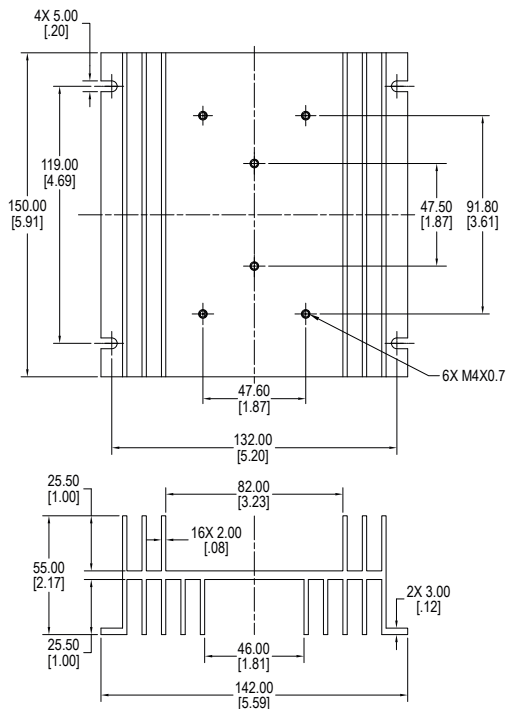

PCH-H-150 Heat Sink

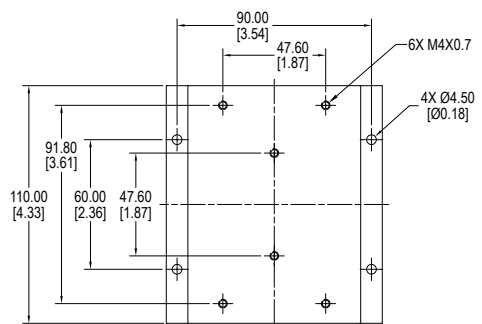

PCH-IF-110 Heat Sink