

MAXIM

LED Driver with Programmable Prebias Voltage

MAX3966

General Description

The MAX3966 is a programmable LED driver for fiber optic transmitters operating at data rates up to 266Mbps. The circuit contains a high-speed current driver with programmable temperature coefficient (tempco), adjustments for LED prebias voltage, and a V_{BB} reference voltage generator. The circuit accepts PECL data inputs, and operates from a single +3V to +5.5V power supply.

The MAX3966 can switch up to 100mA into typical high-speed light-emitting diodes. As temperature increases, the device's modulation current increases with a tempco that is programmable from 2500ppm/°C to 12,000ppm/°C. The modulation current is programmed with a single external resistor.

The MAX3966's LED prebias voltage is programmable from 400mV to 925mV. The prebias circuit produces peaking current, which improves the LED switching speed.

Complementary current outputs help to maintain a constant supply current, reducing EMI and supply noise generated by the transmitter module. The MAX3966 is available in die form, or in 16-pin and 24-pin QSOP packages.

Applications

Multimode LED Transmitters
FDDI
Fast Ethernet
155Mbps ATMs
ESCON
266Mbps Fibre Channel

Features

- ◆ Programmable LED Prebias Voltage
- ◆ Single +3V to +5.5V Power Supply
- ◆ Complementary Output Reduces Supply Noise
- ◆ Adjustable Modulation Current
- ◆ Adjustable Temperature Compensation
- ◆ Available in 16-Pin/24-Pin QSOP or Die

Ordering Information

PART	TEMP. RANGE	PIN-PACKAGE
MAX3966CEE*	0°C to +70°C	16 QSOP
MAX3966CEG	0°C to +70°C	24 QSOP
MAX3966C/D	0°C to +100°C**	Dice

*Some features are not available in the 16-pin QSOP package. Contact factory for information and availability.

**Dice are designed to operate over a 0°C to +100°C junction temperature (T_j) range, but are tested and guaranteed only at $T_A = +25^\circ\text{C}$.

Typical Operating Circuit

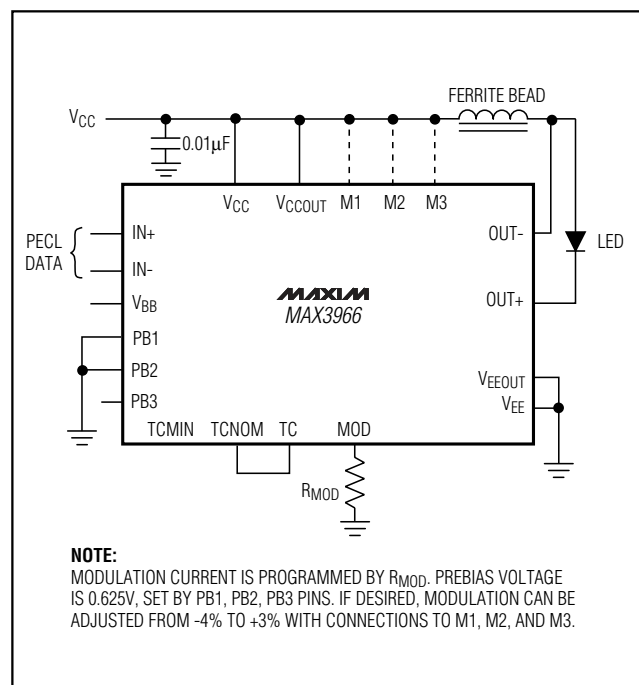

Pin Configurations appear at end of data sheet.

MAXIM

Maxim Integrated Products 1

For free samples and the latest literature, visit www.maxim-ic.com or phone 1-800-998-8800.
For small orders, phone 1-800-835-8769.

LED Driver with Programmable Prebias Voltage

ABSOLUTE MAXIMUM RATINGS

Supply Voltage at V_{CC} , V_{CCOUT} ($V_{EE} = 0V$)-0.5V to 7V
 Current into $OUT+$, $OUT-$ -40mA to 160mA
 Differential Output Voltage (V_{OUT+} to V_{OUT-})-3.3V to 3.3V
 Voltage at M1, M2, M3, PB1, PB2, PB3,
 $IN+$, $IN-$, $OUT+$, $OUT-$, V_{BB} -0.5V to ($V_{CC} + 0.5V$)
 Voltage at $TCMIN$, $TCNOM$, TC , MOD -0.5V to 2V

Continuous Power Dissipation ($T_A = +70^\circ C$)
 16-pin QSOP (derate 8.3mW/ $^\circ C$ above $+70^\circ C$)667mW/ $^\circ C$
 24-pin QSOP (derate 10mW/ $^\circ C$ above $+70^\circ C$)770mW/ $^\circ C$
 Operating Junction Temperature Range-50 $^\circ C$ to $+150^\circ C$
 Die Attach Temperature+400 $^\circ C$
 Storage Temperature Range-50 $^\circ C$ to $+150^\circ C$
 Lead Temperature (soldering, 10sec)+300 $^\circ C$

Stresses beyond those listed under "Absolute Maximum Ratings" may cause permanent damage to the device. These are stress ratings only, and functional operation of the device at these or any other conditions beyond those indicated in the operational sections of the specifications is not implied. Exposure to absolute maximum rating conditions for extended periods may affect device reliability.

DC ELECTRICAL CHARACTERISTICS

(Load as specified in Figure 1; $V_{CC} = 3.0V$ to $5.5V$, $V_{EE} = 0V$, $T_A = 0^\circ C$ to $+70^\circ C$, unless otherwise noted. Temperature coefficients are referenced to $T_A = +25^\circ C$. Typical values are at $T_A = +25^\circ C$, $V_{CC} = 3.3V$, unless otherwise noted. Dice are tested at $T_A = +25^\circ C$ only.)

PARAMETER	CONDITIONS	MIN	TYP	MAX	UNITS
Data Input High Voltage	Referenced to V_{CC}	-1.165		-0.880	V
Data Input Low Voltage	Referenced to V_{CC}	-1.810		-1.475	V
Supply Current	(Note 1)		30	35	mA
Input Current at $IN+$ or $IN-$		-50		50	μA
Maximum Programmable Modulation Current	(Note 2)	100	130		mA
Minimum Programmable Modulation Current				40	mA
Modulation-Current Accuracy	(Note 3)	-10		10	%
Prebias Voltage	PB1, PB2, PB3 = (open, open, open)	0.380	0.400	0.428	V
	PB1, PB2, PB3 = (V_{EE} , V_{EE} , open)	0.594	0.625	0.663	
	PB1, PB2, PB3 = (V_{EE} , V_{EE} , V_{EE})	0.879	0.925	0.981	
Temperature Coefficient of Modulation Current	Maximum tempco (TC open)		12,000		ppm/ $^\circ C$
	Nominal tempco (TC, $TCNOM$ shorted)		3600		
	Minimum tempco (TC, $TCMIN$ shorted)		2500		
V_{BB} Voltage	Referenced to V_{CC}	-1.38	-1.33	-1.26	V
Prebias Resistor ($R_{PREBIAS}$)		66.3	78	89.7	Ω

Note 1: $R_{MOD} = 1k\Omega$. Excludes I_{OUT+} and I_{OUT-} .

Note 2: $V_{CC} = 3.0V$. $R_{MOD} = 698\Omega$, TC connected to $TCMIN$.

Note 3: $V_{CC} = 3.3V$, $V_{LED} = 1.55V$, prebias voltage programmed at 0.625V (nominal), $T_A = +25^\circ C$. $R_{MOD} = 1k\Omega$, and programs approximately 80mA current. M1 = V_{CC} , M2 = open, M3 = open, TC connected to $TCNOM$.

LED Driver with Programmable Prebias Voltage

MAX3966

AC ELECTRICAL CHARACTERISTICS

(Load as specified in Figure 1, unless otherwise noted. $V_{CC} = 3.0V$ to $5.5V$, $R_{MOD} = 1k\Omega$, $T_A = 0^\circ C$ to $+70^\circ C$. Input data-edge speed = $1ns$ (typ), $V_{PREBIAS} = 0.625V$. Typical values are at $T_A = +25^\circ C$, $V_{CC} = 3.3V$, nominal tempco.)

PARAMETER	CONDITIONS	MIN	TYP	MAX	UNITS
Output Current Edge Speed	20% to 80%, input is a 12.5MHz square wave	400	615	1000	ps
Output Current Pulse-Width Correction (PWC)	Input is a 12.5MHz square wave (Note 4)		-210		ps
Output Current Data-Dependent Jitter	266Mbps (Note 5)		150		ps
	155Mbps (Note 6)		215	330	
Random Jitter	RMS		1.1		ps

Note 4: $PWC = (width_{CURRENT\ ON} - width_{CURRENT\ OFF}) / 2$.

Note 5: Test pattern is a 2 - 1PRBS transmitted at 266Mbps (3.75ns per bit).

Note 6: Test pattern is a 2^{13} - 1PRBS containing 72 consecutive zeros or 72 consecutive ones.

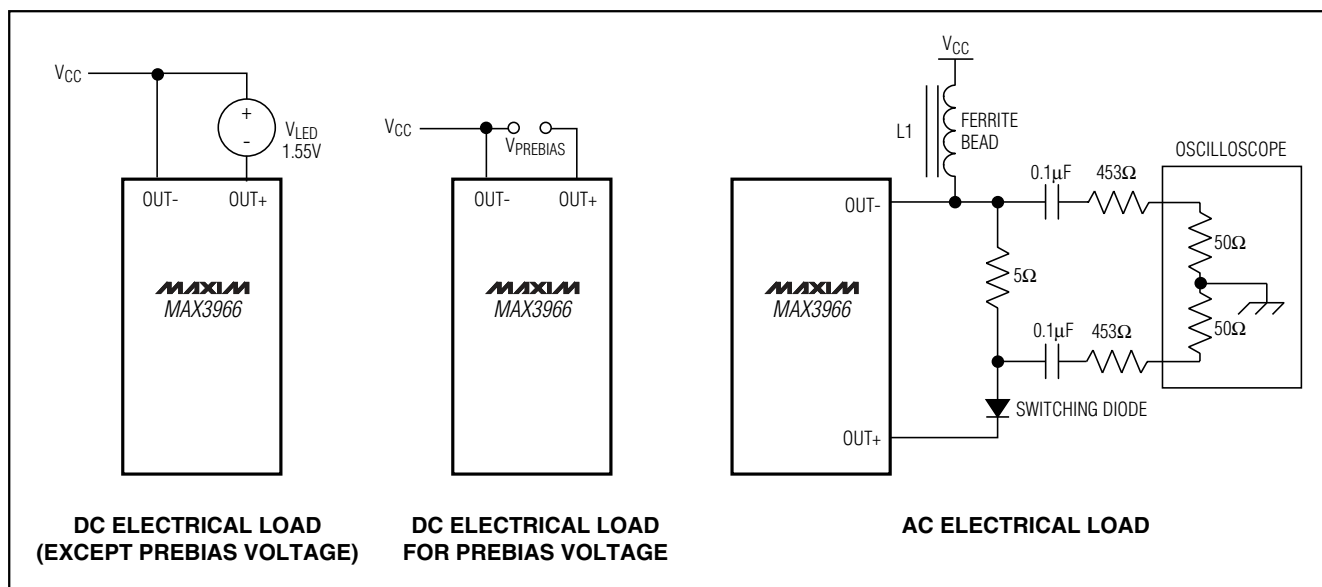
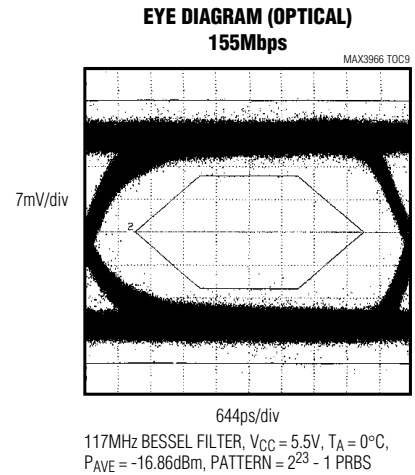
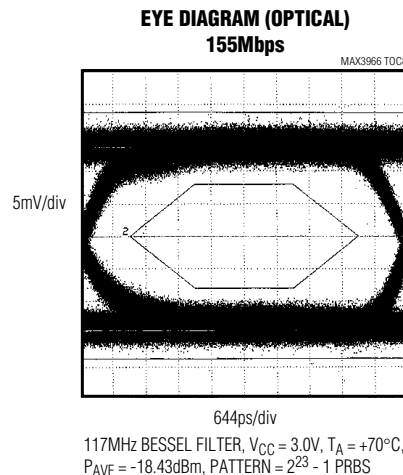
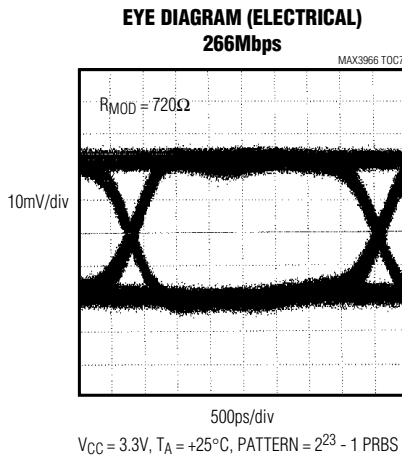
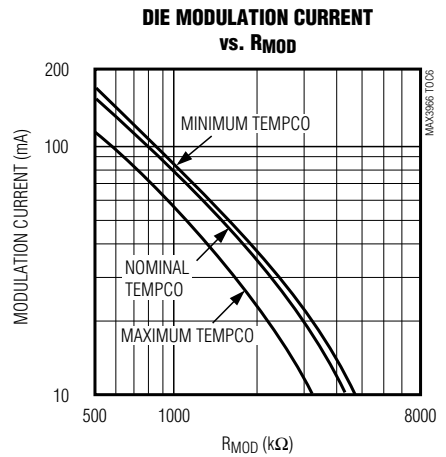
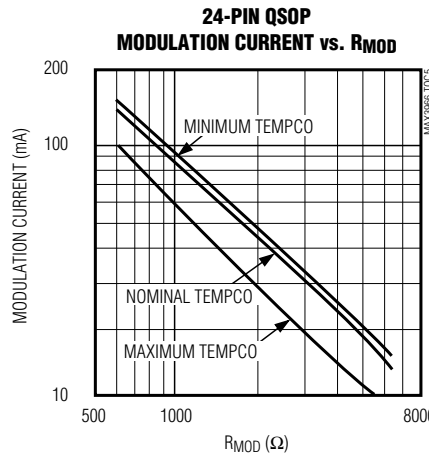
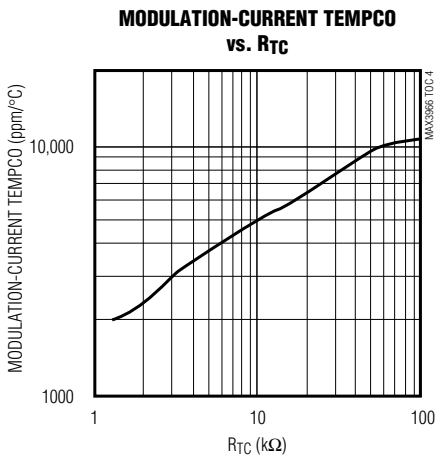
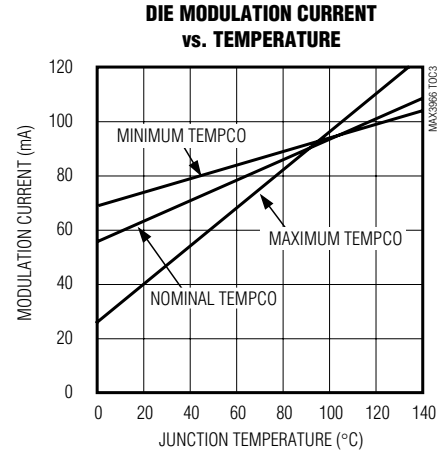
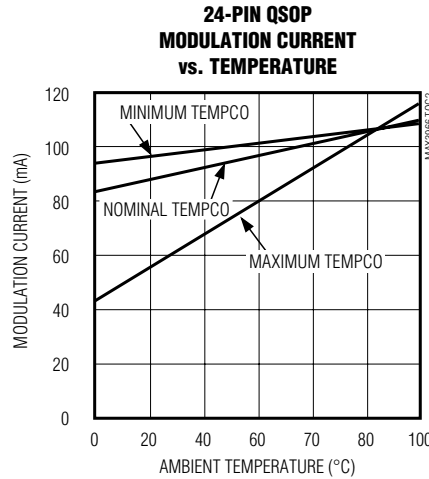
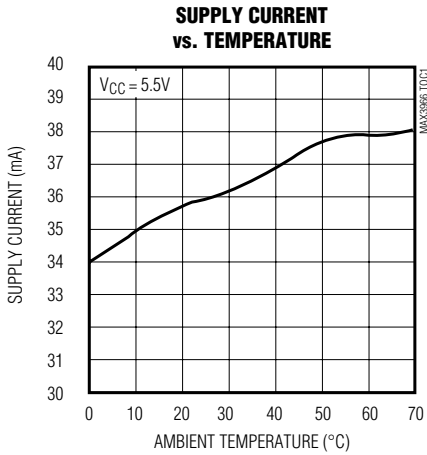

Figure 1. MAX3966 Output Test Loads

LED Driver with Programmable Prebias Voltage

Typical Operating Characteristics

(MAX3966CEG in Maxim evaluation board. $V_{CC} = 3.3V$, prebias voltage = 0.625V nominal tempco, $R_{MOD} = 1k\Omega$, $T_A = +25^\circ C$, unless otherwise noted.)



LED Driver with Programmable Prebias Voltage

Typical Operating Characteristics (continued)

(MAX3966CEG in Maxim evaluation board. $V_{CC} = 3.3V$, prebias voltage = 0.625V nominal tempco, $R_{MOD} = 1k\Omega$, $T_A = +25^\circ C$, unless otherwise noted.)

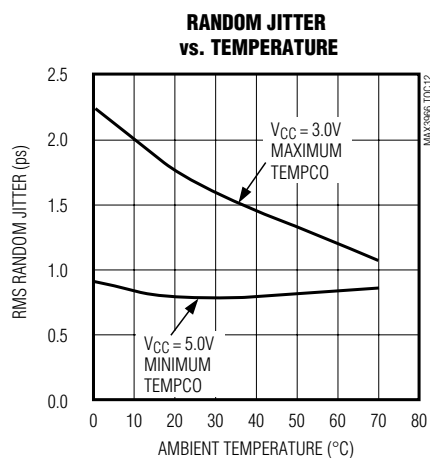
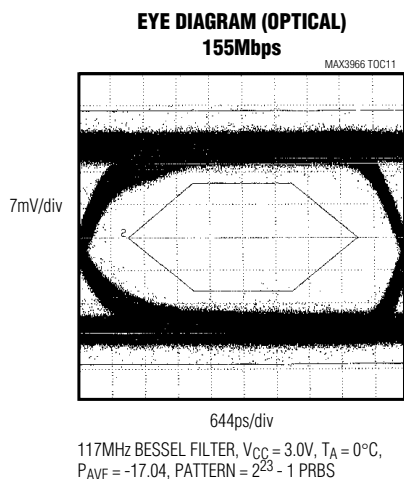
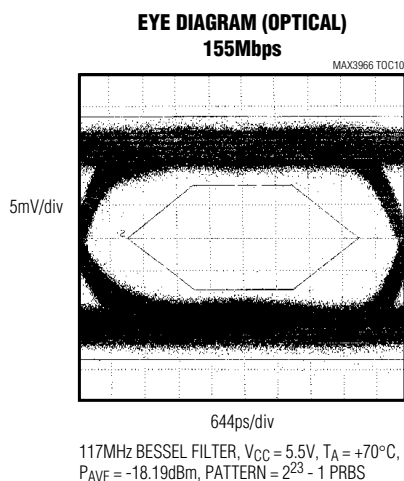

Pin Description

PIN		NAME	FUNCTION
24-PIN	16-PIN		
1, 2, 24	—	M2, M3, M1	Pins M1, M2, and M3 provide fine adjustment of the modulation current (Table 2).
3	2	MOD	A resistor from MOD to V_{EE} programs the LED modulation current.
4, 23	1	V_{CC}	Provides current to the internal amplifiers.
5	3	V_{BB}	Input Reference Voltage PECL Threshold Voltage Output. Connect V_{BB} to IN- for single-ended input.
6	4	IN-	Inverting Data Input
7	5	IN+	Noninverting Data Input
8	6	V_{EE}	Ground for Internal Amplifiers
9	7	TCMIN	Shorting TC to TCMIN provides the minimum modulation-current tempco.
10	—	TCNOM	Shorting TC to TCNOM provides a modulation tempco of approximately 3600ppm/ $^\circ C$.
11	8	TC	A resistor connected between the TC and TCMIN pins sets the tempco of the modulation current. Leaving TC unconnected provides the maximum tempco.
12, 13, 14	—	PB1, PB2, PB3	Programs the voltage prebias at the OUT+ pin (Table 1).
15, 16	9, 10	V_{EEOUT}	Ground for the Output Current Drivers
17, 18	11, 12	OUT+	Current-Output Pins
19, 20	13, 14	OUT-	Complementary Current-Output Pins
21, 22	15, 16	V_{CCOUT}	Supply Connection for the Output Current Drivers

LED Driver with Programmable Prebias Voltage

Detailed Description

The MAX3966 provides a flexible current drive for the modulation of fiber optic light-emitting diodes (LEDs). The circuit is designed to be used with +3.3V or +5V power supplies. The IC provides up to 100mA of modulation current. An adjustable prebias current source sets the LED prebias voltage. An integrated resistor provides passive peaking and optical pulse-width compensation.

Figure 2 shows a block diagram of the MAX3966, which comprises a reference-voltage generator, modulation-current generator, input buffer, prebias current generator, main output driver, complementary output driver, and LED-compensation network.

Reference-Voltage Generator and Temperature Compensation

The reference-voltage generator circuit provides the supply-referenced V_{BB} reference voltage and a reference voltage for the modulation-current generator.

A PECL-compatible V_{BB} generator is provided to simplify operation with a single-ended data input. For single-ended operation, connect the input signal to $IN+$, and connect V_{BB} directly to $IN-$. The V_{BB} circuit is not designed to drive other external circuitry. The V_{BB} output is implemented with an NPN emitter follower.

The reference-voltage generator circuit provides two voltage sources that create modulation-current temperature compensation. A positive modulation-current

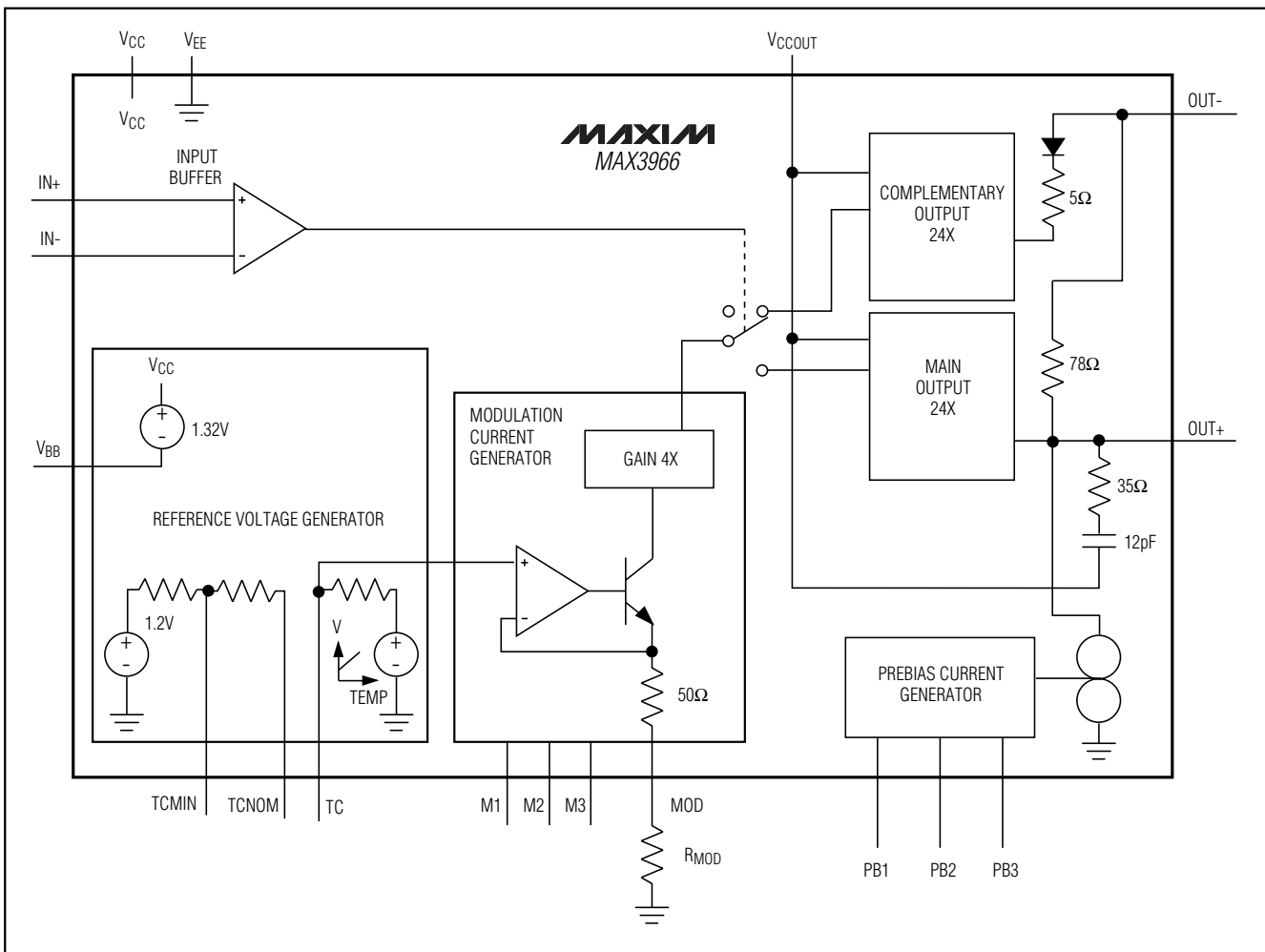

Figure 2. Functional Diagram

LED Driver with Programmable Prebias Voltage

temperature coefficient (tempco) is useful to compensate for the temperature characteristics of typical fiber optic LEDs. The first source has a temperature-stable output. The second source has a temperature-increasing output with a tempco of approximately 12,000ppm/°C (relative to +25°C). A resistor divider between the two reference generators programs the modulation-current tempco. For maximum modulation-current tempco, leave the TC pin disconnected. For a tempco of approximately 3600ppm/°C, connect TC to TCNOM. To obtain the minimum tempco, connect TCMIN to TC. Intermediate tempco values can be programmed by connecting an external resistor (R_{TC}) between TCMIN and TC.

Input Buffer

The inputs are connected to the PECL-compatible differential input buffer. If left unconnected, IN+ is internally pulled to a PECL low and IN- is pulled to a PECL high, causing low light output. The input impedance of IN+ and IN- is approximately 50kΩ.

Modulation-Current Generator

The modulation-current generator circuit provides control of the modulation-current amplitude. This amplitude is determined by the voltage at the MOD pin and external resistor R_{MOD}. Pins M1, M2, and M3 can be selectively connected to the positive supply to provide fine adjustment of the modulation current. Table 2 describes the functions of the M1, M2, and M3 pins.

Do not connect bypass capacitors at the MOD pin. Capacitance at this pin increases high-frequency output noise.

Prebias Current Generator

A prebias voltage (V_{PREBIAS}) can be applied to the LED to improve switching speed. The prebias current generator creates a current that flows through the 78Ω prebias resistor in the output stage, creating a prebias

voltage. The prebias voltage can be adjusted by selectively connecting pins PB1, PB2, and PB3 to V_{EE}. Table 1 describes the functions of PB1, PB2, and PB3.

Output Current Drivers

The modulation-current reference is switched and amplified by the output stages, which are implemented with NPN current mirrors.

LED package lead inductance causes ringing and overshoot, which can be compensated with an RC filter network. The MAX3966 includes 35Ω and 12pF of internal compensation. The compensation network can be optimized by adding additional components between V_{CCOUT} and OUT+.

The MAX3966 includes a complementary output driver, which is switched 180° out of phase with the main output. This configuration helps to maintain constant current flow from the voltage supply, reducing noise and EMI. A large diode and a 5Ω resistor are connected in series with the negative output (OUT-) to emulate the LED load at OUT+.

Peaking Current

The prebias resistor provides peaking current to improve the LED switching speed. The peaking magnitude is given by the following equation:

$$\text{PEAKING}_{\text{CURRENT}} \cong \frac{V_{\text{LED}} - V_{\text{PREBIAS}}}{78\Omega}$$

The peaking amplitude is equal for rising and falling data transitions.

Design Procedure

Select an LED

For best performance, select a high-efficiency, low-inductance LED. LED inductance causes large voltage swings and ringing.

Table 1. LED Prebias Voltage

PB1	PB2	PB3	PREBIAS (V)
Open	Open	Open	0.400
V _{EE}	Open	Open	0.475
Open	V _{EE}	Open	0.550
V _{EE}	V _{EE}	Open	0.625
Open	Open	V _{EE}	0.700
V _{EE}	Open	V _{EE}	0.775
Open	V _{EE}	V _{EE}	0.850
V _{EE}	V _{EE}	V _{EE}	0.925

Table 2. Modulation-Current Adjustment

M1	M2	M3	ADJUSTMENT (%)
Open	Open	Open	-4.0
Open	Open	V _{CC}	-3.0
Open	V _{CC}	Open	-2.0
Open	V _{CC}	V _{CC}	-1.0
V _{CC}	Open	Open	0
V _{CC}	Open	V _{CC}	1.0
V _{CC}	V _{CC}	Open	2.0
V _{CC}	V _{CC}	V _{CC}	3.0

LED Driver with Programmable Prebias Voltage

Program the Modulation-Current Tempco

Select a modulation-current tempco that provides nearly constant LED output power as temperature varies. For the minimum tempco, connect TCMIN to the TC pin. For a tempco of approximately 3600ppm/°C, connect TC to TCNOM and leave TCMIN unconnected. For the maximum tempco, leave TCMIN, TCNOM, and TC unconnected.

Refer to the Modulation-Current Temperature Coefficient vs. RTC Resistor graph in the *Typical Operating Characteristics* to program a custom tempco. From the graph, determine the appropriate resistor and connect it between TCMIN and TC.

For example, if an LED requires a 5000 ppm/°C tempco, choose RTC of 10Ω.

Program the Modulation Current

Determine the required modulation current at $T_A = +25^\circ\text{C}$. Then select the appropriate value of R_{MOD} from the Modulation Current vs. R_{MOD} graph in the *Typical Operating Characteristics*, which provides the required current.

For example, to program 80mA modulation current, the graph indicates an R_{MOD} value of 750Ω for maximum tempco (12,000ppm/°C) and 1.1kΩ for nominal tempco (3600ppm/°C). By interpolation, choose an R_{MOD} of 1.05kΩ for a tempco of 5000ppm/°C.

Program Prebias Voltage

Determine the LED prebias voltage that produces an acceptable trade-off between peaking current and extinction ratio. Refer to Table 1 for PB1, PB2, and PB3 settings.

Layout Considerations

For optimum performance, total load inductance should not exceed 10nH. Load inductance includes LED inductance, LED package lead inductance, and circuit-board traces. Keep the connections between the MAX3966 OUT pins and the LED as short as possible to minimize inductance.

Chip-and-wire (hybrid) technology reduces package inductance significantly, and provides the best possible performance.

Use good high-frequency layout techniques. Use a multilayer board with an uninterrupted ground plane. Power supplies should be capacitively bypassed to the ground plane with surface-mount capacitors located near the power-supply pins.

Applications Information

Input Terminations

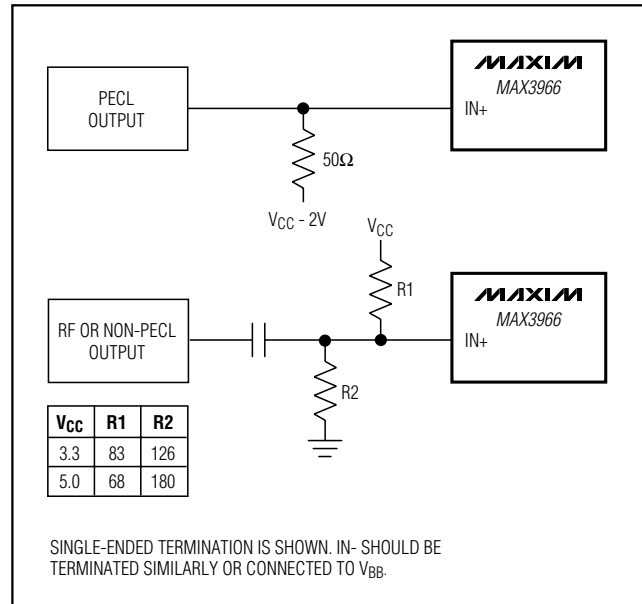

Figure 3. Input Terminations

Wire-Bonding Die

The MAX3966 utilizes gold metalization, which provides high reliability. Make connections to the die with gold wire only, using ball-bonding techniques. Wedge bonding is not recommended. Pad size is 4mil square (100μm). Die thickness is typically 15mil (375μm).

LED Driver with Programmable Prebias Voltage

Pin Configurations

MAX3966

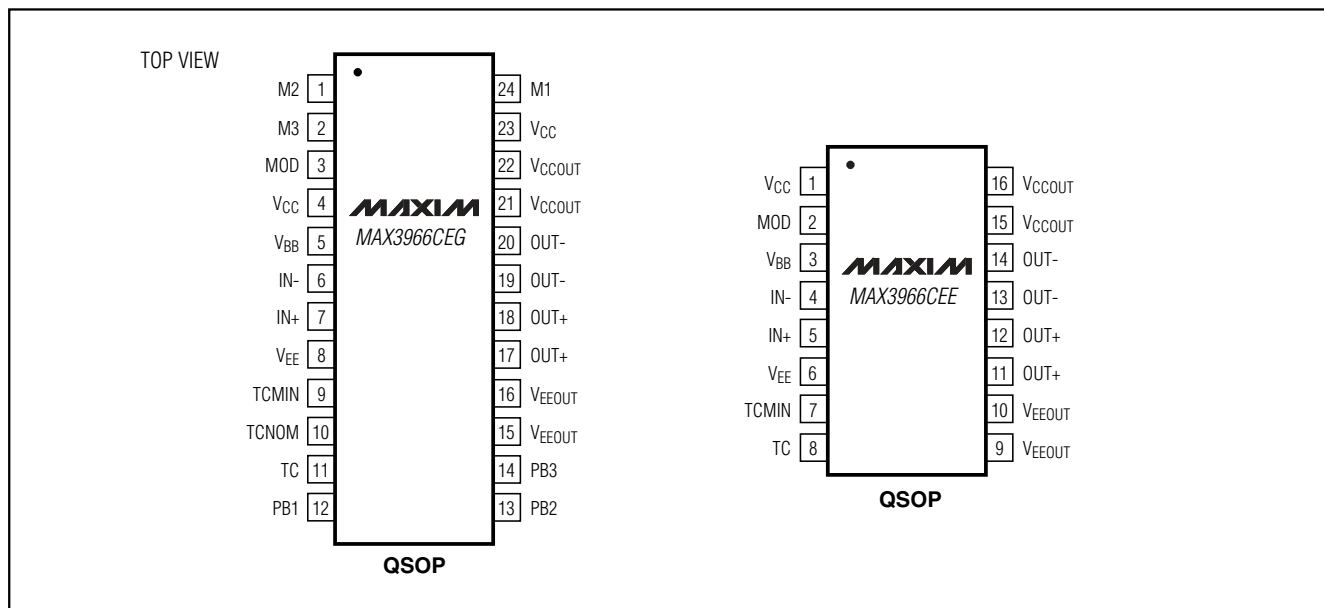

LED Driver with Programmable Prebias Voltage

Chip Topography

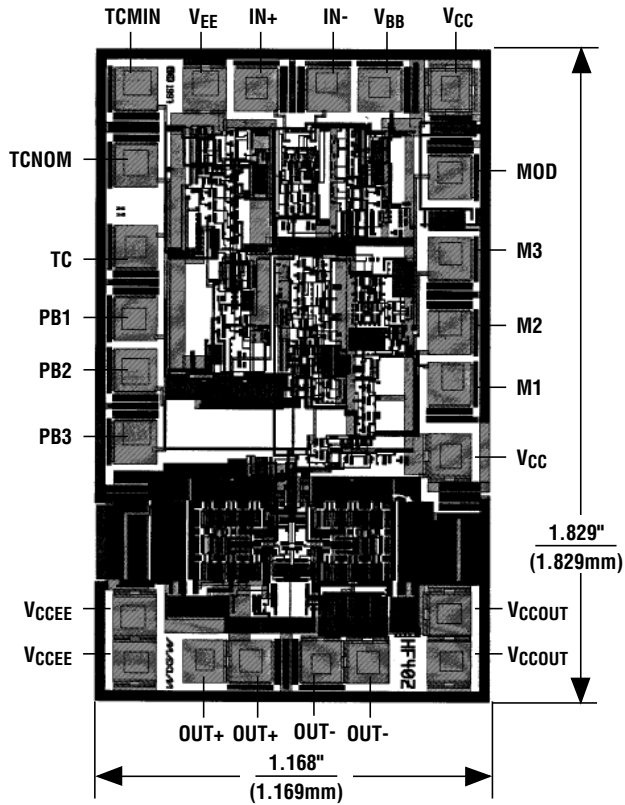

TRANSISTOR COUNT: 304
 SUBSTRATE CONNECTED TO VEE

LED Driver with Programmable Prebias Voltage

Package Information

MAX3966

DIM	INCHES		MILLIMETERS	
	MIN	MAX	MIN	MAX
A	.061	.068	1.55	1.73
A1	.004	.0098	0.102	0.249
A2	.055	.061	1.40	1.55
B	.008	.012	0.20	0.31
C	.0075	.0098	0.191	0.249
D	SEE VARIATIONS			
E	.150	.157	3.81	3.99
e	.025 BSC		0.635 BSC	
H	.230	.244	5.84	6.20
h	.010	.016	0.25	0.41
L	.016	.035	0.41	0.89
N	SEE VARIATIONS			
X	SEE VARIATIONS			
Y	.071	.087	1.803	2.209
alpha	0°	8°	0°	8°

DIM	INCHES		MILLIMETERS		N
	MIN	MAX	MIN	MAX	
D	.189	.196	4.80	4.98	16 AA
S	.0020	.0070	0.05	0.18	
X	.107	.123	2.72	3.12	
D	.337	.344	8.56	8.74	20 AB
S	.0500	.0550	1.270	1.397	
D	.337	.344	8.56	8.74	24 AC
S	.0250	.0300	0.635	0.762	
D	.386	.393	9.80	9.98	28 AD
S	.0250	.0300	0.635	0.762	
X	.271	.287	6.88	7.29	

NOTES:

1. D & E DO NOT INCLUDE MOLD FLASH OR PROTRUSIONS
2. MOLD FLASH OR PROTRUSIONS NOT TO EXCEED .006" PER SIDE.
3. HEAT SLUG DIMENSIONS X AND Y APPLY ONLY TO 16 AND 28 LEAD POWER-QSOP PACKAGES.
4. CONTROLLING DIMENSIONS: INCHES.

MAXIM

PROPRIETARY INFORMATION

TITLE:

PACKAGE OUTLINE, QSOP, .150", .025" LEAD PITCH

APPROVAL	DOCUMENT CONTROL NO.	REV
	21-0055	B 1/1

LED Driver with Programmable Prebias Voltage

NOTES