

LOC	DIST	REV	DATE	BY	CHK	APPV
AA	22	K1	18MAY2011	RK	HMR	
		L	27APR2015	LL	SH	

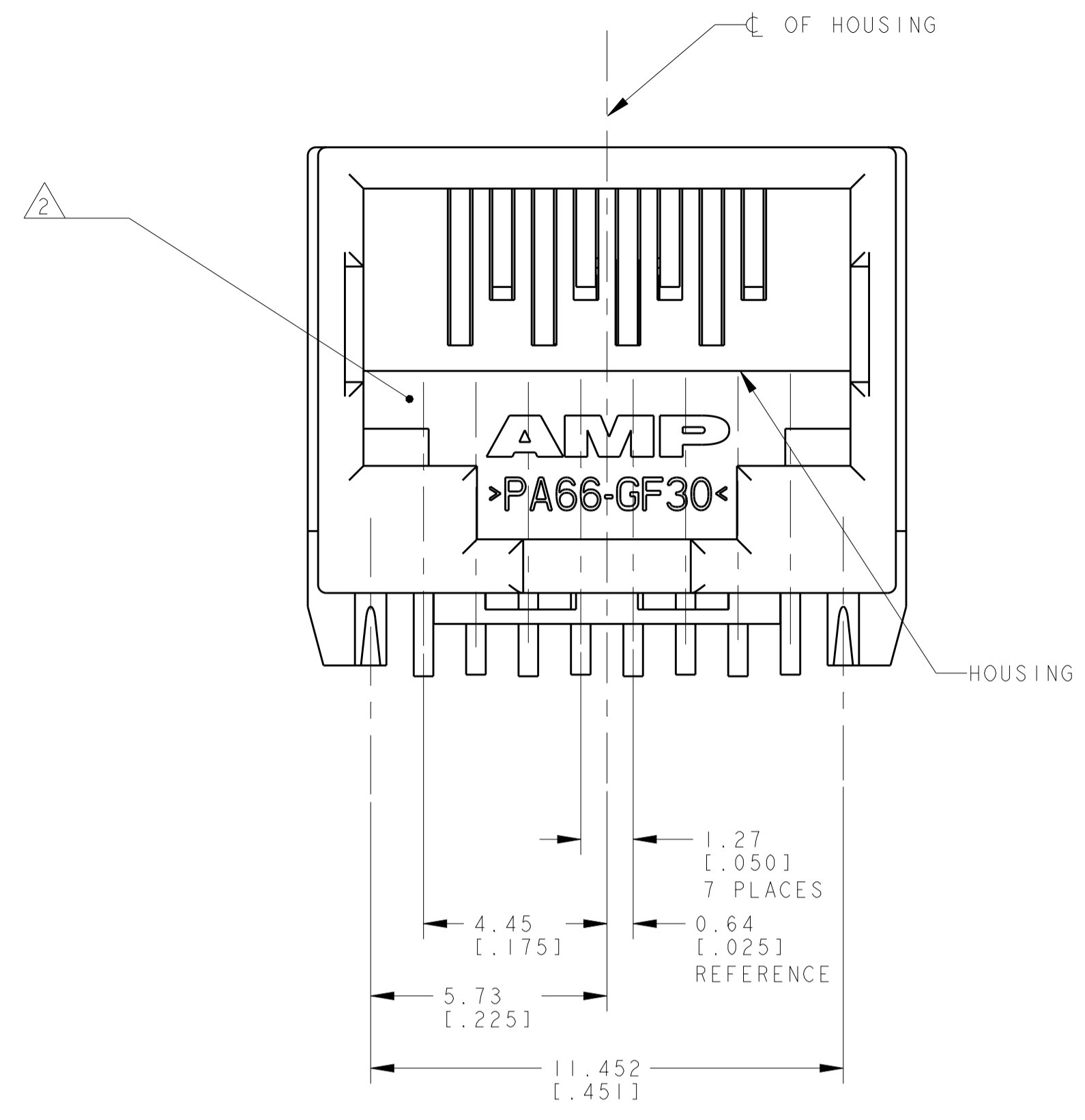

- 1. MATERIAL: HOUSING - HIGH TEMPERATURE NYLON, BLACK, UL 94V-0, IR REFLOW SOLDERING PROCESS COMPATIBLE  
TERMINALS - 0.25 [0.010] THICK PHOSPHOR BRONZE PLATED WITH 3.81µm [0.000150] MINIMUM THICK BRIGHT TIN-LEAD IN SOLDER AREA, 1.27µm [0.000050] MINIMUM GOLD IN LOCALIZED PLATE AREA. ENTIRE TERMINAL PLATED WITH 1.27µm [0.000050] MINIMUM THICK NICKEL.
- 2. JACK CAVITY CONFORMS TO FCC RULES AND REGULATIONS PART 68, SUBPART F.
- 3. THIS DIMENSION REPRESENTS THE TOTAL HEIGHT OF THE CONNECTOR FROM THE TOP OF THE PC BOARD.
- 4. PACKAGED 66 ASSEMBLIES PER PVC TRAY, 396 PER BOX.
- 5. MANUFACTURING DATE CODE:  
ORIENTED AND LOCATED APPROXIMATELY AS SHOWN. LASER PRINTING.  
TEXT HEIGHT APPROXIMATELY 2MM.  
FIRST 2 DIGITS = LAST 2 DIGITS OF YEAR  
NEXT 2 DIGITS = MANUFACTURING WORK WEEK  
LAST DIGIT = DAY OF WEEK WITH SUNDAY = 1
- 6. MATERIAL: HOUSING - HIGH TEMPERATURE NYLON, BLACK, UL 94V-0, IR REFLOW SOLDERING PROCESS COMPATIBLE  
TERMINALS - 0.25 [0.010] THICK PHOSPHOR BRONZE PLATED WITH 3.81µm [0.000150] MINIMUM THICK MATTE TIN IN SOLDER AREA, 1.27µm [0.000050] MINIMUM GOLD IN LOCALIZED PLATE AREA. ENTIRE TERMINAL PLATED WITH 1.27µm [0.000050] MINIMUM THICK NICKEL.

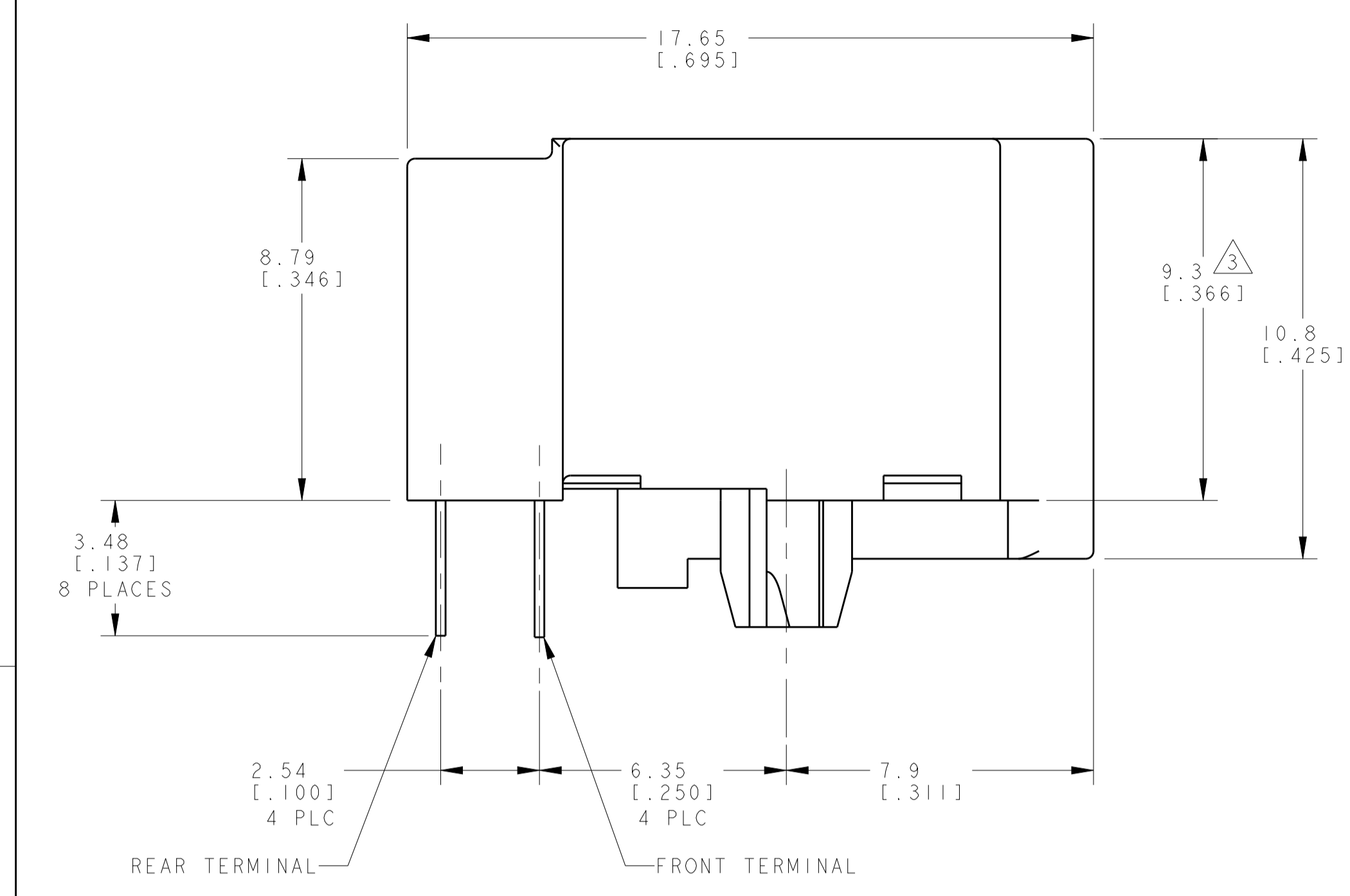
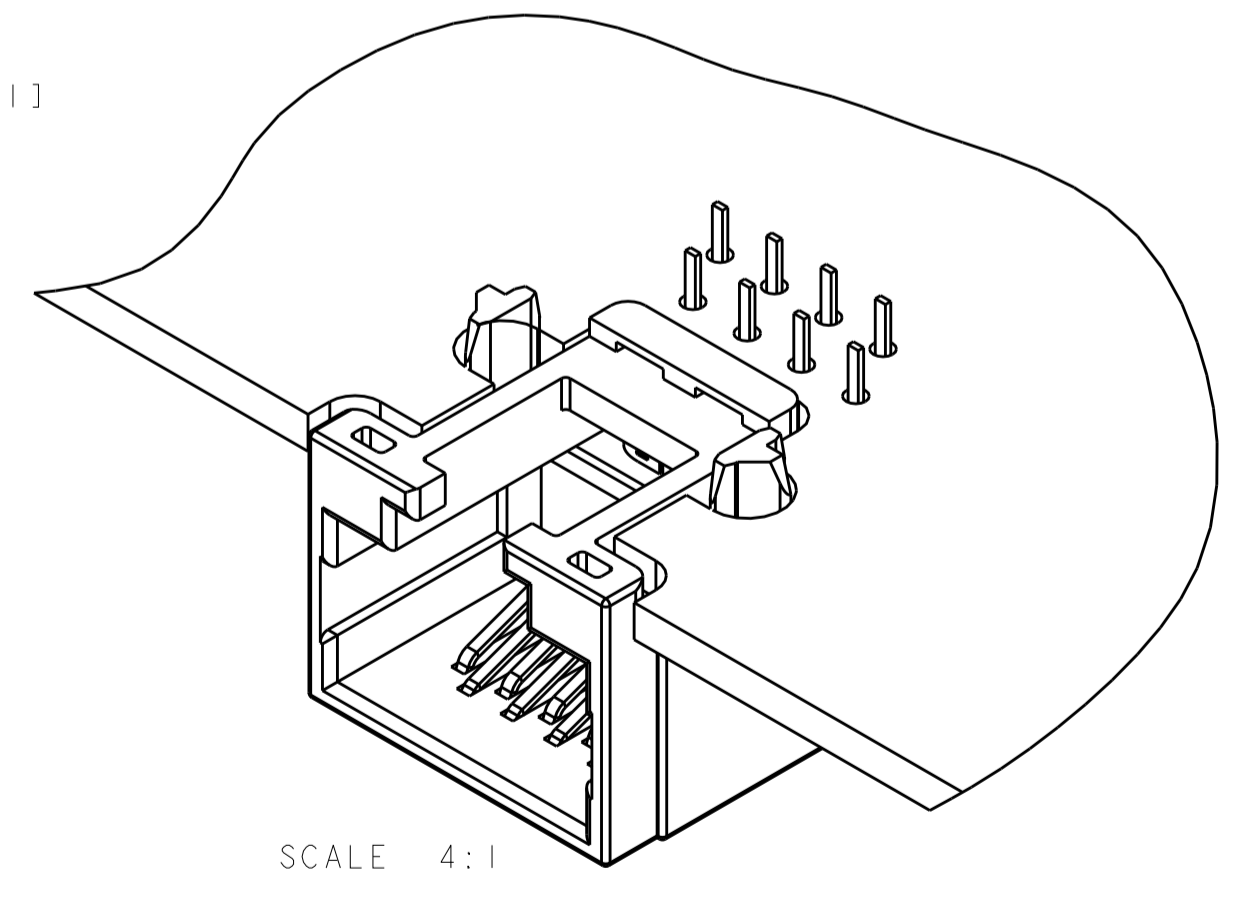
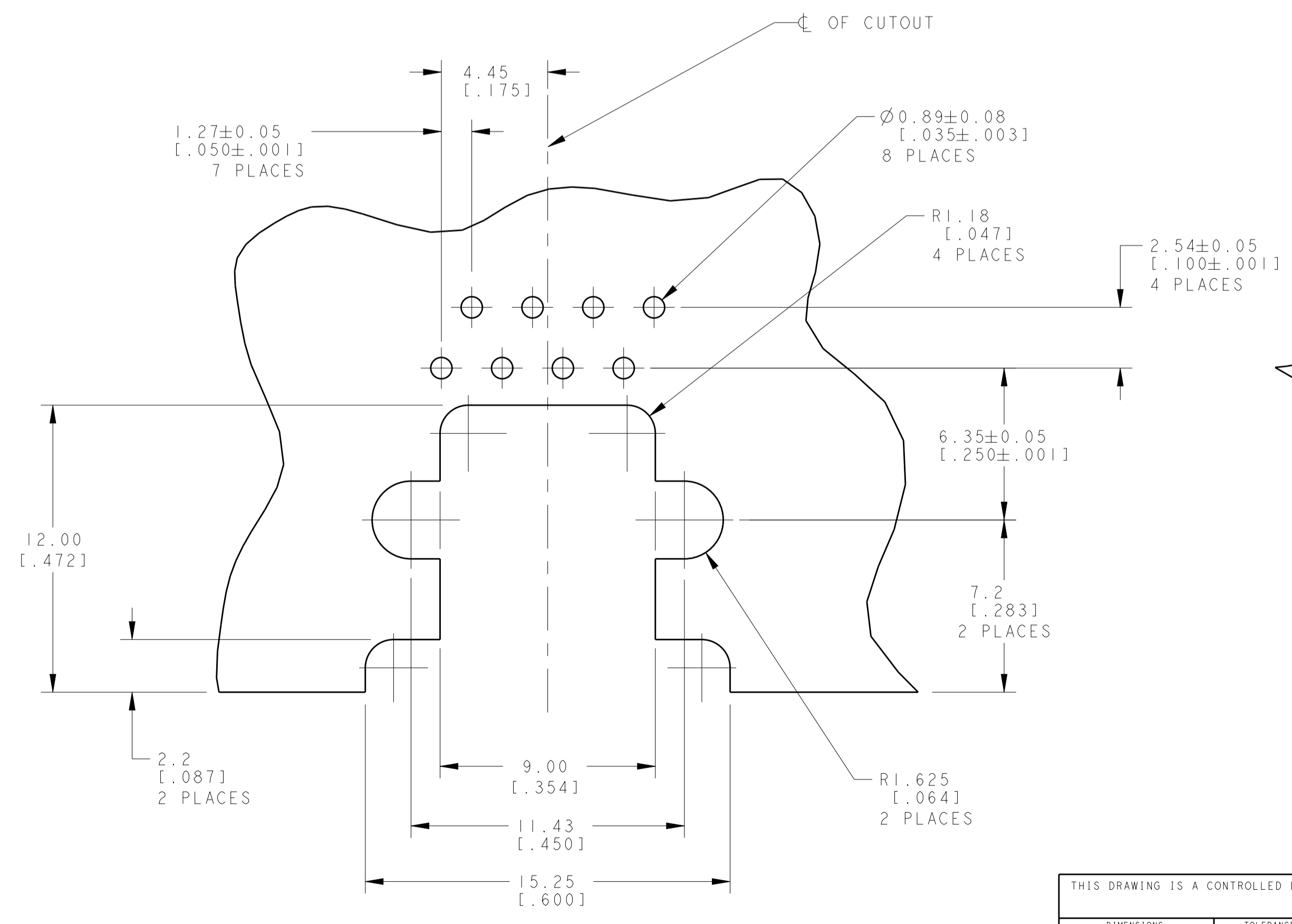
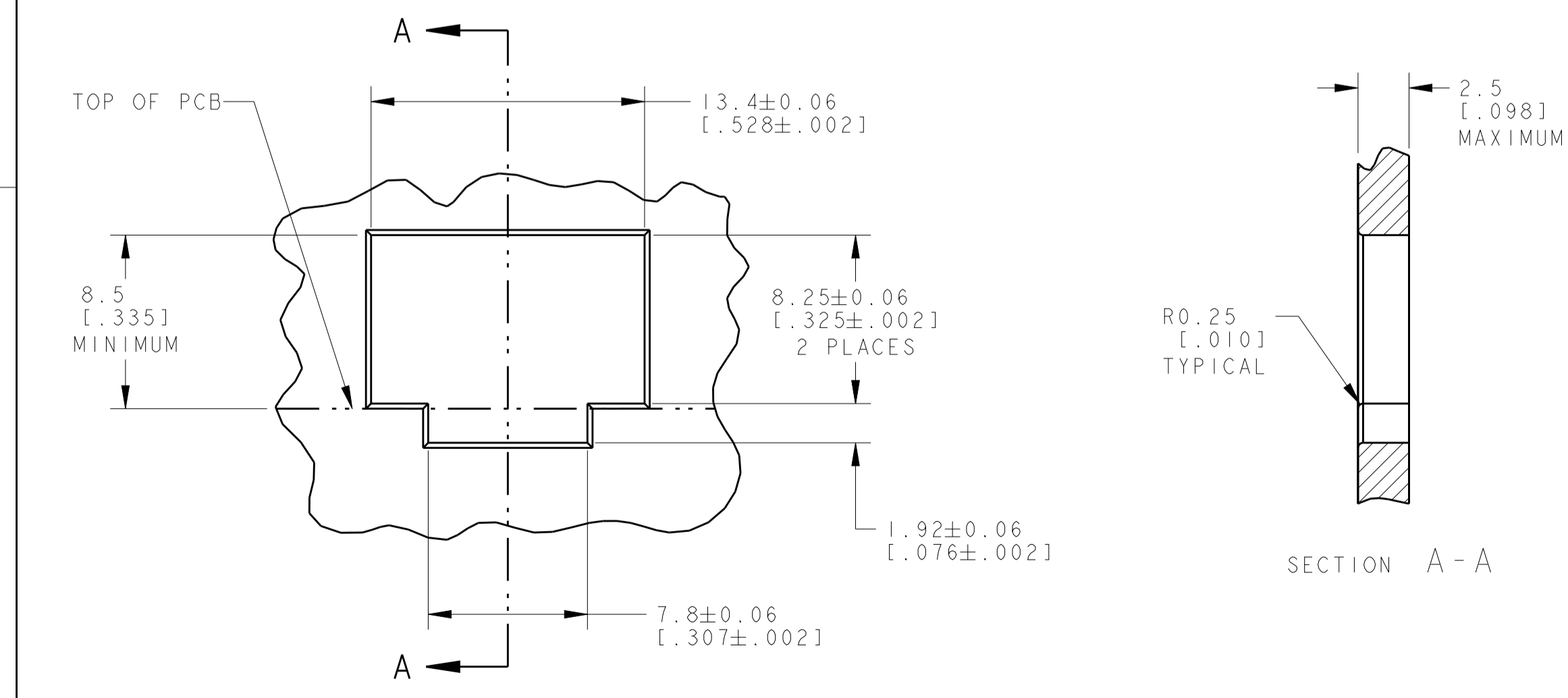
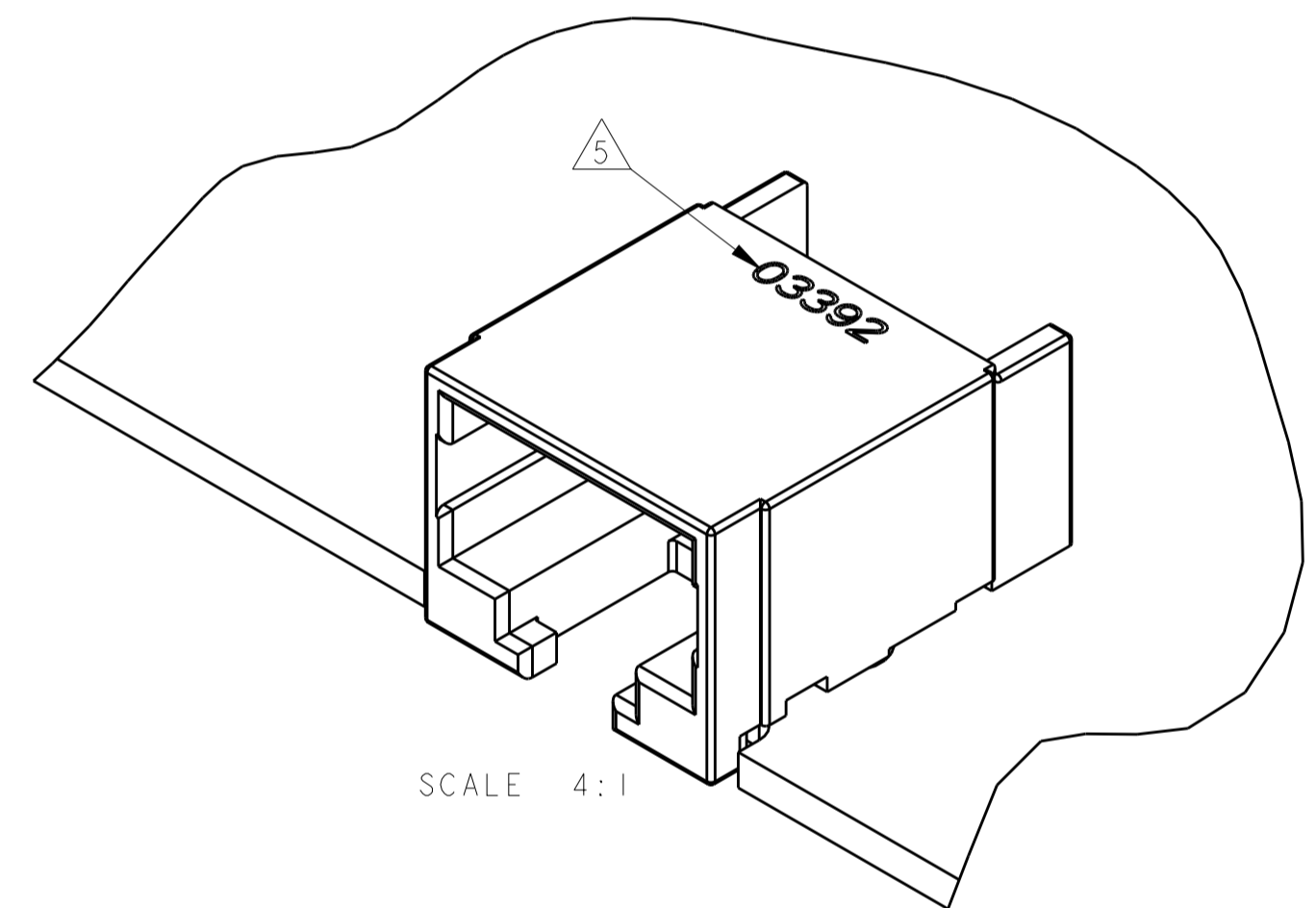
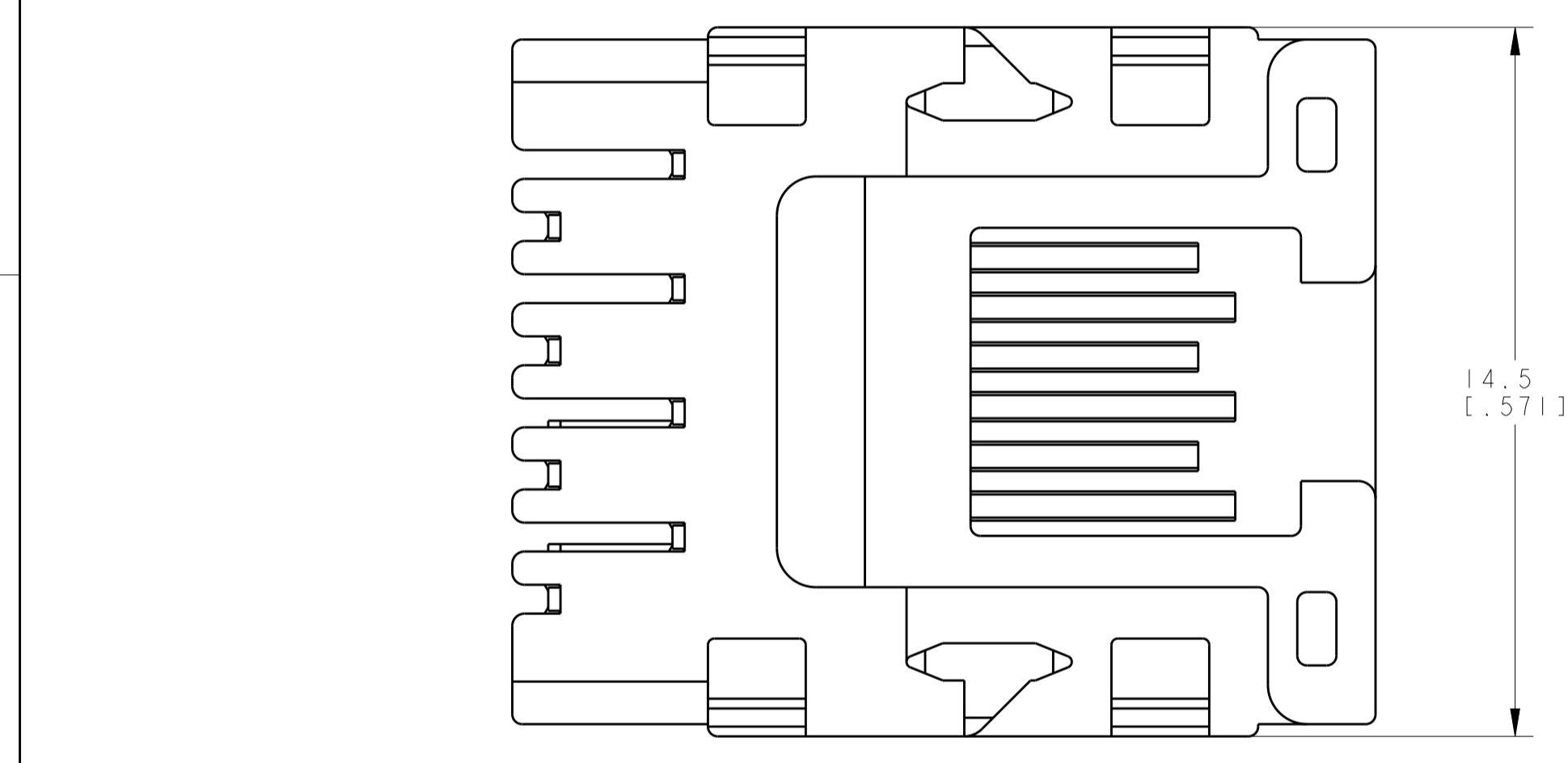

6	1116504-2
1	1116504-1
MATERIAL/ FINISH	PART NUMBER

SUGGESTED PANEL CUTOUT SCALE 4:1

SUGGESTED PRINTED CIRCUIT BOARD LAYOUT COMPONENT SIDE SCALE 6:1

THIS DRAWING IS A CONTROLLED DOCUMENT.		OWN T. SPRINKLE 28JAN99	1116504-2	
DIMENSIONS: mm [INCHES]		CHK D. KEMPKA 28JAN99	1116504-1	
TOLERANCES UNLESS OTHERWISE SPECIFIED:		APVD D. KEMPKA 28JAN99	MATERIAL/ FINISH PART NUMBER	
0 PLC ±	1 PLC ±	PRODUCT SPEC	TE Connectivity	
2 PLC ±0.131(.005)	3 PLC ±	108-1163	MODULAR JACK ASSEMBLY, 8 POSITION, 10mm	
4 PLC ±	ANGLES ±	APPLICATION SPEC	-	
MATERIAL SEE P/N TABLE		114-2048	SIZE CAGE CODE DRAWING NO	RESTRICTED TO
FINISH SEE P/N TABLE		WEIGHT 3.49 grams	A100779	1116504
		CUSTOMER DRAWING	SCALE 8:1	SHEET 1 OF 1 REV L