

ORDER NO.	WOODHEAD NO.	COLOR
130147-0245	27W09MB-P	YELLOW

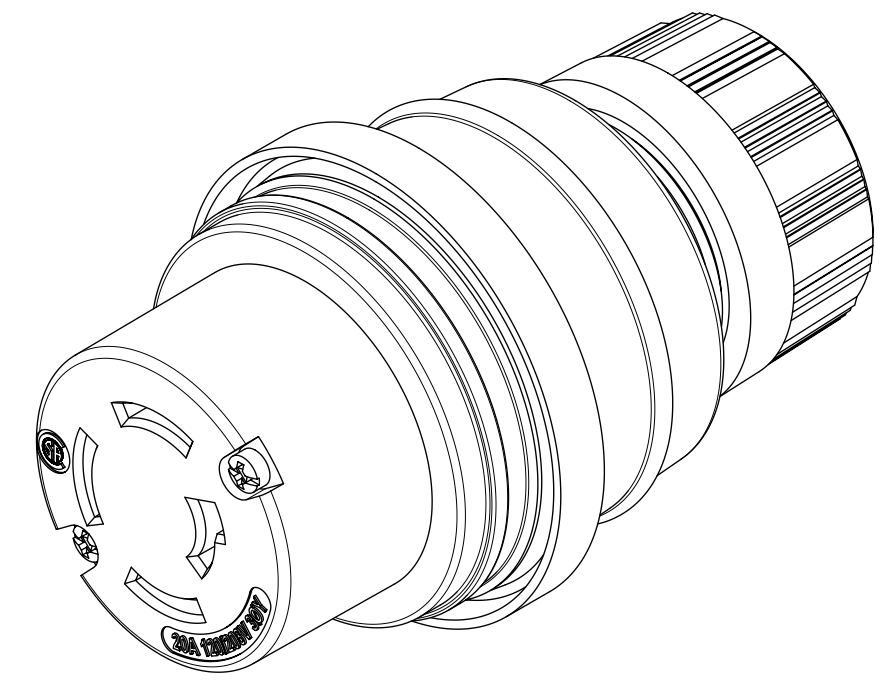
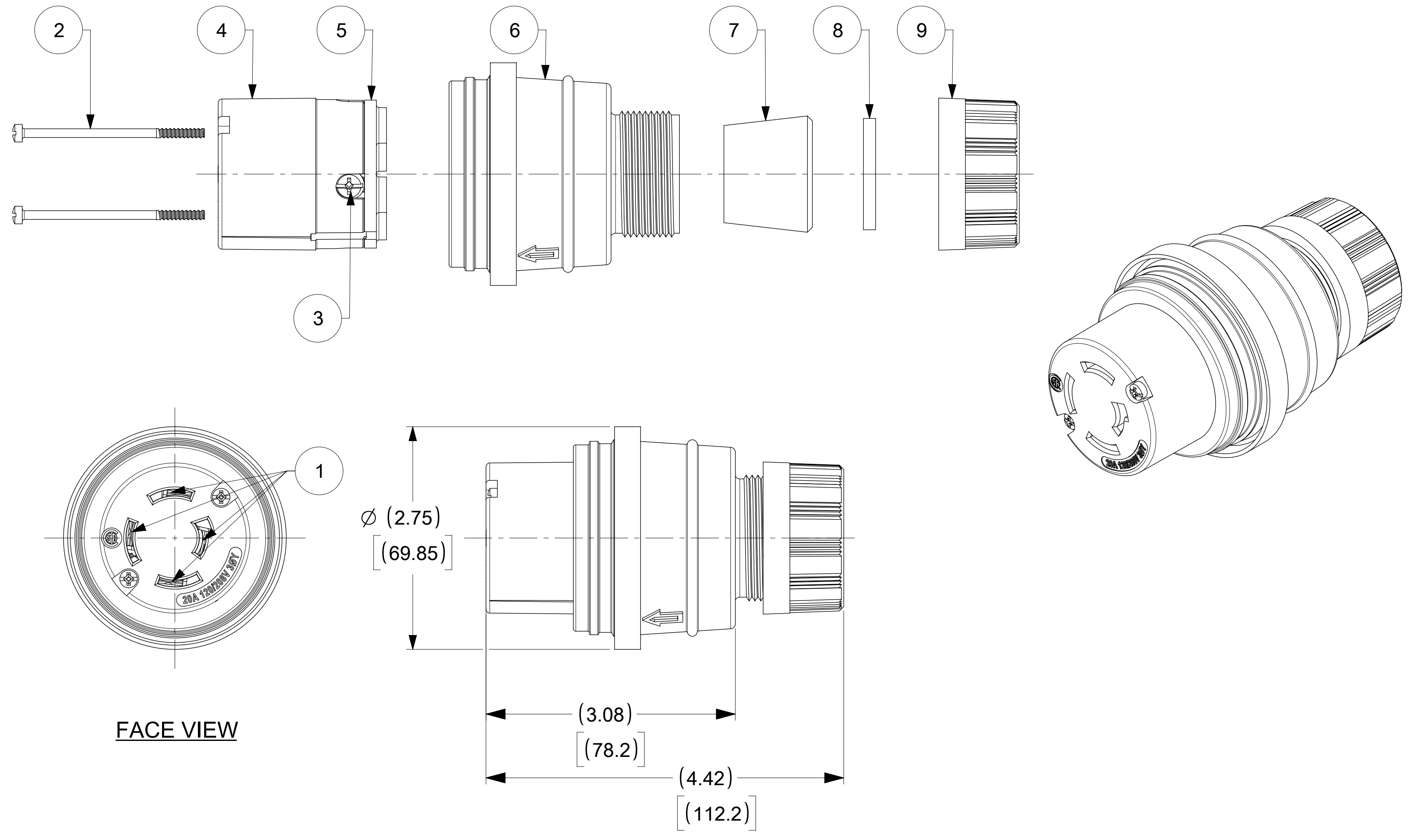

ITEM NO.	DESCRIPTIONS	MATERIAL	QTY.
1	BLADE	BRASS, NICKEL PLATED	4
2	RETAINING SCREWS	STAINLESS STEEL	2
3	CLAMP AND TERMINAL SCREW ASSY	BRASS, ZINC PLATED	4
4	INSERT	NYLON	1
5	TERMINAL COVER	POLYCARBONATE	1
6	HOUSING	SILICON WITH NYLON THREAD	1
7	GROMMET	RUBBER	1
8	FRICTION RING	NYLON	1
9	COMPRESSION NUT	NYLON	1

SYMBOLS DIMENSION UNITS: INCH[MM] SCALE: NTS GENERAL TOLERANCES (UNLESS SPECIFIED): 4 PLACES ± 3 PLACES ± 2 PLACES ± 1 PLACE ± 0 PLACES ± ANGULAR TOL ± ° DRAFT WHERE APPLICABLE MUST REMAIN WITHIN DIMENSIONS		THIS DRAWING CONTAINS INFORMATION THAT IS PROPRIETARY TO MOLEX ELECTRONIC TECHNOLOGIES, LLC AND SHOULD NOT BE USED WITHOUT WRITTEN PERMISSION CURRENT REV DESC: RELEASED EC NO: 614215 DRWN: DSOPPIN 2019/01/08 CHK'D: DNGUYEN62 2019/03/29 APPR: HKNEELAND 2019/03/30 INITIAL REVISION: DRWN: DSOPPIN 2019/01/08 APPR: HKNEELAND 2019/03/30		 WATERTITE CONNECTOR MOTOR BASE 4P4W NON-NEMA PRODUCT CUSTOMER DRAWING	
DOCUMENT STATUS: P1 RELEASE DATE: 2019/03/30 23:01:31		DOCUMENT NUMBER: 1301470245 DOC TYPE: PSD DOC PART: 000 REVISION: A		MATERIAL NUMBER: SEE TABLE CUSTOMER: GENERAL MARKET SHEET NUMBER: 1 OF 1	