

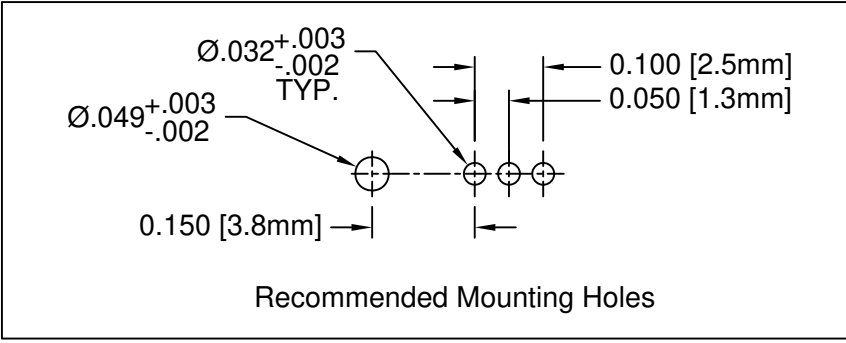

REV.	DESCRIPTION	DATE	APPROVED
A	Engineering Update w/o Changes	02/27/04	M. C.
B	Typo Correction	04/04/06	M. C.
C	Removed Part Number from Part Offering List	05/06/15	J. C.
D	Removed Material Code	05/28/16	J. C.

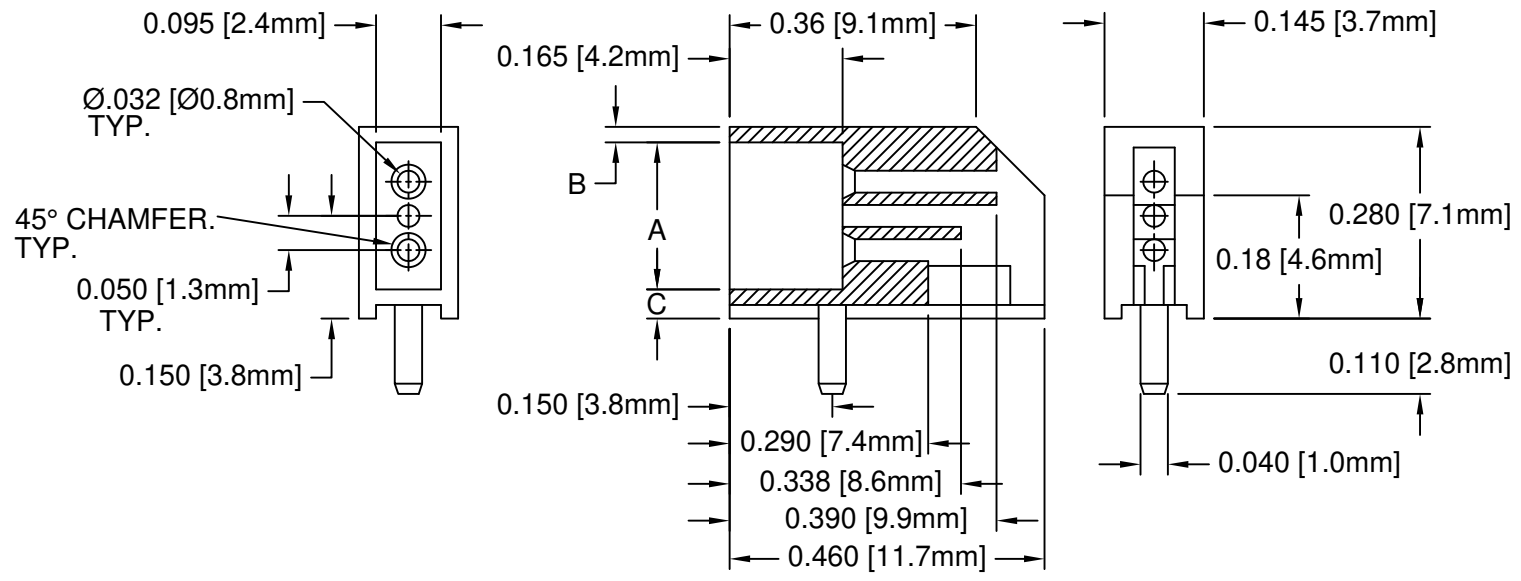

PART NO.	A	B	C
H-2RV-5	.215 (5.5mm)	.022(.6mm)	.043 (1.1mm)

STANDARD TOLERANCE (UNLESS OTHERWISE SPECIFIED)		 BIVAR [®] 4 THOMAS, IRVINE, CA. 92618 TEL: (949) 951-8808 FAX: (949) 951-3974	
DECIMALS	ANGULAR		
.X ± .1	X° ± 1°	 TITLE: MULTIPLE SIZE RECTANGULAR LED HOLDER BI-LEAD / TRI-LEAD	
.XX ± .01			
.XXX ± .005			
DESIGNED: S. Irving	DATE: 10/22/99	PART NO: H-2RV-X	REVISION: D
CHECKED: D. Green	DATE: 02/27/04	CAGE CODE : 32559	SHEET # 1 OF 1
CAD GENERATED DOCUMENT. DO NOT MEASURE DRAWING.			

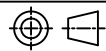
- 2. MATERIAL: NYLON 6/6, 94V-0, BLACK.
- 1. GENERAL SPECIFICATIONS: BIVAR MOLDED COMPONENT SPECIFICATION BV00-E101.