







# VDSL/VDSL2 Transformer

EP Platform SMD



-  VDSL/VDSL2 Transformer
-  Compatible with Broadcom BCM6511/26 Class A/B Line Driver
-  EN60950 Functional Isolation Compliant - 250Vrms
-  Designed to meet ITU K.20 enhanced level testing requirements
-  RoHS-6 Compliant SMD Product
-  Available on Tape and Reel

## Electrical Specifications @ 25°C - Operating Temperature @ -40°C to +85°C

Part Number	OCL Line (1-4) with (2-3) shorted 10kHz, 100mVrms (uH±10%)	Turns Ratio (1-4): (8-5) with (2-3, 6-7) shorted 100kHz, 100mVrms ±2%	Leakage Inductance (1-4) with others shorted 100kHz, 100mVrms (uH, Max)	Cww Line to Chip 100kHz, 100mVrms (pF Max)	THD @ 30kHz 3.0Vrms (dB Min)	
BX4246LNL	430	1.11:1	0.8	40	-62.0	
* BX4246LNLT	DCR (1-4) with (2-3) shorted (OHMS Max)	DCR (8-5) with (6-7) shorted (OHMS Max)	LB 12MHz (dB Max)	LB 17MHz (dB Max)	LB 30MHz (dB, Max)	Isolation Voltage Pri:Sec (Vac, 60Sec)
	0.9	0.8	-44	-42	-30	1500

### Notes:

\* Use this part number to order product to be shipped on Tape & Reel

## Mechanical

**BX4246LNL, BX4246LNLT**

PIN 1 IDENTIFICATION

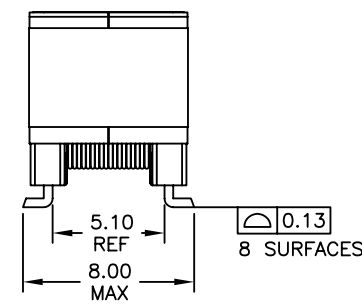
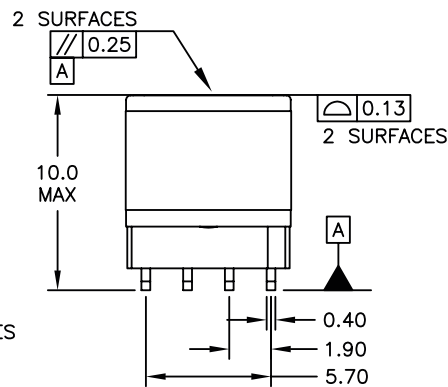
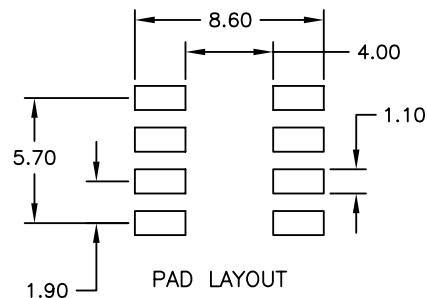
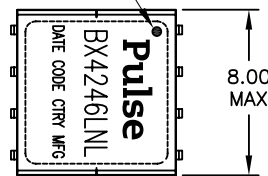

# VDSL/VDSL2 Transformer

EP Platform SMD

## Schematic

BX4246LNL, BX4246LNL1

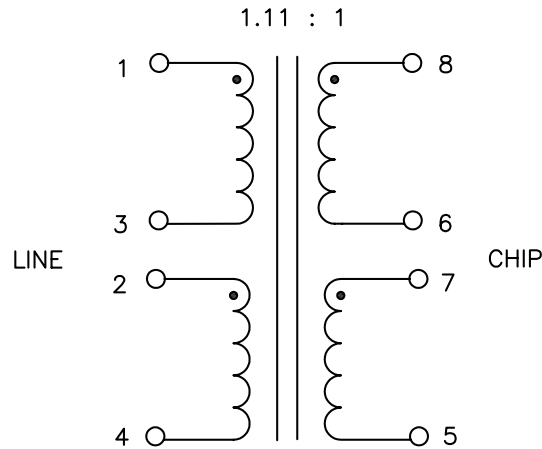

Weight .....1.5 grams

Tape & Reel .....300/reel

Tray .....100/tray

Dimensions:  $\frac{\text{Inches}}{\text{mm}}$

Unless otherwise specified,  
all tolerances are  $\pm \frac{.010}{0,25}$

## For More Information

### Pulse Worldwide Headquarters

12220 World Trade Drive  
San Diego, CA  
92128  
U.S.A.

Tel: 858 674 8100  
Fax: 858 674 8262

### Pulse Europe

Einsteinstrasse 1  
D-71083 Herrenberg  
Germany

Tel: 49 7032 78060  
Fax: 49 7032 7806 135

### Pulse China Headquarters

B402, Shenzhen Academy of  
Aerospace Technology Bldg.  
10th Kejinan Road  
High-Tech Zone  
Nanshan District  
Shenzen, PR China  
518057  
Tel: 86 755 33966678  
Fax: 86 755 33966700

### Pulse North China

Room 2704/2705  
Super Ocean Finance  
Ctr.  
2067 Yan An Road  
West  
Shanghai 200336  
China

Tel: 86 21 62787060  
Fax: 86 2162786973

### Pulse South Asia

135 Joo Seng Road  
#03-02  
PM Industrial Bldg.  
Singapore 368363

Tel: 65 6287 8998  
Fax: 65 6287 8998

### Pulse North Asia

3F, No. 198  
Zhongyuan Road  
Zhongli City  
Taoyuan County 320  
Taiwan R. O. C.  
Tel: 886 3 4356768  
Fax: 886 3 4356823 (Pulse)  
Fax: 886 3 4356820 (FRE)

Performance warranty of products offered on this data sheet is limited to the parameters specified. Data is subject to change without notice. Other brand and product names mentioned herein may be trademarks or registered trademarks of their respective owners. © Copyright, 2014. Pulse Electronics, Inc. All rights reserved.