

Development Board for The EL-OEM-3

FEATURES

- USB interface for setup and download of data
- Bread boarding area provided
- Various power supply options



The EL-OEM-TEST is a board designed to assist in development of circuits using the EL-OEM-3 data logger.

The EL-OEM-TEST features a mini-USB connector, battery socket, 5 to 24V external power supply input and development options for input signal conditioning including positions for scaling resistors and an op-amp circuit. There is also a small bread-boarding area provided. With the interface designed and tested, the required circuitry can be transferred to a product specific PCB.

Power Supply:

To operate from an external power supply, PWR LINK must NOT be fitted.

To operate from the battery, make BAT LINK. Ensure that PWR LINK and 0V LINK are not made.

To operate from USB power, make links PWR LINK and 0V LINK. Do NOT fit any other external power source

Measurement Input:

The measurement range for the EL-OEM-3 is 0 to 2.4V d.c. which can be connected directly to INHI and INLO.

If you need to measure higher voltage, scaling resistors can be fitted to RA and RB with RA LINK being open. Further information on scaling can be found on the data sheet for the EL-OEM-3.

To buffer the input, you will need to fit components R4, R5, R6, C4 and IC3 configured as a non-inverting amplifier. Links PL11 and PL12 should be made while RA LINK is left open (RA must also not be fitted).

Alarm Output:

ALM1 and ALM2 will operate as per the Alarm Output Modes information on the data sheet for the EL-OEM-3. The EL-OEM-TEST board has LEDs fitted in line with the two outputs that will flash when alarm conditions are triggered. The maximum current output for the alarms is 10mA (including 3mA for the LED).

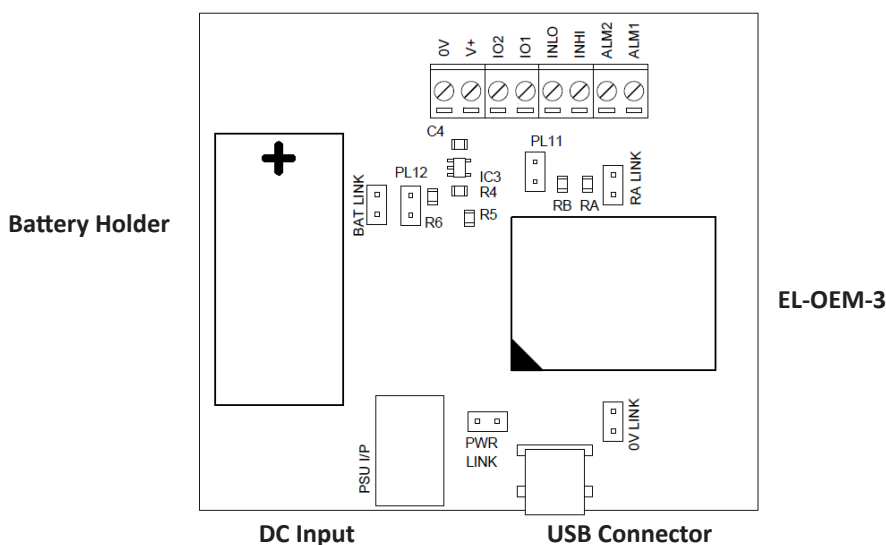

ACCESSORIES

BAT 3V6 1/2AA Replacement Battery

INCLUDED IN THE BOX

BAT 3V6 1/2AA Battery

CABLE USB A-MF USB Cable

EL-OEM-3 OEM Packaged Voltage Logger

EL-OEM-TEST

Development Board for The EL-OEM-3

