

DC Brushless Motor Drivers for Cooling Fans

# Two-Phase Half-Wave Pre Driver Fan Motor Driver



## BA6406F

• **General description**

BA6406F is two-phase half-wave fan motor pre-driver. This driver incorporates lock protection, automatic restart circuit and Lock alarm signal output.

• **Features**

- Incorporates lock protection
- Automatic restart circuit
- Lock alarm signal (AL) output

• **Package**

SOP8

W (Typ.) x D (Typ.) x H (Max.)

5.00mm x 6.20mm x 1.71mm

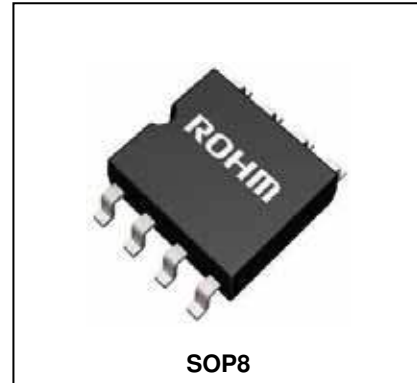

• **Application**

- For desktop PC, server, general consumer equipment, communication equipment and industrial equipment.

• **Absolute maximum ratings**

Parameter	Symbol	Limit	Unit
Supply voltage	Vcc	30	V
Power dissipation	Pd	624 <sup>*1</sup>	mW
Operating temperature	Topr	-40 to +100	°C
Storage temperature	Tstg	-55 to +125	°C
Output current	Iomax	70	mA
AL signal output current	IAL	8	mA
AL signal output voltage	VAL	30	V
Junction temperature	Tjmax	125	°C

\*1 Reduce by 6.24mW/°C over Ta=25°C. (On 70.0mm×70.0mm×1.6mm glass epoxy board)

• **Recommended operating conditions**

Parameter	Symbol	Limit	Unit
Operating supply voltage range	Vcc	4.0 to 28.0	V
Hall input voltage range	VH	1.0 to Vcc-0.5	V

• Pin configuration

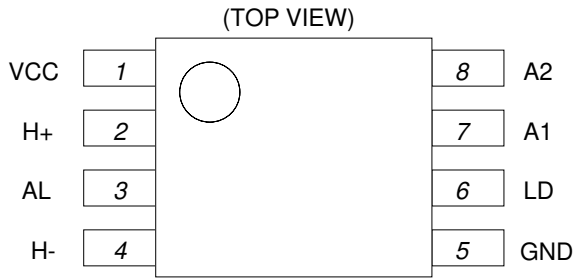

Fig.1 Pin configuration

• Pin description

P/No.	T/Name	Function
1	Vcc	Power terminal
2	H+	Hall input terminal +
3	AL	Lock alarm signal output terminal
4	H-	Hall input terminal -
5	GND	GND terminal
6	LD	Lock detection and automatic restart capacitor connecting terminal
7	A1	Output terminal 1
8	A2	Output terminal 2

• Block diagram

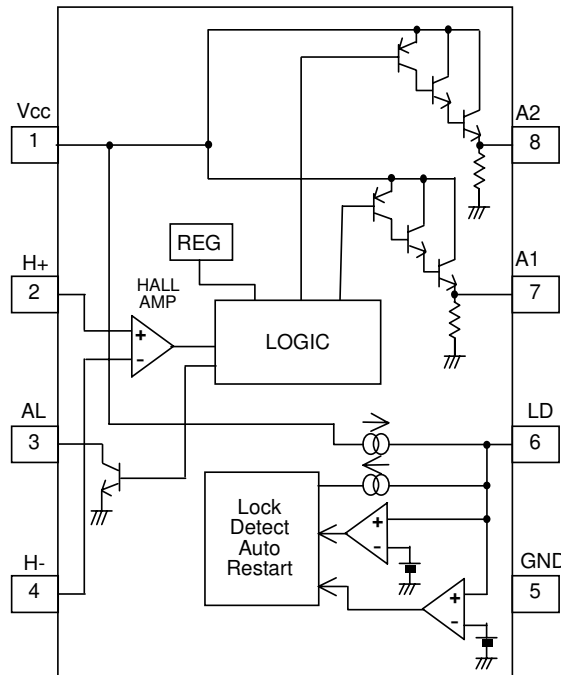

Fig.2 Block diagram

• I/O truth table

H+	H-	A1	A2
H	L	H(Output Tr ON)	L(Output Tr OFF)
L	H	L(Output Tr OFF)	H(Output Tr ON)

H; High, L; Low, Hi-Z; High impedance  
 FG output is open-drain type.

Motor state	AL
Rotating	L
Locking	Hi-Z

L; Low, Hi-Z; High impedance  
 AL output is open-drain type.

• Electrical characteristics(Unless otherwise specified Ta=25°C, Vcc=12V)

Parameter	Symbol	Limit			Unit	Conditions
		Min.	Typ.	Max.		
Circuit current	I <sub>cc</sub>	-	3.2	5.0	mA	At output OFF
Hall input hysteresis	V <sub>hys</sub>	± 3	-	±15	mV	
AL output L voltage	V <sub>AL</sub>	-	-	0.5	V	I <sub>AL</sub> =5mA
AL current capacity	I <sub>AL</sub>	8.0	-	-	mA	V <sub>AL</sub> =2V
Charge current of capacitor for lock detection	I <sub>LDC</sub>	2.0	3.45	5.25	μ A	V <sub>LD</sub> =1.5V
Discharge current of capacitor for lock detection	I <sub>LDD</sub>	0.35	0.80	1.45	μ A	V <sub>LD</sub> =1.5V
Charge-discharge current ratio of capacitor for lock detection	r <sub>CD</sub>	3	4.5	8	-	r <sub>CD</sub> =I <sub>LDC</sub> /I <sub>LDD</sub>
Clamp voltage of capacitor for lock detection	V <sub>LDCL</sub>	2.2	2.6	3.0	V	
Comparison voltage of capacitor for lock detection	V <sub>LDCLP</sub>	0.4	0.6	0.8	V	
Output H voltage	V <sub>OH</sub>	10	10.5	-	V	I <sub>o</sub> =10mA

● 特性データ(参考データ)

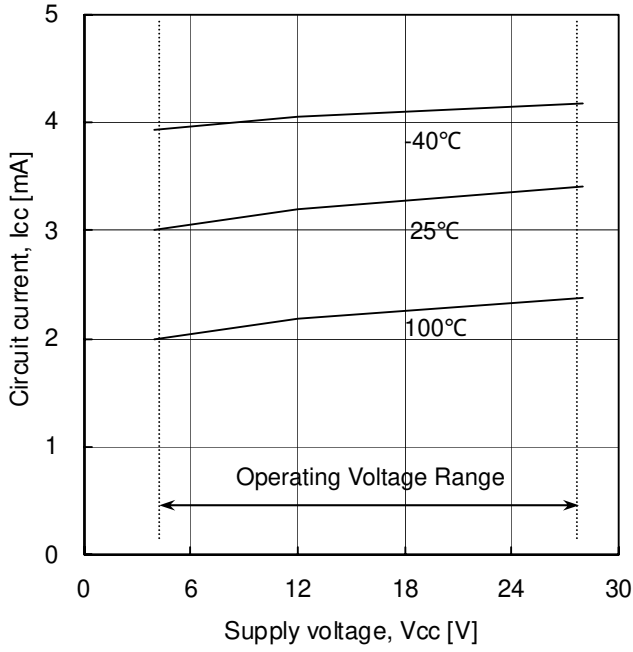

Fig.3 Circuit current

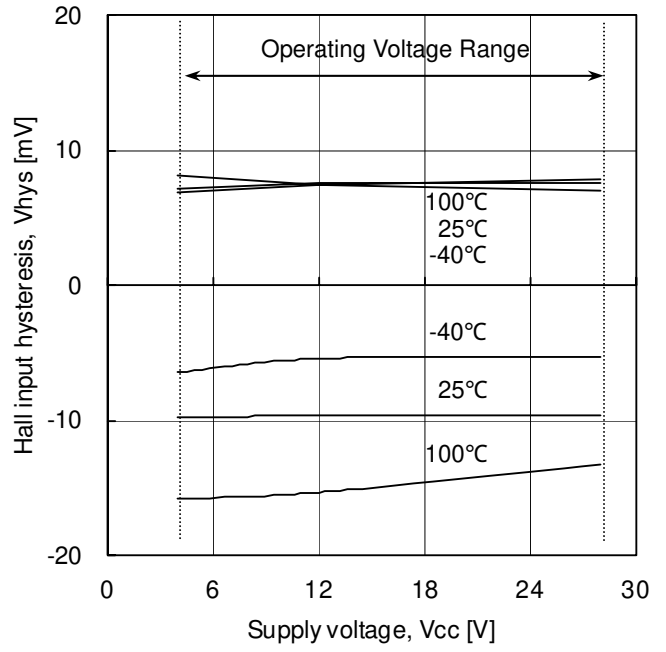

Fig.4 Hall input hysteresis

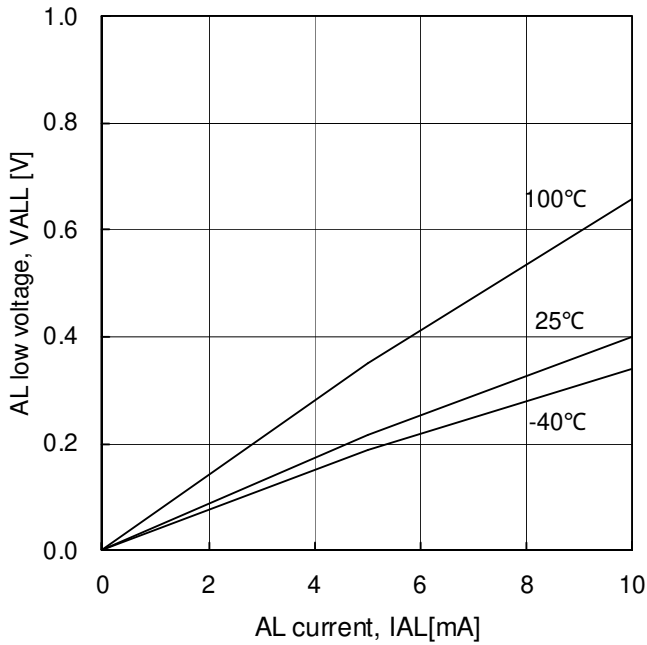

Fig.5 AL output L voltage

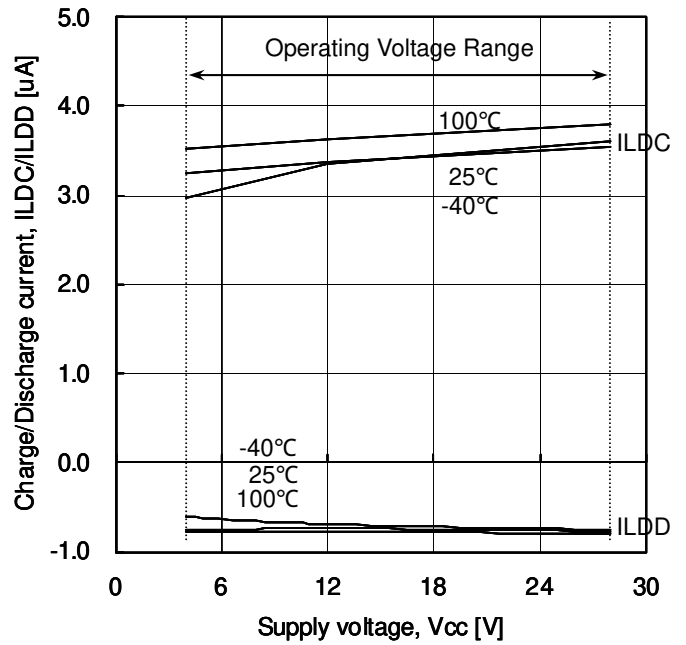

Fig.6 Charge-discharge current of capacitor for lock detection

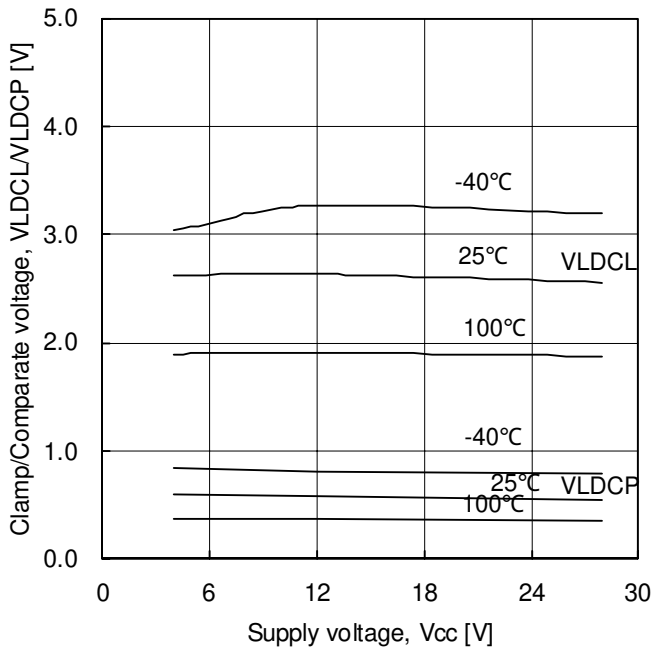

Fig.7 Clamp-comparison voltage of capacitor for lock detection

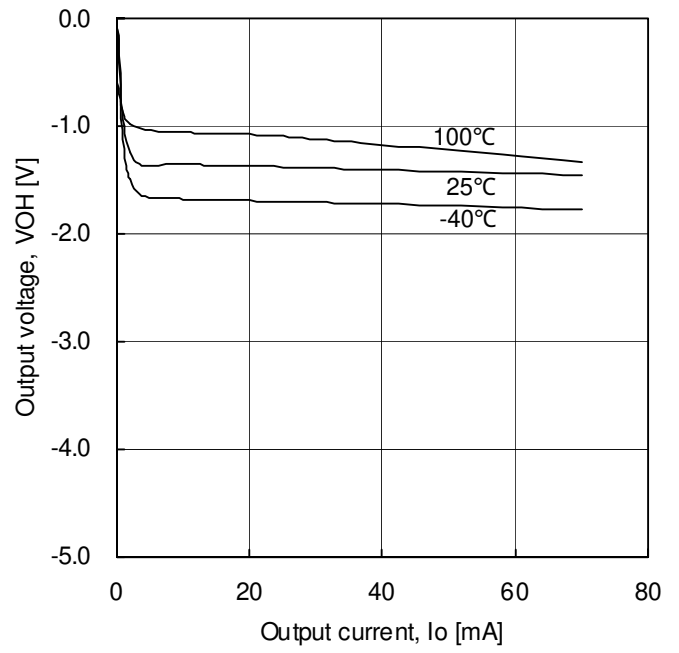

Fig.8 Output H voltage

• Application circuit example(Constant values are for reference)

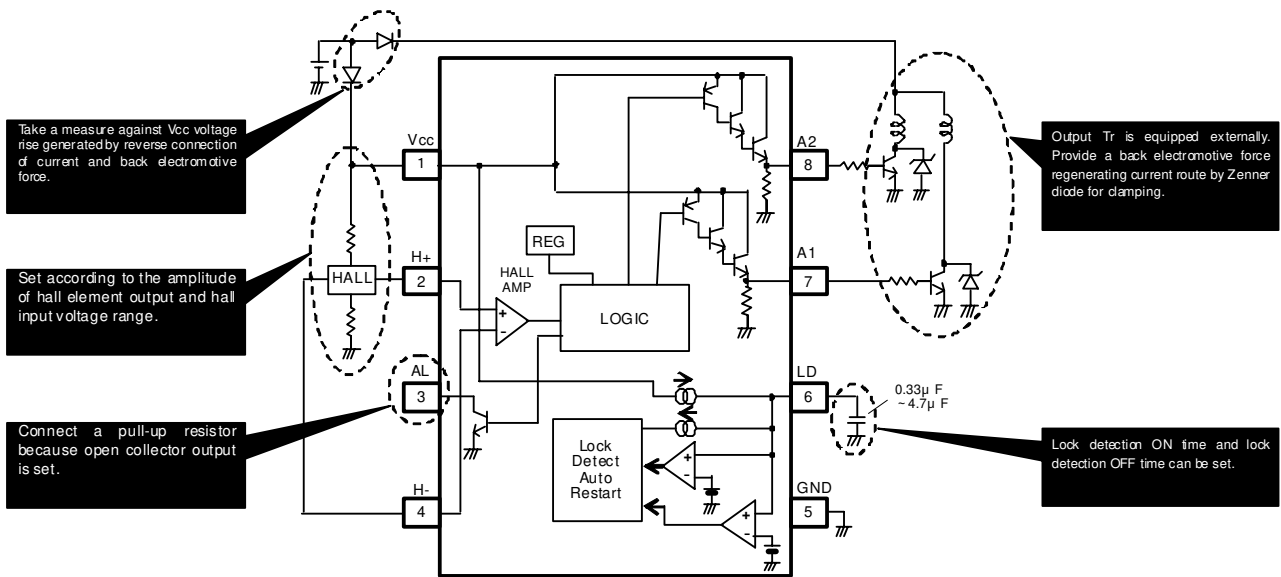

Fig.9 application circuit

**Substrate design note**

- IC power, motor outputs, and motor ground lines are made as fat as possible.
- IC ground (signal ground) line is common with the application ground except motor ground (i.e. hall ground etc.), and arranged near to (-) land.
- The bypass capacitor and/or Zener diode are arrangement near to Vcc terminal.
- H+ and H- lines are arranged side by side and made from the hall element to IC as shorter as possible, because it is easy for the noise to influence the hall lines.

• Description of operations

1) Lock protection and automatic restart

- CR timer system

Charging and discharging time at LD terminal depends on the capacitor equipped externally on LD terminal. Charging and discharging time is determined as follows:

$$TON(\text{charging time}) = \frac{C \times (VLDCL - VLDCP)}{ILDC}$$

$$TOFF(\text{discharging time}) = \frac{C \times (VLDCL - VLDCP)}{ILDD}$$

- C : Capacity of capacitor equipped externally on LD terminal
- VLDCL : LD terminal clamping voltage
- VLDCP : LD terminal comparator voltage
- ILDC : LD terminal charging current
- ILDD : LD terminal discharging current

Timing chart of LD terminal is shown in Fig.10.

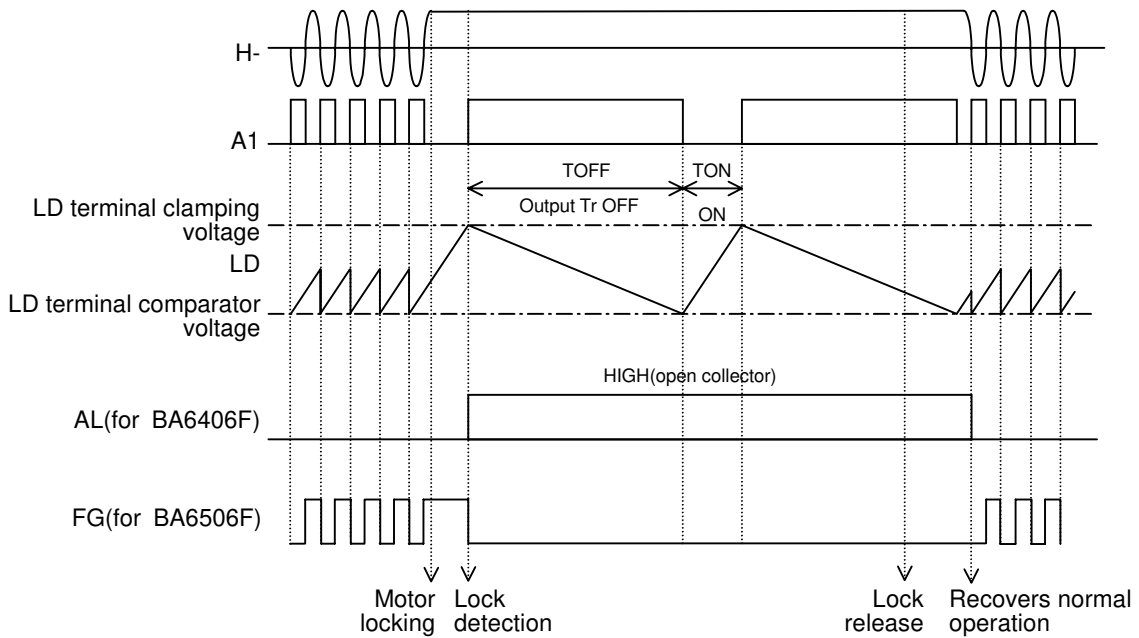

Fig.10 Lock protection (CR timer system) timing chart

● Thermal derating curve

Power dissipation (total loss) indicates the power that can be consumed by IC at Ta = 25°C (normal temperature). IC is heated when it consumes power, and the temperature of IC chip becomes higher than ambient temperature. The temperature that can be accepted by IC chip depends on circuit configuration, manufacturing process, etc, and consumable power is limited. Power dissipation is determined by the temperature allowed in IC chip (maximum junction temperature) and thermal resistance of package (heat dissipation capability). The maximum junction temperature is in general equal to the maximum value in the storage temperature range.

Heat generated by consumed power of IC is radiated from the mold resin or lead frame of package. The parameter which indicates this heat dissipation capability (hardness of heat release) is called heat resistance, represented by the symbol  $\theta_{ja}$  [°C/W]. The temperature of IC inside the package can be estimated by this heat resistance. Fig.11 shows the model of heat resistance of the package.

Heat resistance  $\theta_{ja}$ , ambient temperature Ta, junction temperature Tj, and power consumption P can be calculated by the equation below:

$$\theta_{ja} = (T_j - T_a) / P \quad [^{\circ}\text{C}/\text{W}]$$

Thermal derating curve indicates power that can be consumed by IC with reference to ambient temperature. Power that can be consumed by IC begins to attenuate at certain ambient temperature. This gradient is determined by thermal resistance  $\theta_{ja}$ .

Thermal resistance  $\theta_{ja}$  depends on chip size, power consumption, package ambient temperature, packaging condition, wind velocity, etc., even when the same package is used. Thermal derating curve indicates a reference value measured at a specified condition. Fig.56 shows a thermal derating curve (Value when mounting FR4 glass epoxy board 70 [mm] x 70 [mm] x 1.6 [mm] (copper foil area below 3 [%]))

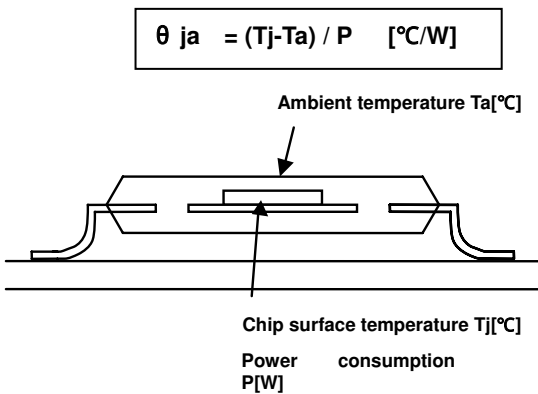
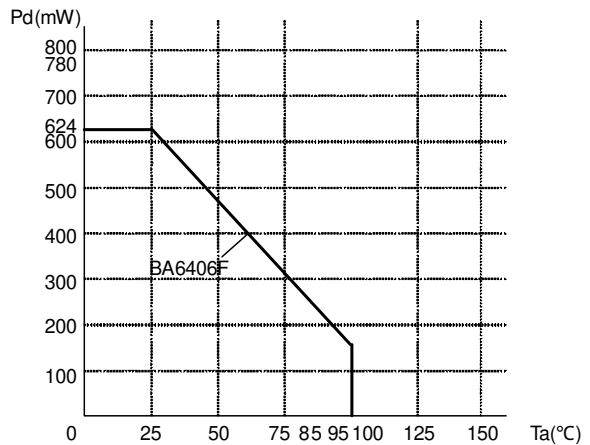

Fig.11 Thermal resistance



\* Reduce by 6.24 mW/°C over 25°C.  
(70.0mm x 70.0mm x 1.6mm glass epoxy board)

Fig.12 Thermal derating curve

● Equivalent circuit

1) Hall input terminal

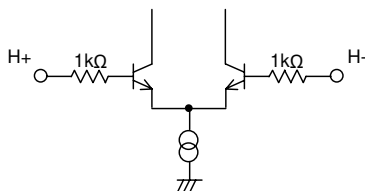

2) Output terminal

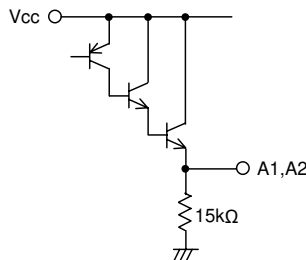

3)AL signal output terminal

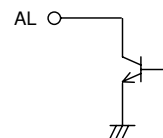



• Safety measure

1) Reverse connection protection diode

Reverse connection of power results in IC destruction as shown in Fig 13. When reverse connection is possible, reverse connection protection diode must be added between power supply and Vcc.

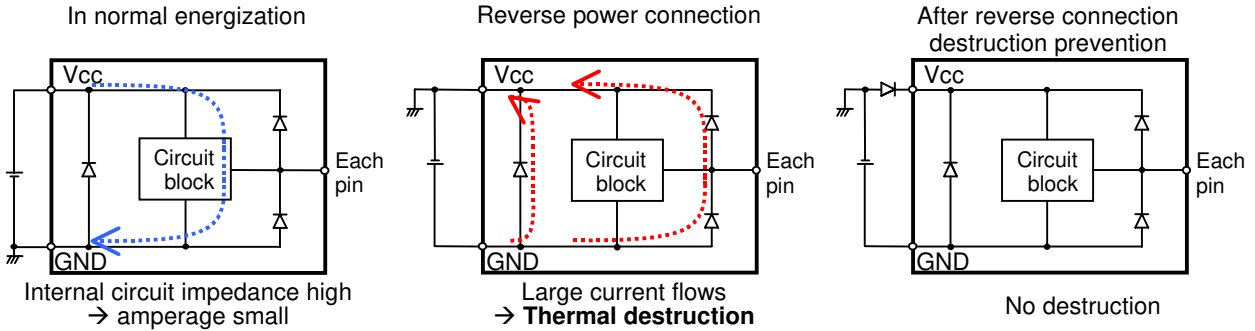

Fig.13 Current flow when power is connected reversely

2) About measures of voltage rise by back electromotive force

The voltage of output terminal rises by back electromotive force. The diode D1 of Fig.14 is necessary to divide a power supply line of motor with small signal line, so that the voltage of the output does not affect a power supply line.

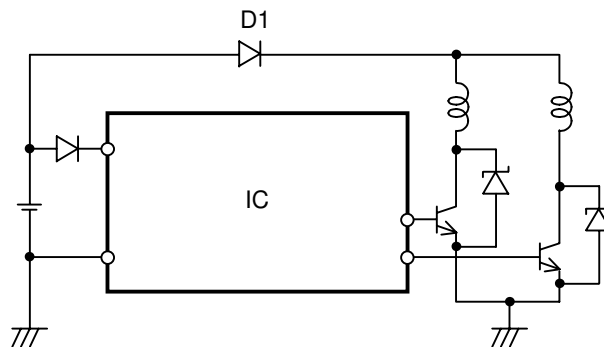

Fig.14 Separation of a power supply line

3) AL output

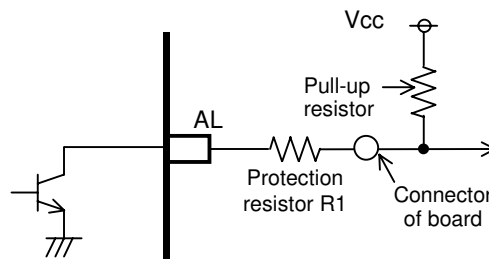

Fig.15 Protection of AL terminal

AL output is an open collector and requires pull-up resistor.

The IC can be protected by adding resistor R1. An excess of absolute maximum rating, when AL output terminal is directly connected to power supply, could damage the IC.

## 4) Problem of GND line PWM switching

Do not perform PWM switching of GND line because GND terminal potential cannot be kept to a minimum.

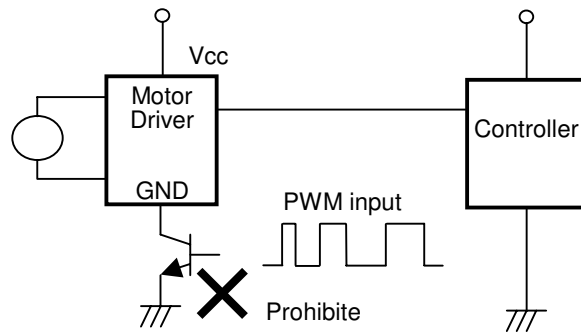

Fig.16 GND Line PWM switching prohibited

**• Operational Notes**

- 1) Absolute maximum ratings  
An excess in the absolute maximum ratings, such as supply voltage, temperature range of operating conditions, etc., can break down the devices, thus making impossible to identify breaking mode, such as a short circuit or an open circuit. If any over rated values will expect to exceed the absolute maximum ratings, consider adding circuit protection devices, such as fuses.
- 2) Connecting the power supply connector backward  
Connecting of the power supply in reverse polarity can damage IC. Take precautions when connecting the power supply lines. An external direction diode can be added.
- 3) Power supply line  
Back electromotive force causes regenerated current to power supply line, therefore take a measure such as placing a capacitor between power supply and GND for routing regenerated current. And fully ensure that the capacitor characteristics have no problem before determine a capacitor value. (when applying electrolytic capacitors, capacitance characteristic values are reduced at low temperatures)
- 4) GND potential  
The potential of GND pin must be minimum potential in all operating conditions. Also ensure that all terminals except GND terminal do not fall below GND voltage including transient characteristics. However, it is possible that the motor output terminal may deflect below GND because of influence by back electromotive force of motor. Malfunction may possibly occur depending on use condition, environment, and property of individual motor. Please make fully confirmation that no problem is found on operation of IC.
- 5) Thermal design  
Use a thermal design that allows for a sufficient margin in light of the power dissipation(Pd) in actual operating conditions.
- 6) Inter-pin shorts and mounting errors  
Use caution when positioning the IC for mounting on printed circuit boards. The IC may be damaged if there is any connection error or if pins are shorted together.
- 7) Actions in strong electromagnetic field  
Use caution when using the IC in the presence of a strong electromagnetic field as doing so may cause the IC to malfunction.
- 8) ASO  
When using the IC, set the output transistor so that it does not exceed absolute maximum ratings or ASO.
- 9) Testing on application boards  
When testing the IC on an application board, connecting a capacitor to a pin with low impedance subjects the IC to stress. Always discharge capacitors after each process or step. Always turn the IC's power supply off before connecting it to or removing it from a jig or fixture during the inspection process. Ground the IC during assembly steps as an antistatic measure. Use similar precaution when transporting or storing the IC.
- 10) GND wiring pattern  
When using both small signal and large current GND patterns, it is recommended to isolate the two ground patterns, placing a single ground point at the ground potential of application so that the pattern wiring resistance and voltage variations caused by large currents do not cause variations in the small signal ground voltage. Be careful not to change the GND wiring pattern of any external components, either.
- 11) Capacitor between output and GND  
When a large capacitor is connected between output and GND, if Vcc is shorted with 0V or GND for some cause, it is possible that the current charged in the capacitor may flow into the output resulting in destruction. Keep the capacitor between output and GND below 100uF.
- 12) IC terminal input  
When Vcc voltage is not applied to IC, do not apply voltage to each input terminal. When voltage above Vcc or below GND is applied to the input terminal, parasitic element is actuated due to the structure of IC. Operation of parasitic element causes mutual interference between circuits, resulting in malfunction as well as destruction in the last. Do not use in a manner where parasitic element is actuated.

• Physical dimension tape and reel information

SOP8

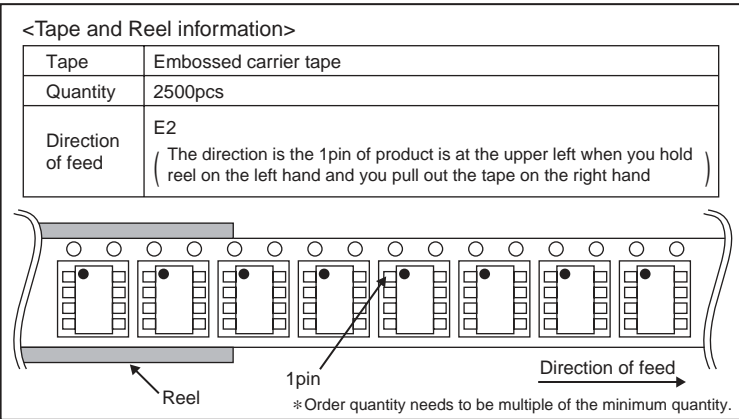
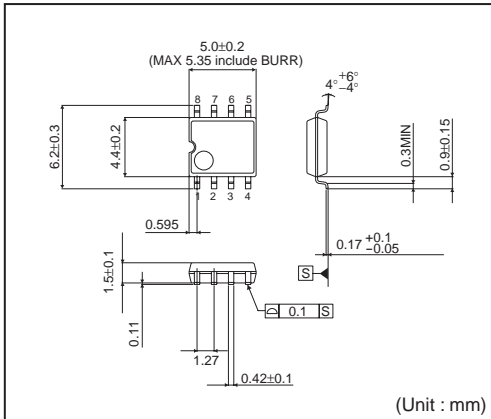

• Marking diagram

SOP8  
(TOP VIEW)

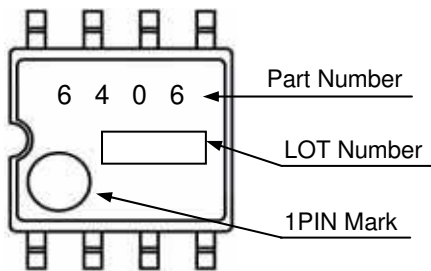

# Notice

## Precaution on using ROHM Products

- Our Products are designed and manufactured for application in ordinary electronic equipments (such as AV equipment, OA equipment, telecommunication equipment, home electronic appliances, amusement equipment, etc.). If you intend to use our Products in devices requiring extremely high reliability (such as medical equipment <sup>(Note 1)</sup>, transport equipment, traffic equipment, aircraft/spacecraft, nuclear power controllers, fuel controllers, car equipment including car accessories, safety devices, etc.) and whose malfunction or failure may cause loss of human life, bodily injury or serious damage to property ("Specific Applications"), please consult with the ROHM sales representative in advance. Unless otherwise agreed in writing by ROHM in advance, ROHM shall not be in any way responsible or liable for any damages, expenses or losses incurred by you or third parties arising from the use of any ROHM's Products for Specific Applications.

(Note1) Medical Equipment Classification of the Specific Applications

JAPAN	USA	EU	CHINA
CLASS III	CLASS III	CLASS II b	CLASS III
CLASS IV		CLASS III	

- ROHM designs and manufactures its Products subject to strict quality control system. However, semiconductor products can fail or malfunction at a certain rate. Please be sure to implement, at your own responsibilities, adequate safety measures including but not limited to fail-safe design against the physical injury, damage to any property, which a failure or malfunction of our Products may cause. The following are examples of safety measures:
  - Installation of protection circuits or other protective devices to improve system safety
  - Installation of redundant circuits to reduce the impact of single or multiple circuit failure
- Our Products are designed and manufactured for use under standard conditions and not under any special or extraordinary environments or conditions, as exemplified below. Accordingly, ROHM shall not be in any way responsible or liable for any damages, expenses or losses arising from the use of any ROHM's Products under any special or extraordinary environments or conditions. If you intend to use our Products under any special or extraordinary environments or conditions (as exemplified below), your independent verification and confirmation of product performance, reliability, etc. prior to use, must be necessary:
  - Use of our Products in any types of liquid, including water, oils, chemicals, and organic solvents
  - Use of our Products outdoors or in places where the Products are exposed to direct sunlight or dust
  - Use of our Products in places where the Products are exposed to sea wind or corrosive gases, including Cl<sub>2</sub>, H<sub>2</sub>S, NH<sub>3</sub>, SO<sub>2</sub>, and NO<sub>2</sub>
  - Use of our Products in places where the Products are exposed to static electricity or electromagnetic waves
  - Use of our Products in proximity to heat-producing components, plastic cords, or other flammable items
  - Sealing or coating our Products with resin or other coating materials
  - Use of our Products without cleaning residue of flux (even if you use no-clean type fluxes, cleaning residue of flux is recommended); or Washing our Products by using water or water-soluble cleaning agents for cleaning residue after soldering
  - Use of the Products in places subject to dew condensation
- The Products are not subject to radiation-proof design.
- Please verify and confirm characteristics of the final or mounted products in using the Products.
- In particular, if a transient load (a large amount of load applied in a short period of time, such as pulse. is applied, confirmation of performance characteristics after on-board mounting is strongly recommended. Avoid applying power exceeding normal rated power; exceeding the power rating under steady-state loading condition may negatively affect product performance and reliability.
- De-rate Power Dissipation (Pd) depending on Ambient temperature (Ta). When used in sealed area, confirm the actual ambient temperature.
- Confirm that operation temperature is within the specified range described in the product specification.
- ROHM shall not be in any way responsible or liable for failure induced under deviant condition from what is defined in this document.

## Precaution for Mounting / Circuit board design

- When a highly active halogenous (chlorine, bromine, etc.) flux is used, the residue of flux may negatively affect product performance and reliability.
- In principle, the reflow soldering method must be used; if flow soldering method is preferred, please consult with the ROHM representative in advance.

For details, please refer to ROHM Mounting specification

### Precautions Regarding Application Examples and External Circuits

1. If change is made to the constant of an external circuit, please allow a sufficient margin considering variations of the characteristics of the Products and external components, including transient characteristics, as well as static characteristics.
2. You agree that application notes, reference designs, and associated data and information contained in this document are presented only as guidance for Products use. Therefore, in case you use such information, you are solely responsible for it and you must exercise your own independent verification and judgment in the use of such information contained in this document. ROHM shall not be in any way responsible or liable for any damages, expenses or losses incurred by you or third parties arising from the use of such information.

### Precaution for Electrostatic

This Product is electrostatic sensitive product, which may be damaged due to electrostatic discharge. Please take proper caution in your manufacturing process and storage so that voltage exceeding the Products maximum rating will not be applied to Products. Please take special care under dry condition (e.g. Grounding of human body / equipment / solder iron, isolation from charged objects, setting of Ionizer, friction prevention and temperature / humidity control).

### Precaution for Storage / Transportation

1. Product performance and soldered connections may deteriorate if the Products are stored in the places where:
  - [a] the Products are exposed to sea winds or corrosive gases, including Cl<sub>2</sub>, H<sub>2</sub>S, NH<sub>3</sub>, SO<sub>2</sub>, and NO<sub>2</sub>
  - [b] the temperature or humidity exceeds those recommended by ROHM
  - [c] the Products are exposed to direct sunshine or condensation
  - [d] the Products are exposed to high Electrostatic
2. Even under ROHM recommended storage condition, solderability of products out of recommended storage time period may be degraded. It is strongly recommended to confirm solderability before using Products of which storage time is exceeding the recommended storage time period.
3. Store / transport cartons in the correct direction, which is indicated on a carton with a symbol. Otherwise bent leads may occur due to excessive stress applied when dropping of a carton.
4. Use Products within the specified time after opening a humidity barrier bag. Baking is required before using Products of which storage time is exceeding the recommended storage time period.

### Precaution for Product Label

QR code printed on ROHM Products label is for ROHM's internal use only.

### Precaution for Disposition

When disposing Products please dispose them properly using an authorized industry waste company.

### Precaution for Foreign Exchange and Foreign Trade act

Since our Products might fall under controlled goods prescribed by the applicable foreign exchange and foreign trade act, please consult with ROHM representative in case of export.

### Precaution Regarding Intellectual Property Rights

1. All information and data including but not limited to application example contained in this document is for reference only. ROHM does not warrant that foregoing information or data will not infringe any intellectual property rights or any other rights of any third party regarding such information or data. ROHM shall not be in any way responsible or liable for infringement of any intellectual property rights or other damages arising from use of such information or data.:
2. No license, expressly or implied, is granted hereby under any intellectual property rights or other rights of ROHM or any third parties with respect to the information contained in this document.

### Other Precaution

1. This document may not be reprinted or reproduced, in whole or in part, without prior written consent of ROHM.
2. The Products may not be disassembled, converted, modified, reproduced or otherwise changed without prior written consent of ROHM.
3. In no event shall you use in any way whatsoever the Products and the related technical information contained in the Products or this document for any military purposes, including but not limited to, the development of mass-destruction weapons.
4. The proper names of companies or products described in this document are trademarks or registered trademarks of ROHM, its affiliated companies or third parties.

**General Precaution**

1. Before you use our Products, you are requested to carefully read this document and fully understand its contents. ROHM shall not be in any way responsible or liable for failure, malfunction or accident arising from the use of any ROHM's Products against warning, caution or note contained in this document.
2. All information contained in this document is current as of the issuing date and subject to change without any prior notice. Before purchasing or using ROHM's Products, please confirm the latest information with a ROHM sales representative.
3. The information contained in this document is provided on an "as is" basis and ROHM does not warrant that all information contained in this document is accurate and/or error-free. ROHM shall not be in any way responsible or liable for any damages, expenses or losses incurred by you or third parties resulting from inaccuracy or errors of or concerning such information.