

General Description

The 8413S08 is a high performance PLL-based clock generator optimized for processor core, PCI/PCI-X/PCIe bus, SGMII and Gigabit Ethernet PHY clocks. The clock generator offers ultra-low jitter outputs that make it ideal to serve as a central clocking device for multiple clock destinations. The output frequencies are generated from a 25MHz parallel resonant crystal, or external differential input source. The industrial temperature range of the 8413S08 supports tele-communication, networking and storage requirements.

Features

- Eight selectable 100MHz or 125MHz clocks for PCI Express™ and sRIO, HCSL interface levels
- One 156.25MHz SGMII clock, LVPECL interface levels
- Three LVCMOS/LVTTL outputs, 20Ω output impedance
- Selectable external crystal or differential (single-ended) input source
- Crystal oscillator interface designed for 25MHz, parallel resonant crystal
- Differential CLK, nCLK input pair that can accept: LVPECL, LVDS, LVHSTL, HCSL input levels
- Internal resistor bias on nCLK pin allows the user to drive CLK input with external single-ended (LVCMOS/ LVTTL) input levels
- Output supply voltage modes:
 V_{DD} / V_{DDO}
 3.3V/3.3V
 3.3V/2.5V
- Full 3.3V output supply mode (HCSL)
- PCI Express™(2.5 Gb/s), Gen 2 (5 Gb/s), and Gen 3 (8 Gb/s) jitter compliant
- -40°C to 85°C ambient operating temperature
- Available in lead-free (RoHS 6) package

Pin Assignment

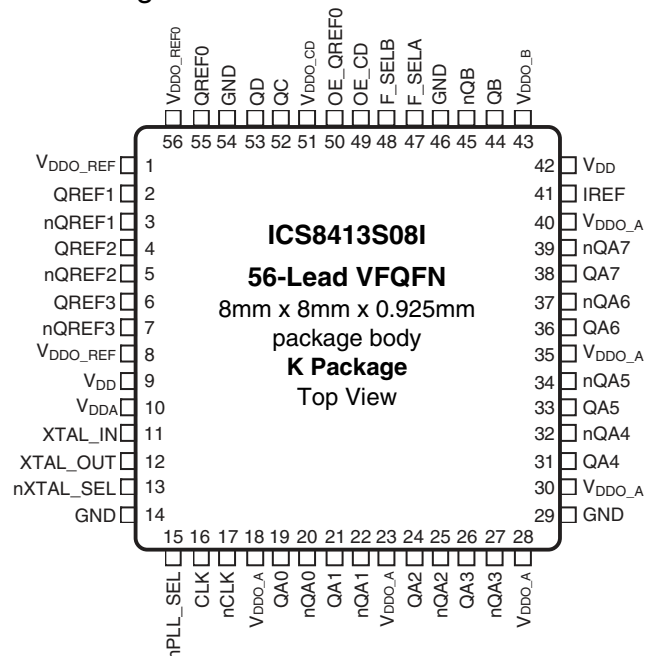

Block Diagram

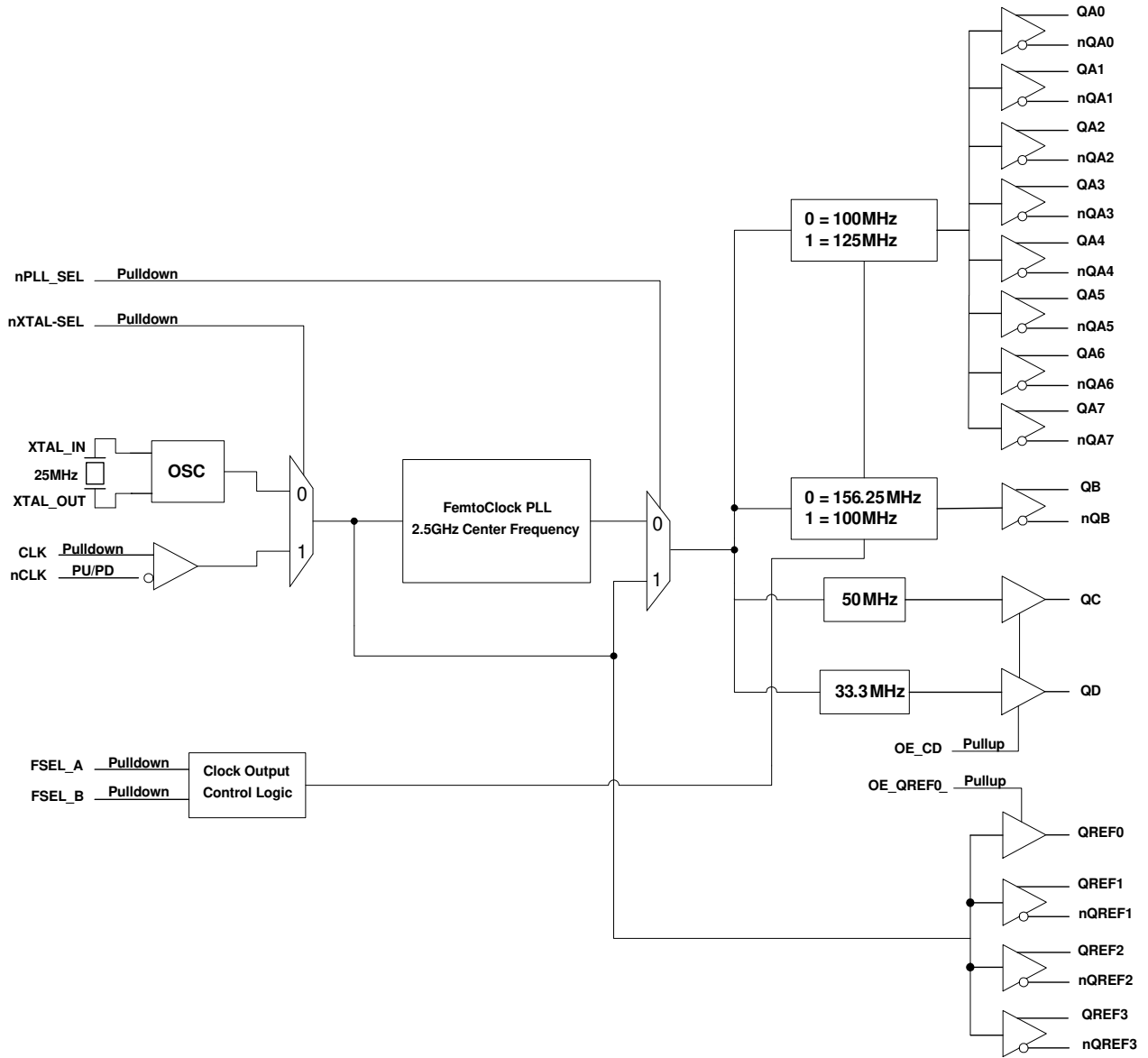

Table 1. Pin Descriptions

Number	Name	Type		Description
1, 8	V _{DDO_REF}	Power		QREF[1:3], nQREF[1:3] (LVPECL) output supply pins. 3.3V or 2.5V supply.
2, 3	QREF1, nQREF1	Output		Differential reference output pair. 3.3V or 2.5V LVPECL interface levels.
4, 5	QREF2, nQREF2	Output		Differential reference output pair. 3.3V or 2.5V LVPECL interface levels.
6, 7	QREF3, nQREF3	Output		Differential reference output pair. 3.3V or 2.5V LVPECL interface levels.
9, 42	V _{DD}	Power		Core supply pins.
10	V _{DDA}	Power		Analog supply pin.
11, 12	XTAL_IN, XTAL_OUT	Input		Parallel resonant crystal interface. XTAL_OUT is the output, XTAL_IN is the input.
13	nXTAL_SEL	Input	Pulldown	Input source control pin. See Table 3D. LVCMOS/LVTTL interface levels.
14, 29, 46, 54	GND	Power		Power supply ground.
15	nPLL_SEL	Input	Pulldown	PLL bypass control pin. See Table 3C. LVCMOS/LVTTL interface levels.
16	CLK	Input	Pulldown	Non-inverting differential clock input.
17	nCLK	Input	Pullup/ Pulldown	Inverting differential clock input. Internal resistor bias to V _{DD} /2.
18, 23, 28, 30, 35, 40	V _{DDO_A}	Power		Bank A (HCSL) output supply pins. 3.3V supply.
19, 20	QA0, nQA0	Output		Differential output pair. HCSL interface levels.
21, 22	QA1, nQA1	Output		Differential output pair. HCSL interface levels.
24, 25	QA2, nQA2	Output		Differential output pair. HCSL interface levels.
26, 27	QA3, nQA3	Output		Differential output pair. HCSL interface levels.
31, 32	QA4, nQA4	Output		Differential output pair. HCSL interface levels.
33, 34	QA5, nQA5	Output		Differential output pair. HCSL interface levels.
36, 37	QA6, nQA6	Output		Differential output pair. HCSL interface levels.
38, 39	QA7, nQA7	Output		Differential output pair. HCSL interface levels.
41	I _{REF}	Input		External fixed precision resistor (475Ω) from this pin to ground provides a reference current used for differential current-mode QAx, nQAx outputs.
43	V _{DDO_B}	Power		Bank B (LVPECL) output supply pin. 3.3V or 2.5V supply.
44, 45	QB, nQB	Output		Differential output pair. 3.3V or 2.5V LVPECL interface levels.
47	F_SELA	Input	Pulldown	Selects the QAx, nQAx output frequency. See Table 3A. LVCMOS/LVTTL interface levels.
48	F_SELB	Input	Pulldown	Selects the QB output frequency. See Table 3B. LVCMOS/LVTTL interface levels.
49	OE_CD	Input	Pullup	Active HIGH output enable for Bank C and Bank D outputs. See Table 3E. LVCMOS/LVTTL interface levels.
50	OE_QREF0	Input	Pullup	Active HIGH output enable for QREF0 output. See Table 3F. LVCMOS/LVTTL interface levels.

Pin Descriptions continues on next page.

Number	Name	Type	Description
51	V _{DDO_CD}	Power	Bank C and D (LVCMOS) output supply pin. 3.3V or 2.5V supply.
52	QC	Output	Single-ended output. 3.3V or 2.5V LVCMOS/LVTTL interface levels.
53	QD	Output	Single-ended output. 3.3V or 2.5V LVCMOS/LVTTL interface levels.
55	QREF0	Output	Single-ended reference output. 3.3V or 2.5V LVCMOS/LVTTL interface levels.
56	V _{DDO_REF0}	Power	QREF0 (LVCMOS) output supply pin. 3.3V or 2.5V supply.

NOTE: Pullup and Pulldown refer to internal input resistors. See Table 2, *Pin Characteristics*, for typical values.

Table 2. Pin Characteristics

Symbol	Parameter	Test Conditions	Minimum	Typical	Maximum	Units
C _{IN}	Input Capacitance			2		pF
C _{PD}	Power Dissipation Capacitance (per output)	V _{DD} , V _{DDO_A} , V _{DDO_B} , V _{DDO_CD} , V _{DDO_QREF0} , V _{DDO_QREF} = 3.465V		4		pF
		V _{DD} = 3.465V, V _{DDO_B} , V _{DDO_CD} , V _{DDO_QREF0} = 2.625V		4		pF
R _{PULLUP}	Input Pullup Resistor			51		kΩ
R _{PULLDOWN}	Input Pulldown Resistor			51		kΩ
R _{OUT}	Output Impedance	QC, QD, QREF0 V _{DDO_CD} , V _{DDO_QREF0} = 3.465V		20		Ω
		QC, QD, QREF0 V _{DDO_CD} , V _{DDO_QREF0} = 2.625V		25		Ω

Function Tables

Table 3A. QAx, nQAx Control Input Function Table

Input	Output Frequency
FSEL_A	QAx, nQAx[0:7]
0 (default)	100MHz
1	125MHz

Table 3B. QB, nQB Control Input Function Table

Input	Output Frequency
FSEL_B	QB, nQB
0 (default)	156.25MHz
1	100MHz

Table 3C. nPLL_SEL Control Input Function Table

Input	Operation
nPLL_SEL	
0 (default)	PLL Mode
1	PLL Bypass

Table 3D. nXTAL_SEL Control Input Function Table

Input	Clock Source
nXTAL_SEL	
0 (default)	XTAL_IN, XTAL_OUT
1	CLK, nCLK

Table 3E. OE_CD Control Input Function Table

Input	Outputs
OE_CD	QC, QD
0	High-Impedance
1(default)	Enabled

Table 3F. OE_QREF0 Control Input Function Table

Input	Output
OE_QREF0	QREF0
0	High-Impedance
1(default)	Enabled

Absolute Maximum Ratings

NOTE: Stresses beyond those listed under *Absolute Maximum Ratings* may cause permanent damage to the device. These ratings are stress specifications only. Functional operation of product at these conditions or any conditions beyond those listed in the *DC Characteristics* or *AC Characteristics* is not implied. Exposure to absolute maximum rating conditions for extended periods may affect product reliability.

Item	Rating
Supply Voltage, V_{DD}	4.6V
Inputs, V_I XTAL_in Other Inputs	-0.5V to $V_{DD} + 0.5V$ 0V to V_{DD} -0.5V to $V_{DD} + 0.5V$
Outputs, V_O (LVCMOS)	-0.5V to $V_{DD} + 0.5V$
Outputs, I_O (HCSL) Continuos Current Surge Current	10mA 15mA
Outputs, I_O (LVPECL) Continuos Current Surge Current	50mA 100mA
Package Thermal Impedance, θ_{JA}	31.4°C/W (0 mps)
Storage Temperature, T_{STG}	-65°C to 150°C

DC Electrical Characteristics

Table 4A. Power Supply DC Characteristics, $V_{DD} = V_{DDO_X} = 3.3V \pm 5\%$, $T_A = -40^\circ C$ to $85^\circ C$

Symbol	Parameter	Test Conditions	Minimum	Typical	Maximum	Units
V_{DD}	Core Supply Voltage		3.135	3.3	3.465	V
V_{DDA}	Analog Supply Voltage		$V_{DD} - 0.16$	3.3	V_{DD}	V
V_{DDO_X}	Output Supply Voltage		3.135	3.3	3.465	V
I_{DD}	Power Supply Current				84	mA
I_{DDA}	Analog Supply Current				16	mA
I_{DDO_X}	Output Supply Current	No Load, CLK selected			66	mA

NOTE: V_{DDO_X} denotes V_{DDO_A} , V_{DDO_B} , V_{DDO_CD} , V_{DDO_QREF0} , V_{DDO_QREF} .

NOTE: I_{DDO_X} denotes I_{DDO_A} , I_{DDO_B} , I_{DDO_CD} , I_{DDO_QREF0} , I_{DDO_QREF} .

Table 4B. Power Supply DC Characteristics, $V_{DD} = 3.3V \pm 5\%$, $V_{DDO_X} = 2.5V \pm 5\%$, $T_A = -40^\circ C$ to $85^\circ C$

Symbol	Parameter	Test Conditions	Minimum	Typical	Maximum	Units
V_{DD}	Core Supply Voltage		3.135	3.3	3.465	V
V_{DDA}	Analog Supply Voltage		$V_{DD} - 0.16$	3.3	V_{DD}	V
V_{DDO_X}	Output Supply Voltage		2.375	2.5	2.625	V
I_{DD}	Power Supply Current				84	mA
I_{DDA}	Analog Supply Current				16	mA
I_{DDO_X}	Output Supply Current	No Load, CLK selected			54	mA

NOTE: V_{DDO_X} denotes V_{DDO_B} , V_{DDO_CD} , V_{DDO_QREF0} , V_{DDO_QREF} .

NOTE: I_{DDO_X} denotes I_{DDO_B} , I_{DDO_CD} , I_{DDO_QREF0} , I_{DDO_QREF} .

Table 4C. LVCMOS/LVTTL DC Characteristics, $V_{DD} = 3.3V \pm 5\%$, $V_{DDO_X} = 3.3V \pm 5\%$ or $2.5V \pm 5\%$, $T_A = -40^\circ\text{C}$ to 85°C

Symbol	Parameter	Test Conditions	Minimum	Typical	Maximum	Units
V_{IH}	Input High Voltage		2.2		$V_{DD} + 0.3$	V
V_{IL}	Input Low Voltage		-0.3		0.8	V
I_{IH}	Input High Current	FSEL_A, FSEL_B, nXTAL_SEL, nPLL_SEL	$V_{DD} = V_{IN} = 3.465V$		150	μA
		OE_CD, OE_QREF0	$V_{DD} = V_{IN} = 3.465V$		10	μA
I_{IL}	Input Low Current	FSEL_A, FSEL_B, nXTAL_SEL, nPLL_SEL	$V_{DD} = 3.465V, V_{IN} = 0V$	-10		μA
		OE_CD, OE_QREF0	$V_{DD} = 3.465V, V_{IN} = 0V$	-150		μA
V_{OH}	Output High Voltage; NOTE 1		$V_{DDO_X} = 3.465V$	2.6		V
			$V_{DDO_X} = 2.625V$	1.8		V
V_{OL}	Output Low Voltage; NOTE 1		$V_{DDO_X} = 3.465V$ or $2.625V$		0.5	V

NOTE: V_{DDO_X} denotes V_{DDO_CD} , V_{DDO_QREF0} .

NOTE 1: Outputs terminated with 50Ω to $V_{DDO_X}/2$. See Parameter Measurement Information, *Output Load Test Circuit diagrams*.

Table 4D. Differential DC Characteristics, $V_{DD} = 3.3V \pm 5\%$, $T_A = -40^\circ\text{C}$ to 85°C

Symbol	Parameter	Test Conditions	Minimum	Typical	Maximum	Units
I_{IH}	Input High Current	CLK, nCLK	$V_{DD} = V_{IN} = 3.465V$		150	μA
I_{IL}	Input Low Current	CLK	$V_{DD} = 3.465V, V_{IN} = 0V$	-10		μA
		nCLK	$V_{DD} = 3.465V, V_{IN} = 0V$	-150		μA
V_{PP}	Peak-to-Peak Input Voltage; NOTE 1		0.15		1.3	V
V_{CMR}	Common Mode Input Voltage; NOTE 1, 2		0.5		$V_{DD} - 0.85$	V

NOTE 1: V_{IL} should not be less than -0.3V.

NOTE 2: Common mode voltage is defined as V_{IH} .

Table 4E. LVPECL DC Characteristics, $V_{DD} = V_{DDO_B} = V_{DDO_REF} = 3.3V \pm 5\%$, $T_A = -40^\circ\text{C}$ to 85°C

Symbol	Parameter	Test Conditions	Minimum	Typical	Maximum	Units
V_{OH}	Output High Voltage; NOTE 1		$V_{DDO_X} - 1.4$		$V_{DDO_X} - 0.9$	V
V_{OL}	Output Low Voltage; NOTE 1		$V_{DDO_X} - 2.0$		$V_{DDO_X} - 1.7$	V
V_{SWING}	Peak-to-Peak Output Voltage Swing		0.6		1.0	V

NOTE 1: Outputs terminated with 50Ω to $V_{DDO_X} - 2V$.

Table 4F. LVPECL DC Characteristics, $V_{DD} = 3.3V \pm 5\%$, $V_{DDO_B} = V_{DDO_REF} = 2.5V \pm 5\%$, $T_A = -40^\circ\text{C}$ to 85°C

Symbol	Parameter	Test Conditions	Minimum	Typical	Maximum	Units
V_{OH}	Output High Voltage; NOTE 1		$V_{DDO_X} - 1.4$		$V_{DDO_X} - 0.9$	V
V_{OL}	Output Low Voltage; NOTE 1		$V_{DDO_X} - 2.0$		$V_{DDO_X} - 1.5$	V
V_{SWING}	Peak-to-Peak Output Voltage Swing		0.4		1.0	V

NOTE 1: Outputs terminated with 50Ω to $V_{DDO_X} - 2V$.

Table 5. Crystal Characteristics

Parameter	Test Conditions	Minimum	Typical	Maximum	Units
Mode of Oscillation		Fundamental			
Frequency			25		MHz
Equivalent Series Resistance (ESR)				50	Ω
Shunt Capacitance				7	pF

NOTE: Characterized using an 18pF parallel resonant crystal.

AC Electrical Characteristics

Table 6A. PCI Express Jitter Specifications, $V_{DD} = 3.3V \pm 5\%$, $V_{DDO_X} = 3.3V \pm 5\%$ or $2.5V \pm 5\%$, $T_A = -40^\circ\text{C}$ to 85°C

Symbol	Parameter	Test Conditions	Minimum	Typical	Maximum	PCIe Industry Specification	Units
t_j (PCIe Gen 1)	Phase Jitter Peak-to-Peak; NOTE 1, 4	$f = 100\text{MHz}$, 25MHz Crystal Input Evaluation Band: 0Hz - Nyquist (clock frequency/2)		11.51	17.45	86	ps
$t_{\text{REFCLK_HF_RMS}}$ (PCIe Gen 2)	Phase Jitter RMS; NOTE 2, 4	$f = 100\text{MHz}$, 25MHz Crystal Input High Band: 1.5MHz - Nyquist (clock frequency/2)		1.08	1.67	3.10	ps
$t_{\text{REFCLK_LF_RMS}}$ (PCIe Gen 2)	Phase Jitter RMS; NOTE 2, 4	$f = 100\text{MHz}$, 25MHz Crystal Input Low Band: 10kHz - 1.5MHz		0.06	0.11	3.0	ps
$t_{\text{REFCLK_RMS}}$ (PCIe Gen 3)	Phase Jitter RMS; NOTE 3, 4	$f = 100\text{MHz}$, 25MHz Crystal Input Evaluation Band: 0Hz - Nyquist (clock frequency/2)		0.26	0.38	0.8	ps

NOTE: Electrical parameters are guaranteed over the specified ambient operating temperature range, which is established when the device is mounted in a test socket with maintained transverse airflow greater than 500 lfm. The device will meet specifications after thermal equilibrium has been reached under these conditions. For additional information, refer to the *PCI Express Application Note section* in the datasheet.

NOTE 1: Peak-to-Peak jitter after applying system transfer function for the Common Clock Architecture. Maximum limit for PCI Express Gen 1 is 86ps peak-to-peak for a sample size of 10^6 clock periods.

NOTE 2: RMS jitter after applying the two evaluation bands to the two transfer functions defined in the Common Clock Architecture and reporting the worst case results for each evaluation band. Maximum limit for PCI Express Generation 2 is 3.1ps RMS for $t_{\text{REFCLK_HF_RMS}}$ (High Band) and 3.0ps RMS for $t_{\text{REFCLK_LF_RMS}}$ (Low Band).

NOTE 3: RMS jitter after applying system transfer function for the common clock architecture. This specification is based on the *PCI Express Base Specification Revision 0.7, October 2009* and is subject to change pending the final release version of the specification.

NOTE 4: This parameter is guaranteed by characterization. Not tested in production.

Table 6B. AC Characteristics, $V_{DD} = 3.3V \pm 5\%$, $V_{DDO_X} = 3.3V \pm 5\%$ or $2.5V \pm 5\%$, $T_A = -40^{\circ}C$ to $85^{\circ}C$

Symbol	Parameter	Test Conditions	Minimum	Typical	Maximum	Units
f_{OUT}	Output Frequency	QB, nQB	FSEL_B = 0	156.25		MHz
			FSEL_B = 1	100		MHz
		QC		50		MHz
		QD		33.333		MHz
$t_{jit(cc)}$	Cycle-to-Cycle Jitter; NOTE 2, 3	QB, nQB		47	80	ps
		QC		155	200	ps
		QD		105	185	ps
$t_{jit(\emptyset)}$	RMS Phase Jitter, (Random); NOTE 1	QREF0	25MHz (10kHz to 5MHz)	0.61	0.82	ps
		QREF[1:3], nQREF[1:3]	25MHz (10kHz to 5MHz)	0.51	0.70	ps
		QB, nQB	156.25MHz (12kHz to 20MHz)	0.58	0.72	ps
t_R / t_F	Output Rise/Fall Time	QB, nQB	20% to 80%	110	225	ps
		QC, QD		400	1400	ps
		QREF0		400	1400	ps
		QREF[1:3] nQREF[1:3]		110	225	ps
odc	Output Duty Cycle	QB, nQB	measured at crosspoint	48	52	%
		QC, QD	measured at $V_{DDO_CD}/2$	48	52	%
		QREF0	measured at $V_{DDO_QREF0}/2$	45	55	%
		QREF[1:3], nQREF[1:3]	measured at crosspoint	45	55	%

NOTE: Electrical parameters are guaranteed over the specified ambient operating temperature range, which is established when the device is mounted in a test socket with maintained transverse airflow greater than 500 lfm. The device will meet specifications after thermal equilibrium has been reached under these conditions.

NOTE: V_{DDO_X} denotes V_{DDO_B} , V_{DDO_CD} , V_{DDO_QREF} and V_{DDO_QREF0} .

NOTE 1: Refer to the phase noise plots.

NOTE 2: This parameter is defined in accordance with JEDEC Standard 65.

NOTE 3: Jitter performance using XTAL inputs.

HCSL AC Electrical Characteristics

Table 6C. HCSL AC Characteristics, $V_{DD} = 3.3V \pm 5\%$, $V_{DDO_A} = 3.3V \pm 5\%$, $T_A = -40^\circ\text{C}$ to 85°C

Symbol	Parameter	Test Conditions	Minimum	Typical	Maximum	Units
f_{OUT}	Output Frequency	FSEL_A = 0		100		MHz
		FSEL_A = 1		125		MHz
$t_{jit(cc)}$	Cycle-to-Cycle Jitter; NOTE 1, 2			54	80	ps
$t_{sk(o)}$	Output Skew; NOTE 2, 3			30	100	ps
$t_{jit(\emptyset)}$	RMS Phase Jitter, (Random); NOTE 4	100MHz (1.875MHz to 20MHz)		0.29	0.37	ps
		100MHz (12kHz to 20MHz)		0.63	0.81	ps
V_{RB}	Ring-Back Voltage Margin; NOTE 5, 6		-100		100	mV
t_{STABLE}	Time before V_{RB} is allowed; NOTE 5, 6		500			ps
V_{MAX}	Absolute Max Output Voltage; NOTE 7, 8				1150	mV
V_{MIN}	Absolute Min Output Voltage; NOTE 7, 9		-300			mV
V_{CROSS}	Absolute Crossing Voltage; NOTE 7, 10, 11		250		550	mV
ΔV_{CROSS}	Total Variation of V_{CROSS} over All Edges; NOTE 7, 10, 12				140	mV
t_{SLEW+}	Rising Edge Rate; NOTE 5, 13		0.6		5.5	V/ns
t_{SLEW-}	Falling Edge Rate; NOTE 5, 13		0.6		5.5	V/ns
odc	Output Duty Cycle; NOTE 6		48		52	%

NOTE: Electrical parameters are guaranteed over the specified ambient operating temperature range, which is established when the device is mounted in a test socket with maintained transverse airflow greater than 500 lfm. The device will meet specifications after thermal equilibrium has been reached under these conditions.

All parameters measured at f_{OUT} unless noted otherwise.

NOTE 1: Jitter performance using XTAL inputs.

NOTE 2: This parameter is defined in accordance with JEDEC Standard 65.

NOTE 3: Defined as skew between outputs at the same supply voltage and with equal load conditions. Measured at the differential cross points.

NOTE 4: Refer to the Phase Noise Plot.

NOTE 5: Measurement taken from differential waveform.

NOTE 6: t_{STABLE} is the time the differential clock must maintain a minimum $\pm 150\text{mV}$ differential voltage after rising/falling edges before it is allowed to drop back into the $V_{rb} \pm 100\text{mV}$ range. See Parameter Measurement Information Section.

NOTE 7: Measurement taken from single-ended waveform.

NOTE 8: Defined as the maximum instantaneous voltage including overshoot. See Parameter Measurement Information Section.

NOTE 9: Defined as the minimum instantaneous voltage including undershoot. See Parameter Measurement Information Section.

NOTE 10: Measured at the crossing point where the instantaneous voltage value of the rising edge of Q[Ax:Ex] equals the falling edge of nQ[Ax:Ex].

NOTE 11: Refers to the total variation from the lowest crossing point to the highest, regardless of which edge is crossing. Refers to all crossing points for this measurement.

NOTE 12: Defined as the total variation of all crossing voltages of rising Q[Ax:Ex] and falling nQ[Ax:Ex]. This is the maximum allowed variance in V_{CROSS} for any particular system.

NOTE 13: Measured from -150mV to $+150\text{mV}$ on the differential waveform (derived from Q[Ax:Ex] minus nQ[Ax:Ex]). The signal must be monotonic through the measurement region for rise and fall time. The 300mV measurement window is centered on the differential zero crossing.

Typical Phase Noise at 100MHz (HCSL Output)

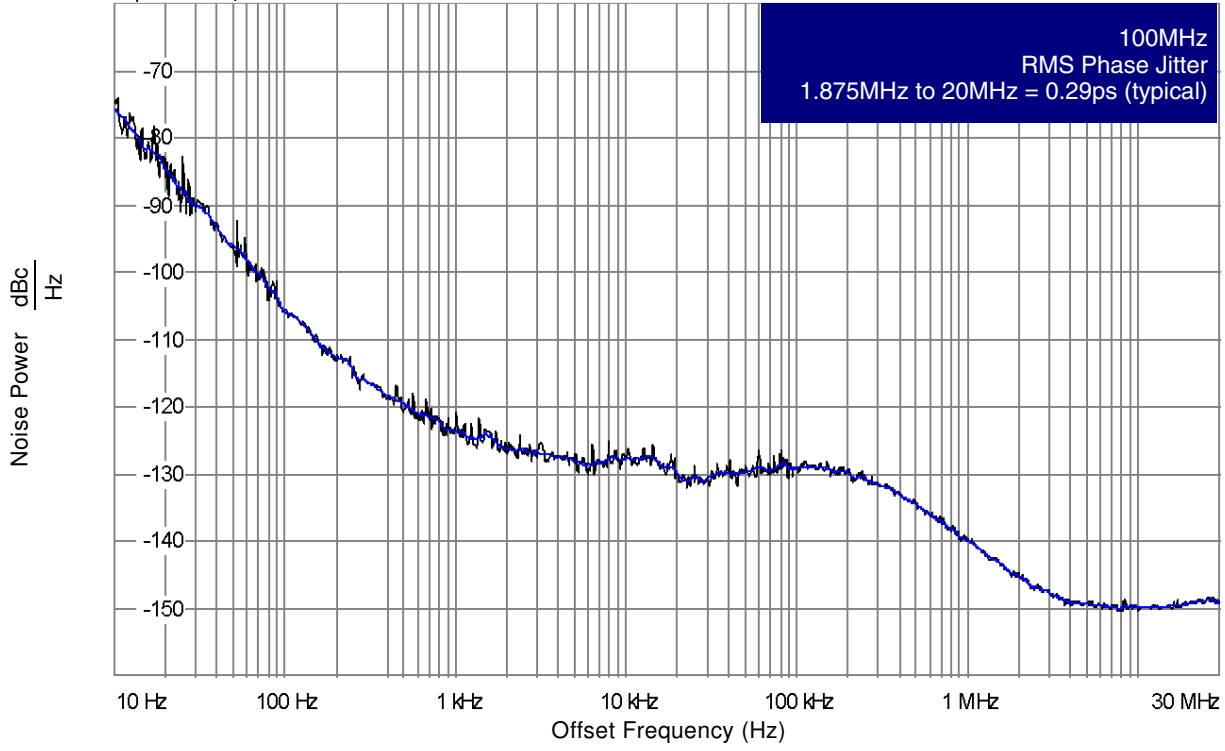

Typical Phase Noise at 156.25MHz (LVPECL Output)

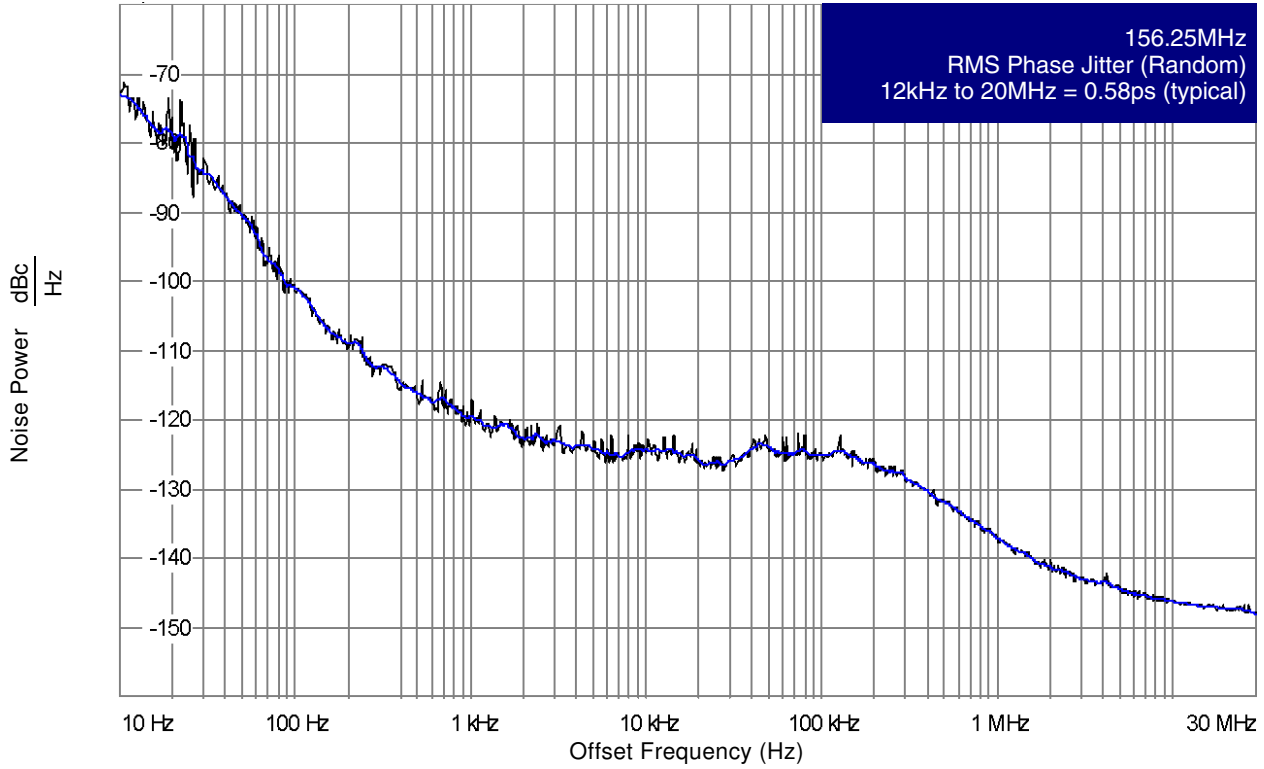

Parameter Measurement Information

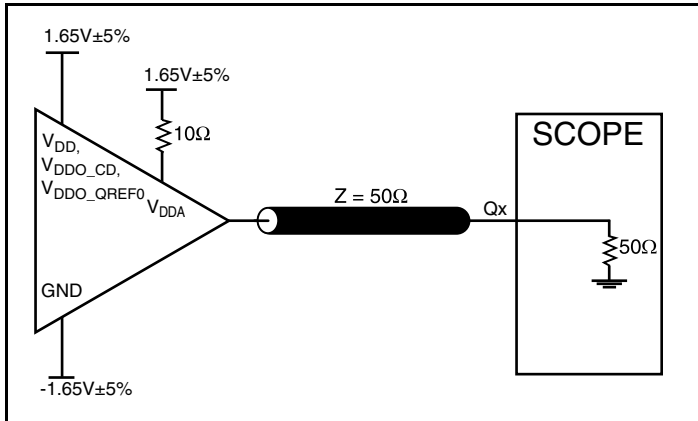

3.3V Core/3.3V LVCMOS Output Load AC Test Circuit

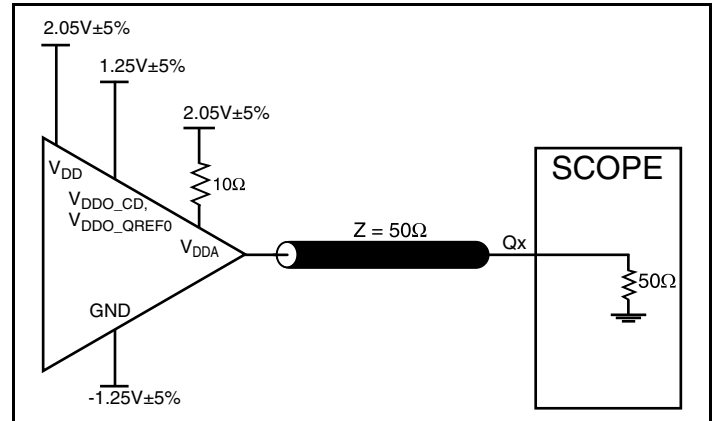

3.3V Core/2.5V LVCMOS Output Load AC Test Circuit

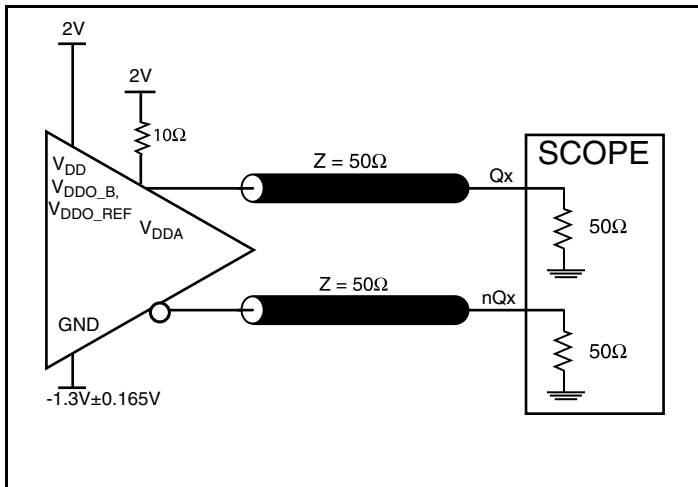

3.3V Core/3.3V LVPECL Output Load AC Test Circuit

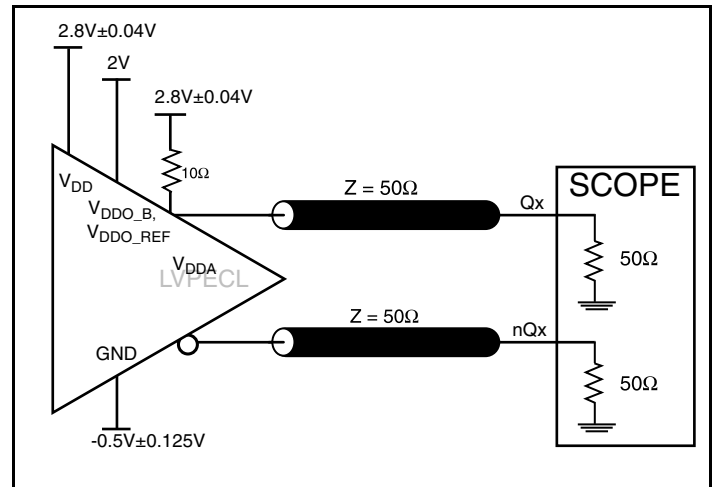

3.3V Core/2.5V LVPECL Output Load AC Test Circuit

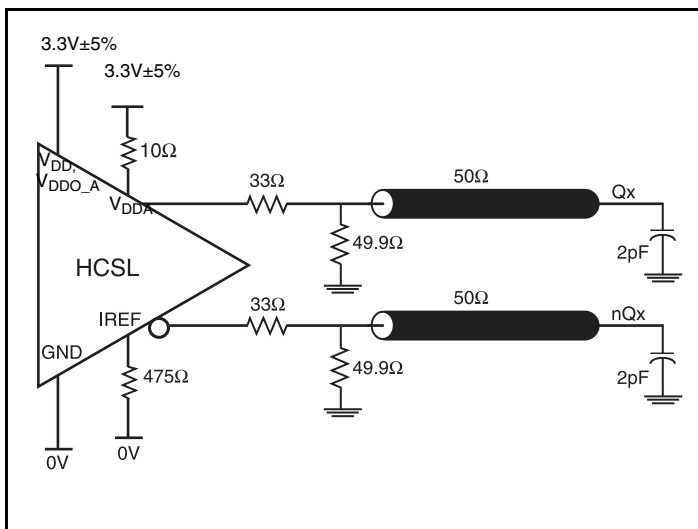

3.3V Core/3.3V HCSL Output Load AC Test Circuit

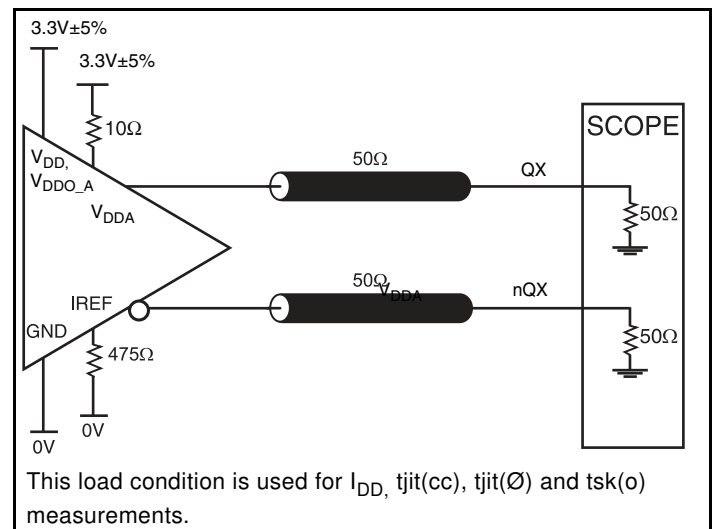

3.3V Core/3.3V HCSL Output Load AC Test Circuit

Parameter Measurement Information, continued

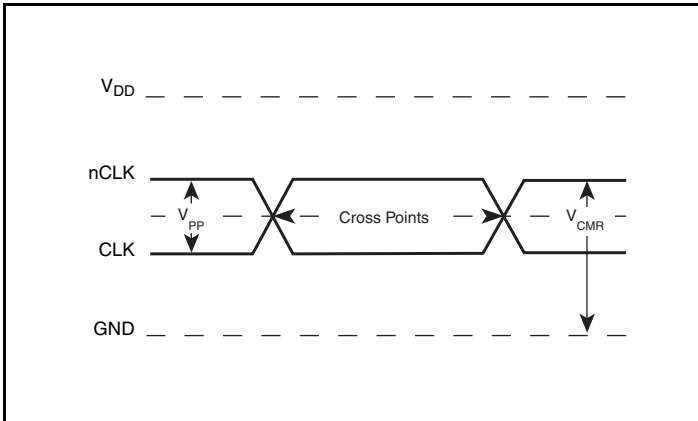

Differential Input Level

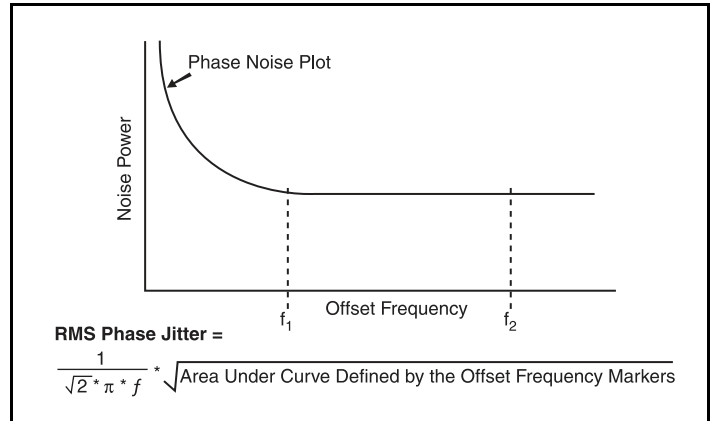

RMS Phase Jitter

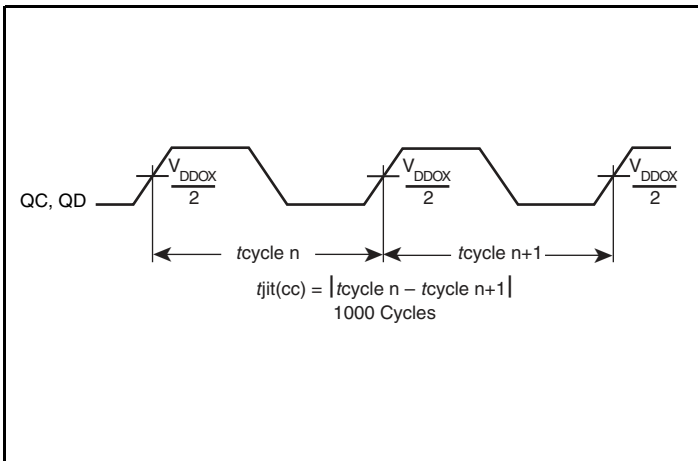

LVCMOS Cycle-to-Cycle Jitter

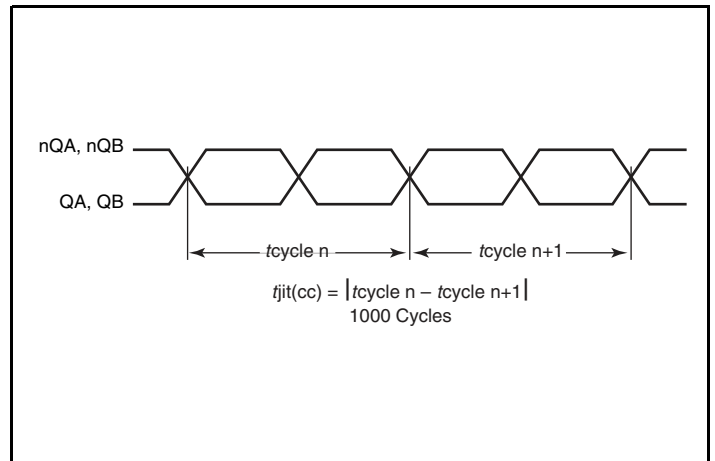

Differential Cycle-to-Cycle Jitter

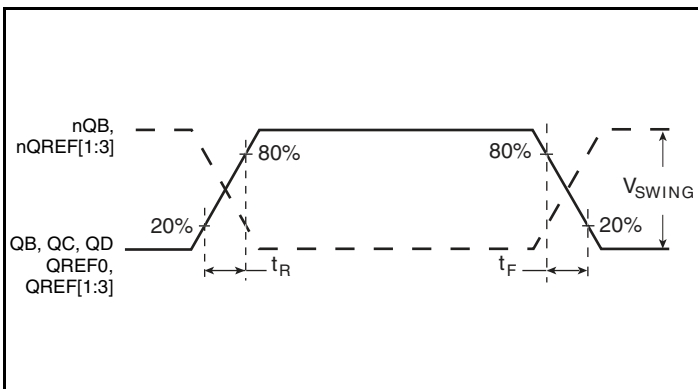

LVCMOS/LVPECL Output Rise/Fall Time

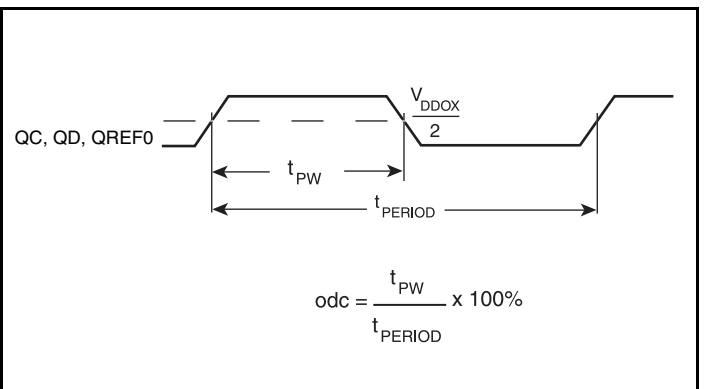

LVCMOS Output Duty Cycle/Pulse Width

Parameter Measurement Information, continued

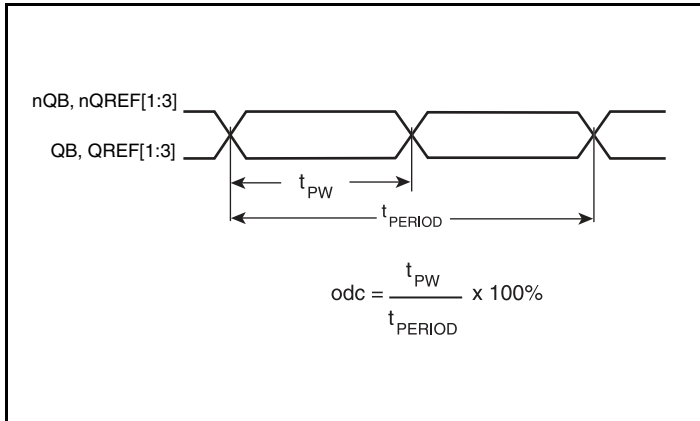

LVPECL Output Duty Cycle/Pulse Width

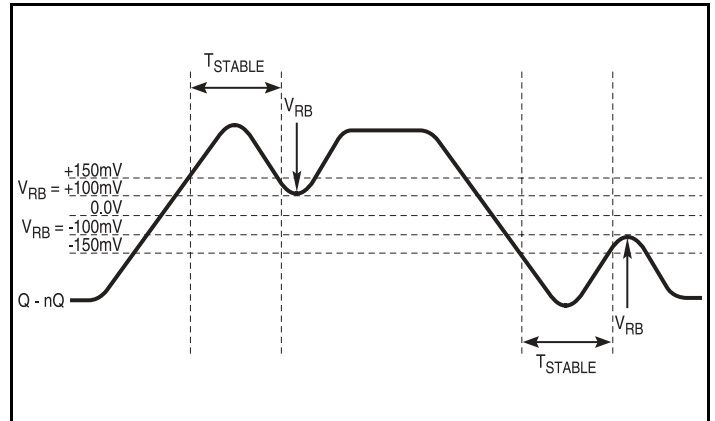

Differential Measurement Points for Ringback

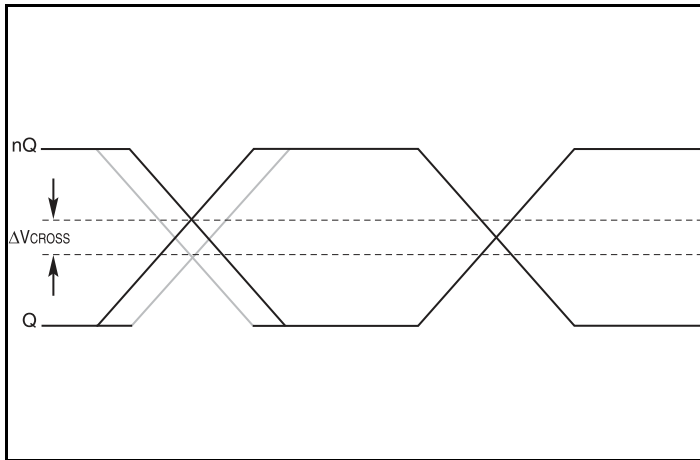

Single-ended Measurement Points for Delta Cross Point

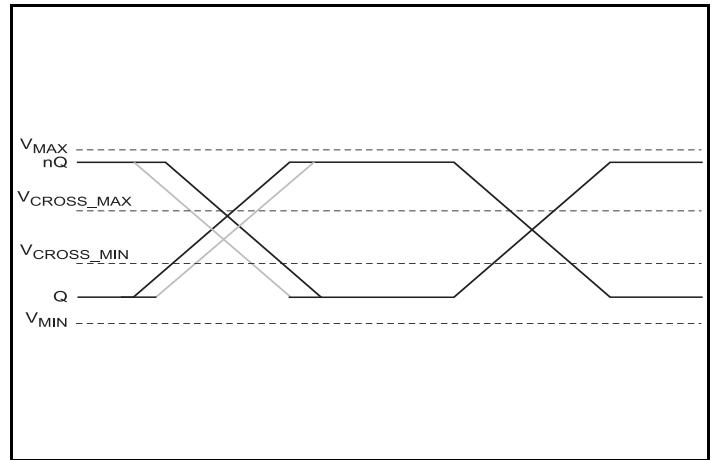

Single-ended Measurement Points for Absolute Cross Point/Swing

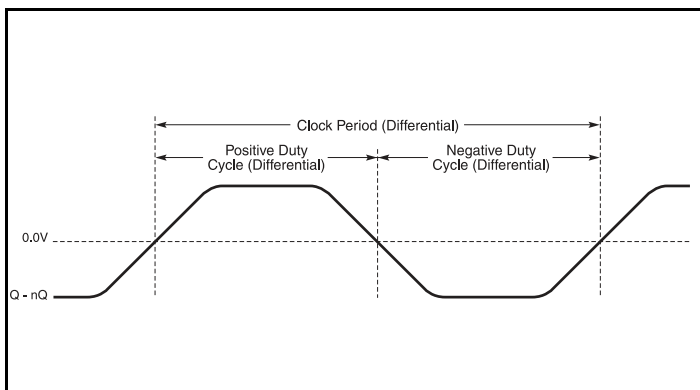

Differential Measurement Points for Duty Cycle/Period

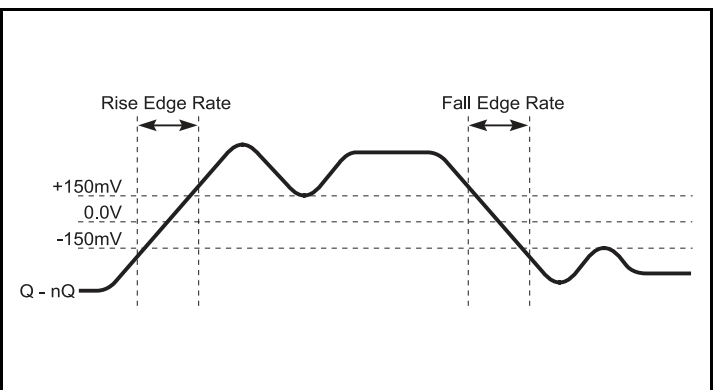

Differential Measurement Points for Rise/Fall Time Edge Rate

Applications Information

Recommendations for Unused Input and Output Pins

Inputs:

LVC MOS Control Pins

All control pins have internal pullups or pulldowns; additional resistance is not required but can be added for additional protection. A 1k Ω resistor can be used.

Crystal Inputs

For applications not requiring the use of the crystal oscillator input, both XTAL_IN and XTAL_OUT can be left floating. Though not required, but for additional protection, a 1k Ω resistor can be tied from XTAL_IN to ground.

CLK/nCLK Inputs

For applications not requiring the use of the differential input, both CLK and nCLK can be left floating. Though not required, but for additional protection, a 1k Ω resistor can be tied from CLK to ground.

Outputs:

LVPECL Outputs

The unused LVPECL output can be left floating. We recommend that there is no trace attached. Both sides of the differential output pair should either be left floating or terminated.

LVC MOS Outputs

All unused LVC MOS output can be left floating. There should be no trace attached.

Differential Outputs

All unused differential outputs can be left floating. We recommend that there is no trace attached. Both sides of the differential output pair should either be left floating or terminated.

PCI Express Application Note

PCI Express jitter analysis methodology models the system response to reference clock jitter. The block diagram below shows the most frequently used *Common Clock Architecture* in which a copy of the reference clock is provided to both ends of the PCI Express Link.

In the jitter analysis, the transmit (Tx) and receive (Rx) serdes PLLs are modeled as well as the phase interpolator in the receiver. These transfer functions are called H1, H2, and H3 respectively. The overall system transfer function at the receiver is: $H_t(s) = H_3(s) \times [H_1(s) - H_2(s)]$

The jitter spectrum seen by the receiver is the result of applying this system transfer function to the clock spectrum X(s) and is:

$$Y(s) = X(s) \times H_3(s) \times [H_1(s) - H_2(s)]$$

In order to generate time domain jitter numbers, an inverse Fourier Transform is performed on $X(s) \times H_3(s) \times [H_1(s) - H_2(s)]$.

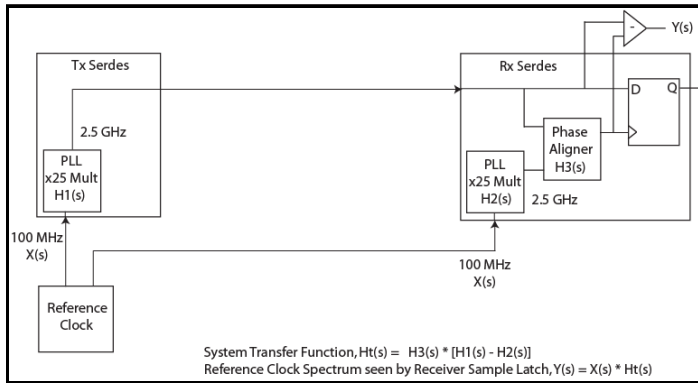

PCI Express Common Clock Architecture

For **PCI Express Gen 1**, one transfer function is defined and the evaluation is performed over the entire spectrum: DC to Nyquist (e.g for a 100MHz reference clock: 0Hz – 50MHz) and the jitter result is reported in peak-peak.

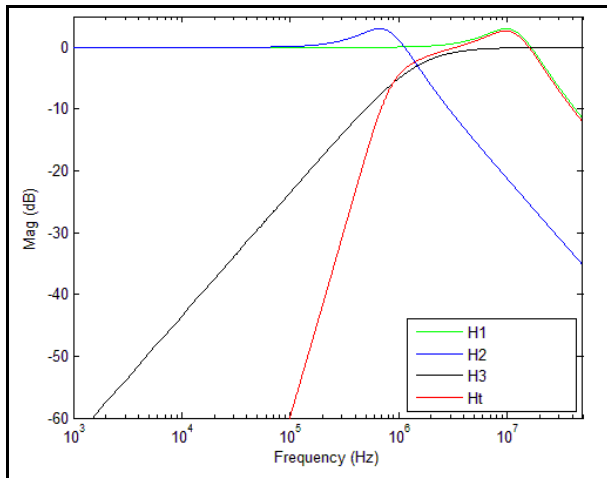

PCI Express Gen 1 Magnitude of Transfer Function

For **PCI Express Gen 2**, two transfer functions are defined with 2 evaluation ranges and the final jitter number is reported in rms. The two evaluation ranges for PCI Express Gen 2 are 10kHz – 1.5MHz (Low Band) and 1.5MHz – Nyquist (High Band). The plots show the individual transfer functions as well as the overall transfer function Ht.

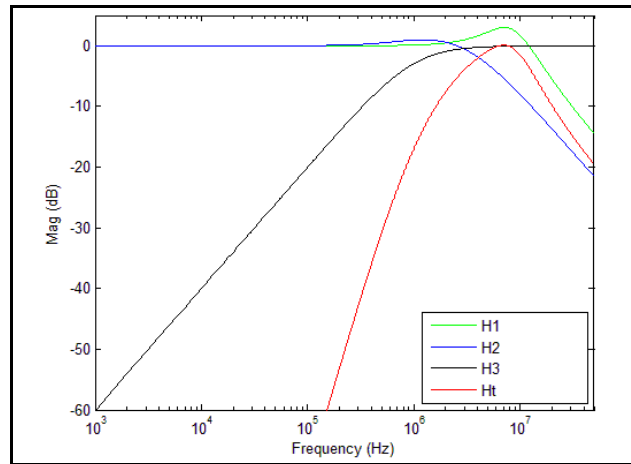

PCI Express Gen 2A Magnitude of Transfer Function

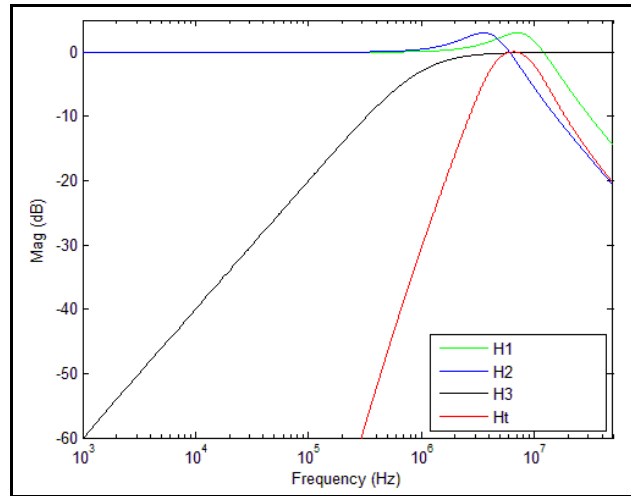

PCI Express Gen 2B Magnitude of Transfer Function

For **PCI Express Gen 3**, one transfer function is defined and the evaluation is performed over the entire spectrum. The transfer function parameters are different from Gen 1 and the jitter result is reported in RMS.

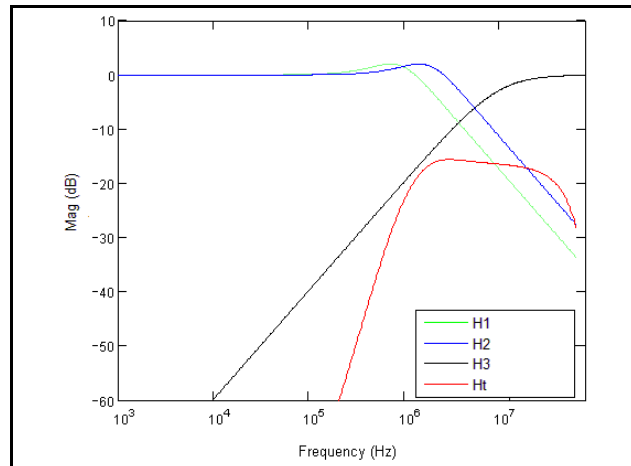

PCI Express Gen 3 Magnitude of Transfer Function

For a more thorough overview of PCI Express jitter analysis methodology, please refer to IDT Application Note *PCI Express Reference Clock Requirements*.

Wiring the Differential Input to Accept Single-Ended Levels

Figure 1 shows how a differential input can be wired to accept single ended levels. The reference voltage $V_1 = V_{DD}/2$ is generated by the bias resistors R1 and R2. The bypass capacitor (C1) is used to help filter noise on the DC bias. This bias circuit should be located as close to the input pin as possible. The ratio of R1 and R2 might need to be adjusted to position the V_1 in the center of the input voltage swing. For example, if the input clock swing is 2.5V and $V_{DD} = 3.3V$, R1 and R2 value should be adjusted to set V_1 at 1.25V. The values below are for when both the single ended swing and V_{DD} are at the same voltage. This configuration requires that the sum of the output impedance of the driver (R_o) and the series resistance (R_s) equals the transmission line impedance. In addition, matched termination at the input will attenuate the signal in half. This can be done in one of two ways. First, R3 and R4 in parallel should equal the transmission

line impedance. For most 50Ω applications, R3 and R4 can be 100Ω . The values of the resistors can be increased to reduce the loading for slower and weaker LVCMOS driver. When using single-ended signaling, the noise rejection benefits of differential signaling are reduced. Even though the differential input can handle full rail LVCMOS signaling, it is recommended that the amplitude be reduced. The datasheet specifies a lower differential amplitude, however this only applies to differential signals. For single-ended applications, the swing can be larger, however V_{IL} cannot be less than $-0.3V$ and V_{IH} cannot be more than $V_{DD} + 0.3V$. Though some of the recommended components might not be used, the pads should be placed in the layout. They can be utilized for debugging purposes. The datasheet specifications are characterized and guaranteed by using a differential signal.

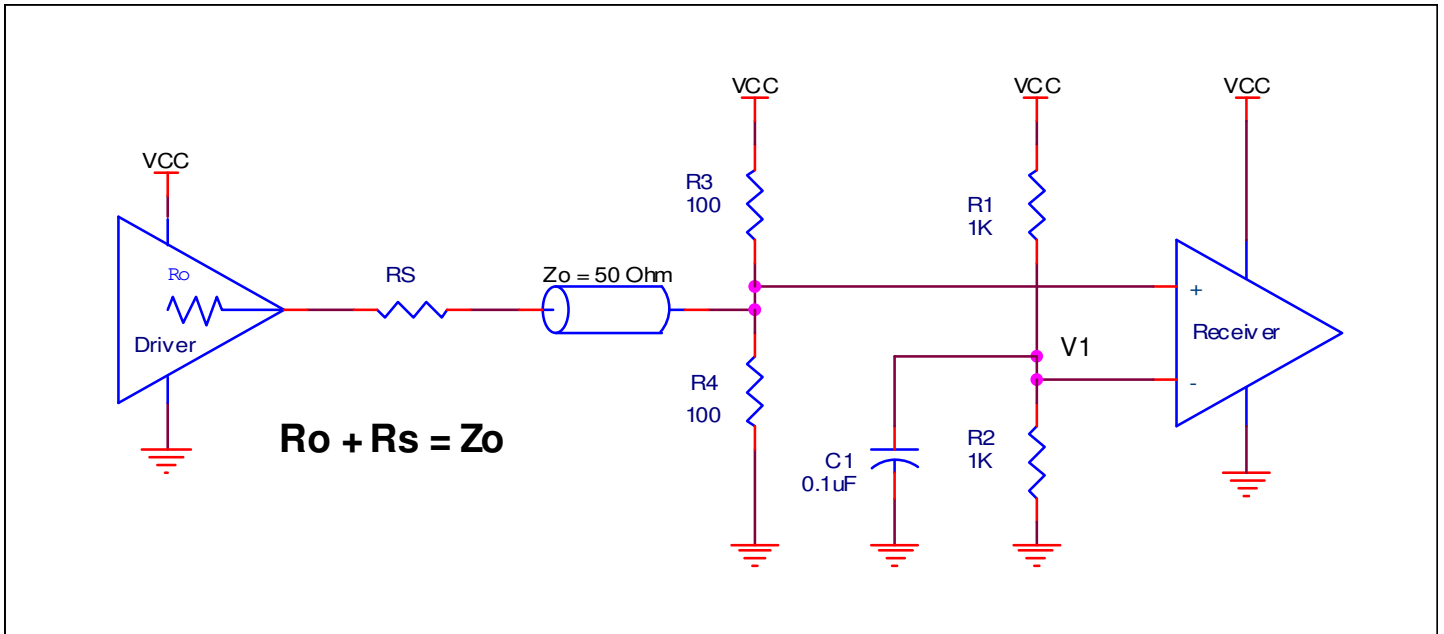

Figure 1. Recommended Schematic for Wiring a Differential Input to Accept Single-ended Levels

Differential Clock Input Interface

The CLK /nCLK accepts LVDS, LVPECL, LVHSTL, HCSL and other differential signals. Both signals must meet the V_{PP} and V_{CMR} input requirements. *Figures 2A to 2E* show interface examples for the CLK/nCLK input driven by the most common driver types. The input interfaces suggested here are examples only. Please consult with the

vendor of the driver component to confirm the driver termination requirements. For example, in Figure 2A, the input termination applies for IDT open emitter LVHSTL drivers. If you are using an LVHSTL driver from another vendor, use their termination recommendation.

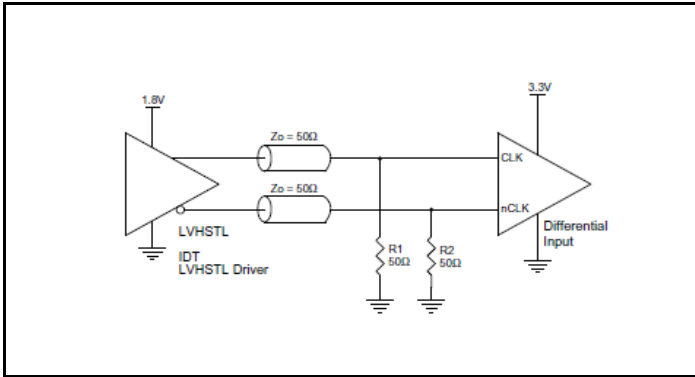

Figure 2A. CLK/nCLK Input Driven by an IDT Open Emitter LVHSTL Driver

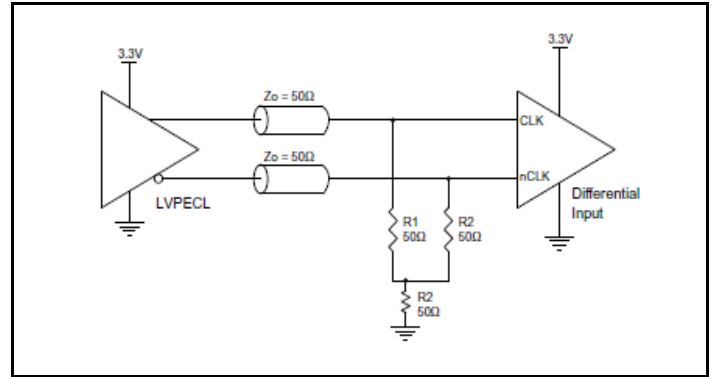

Figure 2B. CLK/nCLK Input Driven by a 3.3V LVPECL Driver

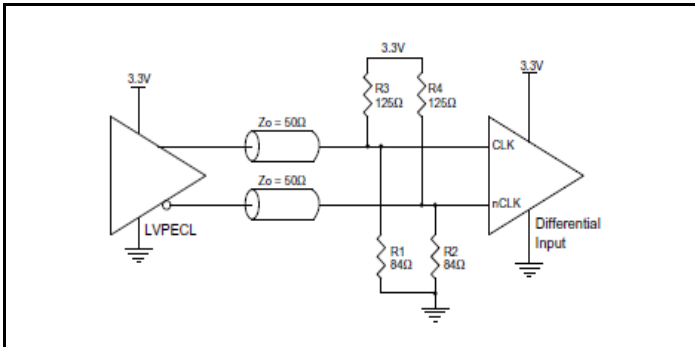

Figure 2C. CLK/nCLK Input Driven by a 3.3V LVPECL Driver

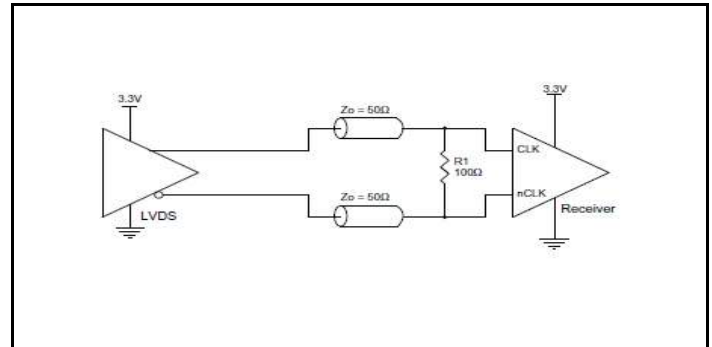

Figure 2D. CLK/nCLK Input Driven by a 3.3V LVDS Driver

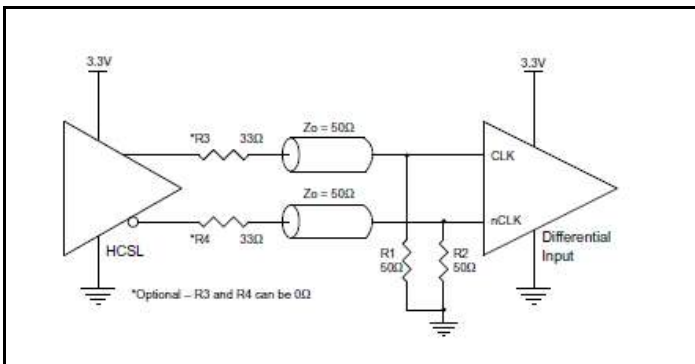

Figure 2E. CLK/nCLK Input Driven by a 3.3V HCSL Driver

Overdriving the XTAL Interface

The XTAL_IN input can be overdriven by an LVCMOS driver or by one side of a differential driver through an AC coupling capacitor. The XTAL_OUT pin can be left floating. The amplitude of the input signal should be between 500mV and 1.8V and the slew rate should not be less than 0.2V/nS. For 3.3V LVCMOS inputs, the amplitude must be reduced from full swing to at least half the swing in order to prevent signal interference with the power rail and to reduce internal noise. *Figure 3A* shows an example of the interface diagram for a high speed 3.3V LVCMOS driver. This configuration requires that the sum of the output impedance of the driver (R_o) and the series resistance (R_s) equals the transmission line impedance. In addition, matched termination at the crystal input will attenuate the signal in half. This

can be done in one of two ways. First, R_1 and R_2 in parallel should equal the transmission line impedance. For most 50Ω applications, R_1 and R_2 can be 100Ω. This can also be accomplished by removing R_1 and changing R_2 to 50Ω. The values of the resistors can be increased to reduce the loading for a slower and weaker LVCMOS driver. *Figure 3B* shows an example of the interface diagram for an LVPECL driver. This is a standard LVPECL termination with one side of the driver feeding the XTAL_IN input. It is recommended that all components in the schematics be placed in the layout. Though some components might not be used, they can be utilized for debugging purposes. The datasheet specifications are characterized and guaranteed by using a quartz crystal as the input.

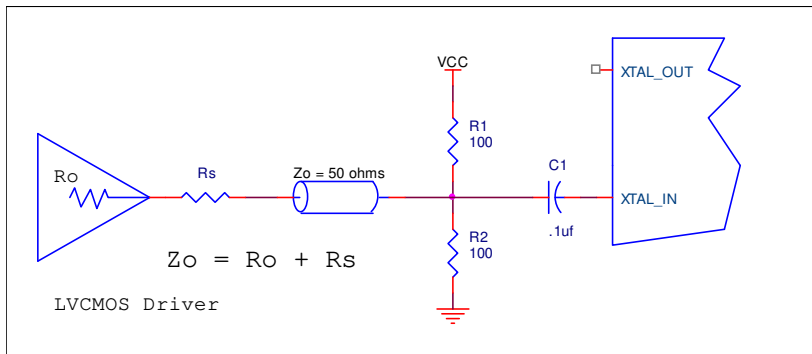

Figure 3A. General Diagram for LVCMOS Driver to XTAL Input Interface

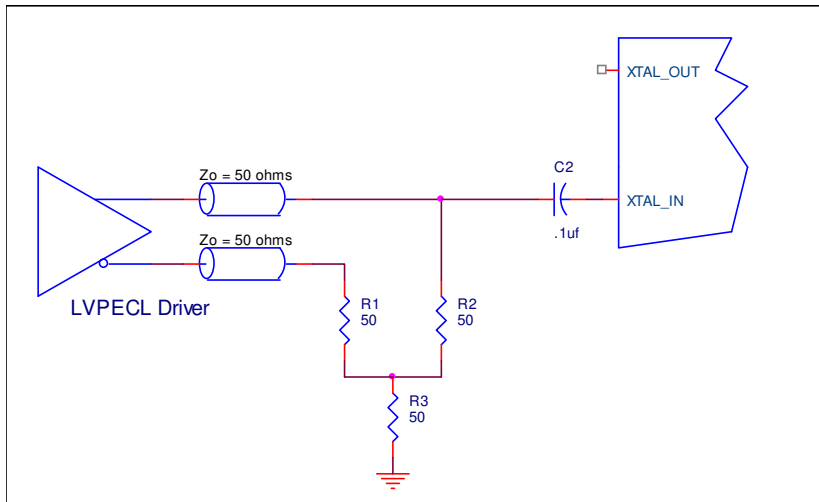

Figure 3B. General Diagram for LVPECL Driver to XTAL Input Interface

Termination for 3.3V LVPECL Outputs

The clock layout topology shown below is a typical termination for LVPECL outputs. The two different layouts mentioned are recommended only as guidelines.

The differential outputs are low impedance follower outputs that generate ECL/LVPECL compatible outputs. Therefore, terminating resistors (DC current path to ground) or current sources must be used for functionality. These outputs are designed to drive 50Ω

transmission lines. Matched impedance techniques should be used to maximize operating frequency and minimize signal distortion.

Figures 4A and 4B show two different layouts which are recommended only as guidelines. Other suitable clock layouts may exist and it would be recommended that the board designers simulate to guarantee compatibility across all printed circuit and clock component process variations.

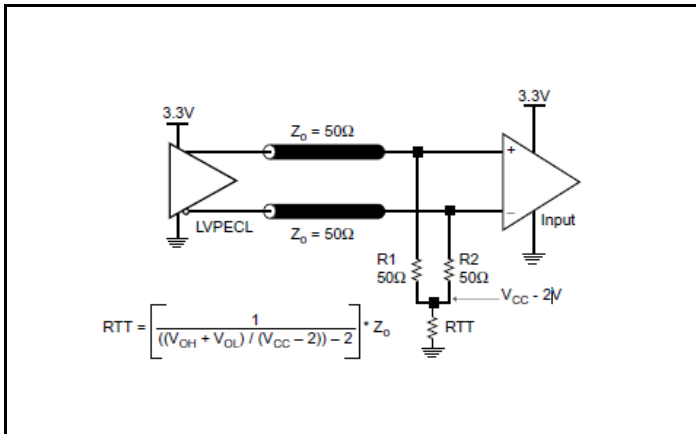

Figure 4A. 3.3V LVPECL Output Termination

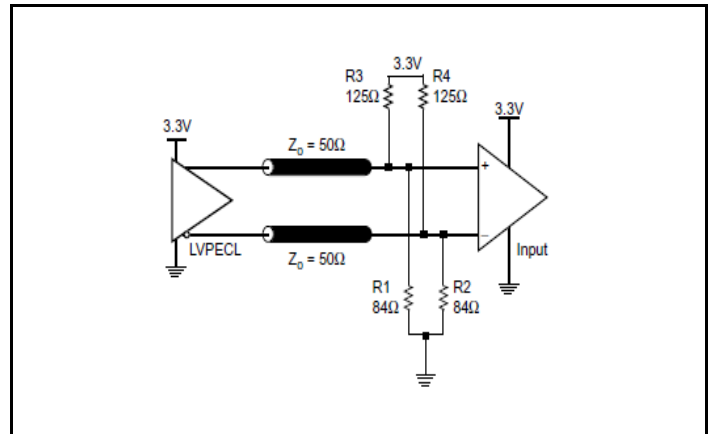

Figure 4B. 3.3V LVPECL Output Termination

Termination for 2.5V LVPECL Outputs

Figure 5A and Figure 5B show examples of termination for 2.5V LVPECL driver. These terminations are equivalent to terminating 50Ω to $V_{DD} - 2V$. For $V_{DDO} = 2.5V$, the $V_{DDO} - 2V$ is very close to ground

level. The R3 in Figure 5B can be eliminated and the termination is shown in Figure 5C.

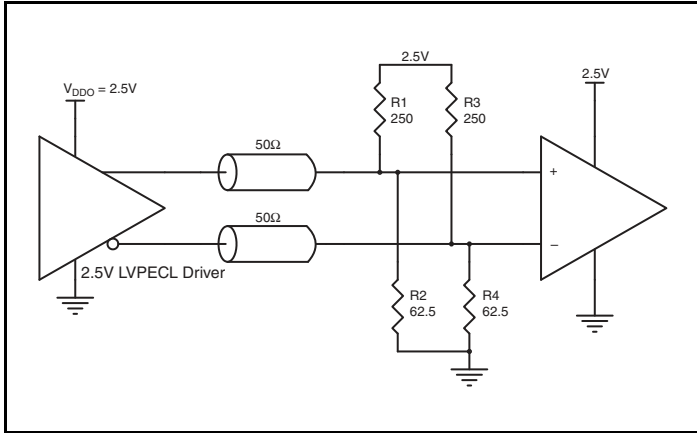

Figure 5A. 2.5V LVPECL Driver Termination Example

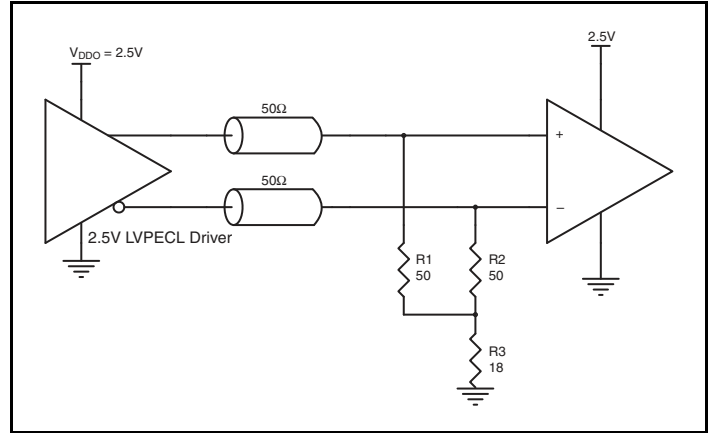

Figure 5B. 2.5V LVPECL Driver Termination Example

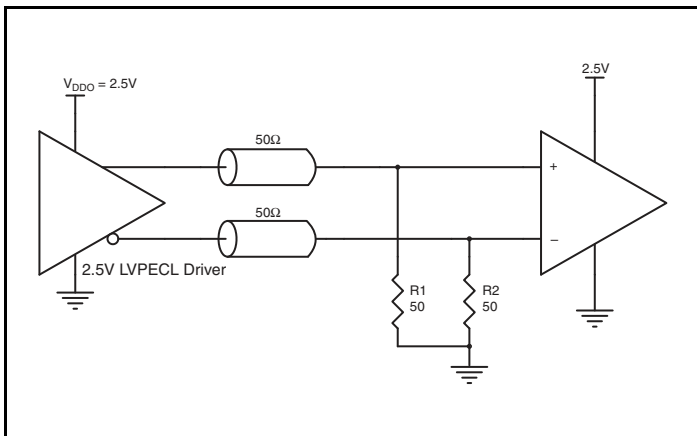

Figure 5C. 2.5V LVPECL Driver Termination Example

Recommended Termination

Figure 6A is the recommended source termination for applications where the driver and receiver will be on a separate PCBs. This termination is the standard for PCI Express™ and HCSL output types. All traces should be 50Ω impedance single-ended or 100Ω differential.

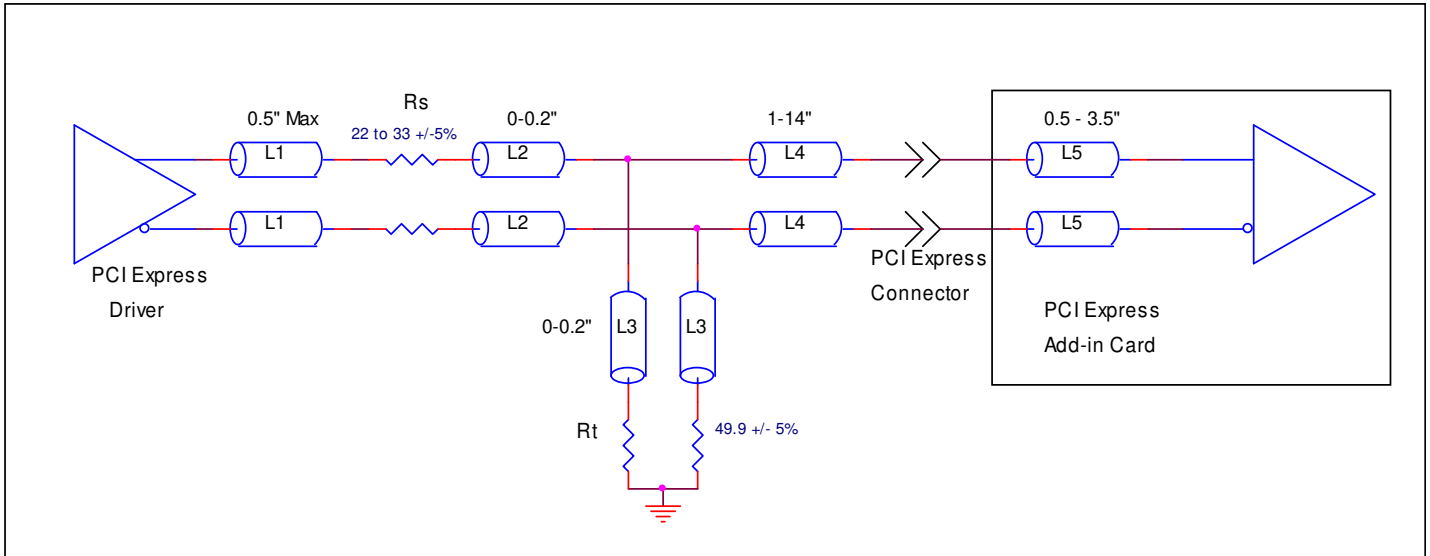

Figure 6A. Recommended Source Termination (where the driver and receiver will be on separate PCBs)

Figure 6B is the recommended termination for applications where a point-to-point connection can be used. A point-to-point connection contains both the driver and the receiver on the same PCB. With a matched termination at the receiver, transmission-line reflections will be minimized. In addition, a series resistor (R_s) at the driver offers flexibility and can help dampen unwanted reflections. The optional resistor can range from 0Ω to 33Ω. All traces should be 50Ω impedance single-ended or 100Ω differential.

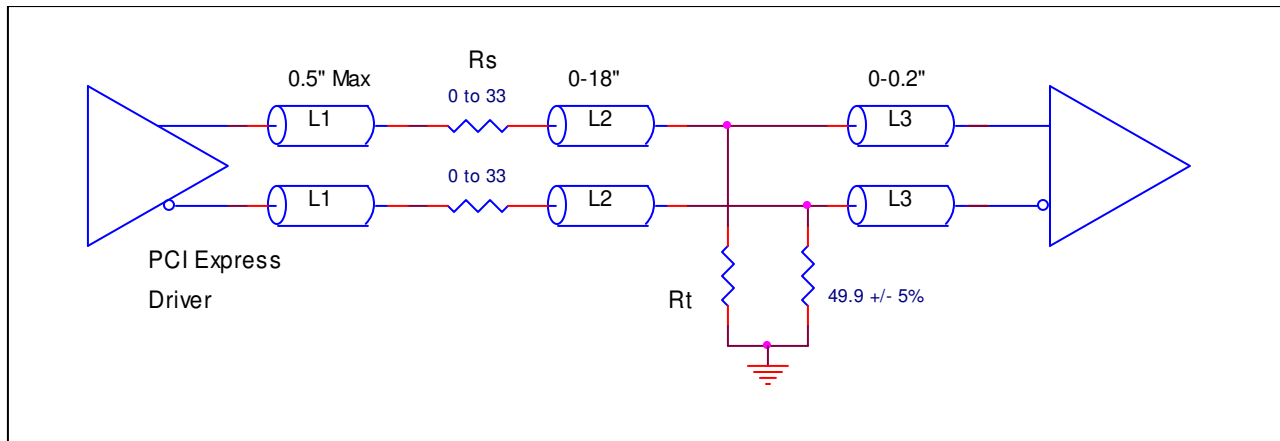

Figure 6B. Recommended Termination (where a point-to-point connection can be used)

Schematic Layout

Figure 7 shows an example of 8413S08 application schematic. In this example, the device is operated $V_{DD} = V_{DDO_A} = V_{DDO_REF} = V_{DDO_B} = V_{DDO_CD} = V_{DDO_REF0} = 3.3V$. The 18pF parallel resonant 25MHz crystal is used. The load capacitance $C1 = 18pF$ and $C2 = 18pF$ are recommended for frequency accuracy. Depending on the parasitic of the printed circuit board layout, these values might require a slight adjustment to optimize the frequency accuracy. Crystals with other load capacitance specifications can be used. For this device, the crystal load capacitors are required for proper operation. As with any high speed analog circuitry, the power supply pins are vulnerable to random noise. To achieve optimum jitter performance, power supply isolation is required. The 8413S08 provides separate power supplies to isolate any high switching noise from coupling into the internal PLL. In order to achieve the best possible filtering, it is recommended that the placement of the filter

components be on the device side of the PCB as close to the power pins as possible. If space is limited, the 0.1uf capacitor in each power pin filter should be placed on the device side. The other components can be on the opposite side of the PCB.

Power supply filter recommendations are a general guideline to be used for reducing external noise from coupling into the devices. The filter performance is designed for wide range of noise frequency. This low-pass filter starts to attenuate noise at approximately 10 kHz. If a specific frequency noise component with high amplitude interference is known, such as switching power supplies frequencies, it is recommended that component values be adjusted and if required, additional filtering be added. Additionally, good general design practice for power plane voltage stability suggests adding bulk capacitances in the general area of all devices

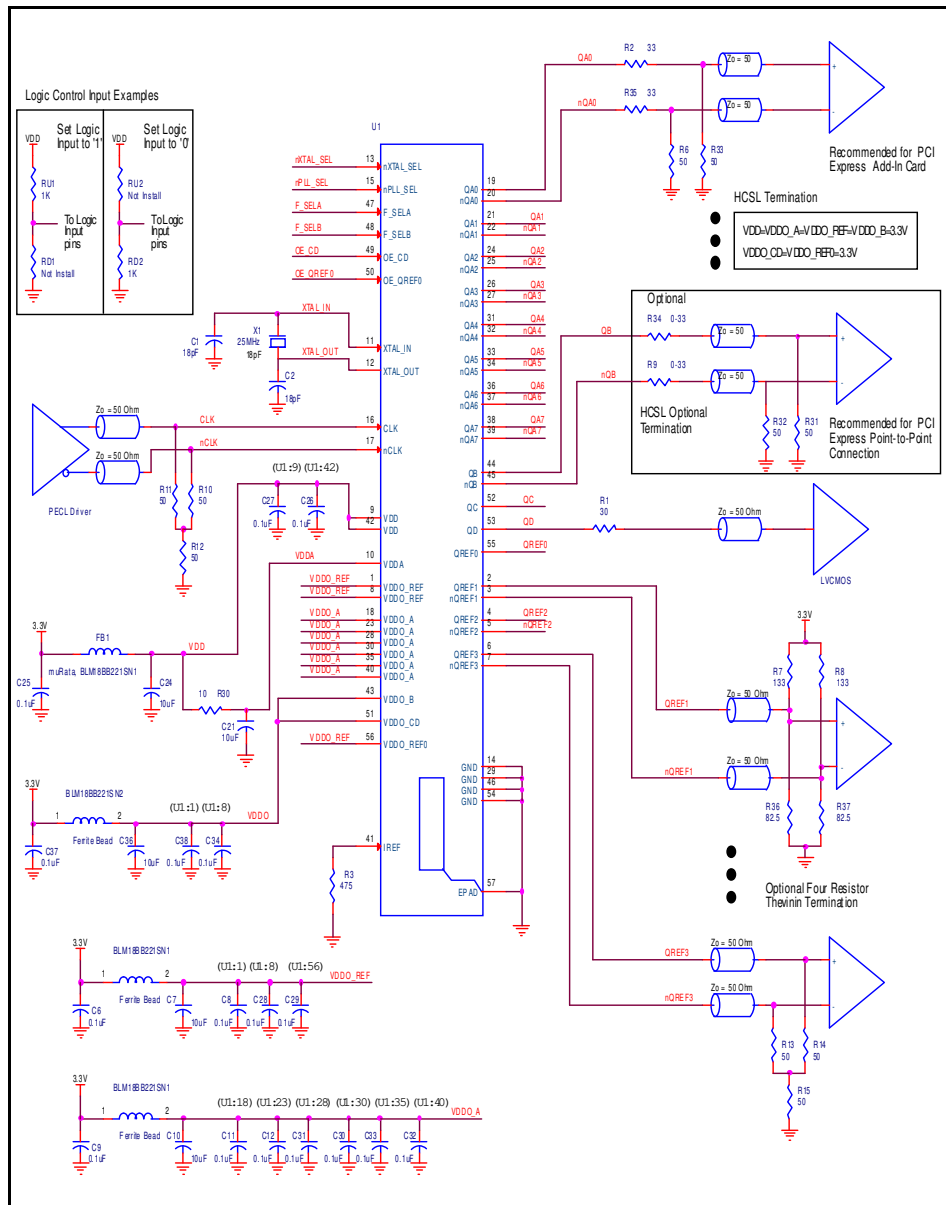

Figure 7. 8413S08 Application Schematic

The schematic example focuses on functional connections and is not configuration specific.

Refer to the pin description and functional tables in the datasheet to ensure the logic control inputs are properly set.

VFQFN EPAD Thermal Release Path

In order to maximize both the removal of heat from the package and the electrical performance, a land pattern must be incorporated on the Printed Circuit Board (PCB) within the footprint of the package corresponding to the exposed metal pad or exposed heat slug on the package, as shown in *Figure 8*. The solderable area on the PCB, as defined by the solder mask, should be at least the same size/shape as the exposed pad/slug area on the package to maximize the thermal/electrical performance. Sufficient clearance should be designed on the PCB between the outer edges of the land pattern and the inner edges of pad pattern for the leads to avoid any shorts.

While the land pattern on the PCB provides a means of heat transfer and electrical grounding from the package to the board through a solder joint, thermal vias are necessary to effectively conduct from the surface of the PCB to the ground plane(s). The land pattern must be connected to ground through these vias. The vias act as “heat pipes”. The number of vias (i.e. “heat pipes”) are application specific and dependent upon the package power dissipation as well as electrical conductivity requirements. Thus, thermal and electrical analysis and/or testing are recommended to determine the minimum number needed. Maximum thermal and electrical performance is

achieved when an array of vias is incorporated in the land pattern. It is recommended to use as many vias connected to ground as possible. It is also recommended that the via diameter should be 12 to 13mils (0.30 to 0.33mm) with 1oz copper via barrel plating. This is desirable to avoid any solder wicking inside the via during the soldering process which may result in voids in solder between the exposed pad/slug and the thermal land. Precautions should be taken to eliminate any solder voids between the exposed heat slug and the land pattern. Note: These recommendations are to be used as a guideline only. For further information, please refer to the Application Note on the Surface Mount Assembly of Amkor’s Thermally/Electrically Enhance Leadframe Base Package, Amkor Technology.

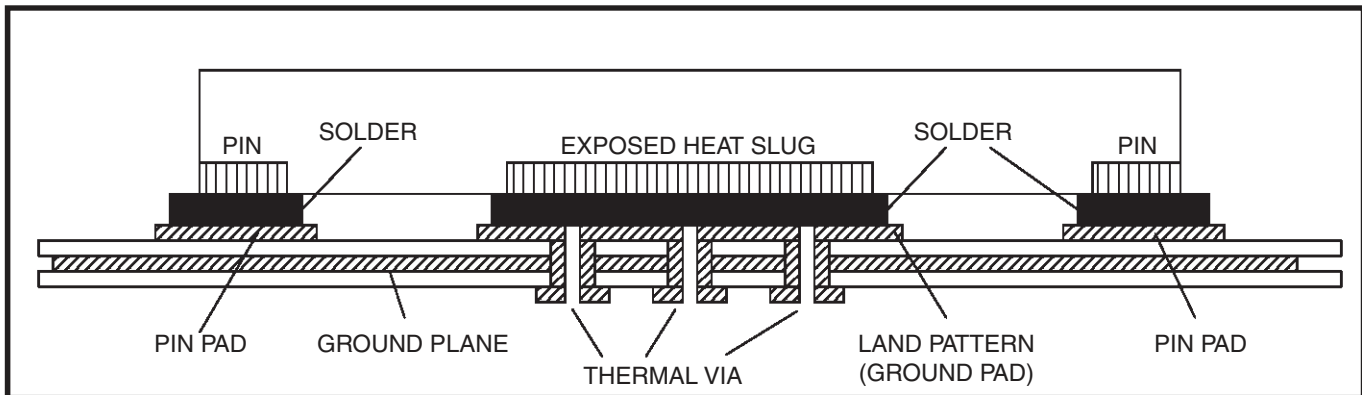

Figure 8. P.C. Assembly for Exposed Pad Thermal Release Path – Side View (drawing not to scale)

Power Considerations

This section provides information on power dissipation and junction temperature for the 8413S08. Equations and example calculations are also provided.

1. Power Dissipation

The total power dissipation for the 8413S08 is the sum of the core power plus the analog power plus the power dissipated in the load(s). The following is the power dissipation for $V_{DD} = 3.3V + 5\% = 3.465V$, which gives worst case results.

Core

- Power(core) = $V_{DD_MAX} * (I_{DD} + I_{DDA} + I_{DDOX}) = 3.465V * (84mA + 16mA + 66mA) = \mathbf{575.19mW}$

LVPECL Output

LVPECL driver power dissipation is 30mW/Loaded output pair, total LVPECL output dissipation:

- Power(LVPECL) = $30mW * 4 = 120mW$

HSCL Output

HSCL driver power dissipation is 46.8mW/Loaded output pair, total HSCL output dissipation:

- Power(HSCL) = $46.8mW * 8 = 374.4mW$

LVC MOS Output

- Output Impedance R_{OUT} Power Dissipation due to Loading 50Ω to $V_{DD}/2$
Output Current $I_{OUT} = V_{DD_MAX} / [2 * (50\Omega + R_{OUT})] = 3.465V / [2 * (50\Omega + 20\Omega)] = \mathbf{24.75mA}$
- Power Dissipation on the R_{OUT} per LVC MOS output
Power (R_{OUT}) = $R_{OUT} * (I_{OUT})^2 = 20\Omega * (24.75mA)^2 = \mathbf{12.3mW}$ per output
- Total Power Dissipation on the R_{OUT}
Total Power (R_{OUT}) = $12.3mW * 3 = 36.9mW$

Dynamic Power Dissipation at 50MHz

$$\text{Power (50MHz)} = C_{PD} * \text{Frequency} * (V_{DD})^2 = 4pF * 50MHz * (3.465V)^2 = \mathbf{2.4mW}$$
 per output
Total Power (50MHz) = $2.4mW * 3 = 7.2mW$

Total Power Dissipation

- Total Power**
= Power (core) + Power (LVPECL) + Power(HSCL) + Total Power (R_{OUT}) + Total Power (50MHz)
= $575.19mW + 120mW + 374.4mW + 36.9mW + 7.2mW$
= **1113.7mW**

2. Junction Temperature.

Junction temperature, T_j , is the temperature at the junction of the bond wire and bond pad directly affects the reliability of the device. The maximum recommended junction temperature is 125°C. Limiting the internal transistor junction temperature, T_j , to 125°C ensures that the bond wire and bond pad temperature remains below 125°C.

The equation for T_j is as follows: $T_j = \theta_{JA} * Pd_{total} + T_A$

T_j = Junction Temperature

θ_{JA} = Junction-to-Ambient Thermal Resistance

Pd_{total} = Total Device Power Dissipation (example calculation is in section 1 above)

T_A = Ambient Temperature

In order to calculate junction temperature, the appropriate junction-to-ambient thermal resistance θ_{JA} must be used. Assuming no air flow and a multi-layer board, the appropriate value is 31.4°C/W per Table 7 below.

Therefore, T_j for an ambient temperature of 85°C with all outputs switching is:

$$85^\circ\text{C} + 1.113\text{W} * 31.4^\circ\text{C/W} = 119.9^\circ\text{C}. \text{ This is below the limit of } 125^\circ\text{C}.$$

This calculation is only an example. T_j will obviously vary depending on the number of loaded outputs, supply voltage, air flow and the type of board (multi-layer).

Table 7. Thermal Resistance θ_{JA} for 56 Lead VFQFN, Forced Convection

θ_{JA} by Velocity			
Meters per Second	0	1	2.5
Multi-Layer PCB, JEDEC Standard Test Boards	31.4°C/W	27.5°C/W	24.6°C/W

3A. Calculations and Equations.

The purpose of this section is to calculate power dissipation on the LVPECL output pair.

LVPECL output driver circuit and termination are shown in *Figure 10*.

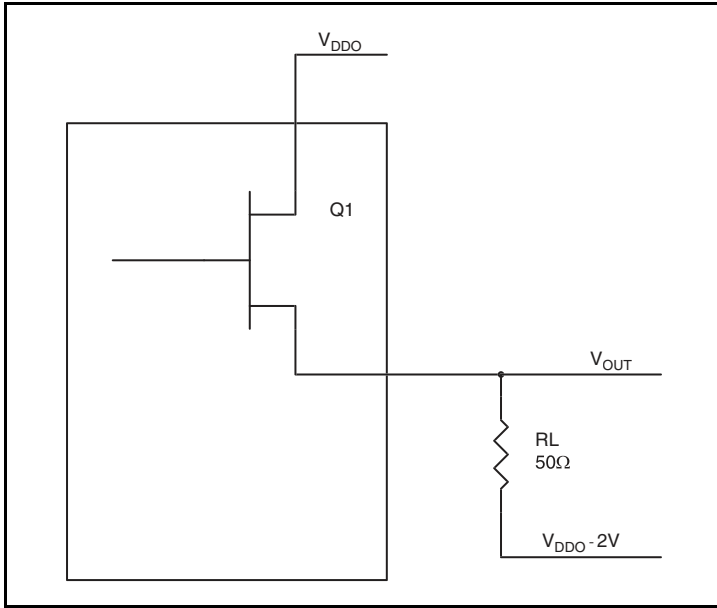

Figure 9. LVPECL Driver Circuit and Termination

To calculate worst case power dissipation into the load, use the following equations which assume a 50Ω load, and a termination voltage of V_{DDO} - 2V.

- For logic high, V_{OUT} = V_{OH_MAX} = V_{DDO_MAX} - 0.9V
(V_{DDO_MAX} - V_{OH_MAX}) = 0.9V
- For logic low, V_{OUT} = V_{OL_MAX} = V_{DDO_MAX} - 1.7V
(V_{DDO_MAX} - V_{OL_MAX}) = 1.7V

Pd_H is power dissipation when the output drives high.

Pd_L is the power dissipation when the output drives low.

$$Pd_H = [(V_{OH_MAX} - (V_{DDO_MAX} - 2V))/R_L] * (V_{DDO_MAX} - V_{OH_MAX}) = [(2V - (V_{DDO_MAX} - V_{OH_MAX}))/R_L] * (V_{DDO_MAX} - V_{OH_MAX}) = [(2V - 0.9V)/50\Omega] * 0.9V = \mathbf{19.8mW}$$

$$Pd_L = [(V_{OL_MAX} - (V_{DDO_MAX} - 2V))/R_L] * (V_{DDO_MAX} - V_{OL_MAX}) = [(2V - (V_{DDO_MAX} - V_{OL_MAX}))/R_L] * (V_{DDO_MAX} - V_{OL_MAX}) = [(2V - 1.7V)/50\Omega] * 1.7V = \mathbf{10.2mW}$$

Total Power Dissipation per output pair = Pd_H + Pd_L = **30mW**

3B. Calculations and Equations.

The purpose of this section is to calculate power dissipation on the IC per HCSL output pair.

HCSL output driver circuit and termination are shown in *Figure 11*.

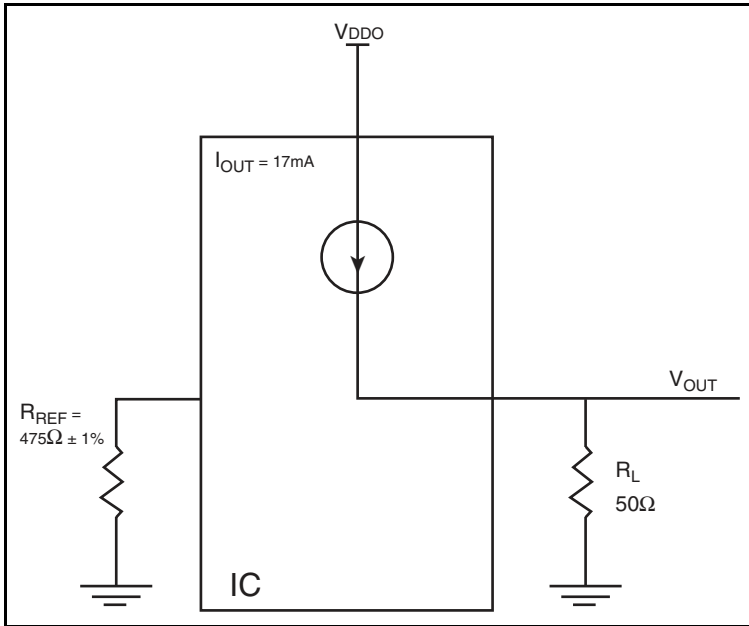

Figure 10. HCSL Driver Circuit and Termination

HCSL is a current steering output which sources a maximum of 17mA of current per output. To calculate worst case on-chip power dissipation, use the following equations which assume a 50Ω load to ground.

The highest power dissipation occurs when V_{DDO_MAX} .

$$\begin{aligned}
 \text{Power} &= (V_{DDO_MAX} - V_{OUT}) * I_{OUT}, \\
 \text{since } V_{OUT} &= I_{OUT} * R_L \\
 &= (V_{DDO_MAX} - I_{OUT} * R_L) * I_{OUT} \\
 &= (3.6V - 17mA * 50\Omega) * 17mA
 \end{aligned}$$

Total Power Dissipation per output pair = **46.8mW**

Reliability Information

Table 8. θ_{JA} vs. Air Flow Table for a 56 Lead VFQFN

θ_{JA} vs. Air Flow			
Meters per Second	0	1	2.5
Multi-Layer PCB, JEDEC Standard Test Boards	31.4°C/W	27.5°C/W	24.6°C/W

Transistor Count

The transistor count for 8413S08 is: 9994

Package Outline and Package Dimensions

Package Outline - K Suffix for 56 Lead VFQFN

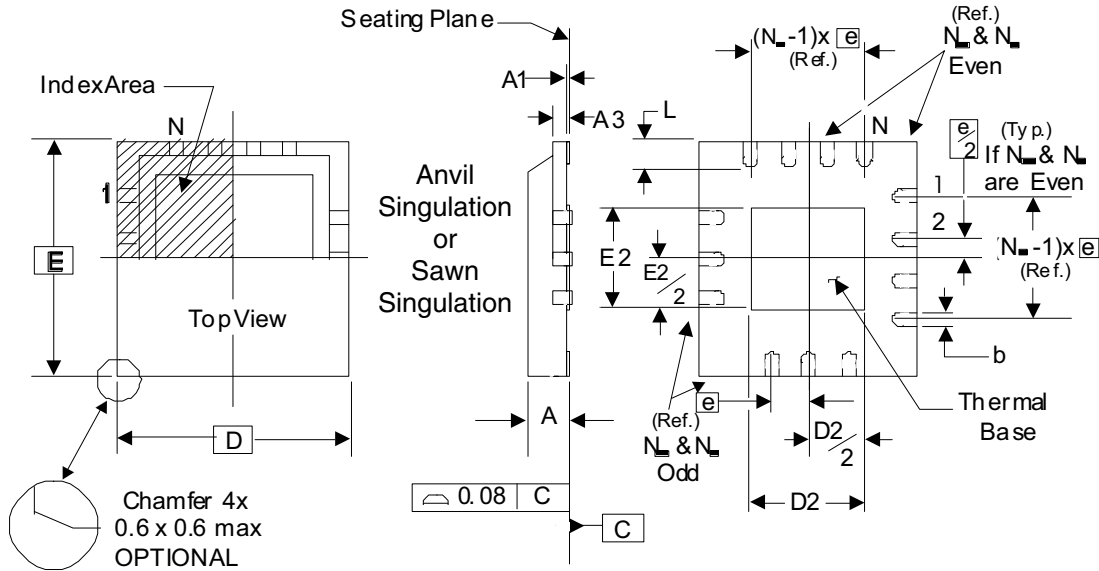

Bottom View w/Type A ID

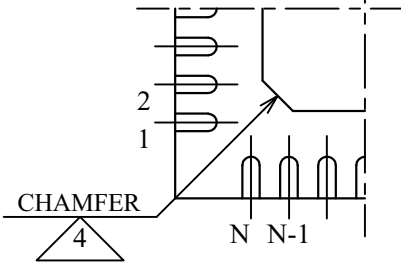

Bottom View w/Type C ID

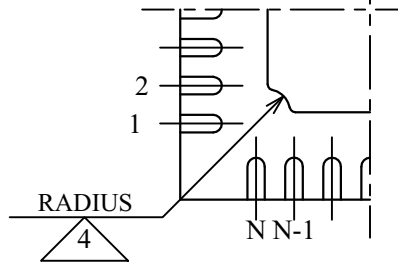

There are 2 methods of indicating pin 1 corner at the back of the VFQFN package:

1. Type A: Chamfer on the paddle (near pin 1)
2. Type C: Mouse bite on the paddle (near pin 1)

Table 8. Package Dimensions

JEDEC Variation: VLLD-2/-5 All Dimensions in Millimeters		
Symbol	Minimum	Maximum
N	56	
A	0.80	1.00
A1	0	0.05
A3	0.25 Ref.	
b	0.18	0.30
N_D & N_E	14	
D & E	8.00 Basic	
D2	4.35	4.65
E2	5.05	5.35
e	0.50 Basic	
L	0.30	0.50

Reference Document: JEDEC Publication 95, MO-220

NOTE: The following package mechanical drawing is a generic drawing that applies to any pin count VFQFN package. This drawing is not intended to convey the actual pin count or pin layout of this device. The pin count and pinout are shown on the front page. The package dimensions are in Table 8 below.

Ordering Information

Table 9. Ordering Information

Part/Order Number	Marking	Package	Shipping Packaging	Temperature
8413S08BKILF	ICS8413S08BIL	"Lead-Free" 56 VFQFN	Tray	-40°C to 85°C
8413S08BKILFT	ICS8413S08BIL	"Lead-Free" 56 VFQFN	Tape & Reel	-40°C to 85°C

Revision History

Revision Date	Description of Change
10/3/16	Updated header and footer. Removed ICS from part numbers where needed. Ordering Information - Deleted quantity from tape and reel. Removed note from below table.

IMPORTANT NOTICE AND DISCLAIMER

RENESAS ELECTRONICS CORPORATION AND ITS SUBSIDIARIES (“RENESAS”) PROVIDES TECHNICAL SPECIFICATIONS AND RELIABILITY DATA (INCLUDING DATASHEETS), DESIGN RESOURCES (INCLUDING REFERENCE DESIGNS), APPLICATION OR OTHER DESIGN ADVICE, WEB TOOLS, SAFETY INFORMATION, AND OTHER RESOURCES “AS IS” AND WITH ALL FAULTS, AND DISCLAIMS ALL WARRANTIES, EXPRESS OR IMPLIED, INCLUDING, WITHOUT LIMITATION, ANY IMPLIED WARRANTIES OF MERCHANTABILITY, FITNESS FOR A PARTICULAR PURPOSE, OR NON-INFRINGEMENT OF THIRD PARTY INTELLECTUAL PROPERTY RIGHTS.

These resources are intended for developers skilled in the art designing with Renesas products. You are solely responsible for (1) selecting the appropriate products for your application, (2) designing, validating, and testing your application, and (3) ensuring your application meets applicable standards, and any other safety, security, or other requirements. These resources are subject to change without notice. Renesas grants you permission to use these resources only for development of an application that uses Renesas products. Other reproduction or use of these resources is strictly prohibited. No license is granted to any other Renesas intellectual property or to any third party intellectual property. Renesas disclaims responsibility for, and you will fully indemnify Renesas and its representatives against, any claims, damages, costs, losses, or liabilities arising out of your use of these resources. Renesas' products are provided only subject to Renesas' Terms and Conditions of Sale or other applicable terms agreed to in writing. No use of any Renesas resources expands or otherwise alters any applicable warranties or warranty disclaimers for these products.

(Disclaimer Rev.1.0 Mar 2020)

Corporate Headquarters

TOYOSU FORESIA, 3-2-24 Toyosu,
Koto-ku, Tokyo 135-0061, Japan
www.renesas.com

Contact Information

For further information on a product, technology, the most up-to-date version of a document, or your nearest sales office, please visit:
www.renesas.com/contact/

Trademarks

Renesas and the Renesas logo are trademarks of Renesas Electronics Corporation. All trademarks and registered trademarks are the property of their respective owners.