

UNCONTROLLED DOCUMENT

PART NUMBER  
SLX-LX3054UWC

REV.  
A

REV.	E.C.N. NUMBER AND REVISION COMMENTS	DATE
A	E.C.N. #11148.	5.8.07

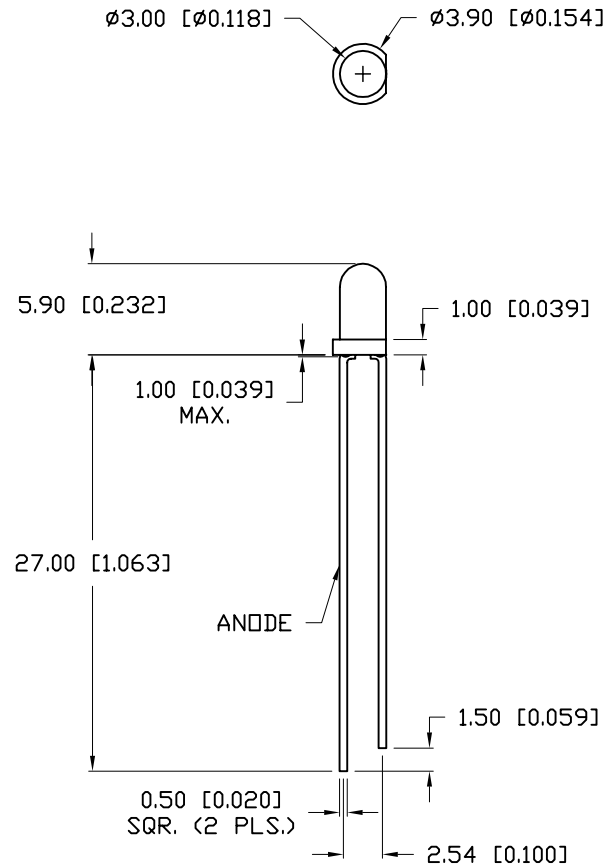

NOTES:

1. LED LEADS SILVER.

ELECTRO-OPTICAL CHARACTERISTICS  $T_A=25^{\circ}\text{C}$

PARAMETER	SYMBOL	MIN	TYP	MAX	UNITS	TEST COND
PEAK WAVELENGTH			-		nm	
FORWARD VOLTAGE	$V_f$		3.5	4.0	V	$I_f=20\text{mA}$
REVERSE VOLTAGE	$V_r$	5			V	$I_r=10\mu\text{A}$
AXIAL INTENSITY(*1)	$I_v$		3300		mcd	$I_f=20\text{mA}$
CHROMATICITY	X		0.30			$I_f=10\text{mA}$
COORDINATES(*2)	Y		0.30			
VIEWING ANGLE			30		2x theta	
EMITTED COLOR:			WHITE			
EPOXY LENS FINISH:			WATER CLEAR			

\*1. AXIAL INTENSITY TESTING CONDITION: 550nm WAVELENGTH.  
\*2. THE ICI STANDARD COLORIMETRIC SYSTEM.

LIMITS OF SAFE OPERATION AT 25°C

PARAMETER	SYMBOL	MAX	UNITS
PULSE FORWARD CURRENT	$I_p$	100*	mA
STEADY CURRENT	$I_F$	30	mA
POWER DISSIPATION	$P_D$	120	mW
OPERATING TEMP.	$T_{OPR}$	-30 TO +80	°C
STORAGE TEMP.	$T_{STG}$	-40 TO +100	°C
SOLDERING TEMP.		+260	°C
		2.0mm FROM BODY	3 SEC. MAX

\*DUTY 1/10 PULSE WIDTH 10ms

CAUTION: STATIC SENSITIVE DEVICE  
FOLLOW PROPER E.S.D. HANDLING PROCEDURES  
WHEN WORKING WITH THIS PART.



UNCONTROLLED DOCUMENT

\*UNLESS OTHERWISE SPECIFIED TOLERANCES PER DECIMAL PRECISION ARE: X=±1 (±0.039), X.X=±0.5 (±0.020), X.XX=±0.25 (±0.010), X.XXX=±0.127 (±0.005). LEAD SIZE=±0.05 (±0.002), LEAD LENGTH=±0.75 (±0.030). MIN.= +DECIMAL PRECISION MAX.= +0.00 -DECIMAL PRECISION

REV. A	PART NUMBER SLX-LX3054UWC
-----------	------------------------------

T-3mm (T-1) WHITE LED,  
WATER CLEAR LENS.

**CONFIDENTIAL INFORMATION**  
THE INFORMATION CONTAINED IN THIS DOCUMENT IS THE PROPERTY OF LUMEX INC. EXCEPT AS SPECIFICALLY AUTHORIZED IN WRITING BY LUMEX INC., THE HOLDER OF THIS DOCUMENT SHALL KEEP ALL INFORMATION CONTAINED HEREIN CONFIDENTIAL AND SHALL PROTECT SAME IN WHOLE OR IN PART FROM DISCLOSURE AND DISSEMINATION TO ALL THIRD PARTIES.

**RELIABILITY NOTE**  
OUR MANY YEARS OF EXPERIENCE DATA ACCUMULATION INDICATE THAT SOLDER HEAT IS A MAJOR CAUSE OF EARLY AND FUTURE FAILURE. PLEASE PAY ATTENTION TO YOUR SOLDERING PROCESS.



290 E. HELEN ROAD  
PALATINE, IL 60067-6976  
PHONE: +1.847.359.2790  
US WEB: www.lumex.com  
TW WEB: www.lumex.com.tw

DRAWN BY: JC	CHECKED BY: BC	APPROVED BY: BC	DATE: 4.7.03
			PAGE: 1 OF 1
			SCALE: N/A