

## RT 2000

Flexible split-core Rogowski coil for the electronic measurement of AC waveform currents, with galvanic separation between the primary circuit (power) and the secondary circuit (measurement).

The patented **Perfect Loop Technology** definitely solves the problem of the Rogowski coil opening by introducing a specific magnetic device. This dramatically reduces both the error due to the position of the measured conductor within the sensor, and the error due to the proximity of external conductors.



### Electrical data

$I_{PN}$	Primary nominal rms current	2000	A
$M$	Mutual inductance transfer ratio <sup>1)</sup> ( $\pm 5\%$ )	0.064	$\mu\text{H}$
$V_{out}$	Output voltage (instantaneous) <sup>2)</sup> $V_{out} = M \times \frac{dI_p}{dt}$		V
$V_{out}$	Output voltage (sinusoidal wave) <sup>2)</sup> $V_{out} = 2 \times \pi \times M \times f \times I_{PAC}$ Example: @ 50 Hz, 500 A $V_{out} = 2 \times \pi \times 64 \times 10^{-9} \times 50 \times 2000 = 40.2\text{mV}$		V
$L_S$	Coil inductance ( $\pm 5\%$ )	190	$\mu\text{H}$
$R_S$	Coil resistance $T_A = 20\text{ }^\circ\text{C}$ typical	60	$\Omega$
	High cut-off frequency <sup>2)</sup> (+ 3 dB)	500	kHz

### Accuracy - Dynamic performance data

$\epsilon_L$	Linearity error	none	
$TCM$	Temperature coefficient of $M$	30	ppm/K
$\epsilon_p$	Positioning error <sup>3)</sup> max	0.65	%

### General data

$T_A$	Ambient operating temperature (90 % RH)	- 10 .. + 65	$^\circ\text{C}$
$T_S$	Ambient storage temperature	- 25 .. + 70	$^\circ\text{C}$
$m$	Mass	90	g
IPxx	Protection degree	IP 2X	
	Standards	Safety IEC 61010-1: 2001 2nd edition IEC 61010-2-032: 2002 IEC 61010-031: 2002 + Amd 1: 2008	

**Notes:** <sup>1)</sup> LEM provides uncalibrated coils with up to 5 % manufacturing tolerance. Calibration must be performed within the final application.

<sup>2)</sup> Open circuit condition (no load).

<sup>3)</sup> Considering a primary conductor of at least  $\varnothing 15\text{ mm}$  perpendicular to the RT loop.

### Features

- Split core type
- $\varnothing 125\text{ mm}$  sensing aperture for non-contact measurement
- 1.5 m output cable
- Insulating plastic case recognized according to UL 94-V0.

### Advantages

- Thin, lightweight and flexible
- Easy installation suitable even for the most confined spaces
- Very low positioning error.

### Applications

- **Power meters**  
Current measurement for active Power calculation.
- **Energy sub-meters**  
For energy efficiency monitoring, consumption analysis and costs allocation.
- **Power quality monitoring**
- **Condition monitoring**  
(e.g. Motor loads such as conveyers, pumps or HVAC).
- **Distributed measurement systems.**

### Application domain

- Energy Solutions.

## UL 61010-1: Ratings and assumptions of certification

File # E330077-A2-UL

### Standards

- CAN/CSA-C22.2 No. 61010-1, 2nd Edition, 2004-07 (Electrical Equipment for Measurement, Control, and laboratory Use; Part 1: General Requirements)
- UL 61010-1, 2nd Edition, 2005-07-22 (Electrical Equipment for Measurement, Control, and laboratory Use; Part 1: General Requirements)

### Ratings

Parameter	Symbol	Unit	Value
Primary involved potential		V AC/DC	300
Max surrounding air temperature	$T_A$	°C	50
Primary current	$I_P$	A	According to series primary current
Output voltage	$V_{out}$	V AC	0 to 30

### Conditions of acceptability

For use only in or with complete equipment where the acceptability of the combination is determined by Underwriters Laboratories Inc. When installed in an end-product, consideration must be given to the following:

- 1 - This component has been judged on the basis of the creepage and clearances required in the indicated Standards, which would cover the component itself if submitted for Listing: UL 61010-1 2nd Ed., CAN/CSA 22.2 No 61010-1 2nd Ed.
- 2 - The need for the following shall be considered in the end-product: Markings and documentation that comply with Clause 5.
- 3 - The following tests shall be performed in the end-product evaluation: Dielectric Strength.
- 4 - The unit is considered acceptable for use in a max ambient of: 50 °C.

### Marking

Only those products bearing the UR Mark should be considered to be Recognized and covered under UL's Follow-Up Service. Always look for the Mark on the product.

## RT 2000

### Insulation coordination

$U_b$	Rated insulation rms voltage <sup>1)</sup> with IEC 61010-1 standards following conditions: - Reinforced insulation - Over voltage category CAT III - Pollution degree PD2 - Heterogeneous field	300	V
$U_d$	Rms voltage for AC insulation test <sup>2)</sup> , 50 Hz, 1 min	3.5	kV
$\hat{U}_w$	Impulse withstand voltage 1.2/50 $\mu$ s	6.5	kV
		Min	
$d_{cp}$	Creepage distance	6	mm
$d_{cl}$	Clearance	6	mm
CTI	Comparative Tracking Index (group I) <sup>3)</sup>	600	V

**Notes:** <sup>1)</sup> Between primary conductor and ground. If insulated cable is used for the primary circuit, the voltage category could be improved according to the primary cable insulation category (please refer to the cable manufacturer's indications).  
<sup>2)</sup> Between primary (completely filling the hole) and secondary  
<sup>3)</sup> Plastic parts.

### Safety and warning notes

In order to guarantee safe operation of the transducer and to be able to make proper use of all features and functions, please read these instructions thoroughly! Safe operation can only be guaranteed if the transducer is used for the purpose it has been designed for and within the limits of the technical specifications. Ensure you get up-to-date technical information that can be found in the latest associated datasheet under [www.lem.com](http://www.lem.com).



#### Caution! Risk of danger

Ignoring the warnings can lead to serious injury and/or cause damage! The electric measuring transducer may only be installed and put into operation by qualified personnel that have received an appropriate training. The corresponding national regulations shall be observed during installation and operation of the transducer and any electrical conductor. The transducer shall be used in electric/electronic equipment with respect to applicable standards and safety requirements and in accordance with all the related systems and components manufacturers' operating instructions.



#### Caution! Risk of electrical shock

When operating the transducer, certain parts of the module may carry hazardous live voltage (e.g. primary conductor). The user shall ensure to take all measures necessary to protect against electrical shock. The transducer is a build-in device containing conducting parts that shall not be accessible after installation. A protective enclosure or additional insulation barrier may be necessary. Installation and maintenance shall be done with the main power supply disconnected except if there are no hazardous live parts in or in close proximity to the system and if the applicable national regulations are fully observed.

Safe and trouble-free operation of this transducer can only be guaranteed if transport, storage and installation are carried out correctly and operation and maintenance are carried out with care.

## Dimensions RT 2000 (in mm)

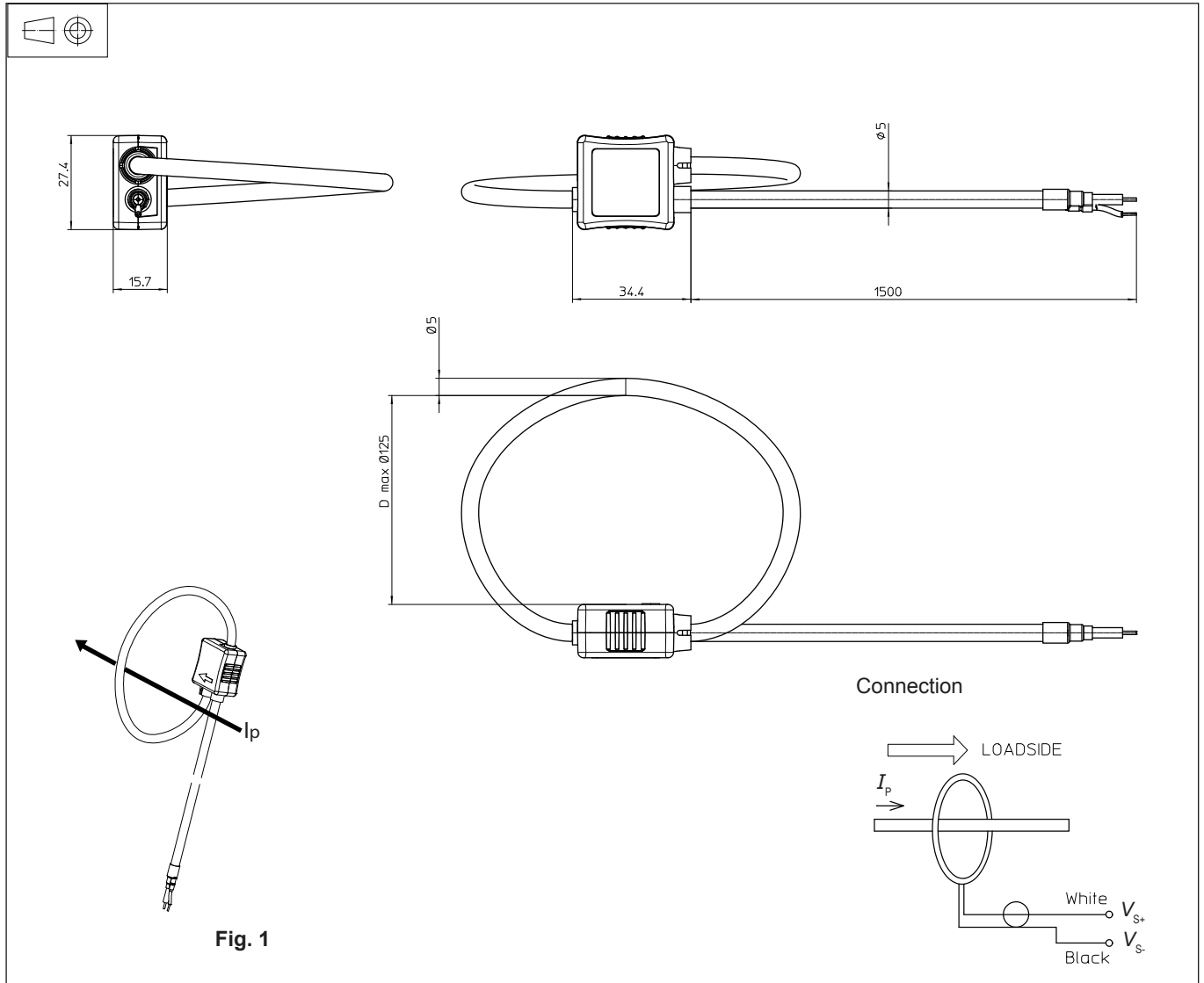

### Mechanical characteristics

- General tolerance  $\pm 1$  mm
- Output cable length 1500 mm



#### WARNING!

Do not stress the coil by applying any kind of mechanical force (ie. twisting, puncturing, excessive pressure, tight bending, etc.) which will dramatically degrade the device's accuracy.

### Remarks

- $V_{out} = V_{S+} - V_{S-}$  is positive when  $dI_p/dt$  flows in the direction of the arrow (see fig. 1)
- Due to low positioning error ( $\epsilon_p$ ), the device does not need to be physically fastened around the primary conductor. Should the device be secured, make sure no mechanical stress is applied to the coil itself.