

®

Thermofit Molded Parts

Specification Control Drawing

Limited Distribution

Part Number : CAW-9/32 thru CAW-1 5/8

Description : Ring, Convolex

NOTES

- All dimensions are in $\frac{\text{inches}}{\text{[millimeters]}}$
- Dimensions appearing in table are as follows:
a - As Supplied
- Material: Stainless steel, passivated per ASTM A313/A313M-95a.

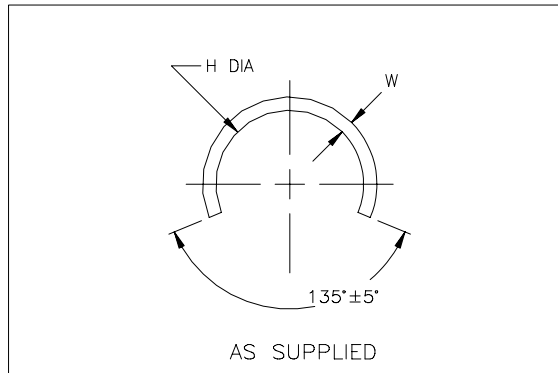

TABLE OF DIMENSIONS

PART NUMBER	H	W	PART NUMBER	H	W
	$\pm .020$	$\pm .003$		$\pm .020$	$\pm .003$
	a	a		a	a
CAW-9/32	$\frac{.306}{[7,77]}$	$\frac{.064}{[1,62]}$	CAW-3/4	$\frac{.780}{[19,81]}$	$\frac{.090}{[2,28]}$
CAW-3/8	$\frac{.396}{[10,06]}$	$\frac{.064}{[1,62]}$	CAW-7/8	$\frac{.900}{[22,86]}$	$\frac{.090}{[2,28]}$
CAW-7/16	$\frac{.470}{[11,94]}$	$\frac{.072}{[1,83]}$	CAW-1	$\frac{1.030}{[26,16]}$	$\frac{.090}{[2,28]}$
CAW-1/2	$\frac{.530}{[13,46]}$	$\frac{.072}{[1,83]}$	CAW-1 1/4	$\frac{1.286}{[32,66]}$	$\frac{.090}{[2,28]}$
CAW-5/8	$\frac{.650}{[16,51]}$	$\frac{.072}{[1,83]}$	CAW-1 5/8	$\frac{1.670}{[42,42]}$	$\frac{.090}{[2,28]}$

**If this document is printed it becomes uncontrolled.
Check for the latest revision.**

Raychem

RAYCHEM CORPORATION
300 CONSTITUTION DRIVE
MENLO PARK, CALIFORNIA 94025

Revision : E

Date : 5/12/99

Part Number : CAW-9/32 thru CAW1 5/8

Description : Ring, Convolex

CAD FILE MP99094