

XC164CS Series

The 16-bit Flash Microcontroller Family in P/PG-TQFP-100 Package



THE XC164CS SERIES are derivatives of the popular C166 microcontroller families. Based on the enhanced C166S V2 architecture it outperforms existing 16-bit solutions. Impressive DSP performance and advanced interrupt handling combined with a powerful integrated peripheral set and high performance on-chip memory make the XC164CS the instrument of choice for demanding industrial and automotive applications like synchronous DC motor control, future head lamp concepts or effective power steering solutions.

The flexible and intelligent PWM unit simplifies control of AC-, DC- or reluctance motors. A high speed, high resolution ADC handles the fast and accurate translation of complex analog environment. Networked solutions can be solved with powerful communication interfaces like the high speed TwinCAN module with autonomous gateway function.

The XC164CS series gives embedded system designers the ability to scale memory, speed and peripherals. The small P/PG-TQFP-100 package makes it fit to any industrial and automotive applications that require little board space and low cost.

Applications

- Intelligent head lamp concepts
- Electrical power steering
- Airbag
- Body control modules
- Multi phase drive control

Features

- High performance 16-bit C166S V2 CPU with 5-stage pipeline
- Single clock cycle instruction execution with 25 ns instruction time at 40 MHz CPU clock
- 25 ns multiplication (16 x 16 bit) time at 40 MHz CPU clock
- DSP support with built-in advanced MAC unit
- 16 Mbytes total linear address space for code and data
- Flexible synchronous external bus interface
- 16-priority-level Interrupt system with 8 group levels each
- Gated clock concept (function related) for reduced power consumption and improved EMCFeatures
- 6/8/12 Kbytes on-chip RAM
- 64/128/256 Kbytes on-chip program Flash (with Error Correction) or ROM

- Flexible system control and power management
- Real time clock with alarm interrupt
- 14-channel 10-bit A/D converter, conversion time down to 2.15 μ s (on versions -CS and -S)
- Two 16-channel capture/compare units with 2 independent time bases each
- Two multifunctional general purpose timer units
- Asynchronous/synchronous serial channels (USART)
- Two high speed synchronous serial channels (SPI)
- TwinCAN module, two full-CAN nodes with 32 message buffers and gateway function (on versions -CS and -D)
- CAPCOM6E module with two independent timers dedicated to PWM generation for AC and DC motor control
- On-chip real time clock
- Enhanced power saving modes with flexible power management
- Programmable watchdog timer and oscillator watchdog
- Up to 79 I/O lines with individual bit addressability
- On-chip bootstrap loader
- Supported by a large range of development tools
- On-chip debug support via JTAG interface
- Package: P/PG-TQFP-100 plastic thin quad flat package
- Temperature range: -40°C to +125°C and -40°C to + 85°C
- Supply Voltage:
 - Core Supply: 2.5 V
 - Ports: 5.0 V

www.infineon.com/microcontrollers

Microcontrollers



Never stop thinking

Block Diagram

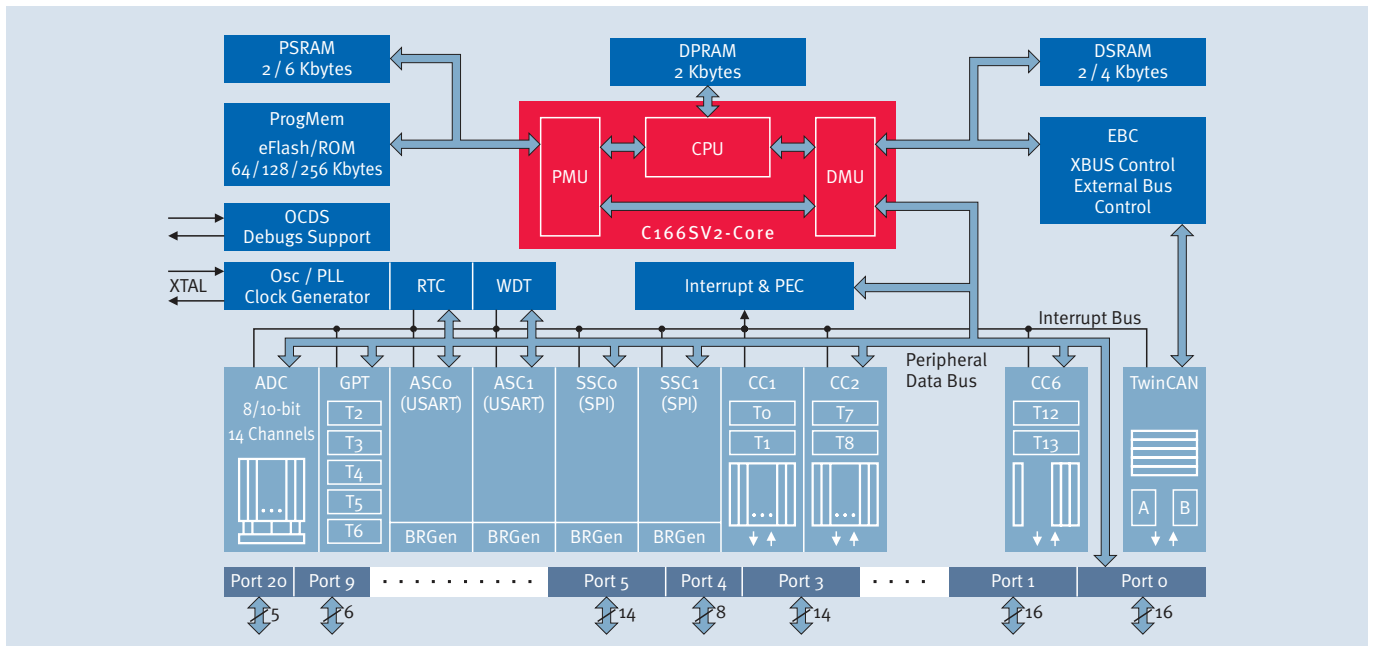

Product Summary

	XC164CS	XC164S	XC164D	XC164N
eFlash [Kbytes] or ROM	64/128/256	64/128/256	64/128/256	64/128/256
RAM [Kbytes]	6/8/12	6/8/12	6/8/12	6/8/12
Package	P/PG-TQFP-100	P/PG-TQFP-100	P/PG-TQFP-100	P/PG-TQFP-100
Frequency [MHz]	20/40	20/40	20/40	20/40
Temperature Range [°C]	-40 ... 85 -40 ... 125	-40 ... 85	-40 ... 85	-40 ... 85
TwinCAN	✓	–	✓	–
A/D Converter	✓	✓	–	–

Application Example

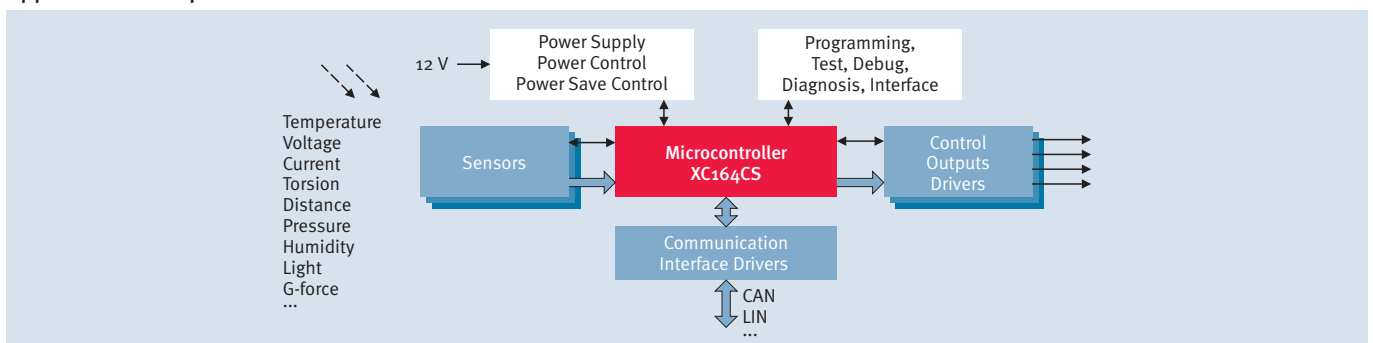

How to reach us:
<http://www.infineon.com>

Published by
 Infineon Technologies AG
 81726 Munich, Germany

© Infineon Technologies AG 2007.
 All Rights Reserved.

Legal Disclaimer

The information given in this Product Brief shall in no event be regarded as a guarantee of conditions or characteristics ("Beschaffenheitsgarantie"). With respect to any examples or hints given herein, any typical values stated herein and/or any information regarding the application of the device, Infineon Technologies hereby disclaims any and all warranties and liabilities of any kind, including without limitation warranties of non-infringement of intellectual property rights of any third party.

Information

For further information on technology, delivery terms and conditions and prices please contact your nearest Infineon Technologies Office (www.infineon.com).

Warnings

Due to technical requirements components may contain dangerous substances. For information on the types in question please contact your nearest Infineon Technologies Office.

Infineon Technologies Components may only be used in life-support devices or systems with the express written approval of Infineon Technologies, if a failure of such components can reasonably be expected to cause the failure of that life-support device or system, or to affect the safety or effectiveness of that device or system.

Life support devices or systems are intended to be implanted in the human body, or to support and/or maintain and sustain and/or protect human life. If they fail, it is reasonable to assume that the health of the user or other persons may be endangered.

Ordering No. B158-H8009-G4-X-7600
 Printed in Germany
 PS 01075 nb