

## BQ76925 3-Series to 6-Series Cell Li-Ion and Li-Phosphate Battery Monitor (Analog Front End)

### 1 Features

- Analog interface for host cell measurement
  - Cell input MUX, level shifter, and scaler
  - 1.5-/ 3.0-V low-drift, calibrated reference allows accurate analog-to-digital conversions
- Analog interface for host current measurement
  - Variable gain current sense amplifier capable of operation with 1-mΩ sense resistor
- Switchable thermistor bias output for host temperature measurements
- Overcurrent comparator with dynamically adjustable threshold
  - Alerts host to potential overcurrent faults
  - Wakes up host on load connect
- Integrated cell balancing FETs
  - Individual host control
  - 50 mA per cell balancing current
- Supports cell sense-line open wire detection
- Integrated 3.3-V regulator for powering micro-controller or LEDs
- I<sup>2</sup>C interface for host communications
  - Optional packet CRC for robust operation
- Supply voltage range from 4.2 V to 26.4 V
- Low power consumption
  - 40 μA typical in NORMAL mode
  - 1.5 μA maximum in SLEEP mode
- 20-pin TSSOP or 24-pin VQFN package

### 2 Applications

- Primary Protection in Li-Ion Battery Packs
  - [Cordless power tools](#)
  - [Light electric vehicles](#) (e-Bike, scooter, for example)
  - [UPS systems](#)
  - [Medical Equipment](#)
  - [Portable Test Equipment](#)

### 3 Description

The BQ76925 host-controlled analog front end (AFE) is part of a complete pack monitoring, balancing, and protection system for 3-, 4-, 5-, or 6-series cell li-ion and li-polymer batteries. The BQ76925 device allows a host controller to monitor individual cell voltages, pack current and temperature easily. The Host may use this information to determine unsafe or faulty operating conditions such as overvoltage, undervoltage, overtemperature, overcurrent, cell imbalance, state of charge, and state of health conditions.

Cell input voltages are level-shifted, multiplexed, scaled, and output for measurement by a host ADC. A dedicated pin provides a low-drift calibrated reference voltage to enable accurate measurements.

#### Device Information<sup>(1)</sup>

PART NUMBER	PACKAGE	BODY SIZE (NOM)
BQ76925	TSSOP (20)	4.00 mm × 4.00 mm
BQ76925	VQFN (24)	6.50 mm × 4.40 mm

(1) For all available packages, see the orderable addendum at the end of the datasheet.

#### Simplified Schematic

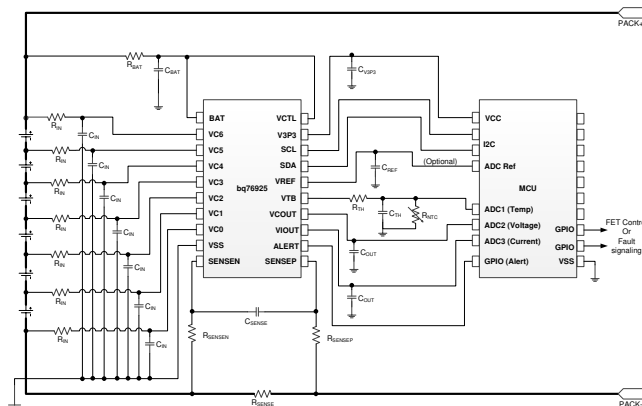

## Table of Contents

<b>1 Features</b> .....	<b>1</b>	<b>8 Detailed Description</b> .....	<b>11</b>
<b>2 Applications</b> .....	<b>1</b>	8.1 Overview .....	11
<b>3 Description</b> .....	<b>1</b>	8.2 Functional Block Diagram .....	12
<b>4 Revision History</b> .....	<b>2</b>	8.3 Feature Description .....	12
<b>5 Description (Continued)</b> .....	<b>3</b>	8.4 Device Functional Modes .....	18
<b>6 Pin Configuration and Functions</b> .....	<b>3</b>	8.5 Programming .....	20
<b>7 Specifications</b> .....	<b>4</b>	8.6 Register Maps .....	22
7.1 Absolute Maximum Ratings .....	4	<b>9 Application and Implementation</b> .....	<b>28</b>
7.2 ESD Ratings .....	4	9.1 Application Information .....	28
7.3 Recommended Operating Conditions .....	5	9.2 Typical Application .....	29
7.4 Thermal Information .....	5	<b>10 Power Supply Recommendations</b> .....	<b>32</b>
7.5 Electrical Characteristics: Supply Current .....	6	<b>11 Layout</b> .....	<b>32</b>
7.6 Internal Power Control (Startup and Shutdown) .....	6	11.1 Layout Guidelines .....	32
7.7 3.3-V Voltage Regulator .....	6	11.2 Layout Example .....	32
7.8 Voltage Reference .....	7	<b>12 Device and Documentation Support</b> .....	<b>34</b>
7.9 Cell Voltage Amplifier .....	7	12.1 Documentation Support .....	34
7.10 Current Sense Amplifier .....	7	12.2 Receiving Notification of Documentation Updates .....	34
7.11 Overcurrent Comparator .....	8	12.3 Support Resources .....	34
7.12 Internal Temperature Measurement .....	8	12.4 Trademarks .....	34
7.13 Cell Balancing and Open Cell Detection .....	8	12.5 Electrostatic Discharge Caution .....	34
7.14 I <sup>2</sup> C Compatible Interface .....	9	12.6 Glossary .....	34
7.15 Typical Characteristics .....	10	<b>13 Mechanical, Packaging, and Orderable Information</b> .....	<b>34</b>

## 4 Revision History

NOTE: Page numbers for previous revisions may differ from page numbers in the current version.

<b>Changes from Revision D (October 2016) to Revision E</b>	<b>Page</b>
• Changed the title of the data sheet .....	1
• Changed ZXTP2504DFH to ZXTP25040DFH .....	28

<b>Changes from Revision C (July 2015) to Revision D</b>	<b>Page</b>
• Added test condition n = 1 – 5 at 25°C and MAX value for I <sub>VCn</sub> parameter .....	6
• Added <i>Receiving Notification of Documentation Updates</i> section .....	34

<b>Changes from Revision B (December 2011) to Revision C</b>	<b>Page</b>
• Added <i>ESD Ratings</i> table, <i>Feature Description</i> section, <i>Device Functional Modes</i> , <i>Application and Implementation</i> section, <i>Power Supply Recommendations</i> section, <i>Layout</i> section, <i>Device and Documentation Support</i> section, and <i>Mechanical, Packaging, and Orderable Information</i> section. ....	1
• Moved content to new sections and added hyperlinks to corresponding sections, figures, tables and documents. ....	1
• Moved R <sub>BAT</sub> , C <sub>BAT</sub> , R <sub>IN</sub> , C <sub>IN</sub> , R <sub>SENSE</sub> , R <sub>SENSEP</sub> , C <sub>SENSE</sub> , R <sub>VCTL</sub> , C <sub>V3P3</sub> , C <sub>REF</sub> , and C <sub>OUT</sub> table rows to <i>Design Requirements</i> ..	5

<b>Changes from Revision A (July 2011) to Revision B</b>	<b>Page</b>
• Added 24-pin QFN (RGE) Package to Production Data .....	3

## 5 Description (Continued)

The voltage across an external-sense resistor is amplified and output to a host ADC for both charge and discharge current measurements. Two gain settings enable operation with a variety of sense resistor values over a wide range of pack currents.

To enable temperature measurements by the host, the AFE provides a separate output pin for biasing an external thermistor network. This output can be switched on and off under host control to minimize power consumption.

The BQ76925 device includes a comparator with a dynamically selectable threshold for monitoring current. The comparator result is driven through an open-drain output to alert the host when the threshold is exceeded. This feature can be used to wake up the host on connection of the load, or to alert the host to a potential fault condition.

The BQ76925 device integrates cell balancing FETs that are fully controlled by the host. The balancing current is set by external resistors up to a maximum value of 50 mA. These same FETs may be utilized in conjunction with cell voltage measurements to detect an open wire on a cell sense-line.

The host communicates with the AFE through an I<sup>2</sup>C interface. A packet CRC may optionally be used to ensure robust operation. The device may be put into a low-current sleep mode through the I<sup>2</sup>C interface and awakened by pulling up the ALERT pin.

## 6 Pin Configuration and Functions

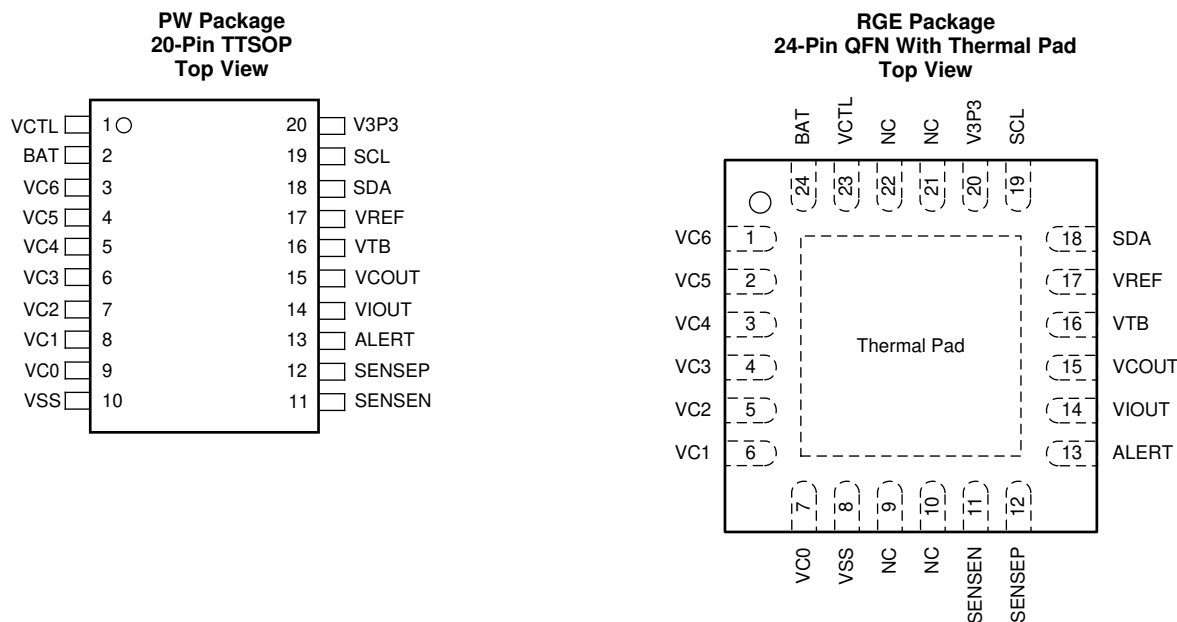

### Pin Functions

NAME	PIN NO.		TYPE	DESCRIPTION
	TSSOP	VQFN		
VCTL	1	23	Output	3.3-V Regulator control voltage <sup>(1)</sup>
ALERT	13	13	Output	Overcurrent alert (open drain)
BAT	2	24	Power	Supply voltage, tied to most positive cell
NC	—	9, 10, 21, 22	—	No Connection (leave open)
SCL	19	19	Input	I <sup>2</sup> C Clock (open drain)
SDA	18	18	Input / Output	I <sup>2</sup> C Data (open drain)
SENSEN	11	11	Input	Negative current sense

(1) When a bypass FET is used to supply the regulated 3.3-V load current, VCTL automatically adjusts to keep V3P3 = 3.3 V. If VCTL is tied to BAT, the load current is supplied through V3P3.

**Pin Functions (continued)**

NAME	PIN NO.		TYPE	DESCRIPTION
	TSSOP	VQFN		
SENSEP	12	12	Input	Positive current sense
V3P3	20	20	Output	3.3-V Regulator
VC6	3	1	Input	Sense voltage for most positive cell
VC5	4	2	Input	Sense voltage for second most positive cell
VC4	5	3	Input	Sense voltage for third most positive cell
VC3	6	4	Input	Sense voltage for fourth most positive cell
VC2	7	5	Input	Sense voltage for fifth most positive cell
VC1	8	6	Input	Sense voltage for least positive cell
VC0	9	7	Input	Sense voltage for negative end of cell stack
VCOUT	15	15	Output	Cell measurement voltage
VIOUT	14	14	Output	Current measurement voltage
VREF	17	17	Output	Reference voltage for ADC
VSS	10	8	Power	Ground
VTB	16	16	Output	Bias voltage for thermistor network

**7 Specifications**

**7.1 Absolute Maximum Ratings**

over operating free-air temperature range (unless otherwise noted) <sup>(1)</sup>

			MIN	MAX	UNIT
V <sub>BAT</sub>	Supply voltage	BAT	-0.3	36	V
V <sub>I</sub>	Input voltage	Cell input differential, VC <sub>n</sub> to VC <sub>n+1</sub> , n = 0 to 5	-0.3	9	V
		Cell input, VC <sub>n</sub> , n = 1 to 6	-0.3	(6 × n)	
		BAT to VC6 differential	-10	10	
		VC0 <sup>(2)</sup>	-3	3	
		SENSEP, SENSEN	-3	3	
		SCL, SDA	-0.3	6	
V <sub>O</sub>	Output voltage	VCOUT, VIOUT, VREF	-0.3	3.6	V
		VTB, V3P3	-0.3	7	
		ALERT	-0.3	30	
		VCTL	-0.3	36	
I <sub>CB</sub>	Cell balancing current		70	mA	
I <sub>IN</sub>	Cell input current		-25	70	mA
T <sub>stg</sub>	Storage temperature		-65	150	°C

- (1) Stresses beyond those listed under *Absolute Maximum Ratings* may cause permanent damage to the device. These are stress ratings only, which do not imply functional operation of the device at these or any other conditions beyond those indicated under *Recommended Operating Conditions*. Exposure to absolute-maximum-rated conditions for extended periods may affect device reliability.
- (2) Negative voltage swings on VC0 in the absolute maximum range can cause unwanted circuit behavior and should be avoided.

**7.2 ESD Ratings**

			VALUE	UNIT
V <sub>(ESD)</sub>	Electrostatic discharge	Human-body model (HBM), per ANSI/ESDA/JEDEC JS-001 <sup>(1)</sup>	±2000	V
		Charged-device model (CDM), per JEDEC specification JESD22-C101 <sup>(2)</sup>	±500	

- (1) JEDEC document JEP155 states that 500-V HBM allows safe manufacturing with a standard ESD control process.
- (2) JEDEC document JEP157 states that 250-V CDM allows safe manufacturing with a standard ESD control process.

### 7.3 Recommended Operating Conditions<sup>(1)</sup>

		MIN	NOM	MAX	UNIT		
Supply voltage	BAT	4.2		26.4	V		
V <sub>I</sub>	Input voltage	Cell input differential, VCn to VCn+1, n = 0 to 5		1.4	4.4	V	
		Cell input, VCn, n = 1 to 6			4.4 × n	V	
		BAT to VC6 differential		−8		8	V
		VC0, SENSEN			0		V
		SENSEP		−125		375	mV
		SCL, SDA		0		5.5	V
		V3P3	Backfeeding <sup>(2)</sup>			5.5	V
		ALERT	Wakeup function	0		26.4	V
V <sub>O</sub>	Output voltage	VCOUT, VIOUT		0	V3P3 + 0.2	V	
		VREF	REFSEL = 0		1.5	V	
			REFSEL = 1		3	V	
		VTB				5.5	V
		V3P3	Regulating		3.3		V
		VCTL		0.8		26.4	V
		ALERT	Alert function	0		5.5	V
I <sub>CB</sub>	Cell balancing current	0		50	mA		
T <sub>A</sub>	Operating free-air temperature	−25		85	°C		
T <sub>FUNC</sub>	Functional free-air temperature	−40		100	°C		

(1) All voltages are relative to VSS, except “Cell input differential.”

(2) Internal 3.3-V regulator may be overridden (that is, backfed) by applying an external voltage larger than the regulator voltage.

### 7.4 Thermal Information

THERMAL METRIC <sup>(1)</sup>	BQ76925		UNIT	
	PW (TSSOP)	RGE (VQFN)		
	20 PINS	24 PINS		
R <sub>θJA</sub>	Junction-to-ambient thermal resistance	97.5	36	°C/W
R <sub>θJC (top)</sub>	Junction-to-case (top) thermal resistance	31.7	38.6	°C/W
R <sub>θJB</sub>	Junction-to-board thermal resistance	48.4	14	°C/W
ψ <sub>JT</sub>	Junction-to-top characterization parameter	1.5	0.6	°C/W
ψ <sub>JB</sub>	Junction-to-board characterization parameter	47.9	14	°C/W
R <sub>θJC (bot)</sub>	Junction-to-case (bottom) thermal resistance	n/a	4.6	°C/W

(1) For more information about traditional and new thermal metrics, see the [Semiconductor and IC Package Thermal Metrics](#) application report.

## 7.5 Electrical Characteristics: Supply Current

 BAT = 4.2 to 26.4 V, V<sub>CN</sub> = 1.4 to 4.4, T<sub>A</sub> = –25°C to +85°C

 Typical values stated where T<sub>A</sub> = 25°C and BAT = 21.6 V (unless otherwise noted)

PARAMETER		TEST CONDITION		MIN	TYP	MAX	UNIT
I <sub>DD1</sub>	Normal mode supply current	All device functions enabled All pins unloaded SDA and SCL high			40	48	μA
I <sub>DD2</sub>	Standby mode 1 supply current	V3P3 and overcurrent monitor enabled All pins unloaded All other device functions disabled SDA and SCL high			14	17	μA
I <sub>DD3</sub>	Standby mode 2 supply current	V3P3 enabled All pins unloaded All device functions disabled SDA and SCL high			12	14	V
I <sub>DD4</sub>	Sleep mode supply current	V3P3 disabled All pins unloaded All device functions disabled SDA and SCL low			1	1.5	μA
I <sub>VCN</sub>	Input current for selected cell	All cell voltages equal Cell balancing disabled Open cell detection disabled during cell voltage monitoring	n = 6		2.4	2.7	μA
			n = 1 – 5			< 0.5	
			n = 1 – 5 at 25°C			< 0.3	
ΔI <sub>VCN</sub>	Cell to cell input current difference	All cell voltages equal Cell balancing disabled Open cell detection disabled				< 0.2	μA

## 7.6 Internal Power Control (Startup and Shutdown)

PARAMETER		TEST CONDITION		MIN	TYP	MAX	UNIT
V <sub>POR</sub>	Power on reset voltage	Measured at BAT pin	Initial BAT < 1.4 VBAT rising <sup>(1)</sup>	4.3	4.5	4.7	V
			Initial BAT > 1.4 VBAT rising <sup>(1)</sup>	6.5	7	7.5	V
V <sub>SHUT</sub>	Shutdown voltage <sup>(2)</sup>	Measured at BAT pin, BAT falling				3.6	V
t <sub>POR</sub>	Time delay after POR before I2C comms allowed	CV3P3 = 4.7 μF				1	ms
V <sub>WAKE</sub>	Wakeup voltage	Measured at ALERT pin		0.8		2	V
t <sub>WAKE_PLS</sub>	Wakeup signal pulse width			1		5	μs
t <sub>WAKE_DLY</sub>	Time delay after wakeup before I2C comms allowed	CV3P3 = 4.7 μF				1	ms

(1) Initial power up will start with BAT < 1.4 V, however if BAT falls below V<sub>SHUT</sub> after rising above V<sub>POR</sub>, the power on threshold depends on the minimum level reached by BAT after falling below V<sub>SHUT</sub>.

(2) Following POR, the device will operate down to this voltage.

## 7.7 3.3-V Voltage Regulator

PARAMETER		TEST CONDITION		MIN	TYP	MAX	UNIT
V <sub>CTL</sub>	Regulator control voltage <sup>(1)(2)</sup>	Measured at VCTL, V3P3 regulating		3.3		26.4	V
V <sub>V3P3</sub>	Regulator output	Measured at V3P3, I <sub>REG</sub> = 0 to 4 mA, BAT = 4.2 to 26.4 V		3.2	3.3	3.4	V
I <sub>REG</sub>	V3P3 output current					4	mA
I <sub>SC</sub>	V3P3 short circuit current limit	V3P3 = 0.0 V		10		17	mA
V <sub>TB</sub>	Thermistor bias voltage	Measured at VTB, I <sub>TB</sub> = 0			V <sub>V3P3</sub>		V
I <sub>TB</sub>	Thermistor bias current					1	mA
R <sub>TB</sub>	Thermistor bias internal resistance	R <sub>DS(ON)</sub> for internal FET switch, I <sub>TB</sub> = 1 mA			90	130	Ω

(1) When a bypass FET is used to supply the regulated 3.3 V load current, VCTL automatically adjusts to keep V3P3 = 3.3 V. Note that V<sub>CTL,MIN</sub> and the FET V<sub>GS</sub> will determine the minimum BAT voltage at which the bypass FET will operate.

(2) If VCTL is tied to BAT, the load current is supplied through V3P3.

## 7.8 Voltage Reference

PARAMETER		TEST CONDITION		MIN	TYP	MAX	UNIT
V <sub>REF</sub>	Voltage reference output	Before gain correction, T <sub>A</sub> = 25°C	REF_SEL = 0	1.44		1.56	V
			REF_SEL = 1		2.88	3.12	
		After gain correction, <sup>(1)</sup> T <sub>A</sub> = 25°C	REF_SEL = 0	-0.1%	1.5	+0.1%	
			REF_SEL = 1	-0.1%	3	+0.1%	
V <sub>REF_CAL</sub>	Reference calibration voltage	Measured at V <sub>COUT</sub>	V <sub>COUT_SEL</sub> = 2	-0.9%	0.5 × V <sub>REF</sub>	+0.9%	V
			V <sub>COUT_SEL</sub> = 3	-0.5%	0.85 × V <sub>REF</sub>	+0.5%	V
			(0.85 × V <sub>REF</sub> ) – (0.5 × V <sub>REF</sub> )	-0.3%	0.35 × V <sub>REF</sub>	+0.3%	V
ΔV <sub>REF</sub>	Voltage reference tolerance	T <sub>A</sub> = 0 – 50°C		-40		40	ppm/°C
I <sub>REF</sub>	V <sub>REF</sub> output current					10	μA

(1) Gain correction factor determined at final test and stored in non-volatile storage. Gain correction is applied by Host controller.

## 7.9 Cell Voltage Amplifier

PARAMETER		TEST CONDITION		MIN	TYP	MAX	UNIT
G <sub>V<sub>COUT</sub></sub>	Cell voltage amplifier gain	Measured from VC <sub>n</sub> to V <sub>COUT</sub>	REF_SEL = 0	-1.6%	0.3	1.5%	
			REF_SEL = 1	-1.6%	0.6	1.5%	
O <sub>V<sub>COUT</sub></sub>	Cell voltage amplifier offset	Measured from VC <sub>n</sub> to V <sub>COUT</sub>		-16		15	mV
V <sub>COUT</sub>	Cell voltage amp output range <sup>(1)</sup>	Measured at V <sub>COUT</sub> , VC <sub>n</sub> = 5 V	REF_SEL = 0	1.47	1.5	1.53	V
			REF_SEL = 1	2.94	3	3.06	V
		Measured at V <sub>COUT</sub> , VC <sub>n</sub> = 0 V			0		V
ΔV <sub>COUT</sub>	Cell voltage amplifier accuracy	VC <sub>n</sub> = 1.4 V to 4.4 V, After correction, <sup>(2)</sup> Measured at V <sub>COUT</sub> <sup>(3)</sup> REF_SEL = 1 <sup>(4)</sup>	T <sub>A</sub> = 25°C	-3		3	mV
			T <sub>A</sub> = 0°C to 50°C	-5		5	
			T <sub>A</sub> = -25°C to +85°C	-8		8	
I <sub>V<sub>COUT</sub></sub>	V <sub>COUT</sub> output current <sup>(5)</sup>					10	μA
t <sub>V<sub>COUT</sub></sub>	Delay from VC <sub>n</sub> select to V <sub>COUT</sub>	Output step of 200 mV, C <sub>OUT</sub> = 0.1 μF				100	μs

(1) For VC<sub>n</sub> values greater than 5 V, V<sub>COUT</sub> clamps at approximately V<sub>3P3</sub>.

(2) Correction factor determined at final test and stored in non-volatile storage. Correction is applied by Host controller.

(3) Output referred. Input referred accuracy is calculated as ΔV<sub>COUT</sub> / G<sub>V<sub>COUT</sub></sub> (for example, 3 / 0.6 = 5).

(4) Correction factors are calibrated for gain of 0.6. Tolerance at gain of 0.3 is approximately doubled. Contact TI for information on devices calibrated to a gain of 0.3.

(5) Max DC load for specified accuracy.

## 7.10 Current Sense Amplifier

PARAMETER		TEST CONDITION		MIN	TYP	MAX	UNIT
G <sub>V<sub>IOUT</sub></sub>	Current sense amplifier gain	Measured from SENSEN, SENSEP to V <sub>IOUT</sub>	I_GAIN = 0		4		
			I_GAIN = 1		8		
V <sub>IIN</sub>	Current sense amp input range	Measured from SENSEN, SENSEP to V <sub>SS</sub>		-125		375	mV
V <sub>IOUT</sub>	Current sense amp output range	Measured at V <sub>IOUT</sub>	REF_SEL = 0	0.25		1.25	V
			REF_SEL = 1	0.5		2.5	V
	Zero current output	Measured at V <sub>IOUT</sub> SENSEP = SENSEN	REF_SEL = 0		1		V
			REF_SEL = 1		2		V
ΔV <sub>IOUT</sub>	Current amplifier accuracy			-1%		1%	
I <sub>V<sub>IOUT</sub></sub>	V <sub>IOUT</sub> output current <sup>(1)</sup>					10	μA

(1) Max DC load for specified accuracy

## 7.11 Overcurrent Comparator

PARAMETER	TEST CONDITION	MIN	TYP	MAX	UNIT	
V <sub>BAT_COMP</sub>	Minimum VBAT for comparator operation <sup>(1)</sup>			5	V	
G <sub>VCOMP</sub>	Comparator amplifier gain	Measured from SENSEP to comparator input		1		
V <sub>ITRIP</sub>	Current comparator trip threshold <sup>(2)</sup>	25		400	mV	
ΔV <sub>ITRIP</sub>	Current comparator accuracy	V <sub>ITRIP</sub> = 25 mV		-6	6	mV
		V <sub>ITRIP</sub> > 25 mV		-10%	10%	V
V <sub>OL_ALERT</sub>	ALERT Output Low Logic	I <sub>ALERT</sub> = 1 mA		0.4	V	
V <sub>OH_ALERT</sub>	ALERT Output High Logic <sup>(3)</sup>	NA	NA	NA		
I <sub>ALERT</sub>	ALERT Pulldown current	ALERT = 0.4 V, Output driving low		1	mA	
I <sub>ALERT_LKG</sub>	ALERT Leakage current	ALERT = 5 V, Output Hi-Z		< 1	μA	
t <sub>OC</sub>	Comparator response time			100	μs	

(1) The Overcurrent Comparator is not guaranteed to work when VBAT is below this voltage.

(2) Trip threshold selectable from 25, 50, 75, 100, 125, 150, 175, 200, 225, 250, 275, 300, 325, 350, 375 or 400 mV.

(3) This parameter NA because output is open drain.

## 7.12 Internal Temperature Measurement

PARAMETER	TEST CONDITION	MIN	TYP	MAX	UNIT		
V <sub>TEMP_INT</sub>	Internal temperature voltage	Measured at V <sub>COU</sub> T, T <sub>INT</sub> = 25°C		1.15	1.2	1.25	V
ΔV <sub>TEMP_INT</sub>	Internal temperature voltage sensitivity		-4.4			mV/°C	

## 7.13 Cell Balancing and Open Cell Detection

PARAMETER	TEST CONDITION	MIN	TYP	MAX	UNIT
R <sub>BAL</sub>	R <sub>DS(ON)</sub> for VC1 internal FET switch, VC <sub>n</sub> = 3.6 V	1	3	5	Ω
	R <sub>DS(ON)</sub> for internal VC2 to VC6 FET switch, VC <sub>n</sub> = 3.6 V	3	5.5	8	

(1) Balancing current is not internally limited. The cell balancing operation is completely controlled by the Host processor, no automatic function or time-out is included in the part. Take care to ensure that balancing current through the part is below the maximum power dissipation limit. The Host algorithm is responsible for limiting thermal dissipation to package ratings.



### 7.14 I<sup>2</sup>C Compatible Interface

PARAMETERS		MIN	TYP	MAX	UNIT
<b>DC PARAMETERS</b>					
V <sub>IL</sub>	Input Low Logic Threshold			0.6	V
V <sub>IH</sub>	Input High Logic Threshold	2.8			V
V <sub>OL</sub>	Output Low Logic Drive	I <sub>OL</sub> = 1 mA		0.20	V
		I <sub>OL</sub> = 2.5 mA		0.40	
V <sub>OH</sub>	Output High Logic Drive (Not applicable due to open-drain outputs)		N/A		V
I <sub>LKG</sub>	I <sup>2</sup> C Pin Leakage	Pin = 5 V, Output in Hi-Z		< 1	μA
<b>AC PARAMETERS</b>					
t <sub>r</sub>	SCL, SDA Rise Time			1000	ns
t <sub>f</sub>	SCL, SDA Fall Time			300	ns
t <sub>w(H)</sub>	SCL Pulse Width High	4			μs
t <sub>w(L)</sub>	SCL Pulse Width Low	4.7			μs
t <sub>su(STA)</sub>	Setup time for START condition	4.7			μs
t <sub>h(STA)</sub>	START condition hold time after which first clock pulse is generated	4			μs
t <sub>su(DAT)</sub>	Data setup time	250			ns
t <sub>h(DAT)</sub>	Data hold time	0 <sup>(1)</sup>			μs
t <sub>su(STOP)</sub>	Setup time for STOP condition	4			μs
t <sub>su(BUF)</sub>	Time the bus must be free before new transmission can start	4.7			μs
t <sub>v</sub>	Clock Low to Data Out Valid			900	ns
t <sub>h(CH)</sub>	Data Out Hold Time After Clock Low	0			ns
f <sub>SCL</sub>	Clock Frequency	0		100	kHz
t <sub>WAKE</sub>	I <sup>2</sup> C ready after transition to Wake Mode			2.5	ms

(1) Devices must provide internal hold time of at least 300 ns for the SDA signal-to-bridge of the undefined region of the falling edge of SCL.

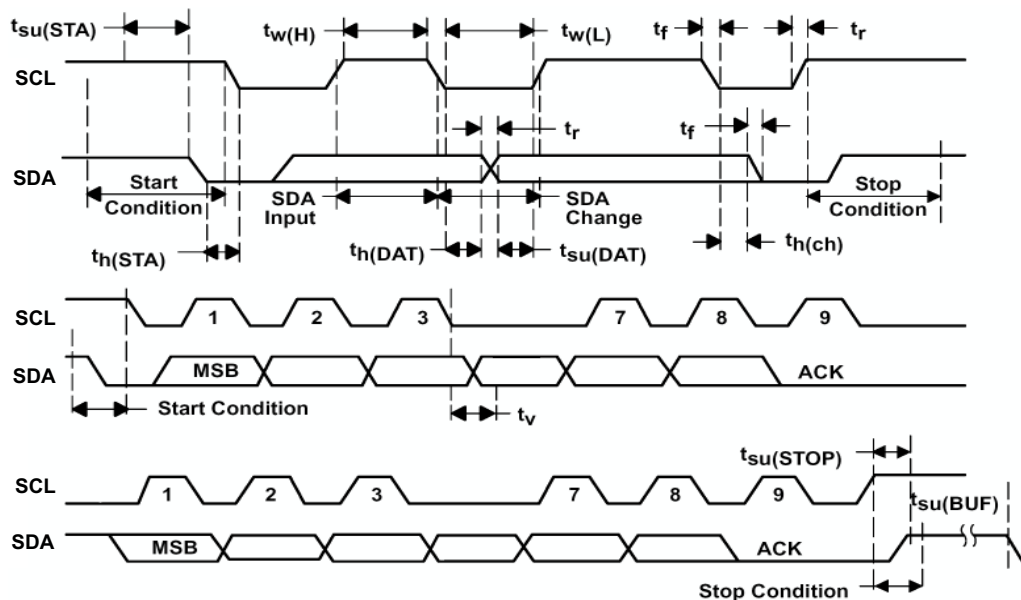
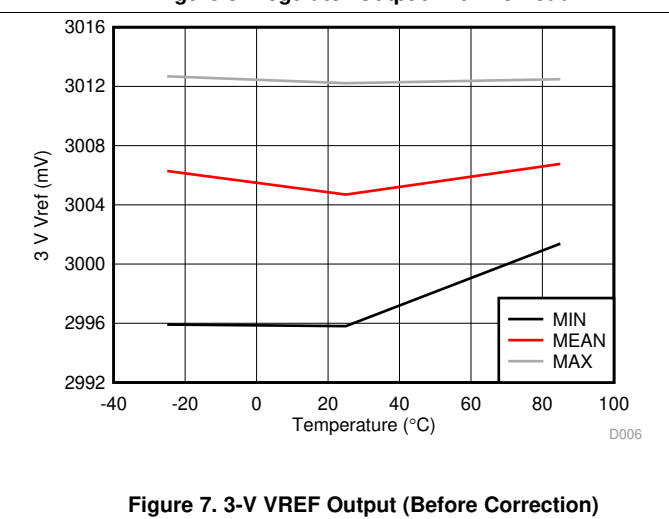
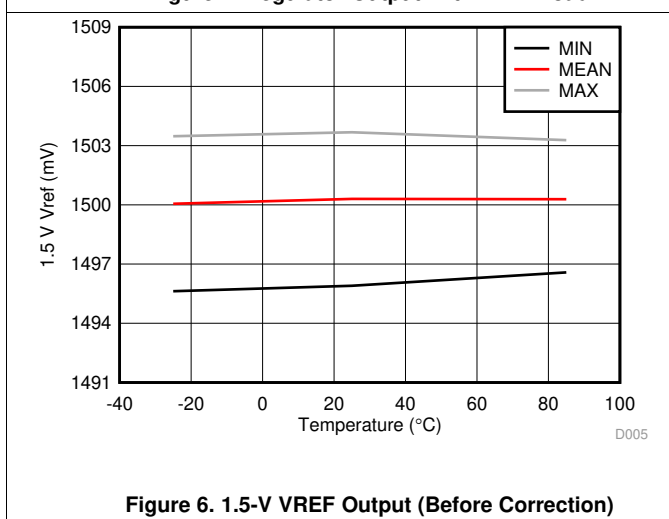
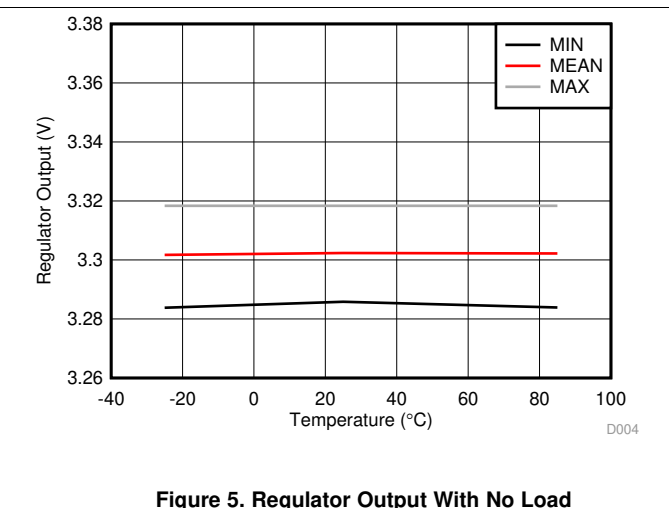
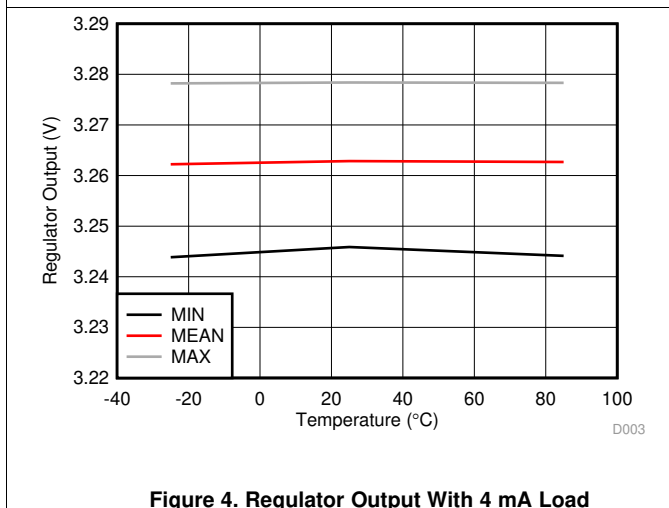
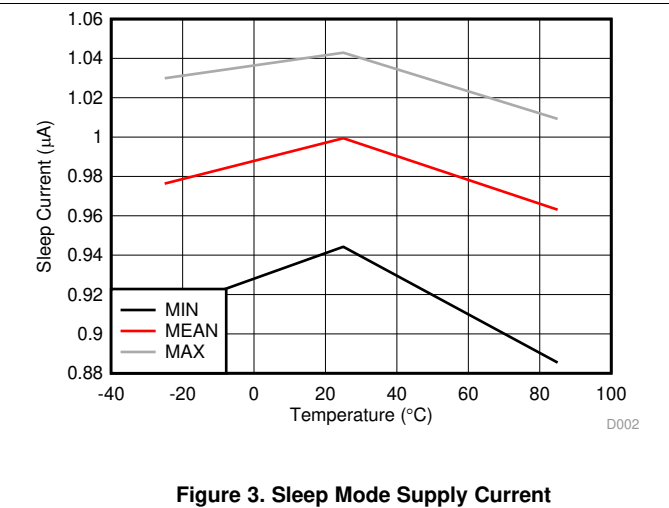
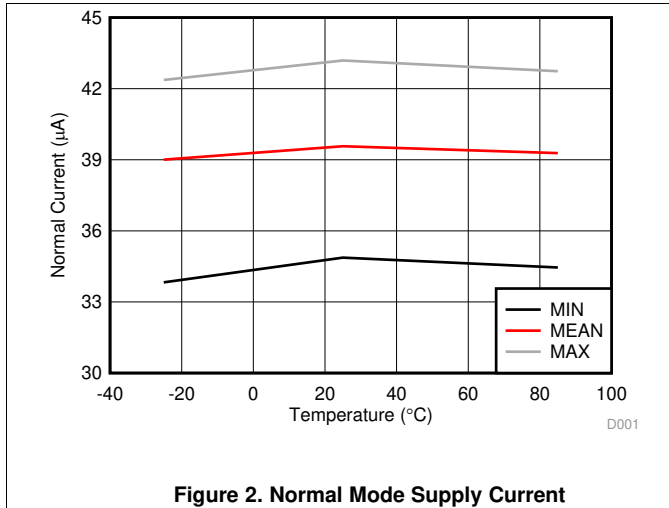

Figure 1. I<sup>2</sup>C Timing

### 7.15 Typical Characteristics



## 8 Detailed Description

### 8.1 Overview

The BQ76925 Host-controlled analog front end (AFE) is part of a complete pack monitoring, balancing, and protection system for 3-series to 6-series cell Lithium batteries. The BQ76925 allows a Host controller to easily monitor individual cell voltages, pack current, and temperature. The Host may use this information to detect and act on a fault condition caused when one or more of these parameters exceed the limits of the application. In addition, the Host may use this information to determine end-of-charge, end-of-discharge, and other gas-gauging and state of health conditions.

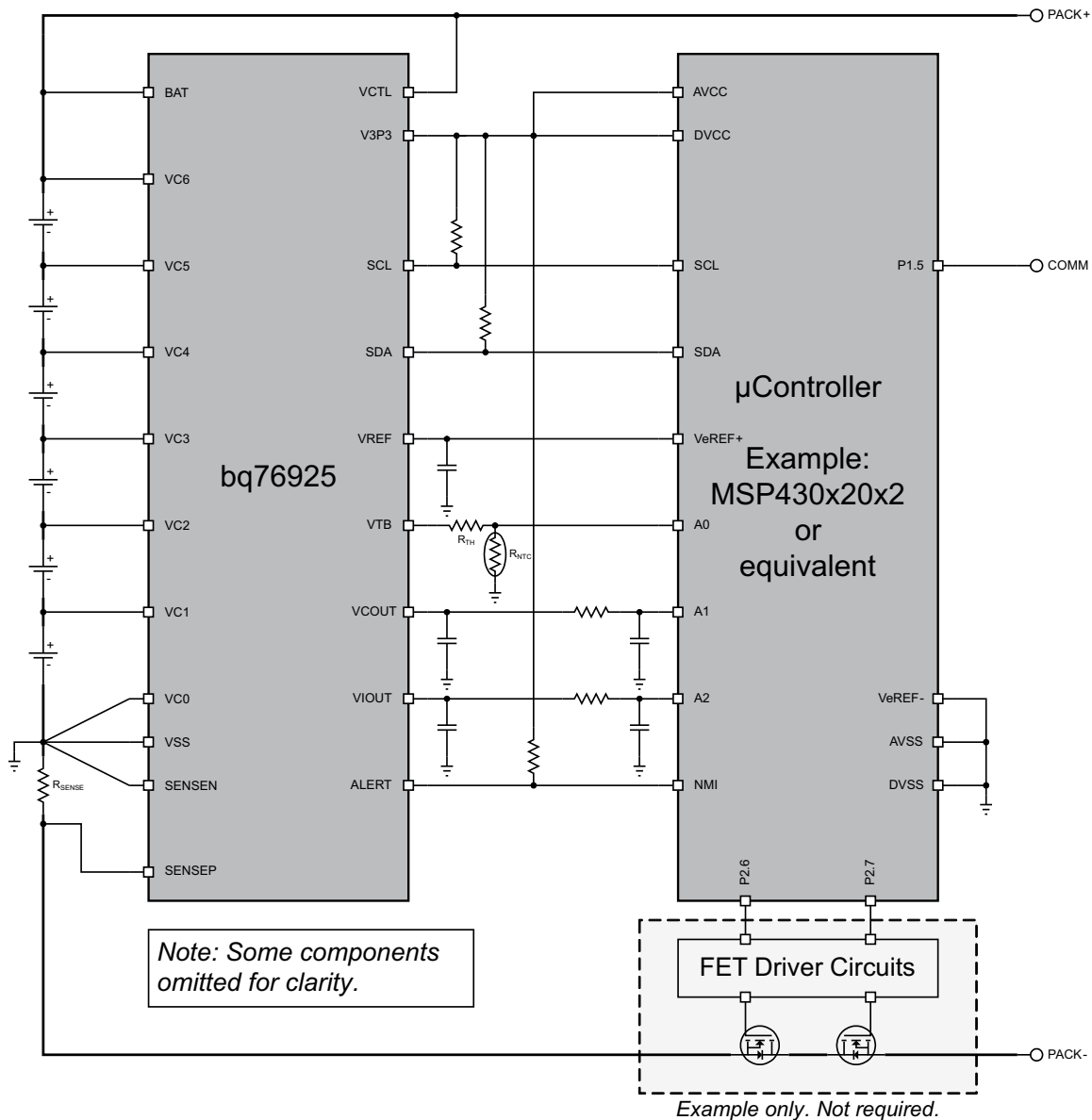
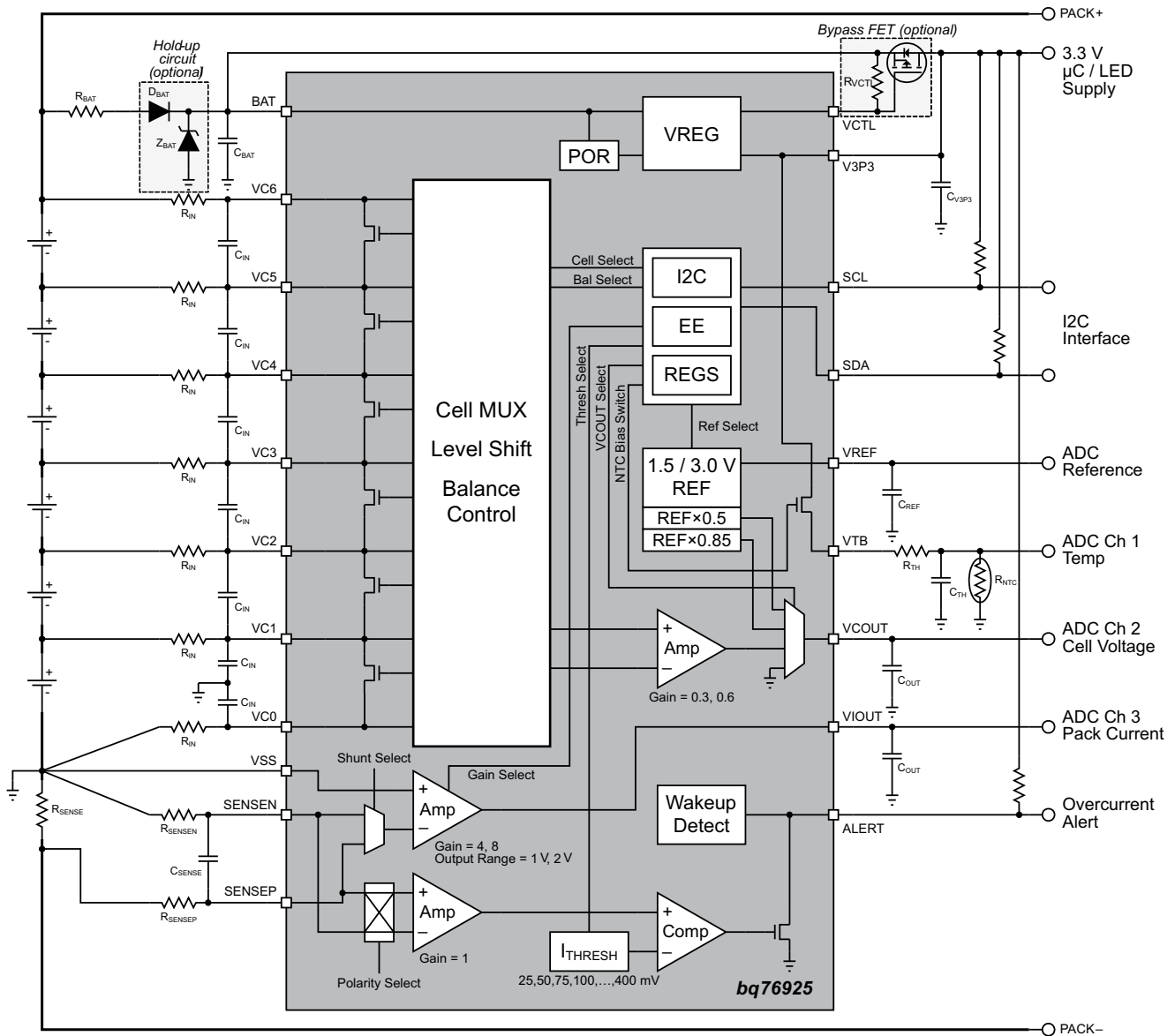

Figure 8. Example of BQ76925 With Host Controller

## 8.2 Functional Block Diagram



## 8.3 Feature Description

### 8.3.1 Internal LDO Voltage Regulator

The BQ76925 device provides a regulated 3.3-V supply voltage on the V3P3 pin for operating the device's internal logic and interface circuitry. This regulator may also be used to directly power an external microcontroller or other external circuitry up to a limit of 4-mA load current. In this configuration, the VCTL pin is tied directly to the BAT pin. For applications requiring more than 4 mA, an external-bypass transistor may be used to supply the load current. In this configuration, the VCTL pin is tied to the gate of the bypass FET. These two configurations are shown in [Figure 9](#).

## Feature Description (continued)

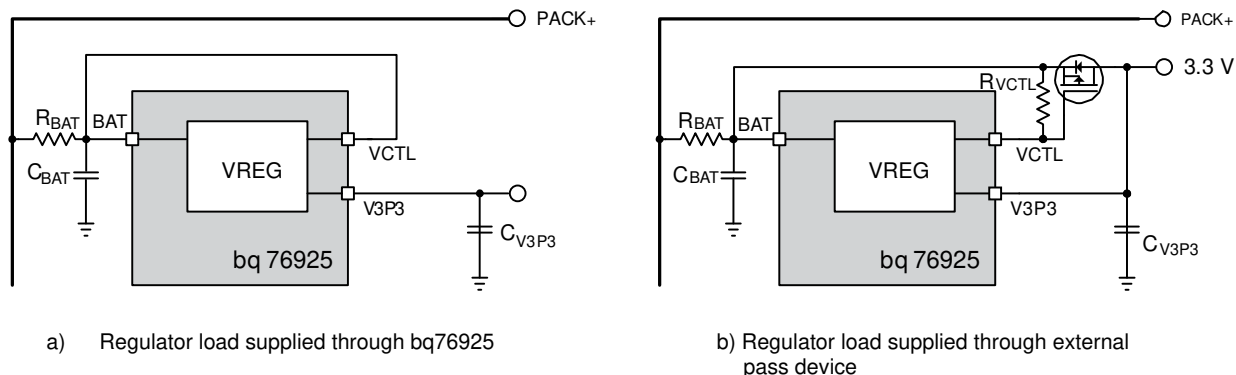

**Figure 9. LDO Regulator Configurations**

For the configuration of [Figure 9b](#)), a high-gain bypass device should be used to ensure stability. A bipolar PNP or p-channel FET bypass device may be used. Contact TI for recommendations.

The LDO regulator may be overridden (that is, back-fed) by an external-supply voltage greater than the regulated voltage on V3P3. In this configuration, the BQ76925 internal logic and interface circuitry operates from the external supply and the internal 3.3-V regulator supplies no load current.

### 8.3.2 ADC Interface

The BQ76925 device is designed to interface to a multi-channel analog-to-digital converter (ADC) located in an external Host controller, such as an MSP430 Microcontroller or equivalent. Three outputs provide voltage, current, and temperature information for measurement by the Host. In addition, the BQ76925 device includes a low-drift calibrated 1.5 / 3 V reference that is output on a dedicated pin for use as the reference input to the ADC.

The gain and offset characteristics of the BQ76925 device are measured during factory test and stored in non-volatile memory as correction factors. The Host reads these correction factors and applies them to the ADC conversion results in order to achieve high-measurement accuracy. In addition, the precise voltage reference of the BQ76925 can be used to calibrate the gain and offset of the Host ADC.

#### 8.3.2.1 Reference Voltage

The BQ76925 device outputs a stable reference voltage for use by the Host ADC. A nominal voltage of 1.5 V or 3 V is selected through the REF\_SEL bit in the CONFIG\_2 register. The reference voltage is very stable across temperature, but the initial voltage may vary by  $\pm 4\%$ . The variation from nominal is manifested as a gain error in the ADC conversion result. To correct for this error, offset and gain correction factors are determined at final test and stored in the non-volatile registers VREF\_CAL and VREF\_CAL\_EXT. The Host reads the correction factors and applies them to the nominal reference voltage to arrive at the actual reference voltage as described under [Cell Voltage Monitoring](#). After gain correction, the tolerance of the reference will be within  $\pm 0.1\%$ .

##### 8.3.2.1.1 Host ADC Calibration

All analog-to-digital converters have inherent gain and offset errors, which adversely affect measurement accuracy. Some microcontrollers may be characterized by the manufacturer and shipped with ADC gain and offset information stored on-chip. It is also possible for such characterization to be done by the end-user on loose devices prior to PCB assembly or as a part of the assembled PCB test.

For applications where such ADC characterization is not provided or is not practical, the BQ76925 device provides a means for in-situ calibration of the Host ADC through setting of the VCOUT\_SEL bits in the CELL\_CTL register two scaled versions of the reference voltage,  $0.5 \times V_{REF}$  and  $0.85 \times V_{REF}$ , can be selected for output on the VCOUT pin for measurement by the Host ADC. Measuring both scaled voltages enables the Host to do a two-point calibration of the ADC and compensate for the ADC offset and gain in all subsequent ADC measurement results as shown in [Figure 10](#).

## Feature Description (continued)

Note that the calibration accuracy will be limited by the tolerance of the scaled reference-voltage output so that use of this method may not be effective. For these cases, TI recommends to use a higher-accuracy source for the two-point calibration shown in Figure 10.

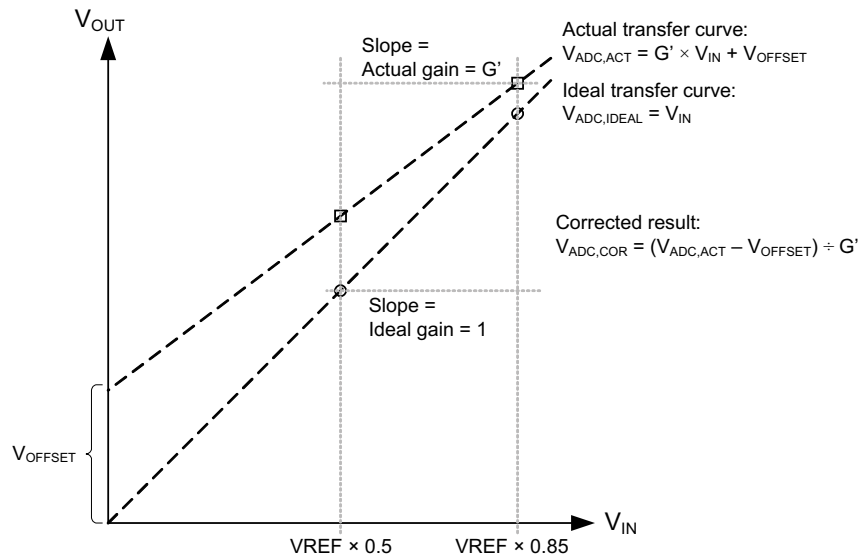

**Figure 10. Host ADC Calibration Using  $V_{REF}$**

### 8.3.2.2 Cell Voltage Monitoring

The cell-voltage monitoring circuits include an input level-shifter, multiplexer (MUX), and scaling amplifier. The Host selects one  $VC_n$  cell input for measurement by setting the  $V_{COUT\_SEL}$  and  $CELL\_SEL$  bits in the  $CELL\_CTL$  register. The scaling factor is set by the  $REF\_SEL$  bit in the  $CONFIG\_2$  register. The selected cell input is level shifted to  $V_{SS}$  reference, scaled by a nominal gain  $G_{V_{COUT}} = 0.3$  ( $REF\_SEL = 0$ ) or  $0.6$  ( $REF\_SEL = 1$ ) and output on the  $V_{COUT}$  pin for measurement by the Host ADC.

Similar to the reference voltage, gain and offset correction factors are determined at final test for each individual cell input and stored in non-volatile registers  $VC_n\_CAL$  ( $n = 1-6$ ) and  $VC\_CAL\_EXT_m$  ( $m = 1-2$ ). These factors are read by the Host and applied to the ADC voltage-measurement results in order to obtain the specified accuracy.

The cell voltage offset and gain correction factors are stored as 5-bit signed integers in 2's complement format. The most significant bits ( $VC_n\_OC\_4$ ,  $VC_n\_GC\_4$ ) are stored separately and must be concatenated with the least significant bits ( $VC_n\_OFFSET\_CORR$ ,  $VC_n\_GAIN\_CORR$ ).

The reference voltage offset and gain correction factors are stored respectively as a 6-bit and 5-bit signed integer in 2's complement format. As with the cell voltage correction factors, the most significant bits ( $V_{REF\_OC\_5}$ ,  $V_{REF\_OC\_4}$ ,  $V_{REF\_GC\_4}$ ) are stored separately and must be concatenated with the least significant bits ( $V_{REF\_OFFSET\_CORR}$ ,  $V_{REF\_GAIN\_CORR}$ ).

The actual cell voltage ( $VC_n$ ) is calculated from the measured voltage ( $V_{COUT}$ ) as shown in the following equations:

$$V_{COUT} = \frac{\text{ADC Count}}{\text{Full Scale Count}} \times V_{REF\_NOMINAL}$$

$$V_{Cn} = \frac{V_{COUT} \times GC_{V_{REF}} + OC_{V_{COUT}}}{G_{V_{COUT}}} \times (1 + GC_{V_{COUT}}) \quad (1)$$

## Feature Description (continued)

$$GC_{VCOUT} = [(VCn\_GC\_4 \ll 4) + VCn\_GAIN\_CORR] \times 0.001,$$

$$OC_{VCOUT} = [(VCn\_OC\_4 \ll 4) + VCn\_OFFSET\_CORR] \times 0.001,$$

$$GC_{VREF} = (1 + [(VREF\_GC\_4 \ll 4) + VREF\_GAIN\_CORR]) \times 0.001$$

$$+ \frac{[(VREF\_OC\_5 \ll 5) + (VREF\_OC\_4 \ll 4) + VREF\_OFFSET\_CORR]}{VREF_{NOMINAL}} \times 0.001 \quad (2)$$

### 8.3.2.2.1 Cell Amplifier Headroom Under Extreme Cell Imbalance

For cell voltages across (VC1 – VC0) that are less than approximately 2.64 V, extreme cell-voltage imbalances between (VC1 – VC0) and (VC2 – VC1) can lead to a loss of gain in the (VC2 – VC1) amplifier. The cell imbalance at which the loss of gain occurs is determined by [Equation 3](#):

$$(VC2 - VC1) \times 0.6 > (VC1 - VSS) \quad (3)$$

Assuming VC0 = VSS, it can be seen that when (VC1 – VC0) > 2.64 volts, the voltage across (VC2 – VC1) can range up to the limit of 4.4 V without any loss of gain. At the minimum value of (VC1 – VC0) = 1.4 V, an imbalance of more than 900 mV is tolerated before any loss of gain in the (VC2 – VC1) amplifier. For higher values of (VC1 – VC0), increasingly large imbalances are tolerated. For example, when (VC1 – VC0) = 2.0 V, an imbalance up to 1.33 V (that is, (VC2 – VC1) = 3.33 V) results in no degradation of amplifier performance.

Normally, cell imbalances greater than 900 mV will signal a faulty condition of the battery pack and its use should be discontinued. *The loss of gain on the second cell input does not affect the ability of the system to detect this condition. The gain fall-off is gradual so that the measured imbalance will never be less than the critical imbalance set by [Equation 3](#).*

Therefore, if the measured (VC2 – VC1) is greater than (VC1 – VSS) / 0.6, a severe imbalance is detected and the pack should enter a fault state which prevents further use. In this severe cell imbalance condition comparisons of the measured (VC2 – VC1) to any overvoltage limits will be optimistic due to the reduced gain in the amplifier, further emphasizing the need to enter a fault state.

### 8.3.2.2.2 Cell Amplifier Headroom Under BAT Voltage Drop

Voltage differences between BAT and the top cell potential come from two sources as shown in [Figure 11](#): V3P3 regulator current that flows through the R<sub>BAT</sub> filter resistor, and the voltage drop in the series diode D<sub>BAT</sub> of the hold-up circuit. These effects cause BAT to be less than the top-cell voltage measured by the cell amplifier.

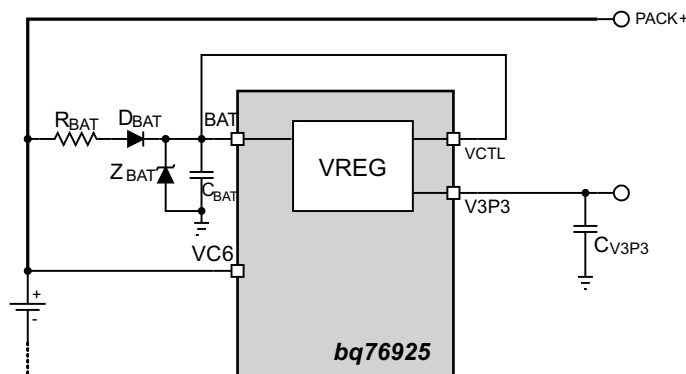

Figure 11. Sources of Voltage Drop Affecting the BAT Pin

## Feature Description (continued)

The top-cell amplifier (VC6 – VC5) is designed to measure an input voltage down to 1.4 V with a difference between the BAT and VC6 pin up to 1.2 V (that is, BAT can be 1.2 V lower than VC6). However, in applications with fewer than 6 cells, the upper-cell inputs are typically shorted to the top-cell input. For example, in a 5-cell application VC6 and VC5 would be shorted together and the (VC5 – VC4) amplifier would measure the top-cell voltage. The case is similar for 4-cell and 3-cell applications.

For these cases when using the (VC5 – VC4), (VC4 – VC3), or (VC3 – VC2) amplifier to measure the top cell, the difference between BAT and the top-cell amplifier must be less than 240 mV in order to measure cell voltages down to 1.4 V. Note that at higher-cell input voltages the top amplifier tolerates a greater difference. For example, in a 5-cell configuration (VC6 and VC5 tied together) the (VC5 – VC4) amplifier is able to measure down to a 1.7 V input with a 600-mV difference between VC5 and BAT.

Accordingly, in systems with fewer than 6 cells, it is important in system design to minimize  $R_{BAT}$  and to use a Schottky type diode for  $D_{BAT}$  with a low forward voltage. If it is not possible to reduce the drop at BAT to an acceptable level, then for 4-cell and 5-cell configurations, the (VC6 – VC5) amplifier may be used as the top cell amplifier as shown in [Table 1](#), which allows up to a 1.2 V difference between BAT and the top cell.

**Table 1. Alternate Connections for 4 and 5 Cells**

Configuration	Cell 5	Cell 4	Cell 3	Cell 2	Cell 1	Unused Cell Inputs
5-cell	VC6 – VC5	VC4 – VC3	VC3 – VC2	VC2 – VC1	VC1 – VC0	Short VC5 to VC4
4-cell		VC6 – VC5	VC3 – VC2	VC2 – VC1	VC1 – VC0	Short VC5 to VC4 to VC3

### 8.3.2.3 Current Monitoring

Current is measured by converting current to voltage through a sense resistor connected between SENSEN and SENSEP. A positive voltage at SENSEP with respect to SENSEN indicates a discharge current is flowing, and a negative voltage indicates a charge current. The small voltage developed across the sense resistor is amplified by gain  $G_{VIOUT}$  and output on the VIOUT pin for conversion by the Host ADC. The voltage on VIOUT is always positive and for zero current is set to 3/4 of the output range. The current sense amplifier is inverting; discharge current causes VIOUT to decrease and charge current causes VIOUT to increase. Therefore, the measurement range for discharge currents is 3 times the measurement range for charge currents.

The current-sense amplifier is preceded by a multiplexer that allows measurement of either the SENSEN or SENSEP input with respect to VSS. The Host selects the pin for measurement by writing the I\_AMP\_CAL bit in the CONFIG\_1 register. The Host then calculates the voltage across the sense resistor by subtracting the measured voltage at SENSEN from the measured voltage at SENSEP. If the SENSEN and VSS connections are such that charge and discharge currents do not flow through the connection between them; that is, there is no voltage drop between SENSEN and VSS due to the current being measured, then the measurement of the SENSEN voltage can be regarded as a calibration step and stored by the Host for use as a pseudo-constant in the  $V_{SENSE}$  calculation. The SENSEN voltage measurement would then only need updating when changing environmental conditions warrant.

The Host sets  $G_{VIOUT}$  by writing the I\_GAIN bit in the CONFIG\_1 register. The available gains of 4 and 8 enable operation with a variety of sense-resistor values over a broad range of pack currents. The gain may be changed at any time allowing for dynamic range and resolution adjustment. The input and output ranges of the amplifier are determined by the value of the REF\_SEL bit in the CONFIG\_2 register. These values are shown in [Table 2](#). Because the current amplifier is inverting, the Min column under Output Range corresponds to the Max column under Input Range. Likewise, the Max column under Output Range corresponds to the Min column under Input Range.

The actual current is calculated from the measured voltage (VIOUT) as follows. Note that  $V_{SENSE}$  is positive when discharge current is flowing. In keeping with battery pack conventions, the sign of  $I_{SENSE}$  is inverted so that discharge current is negative.

$$V_{SENSE} = \frac{-(VIOUT(SENSEP) - VIOUT(SENSEN))}{G_{VIOUT}}$$

$$I_{SENSE} = -\frac{V_{SENSE}}{R_{SENSE}} \quad (4)$$



**Table 2. Current Amplifier Configurations**

REF_SEL	I_GAIN	Gain	V <sub>IOUT</sub> (V) at I <sub>SENSE</sub> = 0 (typical)	Input Range <sup>(1)</sup> (mV)		Output Range <sup>(2)</sup> (V)		I <sub>SENSE</sub> Range (A) at R <sub>SENSE</sub> = 1 mΩ	I <sub>SENSE</sub> Resolution (mA)/10-bit ADC <sup>(3)</sup>
				Min	Max	Min	Max		
0	0	4	1.0	-62.5	187.5	0.25	1.25	-62.5 – 187.5	366
0	1	8	1.0	-14	91	0.27	1.11	-14 – 91	183
1	0	4	2.0	-125	375	0.5	2.5	-125 – 375	732
1	1	8	2.0	-62.5	187.5	0.5	2.5	-62.5 – 187.5	366

(1) SENSEN or SENSEP measured with respect to VSS.

(2) Output range assumes typical value of V<sub>IOUT</sub> at I<sub>SENSE</sub> = 0. For non-typical values, the output range will shift accordingly.

(3) Assumes 1 mΩ R<sub>SENSE</sub> and ADC reference voltage of 1.5 V and 3.0 V when REF\_SEL = 0 and 1, respectively.

### 8.3.2.4 Overcurrent Monitoring

The BQ76925 device also includes a comparator for monitoring the current-sense resistor and alerting the Host when the voltage across the sense resistor exceeds a selected threshold. The available thresholds range from 25 mV to 400 mV and are set by writing the I\_THRESH bits in the CONFIG\_1 register. Positive (discharge) or negative (charge) current may be monitored by setting the I\_COMP\_POL bit in the CONFIG\_1 register. By the choice of sense resistor and threshold, a variety of trip points are possible to support a wide range of applications.

The comparator result is driven through the open-drain ALERT output to signal the host when the threshold is exceeded. This feature can be used to wake up the Host on connection of a load or to alert the Host to a potential fault condition. The ALERT pin state is also available by reading the ALERT bit in the STATUS register.

### 8.3.2.5 Temperature Monitoring

To enable temperature measurements by the Host, the BQ76925 device provides the LDO regulator voltage on a separate output pin (VTB) for biasing an external thermistor network. In order to minimize power consumption, the Host may switch the VTB output on and off by writing to the VTB\_EN bit in the POWER\_CTL register. Note that if the LDO is back-fed by an external source, the VTB bias will be switched to the external source.

In a typical application, the thermistor network will consist of a resistor in series with an NTC thermistor, forming a resistor divider where the output is proportional to temperature. This output may be measured by the Host ADC to determine temperature.

#### 8.3.2.5.1 Internal Temperature Monitoring

The internal temperature (T<sub>INT</sub>) of the BQ76925 device can be measured by setting V<sub>COU</sub>\_SEL = '01' and CELL\_SEL = '110' in the CELL\_CTL register. In this configuration, a voltage proportional to temperature (V<sub>TEMP\_INT</sub>) is output on the V<sub>COU</sub> pin. This voltage is related to the internal temperature as follows:

$$V_{TEMP\_INT}(mV) = V_{TEMP\_INT}(T_{INT} = 25^{\circ}C) - T_{INT}(^{\circ}C) \times \Delta V_{TEMP\_INT} \quad (5)$$

### 8.3.3 Cell Balancing and Open Cell Detection

The BQ76925 device integrates cell-balancing FETs that are individually controlled by the Host. The balancing method is resistive bleed balancing, where the balancing current is set by the external cell input resistors. The maximum allowed balancing current is 50 mA per cell.

The Host may activate one or more cell balancing FETs by writing the BAL\_n bits in the BAL\_CTL register. To allow the greatest flexibility, the Host has complete control over the balancing FETs. However, in order to avoid exceeding the maximum cell input voltage, the BQ76925 will prevent two adjacent balancing FETs from being turned on simultaneously. If two adjacent bits in the balance control register are set to 1, neither balancing transistor will be turned on. The Host based balancing algorithm must also limit the power dissipation to the maximum ratings of the device.

In a normal system, closing a cell-balancing FET will cause 2 cell voltages to appear across one cell input. This fact can be utilized to detect a cell sense-line open condition, that is, a broken wire from the cell-sense point to the BQ76925 VC<sub>n</sub> input. Table 3 shows how this can be accomplished. Note that the normal cell-voltage measurements may represent a saturated or full-scale reading. However, these will normally be distinguishable from the open-cell measurement.

**Table 3. Open Cell Detection Method**

Kelvin input to test	Method 1				Method 2			
	Turn On	Measure	Result		Turn On	Measure	Result	
			Normal	Open			Normal	Open
VC0	BAL_1	CELL2	$CELL2 + 0.5 \times CELL1$	CELL2				
VC1	BAL_2	CELL3	$CELL3 + 0.5 \times CELL2$	CELL3				
VC2	BAL_3	CELL4	$CELL4 + 0.5 \times CELL3$	CELL4	BAL_2	CELL1	$CELL1 + 0.5 \times CELL2$	CELL1
VC3	BAL_4	CELL5	$CELL5 + 0.5 \times CELL4$	CELL5	BAL_3	CELL2	$CELL2 + 0.5 \times CELL3$	CELL2
VC4	BAL_5	CELL6	$CELL6 + 0.5 \times CELL5$	CELL6	BAL_4	CELL3	$CELL3 + 0.5 \times CELL4$	CELL3
VC5					BAL_5	CELL4	$CELL4 + 0.5 \times CELL5$	CELL4
VC6					BAL_6	CELL5	$CELL5 + 0.5 \times CELL6$	CELL5

**NOTE**

The cell amplifier headroom limits discussed above apply to the open-cell detection method because by virtue of closing a switch between 2 cell inputs, internal to the device this appears as an extreme cell imbalance. Therefore, when testing for an open on CELL2 by closing the CELL1 balancing FET, the CELL2 measurement will be less than the expected normal result due to gain loss caused by the imbalance. However, the CELL2 measurement will still increase under this condition so that a difference between open (no change) and normal (measured voltage increases) can be detected.

## 8.4 Device Functional Modes

### 8.4.1 Power Modes

#### 8.4.1.1 POWER ON RESET (POR)

When initially powering up the BQ76925 device, the voltage on the BAT pin must exceed  $V_{POR}$  (4.7-V maximum) before the device will turn on. Following this, the device will remain operational as long as the voltage on BAT remains above  $V_{SHUT}$  (3.6-V maximum). If the BAT voltage falls below  $V_{SHUT}$ , the device will shut down. Recovery from shutdown occurs when BAT rises back above the  $V_{POR}$  threshold and is equivalent to a POR. The  $V_{POR}$  threshold following a shutdown depends on the minimum level reached by BAT after crossing below  $V_{SHUT}$ . If BAT does not fall below approximately 1.4 V, a higher  $V_{POR}$  (7.5-V maximum) applies. This is illustrated in [Figure 12](#).

## Device Functional Modes (continued)

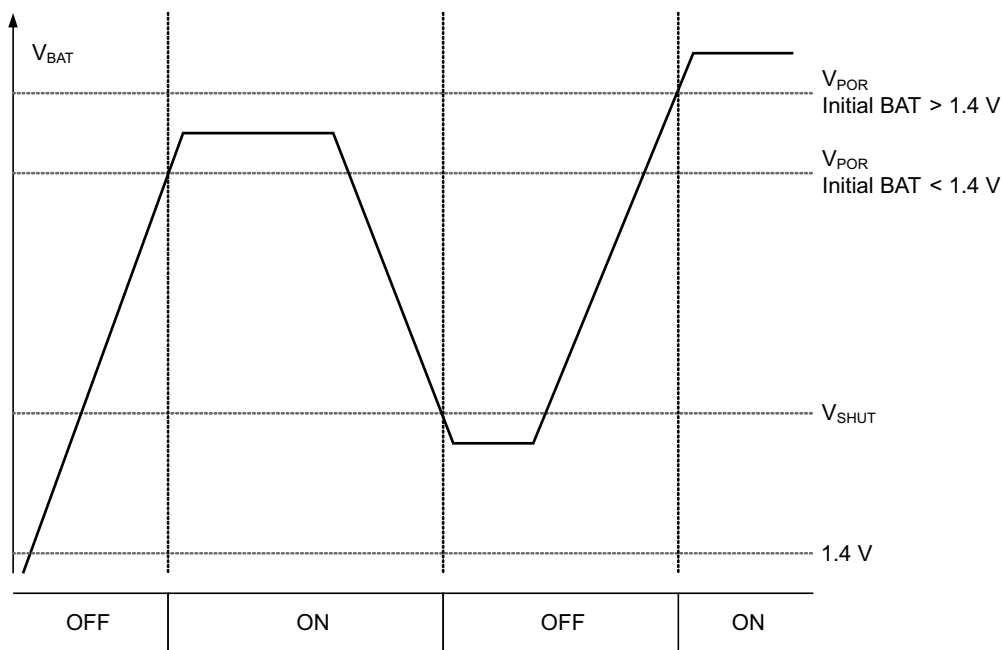

Figure 12. Power On State vs  $V_{BAT}$

Following a power on reset, all volatile registers assume their default state. Therefore, care must be taken that transients on the BAT pin during normal operation do not fall below  $V_{SHUT}$ . To avoid this condition in systems subject to extreme transients or brown-outs, a hold-up circuit such as the one shown in the functional diagram is recommended. When using a hold-up circuit, care must be taken to observe the BAT to VC6 maximum ratings.

### 8.4.1.2 STANDBY

Individual device functions such as cell translator, current amplifier, reference, and current comparator can be enabled and disabled under Host control by writing to the POWER\_CTL register. The STANDBY feature can be used to save power by disabling functions that are unused. In the minimum power standby mode, all device functions can be turned off leaving only the 3.3-V regulator active.

### 8.4.1.3 SLEEP

In addition to STANDBY, there is also a SLEEP mode. In SLEEP mode the Host orders the BQ76925 device to shutdown all internal circuitry and all functions including the LDO regulator. The device consumes a minimal amount of current ( $< 1.5 \mu\text{A}$ ) in SLEEP mode due only to leakage and powering of the wake-up detection circuitry.

SLEEP mode is entered by writing a '1' to the SLEEP bit in the POWER\_CTL register. Wake-up is achieved by pulling up the ALERT pin; however, the wake-up circuitry is not armed until the voltage at V3P3 drops to approximately 0 V. To facilitate the discharge of V3P3, an internal 3-k $\Omega$  pulldown resistor is connected from V3P3 to VSS during the time that sleep mode is active. Once V3P3 is discharged, the BQ76925 may be awakened by pulling the ALERT pin above  $V_{WAKE}$  (2-V maximum).

The SLEEP\_DIS bit in the POWER\_CTL register acts as an override to the SLEEP function. When SLEEP\_DIS is set to '1', writing the SLEEP bit has no effect (that is, SLEEP mode cannot be entered). If SLEEP\_DIS is set after SLEEP mode has been entered, the device will immediately exit SLEEP mode. This scenario can arise if SLEEP\_DIS is set after SLEEP is set, but before V3P3 has discharged below a valid operating voltage. This scenario can also occur if the V3P3 pin is held up by external circuitry and not allowed to fully discharge.

If the overcurrent alert function is not used, the ALERT pin can function as a dedicated wake-up pin. Otherwise, the ALERT pin will normally be pulled up to the LDO voltage, so care must be taken in the system design so that the wake-up signal does not interfere with proper operation of the regulator.

## 8.5 Programming

### 8.5.1 Host Interface

The Host communicates with the AFE through an I<sup>2</sup>C interface. A CRC byte may optionally be used to ensure robust operation. The CRC is calculated over all bytes in the message according to the polynomial  $x^8 + x^2 + x + 1$ .

#### 8.5.1.1 I<sup>2</sup>C Addressing

In order to reduce communications overhead, the addressing scheme for the I<sup>2</sup>C interface combines the slave device address and device register addresses into a single 7-bit address as shown below.

$$\text{ADDRESS}[6:0] = (\text{I2C\_GROUP\_ADDR}[3:0] \ll 3) + \text{REG\_ADDR}[4:0]$$

The I2C\_GROUP\_ADDR is a 4-bit value stored in the EEPROM. REG\_ADDR is the 5-bit register address being accessed, and can range from 0x00 – 0x1F. The factory programmed value of the group address is '0100'. Contact TI if an alternative group address is required.

For the default I2C\_GROUP\_ADDR, the combined address can be formed as shown in [Table 4](#).

**Table 4. Combined I<sup>2</sup>C Address for Default Group Address**

ADDRESS[6:0]		
6	5	4:0
0	1	Register address

#### 8.5.1.2 Bus Write Command to BQ76925

The Host writes to the registers of the BQ76925 device as shown in [Figure 13](#). The BQ76925 acknowledges each received byte by pulling the SDA line low during the acknowledge period.

The Host may optionally send a CRC after the Data byte as shown. The CRC for write commands is enabled by writing the CRC\_EN bit in the CONFIG\_2 register. If the CRC is not used, then the Host generates the Stop condition immediately after the BQ76925 acknowledges receipt of the Data byte.

When the CRC is disabled, the BQ76925 device will act on the command on the first rising edge of SCL following the ACK of the Data byte. This occurs as part of the normal bus setup prior to a Stop. If a CRC byte is sent while the CRC is disabled, the first rising edge of the SCL following the ACK will be the clocking of the first bit of the CRC. The BQ76925 device does not distinguish these two cases. In both cases, the command will complete normally, and in the latter case the CRC will be ignored.

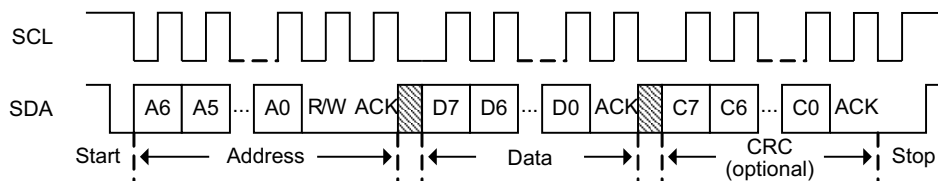
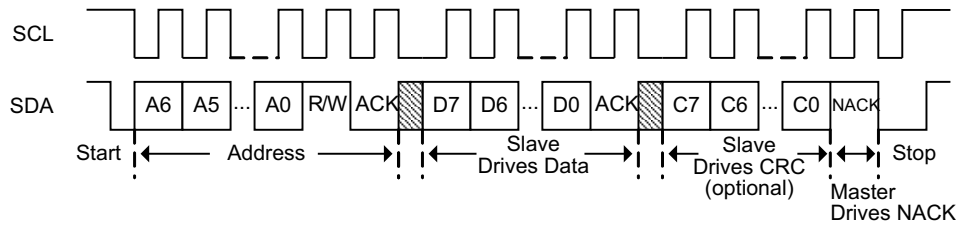

**Figure 13. I<sup>2</sup>C Write Command**

#### 8.5.1.3 Bus Read Command from BQ76925 Device

The Host reads from the registers of the BQ76925 device as shown in [Figure 14](#). This protocol is similar to the write protocol, except that the slave now drives data back to the Host. The BQ76925 device acknowledges each received byte by pulling the SDA line low during the acknowledge period. When the BQ76925 device sends data back to the Host, the Host drives the acknowledge.

The Host may optionally request a CRC byte following the Data byte as shown. The CRC for read commands is always enabled, but not required. If the CRC is not used, then the Host simply NACK's the Data byte and then generates the Stop condition.



**Figure 14. I<sup>2</sup>C Read Command**

## 8.6 Register Maps

Address	Name	Access	D7	D6	D5	D4	D3	D2	D1	D0
0x00	STATUS	R/W						ALERT	CRC_ERR	POR
0x01	CELL_CTL	R/W			VCOUT_SEL			CELL_SEL		
0x02	BAL_CTL	R/W			BAL_6	BAL_5	BAL_4	BAL_3	BAL_2	BAL_1
0x03	CONFIG_1	R/W	I_THRESH				I_COMP_POL	I_AMP_CAL	I_GAIN	
0x04	CONFIG_2	R/W	CRC_EN							REF_SEL
0x05	POWER_CTL	R/W	SLEEP	SLEEP_DIS		I_COMP_EN	I_AMP_EN	VC_AMP_EN	VTB_EN	REF_EN
0x06	Reserved	R/W								
0x07	CHIP_ID	RO	CHIP_ID							
0x08 – 0x0F	Reserved	R/W								
0x10	VREF_CAL	EEPROM	VREF_OFFSET_CORR				VREF_GAIN_CORR			
0x11	VC1_CAL	EEPROM	VC1_OFFSET_CORR				VC1_GAIN_CORR			
0x12	VC2_CAL	EEPROM	VC2_OFFSET_CORR				VC2_GAIN_CORR			
0x13	VC3_CAL	EEPROM	VC3_OFFSET_CORR				VC3_GAIN_CORR			
0x14	VC4_CAL	EEPROM	VC4_OFFSET_CORR				VC4_GAIN_CORR			
0x15	VC5_CAL	EEPROM	VC5_OFFSET_CORR				VC5_GAIN_CORR			
0x16	VC6_CAL	EEPROM	VC6_OFFSET_CORR				VC6_GAIN_CORR			
0x17	VC_CAL_EXT_1	EEPROM	VC1_OC_4	VC1_GC_4	VC2_OC_4	VC2_GC_4				
0x18	VC_CAL_EXT_2	EEPROM	VC3_OC_4	VC3_GC_4	VC4_OC_4	VC4_GC_4	VC5_OC_4	VC5_GC_4	VC6_OC_4	VC6_GC_4
0x10 – 0x1A	Reserved	EEPROM								
0x1B	VREF_CAL_EXT	EEPROM					1	VREF_OC_5	VREF_OC_4	VREF_GC_4
0x1C – 0x1F	Reserved	EEPROM								

### 8.6.1 Register Descriptions

**Table 5. STATUS Register**

Address	Name	Type	D7	D6	D5	D4	D3	D2	D1	D0
0x00	STATUS	R/W						ALERT	CRC_ERR	POR
Defaults:			0	0	0	0	0	0	0	1

ALERT: Over-current alert. Reflects state of the over-current comparator. ‘1’ = over-current.

CRC\_ERR: CRC error status. Updated on every I<sup>2</sup>C write packet when CRC\_EN = ‘1’. ‘1’ = CRC error.

POR: Power on reset flag. Set on each power-up and wake-up from sleep. May be cleared by writing with ‘0’.

**Table 6. CELL\_CTL**

Address	Name	Type	D7 <sup>(1)</sup>	D6	D5	D4	D3	D2	D1	D0
0x01	CELL_CTL	R/W			VCOUT_SEL			CELL_SEL		
Defaults:			0	0	0	0	0	0		

(1) This bit must be kept = 0

VCOUT\_SEL: VCOUT MUX select. Selects the VCOUT pin function as follows.

**Table 7. VCOUT Pin Functions**

VCOUT_SEL	VCOUT
0 0	VSS
0 1	VCn (n determined by CELL_SEL)
1 0	VREF × 0.5
1 1	VREF × 0.85

CELL\_SEL: Cell select. Selects the VCn input for output on VCOUT when VCOUT\_SEL = ‘01’.

**Table 8. Cell Selection**

VCOUT_SEL	CELL_SEL	VCOUT
0 1	0 0 0	VC1
0 1	0 0 1	VC2
0 1	0 1 0	VC3
0 1	0 1 1	VC4
0 1	1 0 0	VC5
0 1	1 0 1	VC6
0 1	1 1 0	V <sub>TEMP,INT</sub>
0 1	1 1 1	Hi-Z

**Table 9. BAL\_CTL**

Address	Name	Type	D7	D6	D5	D4	D3	D2	D1	D0
0x02	BAL_CTL	R/W			BAL_6	BAL_5	BAL_4	BAL_3	BAL_2	BAL_1
Defaults:			0	0	0	0	0	0	0	0

BAL\_n: Balance control for cell n. When set, turns on balancing transistor for cell n. Setting of two adjacent balance controls is not permitted. If two adjacent balance controls are set, neither cell balancing transistor will be turned on. However, the BAL\_n bits will retain their values.

**Table 10. CONFIG\_1**

Address	Name	Type	D7	D6	D5	D4	D3	D2	D1	D0
0x03	CONFIG_1	R/W	I_THRESH			I_COMP_POL	I_AMP_CAL			I_GAIN
Defaults:			0			0	0	0	0	0

I\_THRESH: Current comparator threshold. Sets the threshold of the current comparator as follows:

**Table 11. Current Comparator Threshold**

I_THRESH	Comparator Threshold
0x0	25 mV
0x1	50 mV
0x2	75 mV
0x3	100 mV
0x4	125 mV
0x5	150 mV
0x6	175 mV
0x7	200 mV
0x8	225 mV
0x9	250 mV
0xA	275 mV
0xB	300 mV
0xC	325 mV
0xD	350 mV
0xE	375 mV
0xF	400 mV

I\_COMP\_POL: Current comparator polarity select. When '0', trips on discharge current (SENSEP > SENSEN). When '1', trips on charge current (SENSEP < SENSEN).

I\_AMP\_CAL: Current amplifier calibration. When '0', current amplifier reports SENSEN with respect to VSS. When '1', current amplifier reports SENSEP with respect to VSS. This bit can be used for offset cancellation as described under OPERATIONAL OVERVIEW.

I\_GAIN: Current amplifier gain. Sets the nominal gain of the current amplifier as follows.

**Table 12. Nominal Gain of the Current Amplifier**

I_GAIN	Current amp gain
0	4
1	8

**Table 13. CONFIG\_2**

Address	Name	Type	D7	D6	D5	D4	D3	D2	D1	D0
0x04	CONFIG_2	R/W	CRC_EN							REF_SEL
Defaults:			0	0	0	0	0	0	0	0

CRC\_EN: CRC enable. Enables CRC comparison on write. When '1', CRC is enabled. CRC on read is always enabled but is optional for Host.

REF\_SEL: Reference voltage selection. Sets reference voltage output on VREF pin, cell-voltage amplifier gain and VIOUT output range.

**Table 14. Reference Voltage Selection**

REF_SEL	VREF (V)	VCOUT Gain	VIOUT Output Range (V)
0	1.5	0.3	0.25 – 1.25
1	3.0	0.6	0.5 – 2.5

**Table 15. POWER\_CTL**

Address	Name	Type	D7	D6	D5	D4	D3	D2	D1	D0
0x05	POWER_CTL	R/W	SLEEP	SLEEP_DIS		I_COMP_EN	I_AMP_EN	VC_AMP_EN	VTB_EN	REF_EN
Defaults:			0	0	0	0	0	0	0	0

SLEEP: Sleep control. Set to '1' to put device to sleep

SLEEP\_DIS: Sleep mode disable. When '1', disables the sleep mode.

I\_COMP\_EN: Current comparator enable. When '1', comparator is enabled. Disable to save power.

I\_AMP\_EN: Current amplifier enable. When '1', current amplifier is enabled. Disable to save power.

VC\_AMP\_EN: Cell amplifier enable. When '1', cell amplifier is enabled. Disable to save power.

VTB\_EN: Thermistor bias enable. When '1', the VTB pin is internally switched to the V3P3 voltage.

REF\_EN: Voltage reference enable. When '1', the 1.5 / 3.0 V reference is enabled. Disable to save power

**Table 16. CHIP\_ID**

Address	Name	Type	D7	D6	D5	D4	D3	D2	D1	D0
0x07	CHIP_ID	RO	CHIP_ID							
Defaults:			0x10							

CHIP\_ID: Silicon version identifier.



**Table 17. VREF\_CAL**

Address	Name	Type	D7	D6	D5	D4	D3	D2	D1	D0
0x10	VREF_CAL	EEPROM	VREF_OFFSET_CORR				VREF_GAIN_CORR			

**VREF\_OFFSET\_CORR:** Lower 4 bits of offset-correction factor for reference output. The complete offset-correction factor is obtained by concatenating this value with the the two most significant bits VREF\_OC\_5 and VREF\_OC\_4, which are stored in the VREF\_CAL\_EXT register. The final value is a 6-bit signed 2's complement number in the range –32 to +31 with a value of 1 mV per LSB. See description of usage in [Detailed Description](#).

**VREF\_GAIN\_CORR:** Lower 4 bits of gain correction factor for reference output. The complete gain correction factor is obtained by concatenating this value with the most significant bit VREF\_GC\_4, which is stored in the VREF\_CAL\_EXT register. The final value is a 5-bit signed 2's complement number in the range –16 to +15 with a value of 0.1% per lsb. See description of usage in [Detailed Description](#).

**Table 18. VC1\_CAL**

Address	Name	Type	D7	D6	D5	D4	D3	D2	D1	D0
0x11	VC1_CAL	EEPROM	VC1_OFFSET_CORR				VC1_GAIN_CORR			

**VC1\_OFFSET\_CORR:** Lower 4 bits of offset correction factor for cell 1 translation. The complete offset correction factor is obtained by concatenating this value with the most significant bit VC1\_OC\_4, which is stored in the VC\_CAL\_EXT\_1 register. The final value is a 5-bit signed 2's complement number in the range –16 to +15 with a value of 1 mV per lsb. See description of usage in [Detailed Description](#).

**VC1\_GAIN\_CORR:** Lower 4 bits of gain correction factor for cell 1 translation. The complete gain correction factor is obtained by concatenating this value with the most significant bit VC1\_GC\_4, which is stored in the VC\_CAL\_EXT\_1 register. The final value is a 5-bit signed 2's complement number in the range –16 to +15 with a value of 0.1% per lsb. See description of usage in [Detailed Description](#).

**Table 19. VC2\_CAL**

Address	Name	Type	D7	D6	D5	D4	D3	D2	D1	D0
0x12	VC2_CAL	EEPROM	VC2_OFFSET_CORR				VC2_GAIN_CORR			

**VC2\_OFFSET\_CORR:** Lower 4 bits of offset correction factor for cell 2 translation. The complete offset correction factor is obtained by concatenating this value with the most significant bit VC2\_OC\_4, which is stored in the VC\_CAL\_EXT\_1 register. The final value is a 5-bit signed 2's complement number in the range –16 to +15 with a value of 1 mV per LSB. See description of usage in [Detailed Description](#).

**VC2\_GAIN\_CORR:** Lower 4 bits of gain correction factor for cell 2 translation. The complete gain correction factor is obtained by concatenating this value with the most significant bit VC2\_GC\_4, which is stored in the VC\_CAL\_EXT\_1 register. The final value is a 5-bit signed 2's complement number in the range –16 to +15 with a value of 0.1% per LSB. See description of usage in [Detailed Description](#).

**Table 20. VC3\_CAL**

Address	Name	Type	D7	D6	D5	D4	D3	D2	D1	D0
0x13	VC3_CAL	EEPROM	VC3_OFFSET_CORR				VC3_GAIN_CORR			

**VC3\_OFFSET\_CORR:** Lower 4 bits of offset correction factor for cell 3 translation. The complete offset correction factor is obtained by concatenating this value with the most significant bit VC3\_OC\_4, which is stored in the VC\_CAL\_EXT\_2 register. The final value is a 5-bit signed 2's complement number in the range –16 to +15 with a value of 1 mV per lsb. See description of usage in [Detailed Description](#).

**VC3\_GAIN\_CORR:** Lower 4 bits of gain correction factor for cell 3 translation. The complete gain correction factor is obtained by concatenating this value with the most significant bit VC3\_GC\_4, which is stored in the VC\_CAL\_EXT\_2 register. The final value is a 5-bit signed 2's complement number in the range –16 to +15 with a value of 0.1% per lsb. See description of usage in [Detailed Description](#).

**Table 21. VC4\_CAL**

Address	Name	Type	D7	D6	D5	D4	D3	D2	D1	D0
0x14	VC4_CAL	EEPROM	VC4_OFFSET_CORR				VC4_GAIN_CORR			

**VC4\_OFFSET\_CORR:** Lower 4 bits of offset correction factor for cell 4 translation. The complete offset correction factor is obtained by concatenating this value with the most significant bit VC4\_OC\_4, which is stored in the VC\_CAL\_EXT\_2 register. The final value is a 5-bit signed 2's complement number in the range –16 to +15 with a value of 1 mV per lsb. See description of usage in [Detailed Description](#).

**VC4\_GAIN\_CORR:** Lower 4 bits of gain correction factor for cell 4 translation. The complete gain correction factor is obtained by concatenating this value with the most significant bit VC4\_GC\_4, which is stored in the VC\_CAL\_EXT\_2 register. The final value is a 5-bit signed 2's complement number in the range –16 to +15 with a value of 0.1% per lsb. See description of usage in [Detailed Description](#).

**Table 22. VC5\_CAL**

Address	Name	Type	D7	D6	D5	D4	D3	D2	D1	D0
0x15	VC5_CAL	EEPROM	VC5_OFFSET_CORR				VC5_GAIN_CORR			

**VC5\_OFFSET\_CORR:** Lower 4 bits of offset correction factor for cell 5 translation. The complete offset correction factor is obtained by concatenating this value with the most significant bit VC5\_OC\_4, which is stored in the VC\_CAL\_EXT\_2 register. The final value is a 5-bit signed 2's complement number in the range –16 to +15 with a value of 1 mV per LSB. See description of usage in [Detailed Description](#).

**VC5\_GAIN\_CORR:** Lower 4 bits of gain correction factor for cell 5 translation. The complete gain correction factor is obtained by concatenating this value with the most significant bit VC5\_GC\_4, which is stored in the VC\_CAL\_EXT\_2 register. The final value is a 5-bit signed 2's complement number in the range –16 to +15 with a value of 0.1% per LSB. See description of usage in [Detailed Description](#).

**Table 23. VC6\_CAL**

Address	Name	Type	D7	D6	D5	D4	D3	D2	D1	D0
0x16	VC6_CAL	EEPROM	VC6_OFFSET_CORR				VC6_GAIN_CORR			

**VC6\_OFFSET\_CORR:** Lower 4 bits of offset correction factor for cell 6 translation. The complete offset correction factor is obtained by concatenating this value with the most significant bit VC6\_OC\_4, which is stored in the VC\_CAL\_EXT\_2 register. The final value is a 5-bit signed 2's complement number in the range –16 to +15 with a value of 1 mV per LSB. See description of usage in [Detailed Description](#).

**VC6\_GAIN\_CORR:** Lower 4 bits of gain correction factor for cell 6 translation. The complete gain correction factor is obtained by concatenating this value with the most significant bit VC6\_GC\_4, which is stored in the VC\_CAL\_EXT\_2 register. The final value is a 5-bit signed 2's complement number in the range –16 to +15 with a value of 0.1% per LSB. See description of usage in [Detailed Description](#).

**Table 24. VC\_CAL\_EXT\_1**

Address	Name	Type	D7	D6	D5	D4	D3	D2	D1	D0
0x17	VC_CAL_EXT_1	EEPROM	VC1_OC_4	VC1_GC_4	VC2_OC_4	VC2_GC_4				

**VC1\_OC\_4:** Most significant bit of offset correction factor for cell 1 translation. See [Table 18](#) register description for details.

**VC1\_GC\_4:** Most significant bit of gain correction factor for cell 1 translation. See [Table 18](#) register description for details.

**VC2\_OC\_4:** Most significant bit of offset correction factor for cell 2 translation. See [Table 19](#) register description for details.

**VC2\_GC\_4:** Most significant bit of gain correction factor for cell 2 translation. See [Table 19](#) register description for details.

**Table 25. VC\_CAL\_EXT\_2**

Address	Name	Type	D7	D6	D5	D4	D3	D2	D1	D0
0x18	VC_CAL_EXT_2	EEPROM	VC3_OC_4	VC3_GC_4	VC4_OC_4	VC4_GC_4	VC5_OC_4	VC5_GC_4	VC6_OC_4	VC6_GC4

VC3\_OC\_4: Most significant bit of offset correction factor for cell 3 translation. See [Table 20](#) register description for details.

VC3\_GC\_4: Most significant bit of gain correction factor for cell 3 translation. See [Table 20](#) register description for details.

VC4\_OC\_4: Most significant bit of offset correction factor for cell 4 translation. See [Table 21](#) register description for details.

VC4\_GC\_4: Most significant bit of gain correction factor for cell 4 translation. See [Table 21](#) register description for details.

VC5\_OC\_4: Most significant bit of offset correction factor for cell 5 translation. See [Table 22](#) register description for details.

VC5\_GC\_4: Most significant bit of gain correction factor for cell 5 translation. See [Table 22](#) register description for details.

VC6\_OC\_4: Most significant bit of offset correction factor for cell 6 translation. See [Table 23](#) register description for details.

VC6\_GC\_4: Most significant bit of gain correction factor for cell 6 translation. See [Table 23](#) register description for details.

**Table 26. VREF\_CAL\_EXT**

Address	Name	Type	D7	D6	D5	D4	D3	D2	D1	D0
0x1B	VREF_CAL_EXT	EEPROM					1	VREF_OC_5	VREF_OC_4	VREF_GC4

VREF\_OC\_5: Most significant bit of offset correction factor for reference output. See [Table 17](#) register description for details.

VREF\_OC\_4: Next most significant bit of offset correction factor for reference output. See [Table 17](#) register description for details.

VREF\_GC\_4: Most significant bit of gain correction factor for reference output. See [Table 17](#) register description for details.

## 9 Application and Implementation

### NOTE

Information in the following applications sections is not part of the TI component specification, and TI does not warrant its accuracy or completeness. TI's customers are responsible for determining suitability of components for their purposes. Customers should validate and test their design implementation to confirm system functionality.

### 9.1 Application Information

The BQ76925 device is a host-controlled analog front end (AFE), providing the individual cell voltages, pack current, and temperature to the host system. The host controller may use this information to complete the pack monitoring, balancing, and protection functions for the 3-series to 6-series cell Li-ion/Li-Polymer battery.

The section below highlights several recommended implementations when using this device. A detailed BQ76925 Application report, [SLUA619](#), together with an example implementation report using BQ76925 and MSP430G2xx2, [SLUA707](#), are available at [www.ti.com](http://www.ti.com).

#### 9.1.1 Recommended System Implementation

##### 9.1.1.1 Voltage, Current, and Temperature Outputs

The BQ76925 device provides voltage, current, and temperature outputs in analog form. A microcontroller (MCU) with an analog-to-digital converter (ADC) is required to complete the measurement system. A minimum of three input-ADC channels of the MCU are required to measure cell voltages, current, and temperature output. The BQ76925 device can supply an external reference for the MCU ADC reference. Compare the internal reference voltage specification of the MCU to determine if using the AFE reference would improve the measurement accuracy.

##### 9.1.1.2 Power Management

The BQ76925 device can disable various functions for power management. Refer to the POWER\_CTL registers in this document for detailed descriptions. Additionally, the MCU can put the BQ76925 device into SHUTDOWN mode by writing to the [SLEEP] bit in the POWER\_CTL register. The wake up circuit does not activate until the V3P3 is completing discharge to 0 V. Once the wake up circuit is activated, pulling the ALERT pin high can wake up the device. This means, once the SLEEP command is sent, the BQ76925 device remains in SHUTDOWN mode and cannot wake up if V3P3 is > 0 V.

##### 9.1.1.3 Low Dropout (LDO) Regulator

When the LDO load current is higher than 4 mA, the LDO must be used with an external pass transistor. In this configuration, a high-gain bypass device is recommended. ZXT25040DFH and IRLML9303 are example transistors. A Z1 diode is recommended to protect the gate-source or base emitter of the bypass transistor.

Adding the  $R_{V3P3}$  and  $C_{V3P3-2}$  filter helps to isolate the load from the V3P3 transient caused by the load and the transients on BAT.

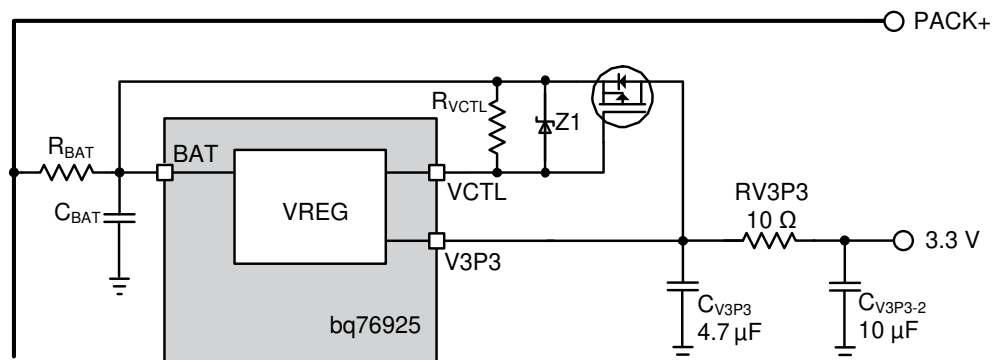

**Figure 15. LDO Regulator**

## Application Information (continued)

### 9.1.1.4 Input Filters

TI recommends to use input filters for BAT, VCx, and SENSEN/P pins to protect the BQ76925 device from large transients caused by switching of the battery load.

Additionally, the filter on BAT also avoids unintentional reset of the AFE when the battery voltage suddenly drops. To further avoid an unwanted reset, a hold-up circuit using a blocking diode can be added in series with the input filter. A zener diode clamp may be added in parallel with the filter capacitor to prevent the repeated peak transients that pump up the filter capacitor beyond the device absolute maximum rating.

### 9.1.1.5 Output Filters

Output capacitors are used on V3P3, VREF, VCOU, and VIOU for stability. These capacitors also function as bypass capacitors in response to the MCU internal switching and ADC operation. Additional filtering may be added to these output pins to smooth out noisy signals prior to ADC conversion. For the V3P3 case, an additional filter helps reduce the transient on the power input connected to the BQ76925 device's V3P3 pin.

### 9.1.2 Cell Balancing

The BQ76925 device integrates cell balancing FETs that are controlled individually by the host. The device does not automatically duty cycle the balancing FETs such that cell voltage measurement for protection detection is taken when balancing is off. The host MCU is responsible for such management. Otherwise, the MCU is free to turn on the voltage measurement during cell balancing, which enables the open-cell detection method described in this document. However, the BQ76925 device does prevent two adjacent balancing FETs from being turned on simultaneously. If such a condition occurs, both adjacent transistors will remain off.

## 9.2 Typical Application

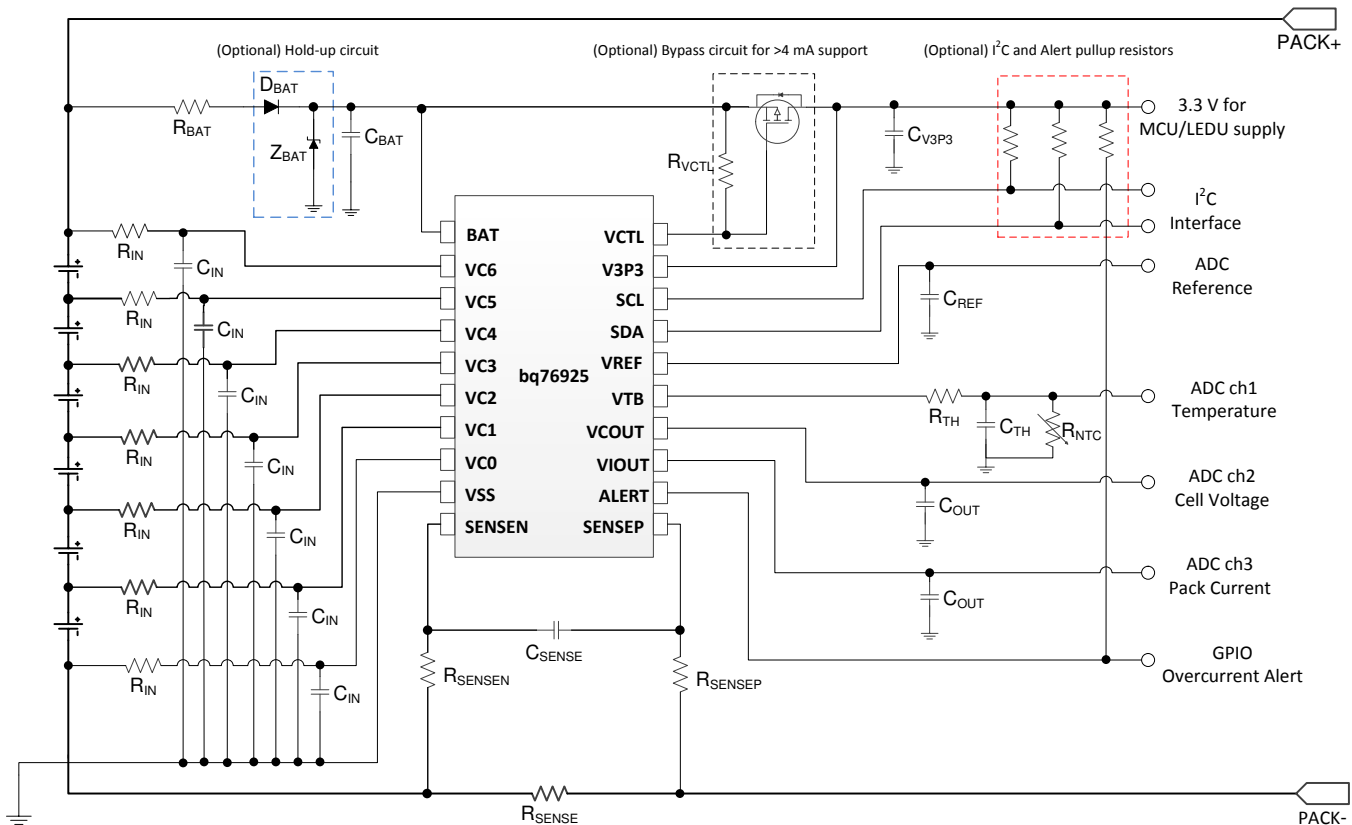

Figure 16. Typical Schematic

## Typical Application (continued)

### 9.2.1 Design Requirements

For this design example, use the parameters listed in [Table 27](#).

**Table 27. Design Parameters**

PARAMETER		MIN	TYP	MAX	UNIT
R <sub>BAT</sub>	BAT filter resistance		100		Ω
C <sub>BAT</sub>	BAT filter capacitance		10		μF
R <sub>IN</sub>	External cell input resistance		<sup>(1)</sup> 100		Ω
C <sub>IN</sub>	External cell input capacitance	0.1	1	10	μF
R <sub>SENSEIN</sub> R <sub>SENSEINP</sub>	Current sense input filter resistance		1K		Ω
C <sub>SENSE</sub>	Current sense input filter capacitance		0.1		μF
R <sub>VCTL</sub>	VCTL pullup resistance	Without external bypass transistor		0	Ω
		With external bypass transistor		200K	
C <sub>V3P3</sub>	V3P3 output capacitance	Without external bypass transistor		4.7	μF
		With external bypass transistor		1.0	
C <sub>REF</sub>	VREF output capacitance	1.0			μF
C <sub>OUT</sub>	ADC channel output capacitance	VCOUT		0.1	μF
		VIOUT		470	2000

(1)  $R_{IN,MIN} = 0.5 \times (VC_{n,MAX} / 50 \text{ mA})$  if cell balancing used so that maximum recommended cell balancing current is not exceeded.

### 9.2.2 Detailed Design Procedure

The following is the detailed design procedure.

1. Select a proper MCU to complete the battery management solution. Refer to the BQ76925 Application report, [SLUA619](#) on MCU requirement.
2. Based on the system design, determine if an alternative cell connection for 4-series and 5-series battery pack is needed. Refer to the “Cell Amplifier Headroom Under BAT Voltage Drop” section of this document.
3. Determine if a hold-up circuit for BAT and/or an external bypass transistor is needed based on the system design. Follow the reference schematic to complete the circuit design.
4. An example circuit design and MCU code implementation is documented in [SLUA707](#) using BQ76925 and MSP430G2xx2.

9.2.3 Application Curves

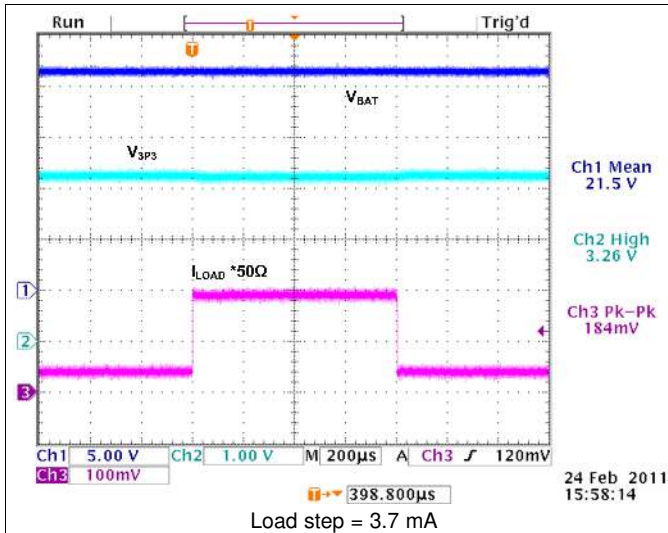

Figure 17. Voltage Regulator With Internal FET

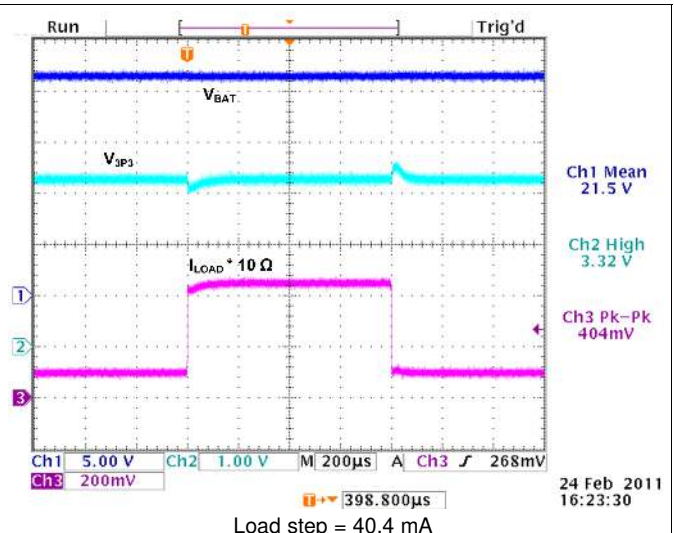

Figure 18. Voltage Regulator With External FET

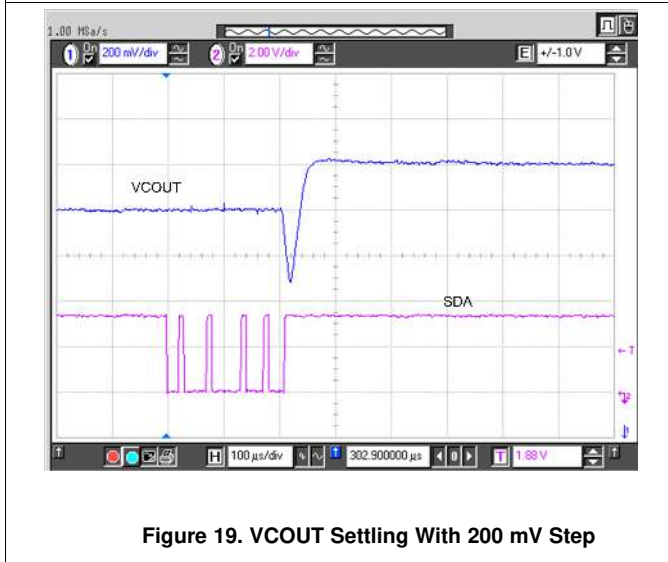

Figure 19. VOUT Settling With 200 mV Step

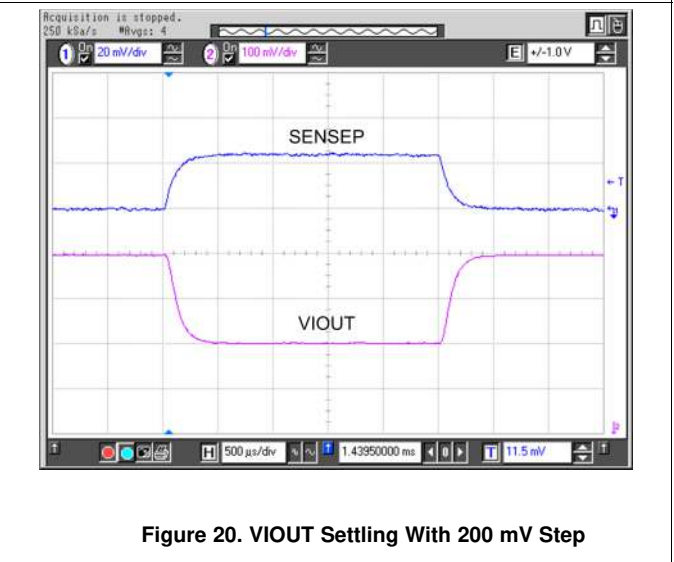

Figure 20. VIOUT Settling With 200 mV Step

## 10 Power Supply Recommendations

The maximum operating voltage on the BAT is 26.4 V. In some cases, a peak transient can be more than twice the battery's DC voltage. Ensure the device does not go beyond its absolute maximum rating.

## 11 Layout

### 11.1 Layout Guidelines

1. Place input filters for BAT, VCx, and SENSEN/P close to the device
2. Place output capacitors on V3P3, VREF, VCOOUT, and VIOUT close to the device
3. Please output filters (if any) close to the target device (for example, the MCU ADC input ports)
4. Isolate high-current and low-current groundings. The AFE, filter capacitors, and MCU grounds should connect to the low-current ground plane of the PCB.

### 11.2 Layout Example

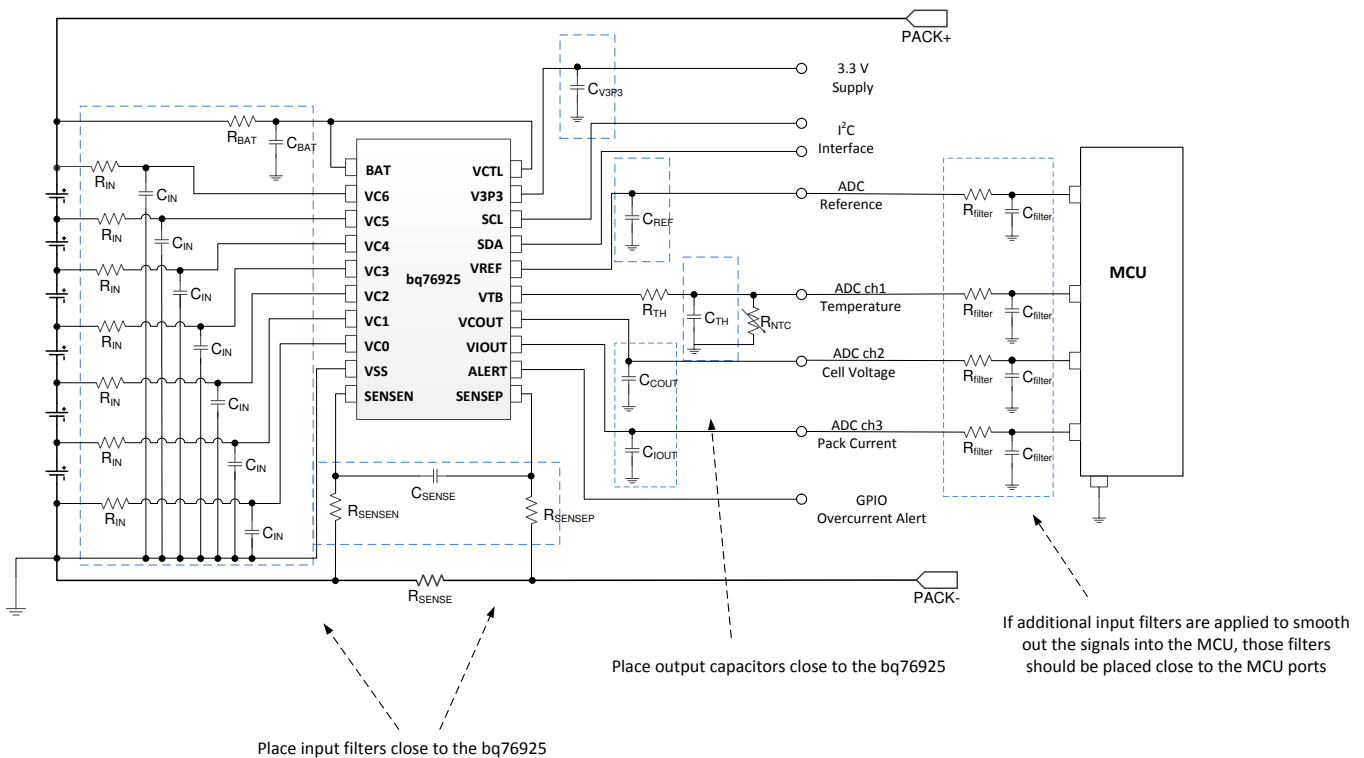

**Figure 21. Filters and Bypass Capacitors Placement**



Layout Example (continued)

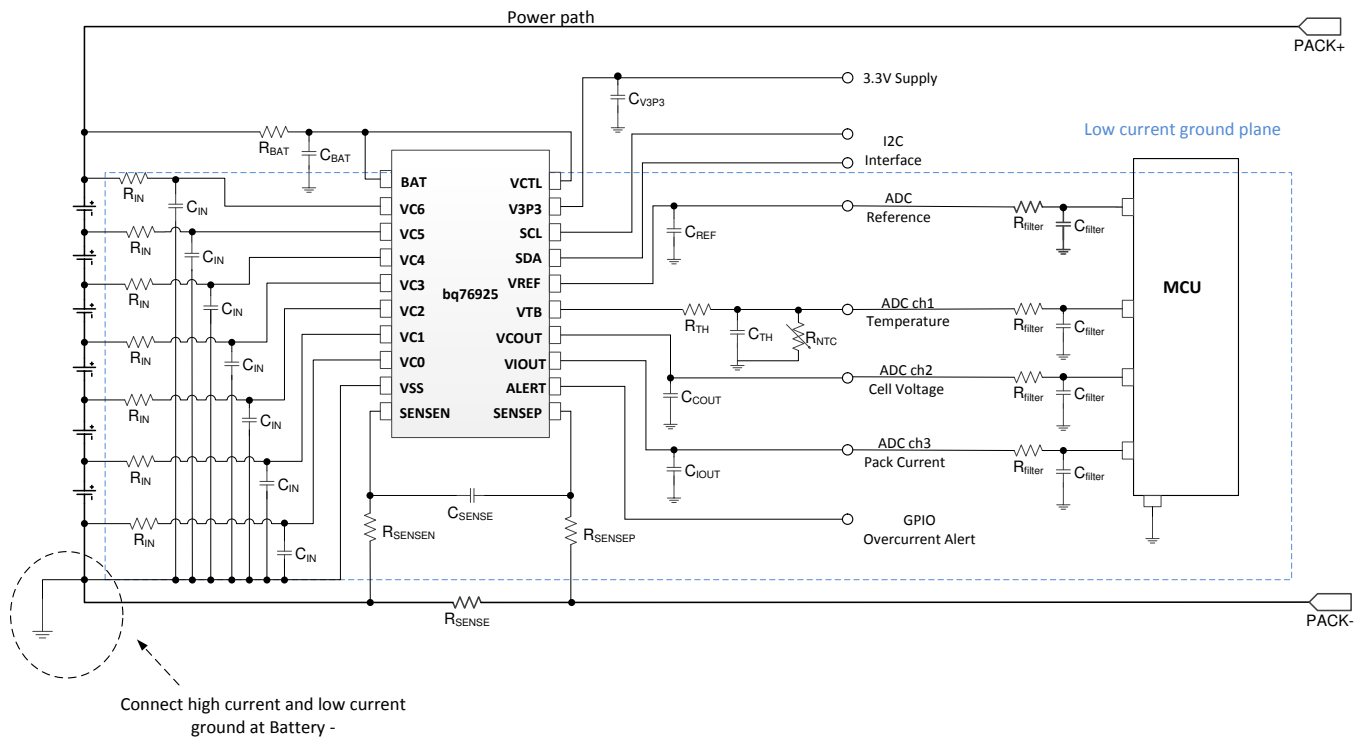

Figure 22. Separate High-Current and Low-Current Grounds

## 12 Device and Documentation Support

### 12.1 Documentation Support

#### 12.1.1 Related Documentation

- [Semiconductor and IC Package Thermal Metrics](#), SPRA953
- [Getting Started with the BQ76925](#), SLUA619
- [3 to 6 Cells Battery-Management System Based On BQ76925 + MSP430G2xx2](#), SLUA707

### 12.2 Receiving Notification of Documentation Updates

To receive notification of documentation updates, navigate to the device product folder on ti.com. In the upper right corner, click on *Alert me* to register and receive a weekly digest of any product information that has changed. For change details, review the revision history included in any revised document.

### 12.3 Support Resources

TI E2E™ [support forums](#) are an engineer's go-to source for fast, verified answers and design help — straight from the experts. Search existing answers or ask your own question to get the quick design help you need.

Linked content is provided "AS IS" by the respective contributors. They do not constitute TI specifications and do not necessarily reflect TI's views; see TI's [Terms of Use](#).

### 12.4 Trademarks

E2E is a trademark of Texas Instruments.  
All other trademarks are the property of their respective owners.

### 12.5 Electrostatic Discharge Caution



These devices have limited built-in ESD protection. The leads should be shorted together or the device placed in conductive foam during storage or handling to prevent electrostatic damage to the MOS gates.

### 12.6 Glossary

[SLYZ022](#) — *TI Glossary*.

This glossary lists and explains terms, acronyms, and definitions.

## 13 Mechanical, Packaging, and Orderable Information

The following pages include mechanical, packaging, and orderable information. This information is the most current data available for the designated devices. This data is subject to change without notice and revision of this document. For browser-based versions of this data sheet, refer to the left-hand navigation.

## PACKAGING INFORMATION

Orderable Device	Status (1)	Package Type	Package Drawing	Pins	Package Qty	Eco Plan (2)	Lead finish/ Ball material (6)	MSL Peak Temp (3)	Op Temp (°C)	Device Marking (4/5)	Samples
BQ76925PW	ACTIVE	TSSOP	PW	20	70	RoHS & Green	NIPDAU	Level-2-260C-1 YEAR	-25 to 85	BQ76925	<a href="#">Samples</a>
BQ76925PWR	ACTIVE	TSSOP	PW	20	2000	RoHS & Green	NIPDAU	Level-2-260C-1 YEAR	-25 to 85	BQ76925	<a href="#">Samples</a>
BQ76925RGER	ACTIVE	VQFN	RGE	24	3000	RoHS & Green	NIPDAU	Level-1-260C-UNLIM	-25 to 85	BQ76925	<a href="#">Samples</a>
BQ76925RGET	ACTIVE	VQFN	RGE	24	250	RoHS & Green	NIPDAU	Level-1-260C-UNLIM	-25 to 85	BQ76925	<a href="#">Samples</a>

(1) The marketing status values are defined as follows:

**ACTIVE:** Product device recommended for new designs.

**LIFEBUY:** TI has announced that the device will be discontinued, and a lifetime-buy period is in effect.

**NRND:** Not recommended for new designs. Device is in production to support existing customers, but TI does not recommend using this part in a new design.

**PREVIEW:** Device has been announced but is not in production. Samples may or may not be available.

**OBSOLETE:** TI has discontinued the production of the device.

(2) **RoHS:** TI defines "RoHS" to mean semiconductor products that are compliant with the current EU RoHS requirements for all 10 RoHS substances, including the requirement that RoHS substance do not exceed 0.1% by weight in homogeneous materials. Where designed to be soldered at high temperatures, "RoHS" products are suitable for use in specified lead-free processes. TI may reference these types of products as "Pb-Free".

**RoHS Exempt:** TI defines "RoHS Exempt" to mean products that contain lead but are compliant with EU RoHS pursuant to a specific EU RoHS exemption.

**Green:** TI defines "Green" to mean the content of Chlorine (Cl) and Bromine (Br) based flame retardants meet JS709B low halogen requirements of <=1000ppm threshold. Antimony trioxide based flame retardants must also meet the <=1000ppm threshold requirement.

(3) MSL, Peak Temp. - The Moisture Sensitivity Level rating according to the JEDEC industry standard classifications, and peak solder temperature.

(4) There may be additional marking, which relates to the logo, the lot trace code information, or the environmental category on the device.

(5) Multiple Device Markings will be inside parentheses. Only one Device Marking contained in parentheses and separated by a "-" will appear on a device. If a line is indented then it is a continuation of the previous line and the two combined represent the entire Device Marking for that device.

(6) Lead finish/Ball material - Orderable Devices may have multiple material finish options. Finish options are separated by a vertical ruled line. Lead finish/Ball material values may wrap to two lines if the finish value exceeds the maximum column width.

**Important Information and Disclaimer:** The information provided on this page represents TI's knowledge and belief as of the date that it is provided. TI bases its knowledge and belief on information provided by third parties, and makes no representation or warranty as to the accuracy of such information. Efforts are underway to better integrate information from third parties. TI has taken and

continues to take reasonable steps to provide representative and accurate information but may not have conducted destructive testing or chemical analysis on incoming materials and chemicals. TI and TI suppliers consider certain information to be proprietary, and thus CAS numbers and other limited information may not be available for release.

In no event shall TI's liability arising out of such information exceed the total purchase price of the TI part(s) at issue in this document sold by TI to Customer on an annual basis.

**TAPE AND REEL INFORMATION**

**QUADRANT ASSIGNMENTS FOR PIN 1 ORIENTATION IN TAPE**

\*All dimensions are nominal

Device	Package Type	Package Drawing	Pins	SPQ	Reel Diameter (mm)	Reel Width W1 (mm)	A0 (mm)	B0 (mm)	K0 (mm)	P1 (mm)	W (mm)	Pin1 Quadrant
BQ76925PWR	TSSOP	PW	20	2000	330.0	16.4	6.95	7.0	1.4	8.0	16.0	Q1
BQ76925RGER	VQFN	RGE	24	3000	330.0	12.4	4.25	4.25	1.15	8.0	12.0	Q2
BQ76925RGET	VQFN	RGE	24	250	180.0	12.4	4.25	4.25	1.15	8.0	12.0	Q2

## TAPE AND REEL BOX DIMENSIONS



\*All dimensions are nominal

Device	Package Type	Package Drawing	Pins	SPQ	Length (mm)	Width (mm)	Height (mm)
BQ76925PWR	TSSOP	PW	20	2000	356.0	356.0	35.0
BQ76925RGER	VQFN	RGE	24	3000	367.0	367.0	35.0
BQ76925RGET	VQFN	RGE	24	250	210.0	185.0	35.0

**TUBE**

\*All dimensions are nominal

Device	Package Name	Package Type	Pins	SPQ	L (mm)	W (mm)	T (μm)	B (mm)
BQ76925PW	PW	TSSOP	20	70	530	10.2	3600	3.5
BQ76925PW	PW	TSSOP	20	70	530	10.2	3600	3.5

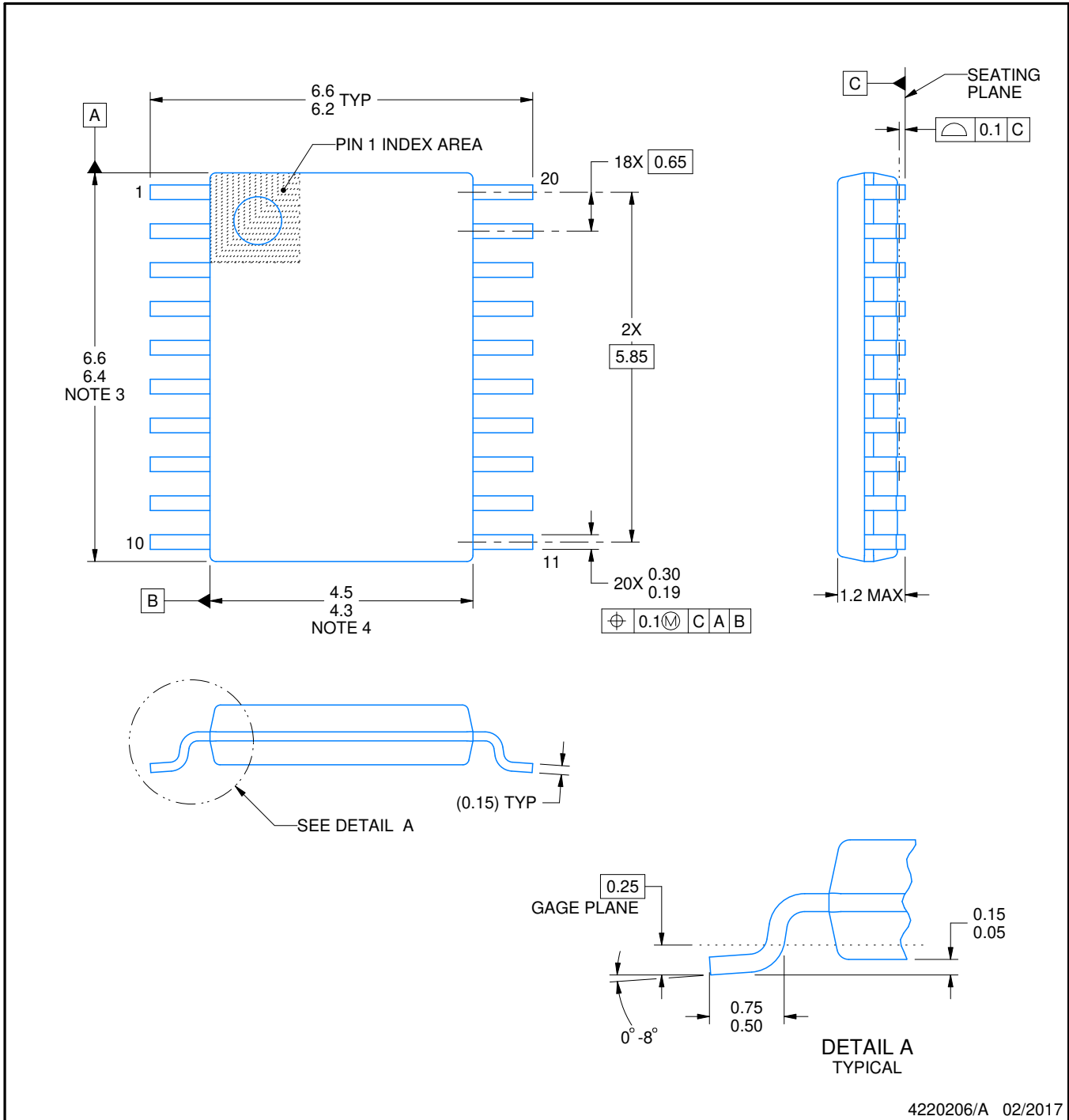

4220206/A 02/2017

NOTES:

1. All linear dimensions are in millimeters. Any dimensions in parenthesis are for reference only. Dimensioning and tolerancing per ASME Y14.5M.
2. This drawing is subject to change without notice.
3. This dimension does not include mold flash, protrusions, or gate burrs. Mold flash, protrusions, or gate burrs shall not exceed 0.15 mm per side.
4. This dimension does not include interlead flash. Interlead flash shall not exceed 0.25 mm per side.
5. Reference JEDEC registration MO-153.



# EXAMPLE BOARD LAYOUT

PW0020A

TSSOP - 1.2 mm max height

SMALL OUTLINE PACKAGE

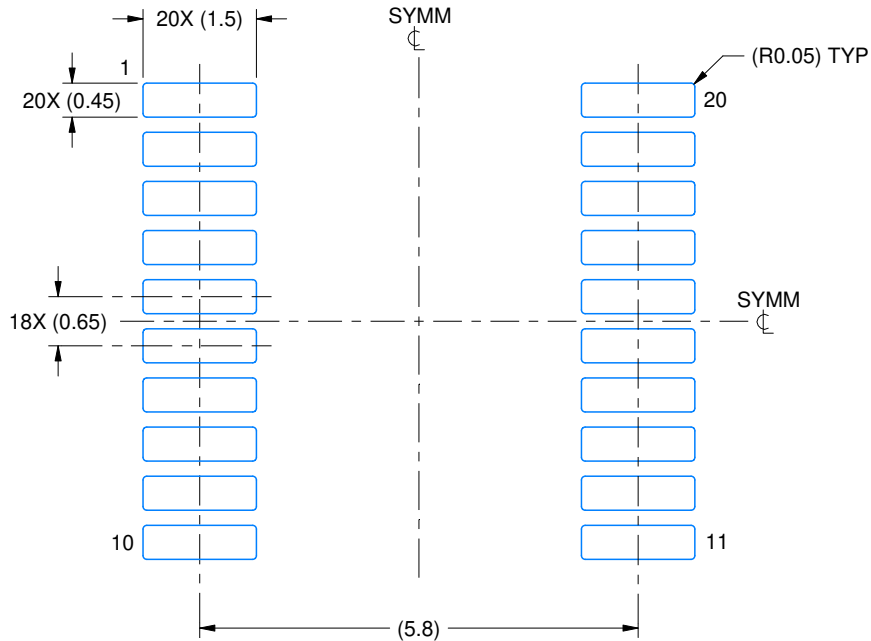

LAND PATTERN EXAMPLE  
EXPOSED METAL SHOWN  
SCALE: 10X

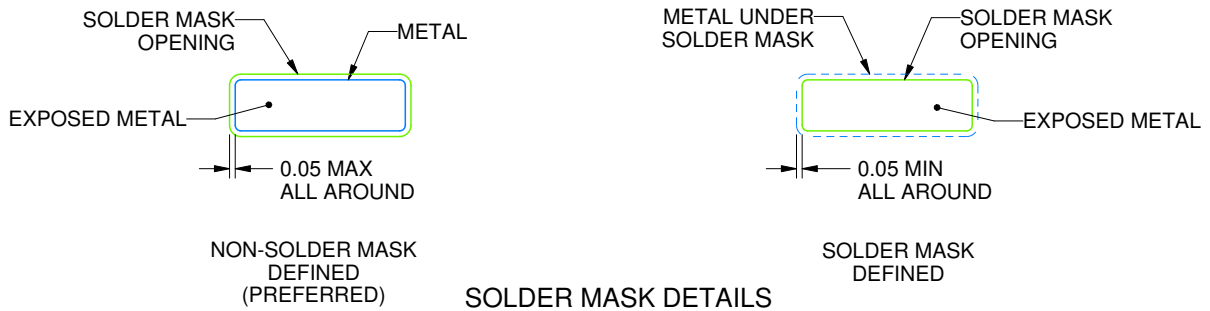

SOLDER MASK DETAILS

4220206/A 02/2017

NOTES: (continued)

- 6. Publication IPC-7351 may have alternate designs.
- 7. Solder mask tolerances between and around signal pads can vary based on board fabrication site.

# EXAMPLE STENCIL DESIGN

PW0020A

TSSOP - 1.2 mm max height

SMALL OUTLINE PACKAGE

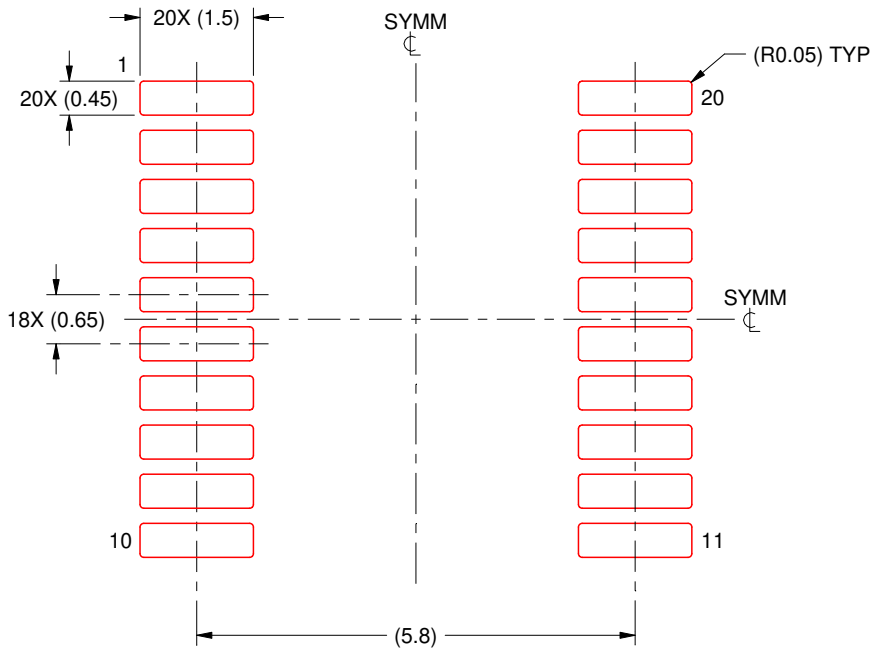

SOLDER PASTE EXAMPLE  
BASED ON 0.125 mm THICK STENCIL  
SCALE: 10X

4220206/A 02/2017

NOTES: (continued)

8. Laser cutting apertures with trapezoidal walls and rounded corners may offer better paste release. IPC-7525 may have alternate design recommendations.
9. Board assembly site may have different recommendations for stencil design.

PW (R-PDSO-G20)

PLASTIC SMALL OUTLINE

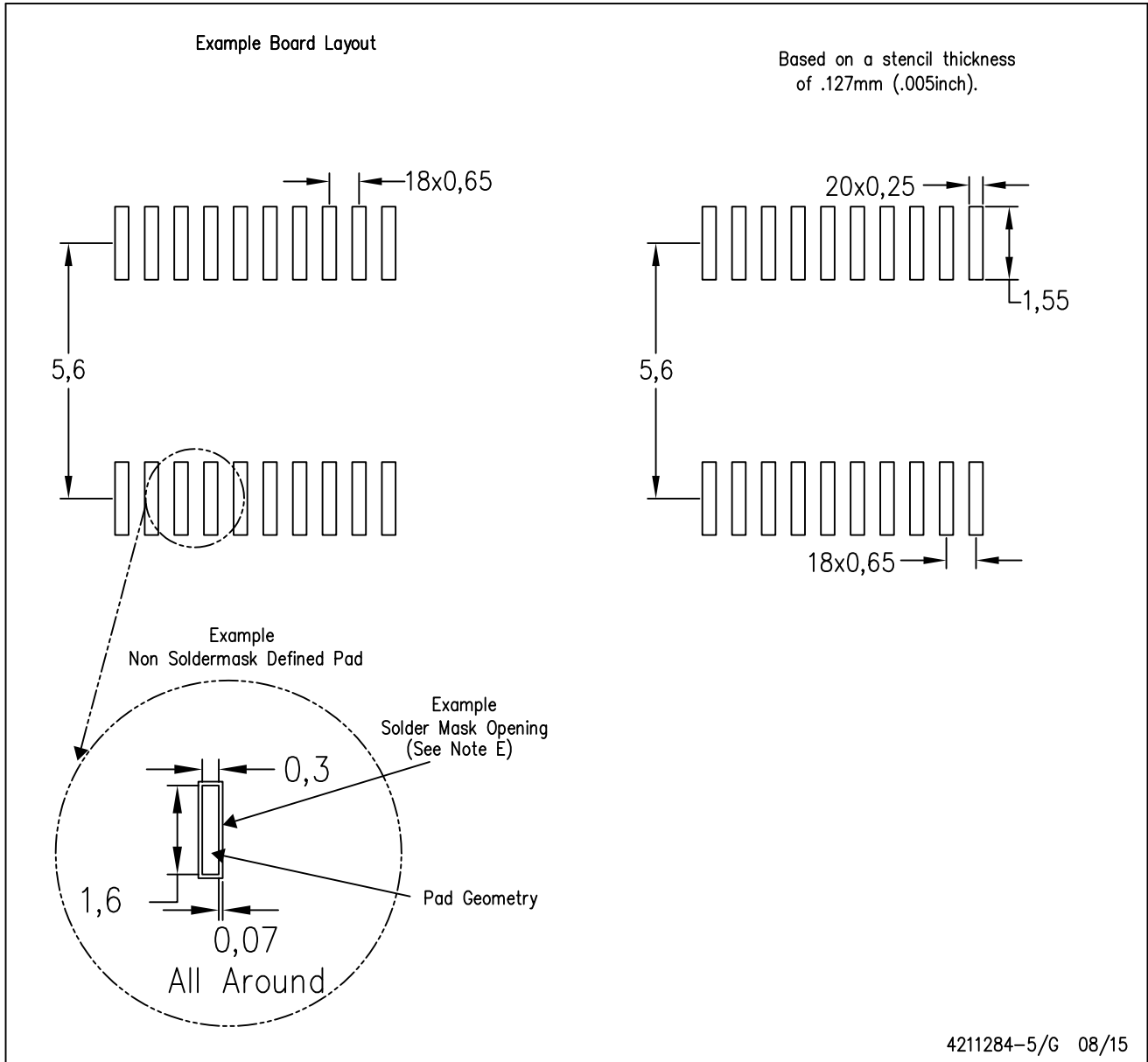

- NOTES:
- A. All linear dimensions are in millimeters.
  - B. This drawing is subject to change without notice.
  - C. Publication IPC-7351 is recommended for alternate design.
  - D. Laser cutting apertures with trapezoidal walls and also rounding corners will offer better paste release. Customers should contact their board assembly site for stencil design recommendations. Refer to IPC-7525 for other stencil recommendations.
  - E. Customers should contact their board fabrication site for solder mask tolerances between and around signal pads.

**RGE 24**

**GENERIC PACKAGE VIEW**

**VQFN - 1 mm max height**

PLASTIC QUAD FLATPACK - NO LEAD

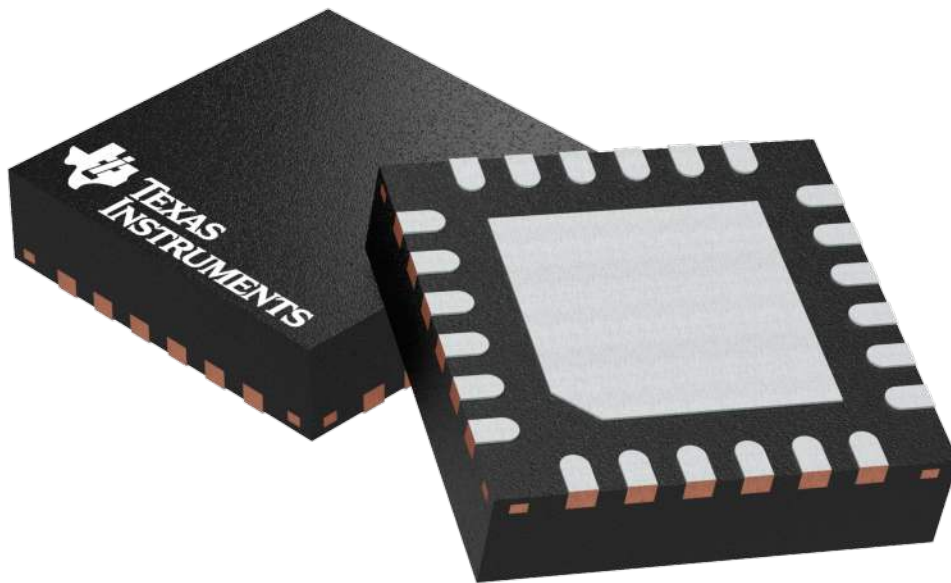

Images above are just a representation of the package family, actual package may vary.  
Refer to the product data sheet for package details.

4204104/H

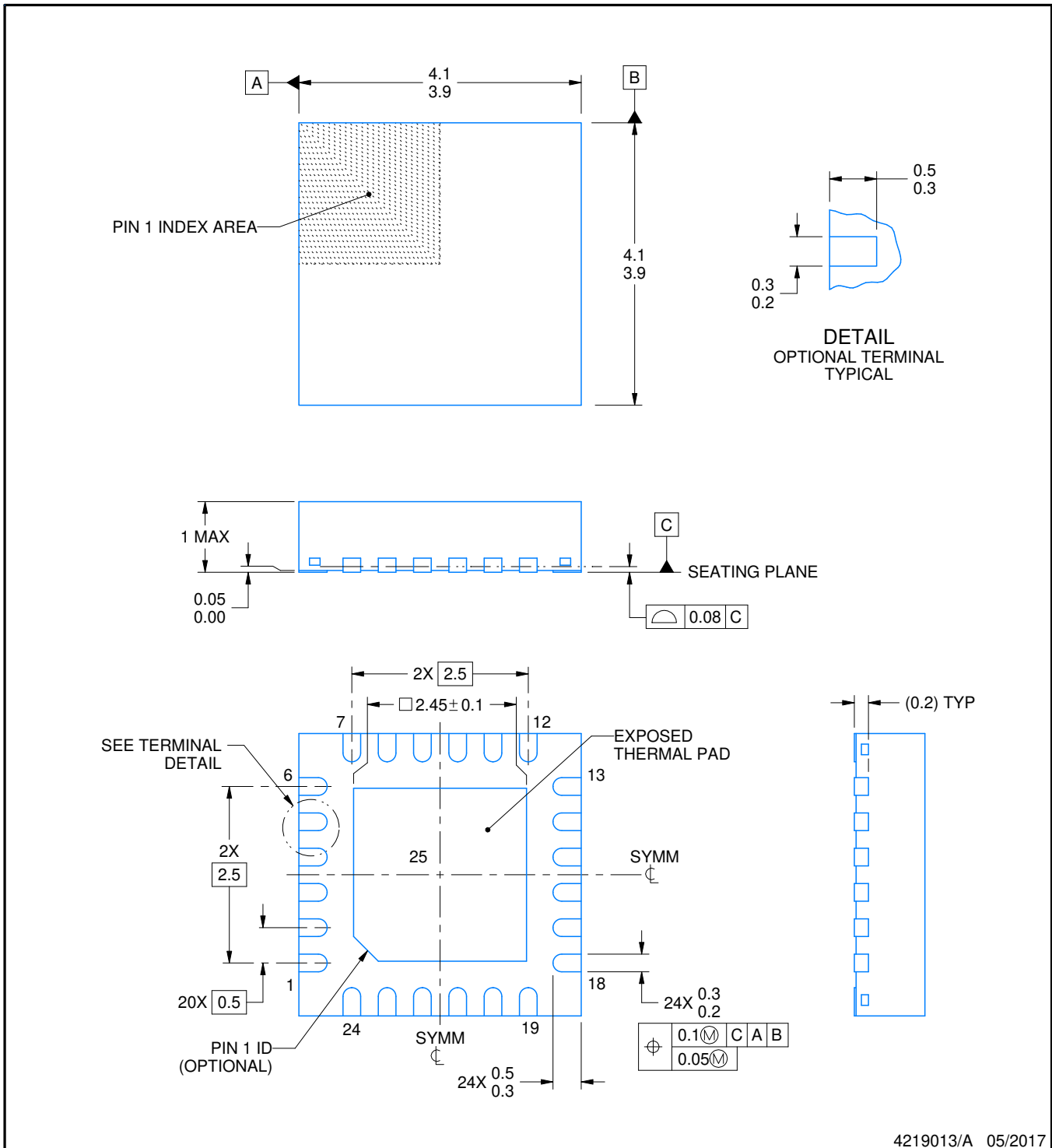

NOTES:

1. All linear dimensions are in millimeters. Any dimensions in parenthesis are for reference only. Dimensioning and tolerancing per ASME Y14.5M.
2. This drawing is subject to change without notice.
3. The package thermal pad must be soldered to the printed circuit board for thermal and mechanical performance.



# EXAMPLE STENCIL DESIGN

RGE0024B

VQFN - 1 mm max height

PLASTIC QUAD FLATPACK - NO LEAD

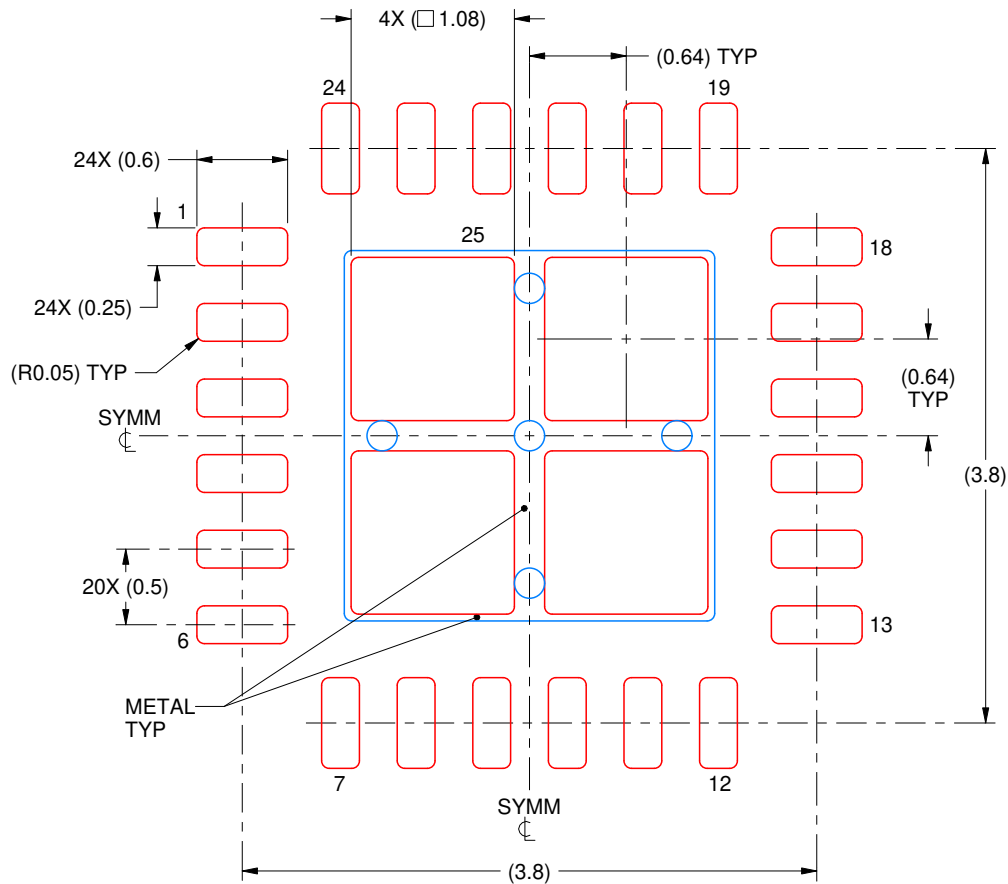

**SOLDER PASTE EXAMPLE**  
 BASED ON 0.125 mm THICK STENCIL

EXPOSED PAD 25  
 78% PRINTED SOLDER COVERAGE BY AREA UNDER PACKAGE  
 SCALE:20X

4219013/A 05/2017

NOTES: (continued)

6. Laser cutting apertures with trapezoidal walls and rounded corners may offer better paste release. IPC-7525 may have alternate design recommendations.

## IMPORTANT NOTICE AND DISCLAIMER

TI PROVIDES TECHNICAL AND RELIABILITY DATA (INCLUDING DATA SHEETS), DESIGN RESOURCES (INCLUDING REFERENCE DESIGNS), APPLICATION OR OTHER DESIGN ADVICE, WEB TOOLS, SAFETY INFORMATION, AND OTHER RESOURCES "AS IS" AND WITH ALL FAULTS, AND DISCLAIMS ALL WARRANTIES, EXPRESS AND IMPLIED, INCLUDING WITHOUT LIMITATION ANY IMPLIED WARRANTIES OF MERCHANTABILITY, FITNESS FOR A PARTICULAR PURPOSE OR NON-INFRINGEMENT OF THIRD PARTY INTELLECTUAL PROPERTY RIGHTS.

These resources are intended for skilled developers designing with TI products. You are solely responsible for (1) selecting the appropriate TI products for your application, (2) designing, validating and testing your application, and (3) ensuring your application meets applicable standards, and any other safety, security, regulatory or other requirements.

These resources are subject to change without notice. TI grants you permission to use these resources only for development of an application that uses the TI products described in the resource. Other reproduction and display of these resources is prohibited. No license is granted to any other TI intellectual property right or to any third party intellectual property right. TI disclaims responsibility for, and you will fully indemnify TI and its representatives against, any claims, damages, costs, losses, and liabilities arising out of your use of these resources.

TI's products are provided subject to [TI's Terms of Sale](#) or other applicable terms available either on [ti.com](http://ti.com) or provided in conjunction with such TI products. TI's provision of these resources does not expand or otherwise alter TI's applicable warranties or warranty disclaimers for TI products.

TI objects to and rejects any additional or different terms you may have proposed.

Mailing Address: Texas Instruments, Post Office Box 655303, Dallas, Texas 75265  
Copyright © 2022, Texas Instruments Incorporated