

PART NO.	A99279-009	REV	ECO	DATE	APP
		A	102791	08-09-16	HV

MATERIALS

- HOUSING:**
ALUMINUM 6061-T6, NICKEL PLATE PER SAE-AMS-2404
- INSULATOR:**
LIQUID CRYSTAL POLYMER (LCP) PER ASTM D5138
- CONTACT:**
COPPER ALLOY PER MIL-DTL-83513, GOLD PLATED PER ASTM B488, (HARD GOLD) TYPE II CODE C CLASS 1.27
- WIRE:**
NEMA HP3 TYPE E, COLOR CODED IAW MIL-STD-681, SYSTEM 1, USING TEN SOLID REPEATING COLORS
- INTERFACIAL SEAL:**
SILICONE RUBBER PER A-A-59588
- HARDWARE:**
STAINLESS STEEL, PASSIVATED PER SAE-AMS-2700

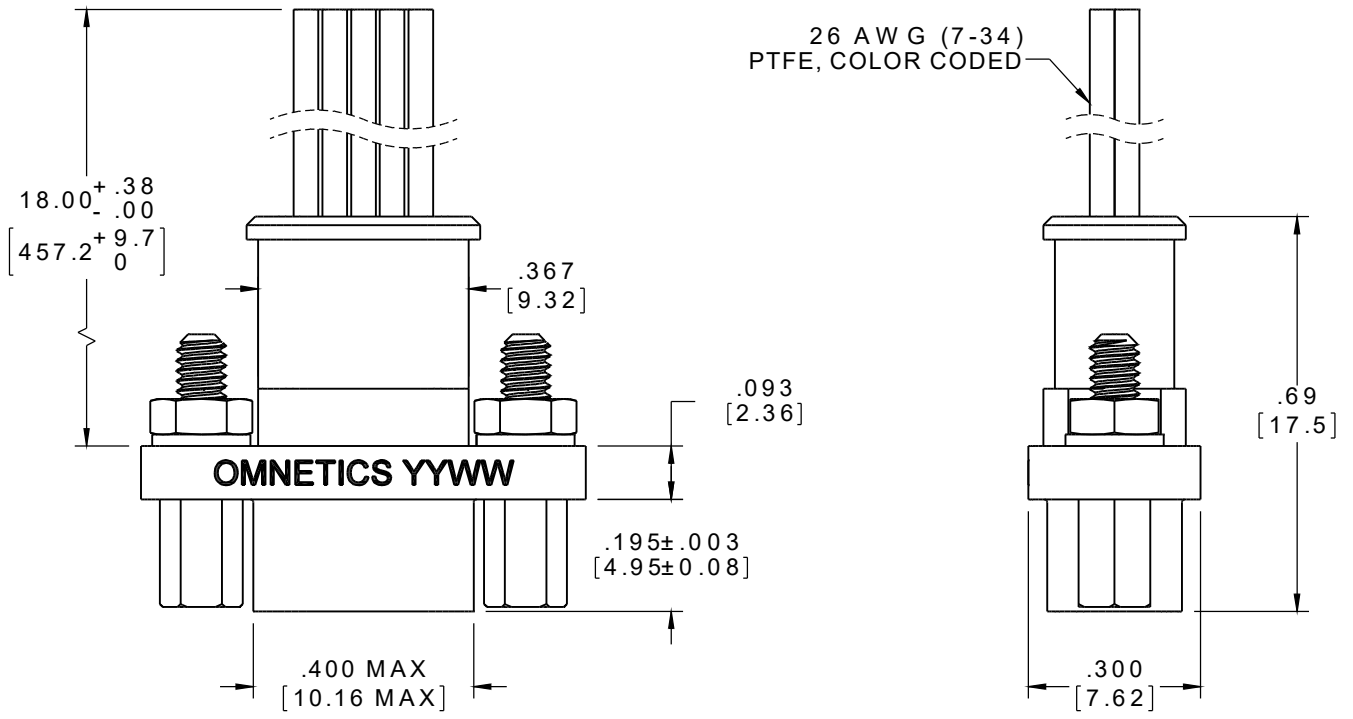

SOCKET #	COLOR
1	BLACK
2	BROWN
3	RED
4	ORANGE
5	YELLOW
6	GREEN
7	BLUE
8	VIOLET
9	GRAY

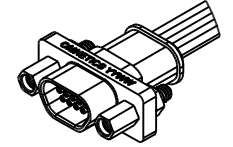
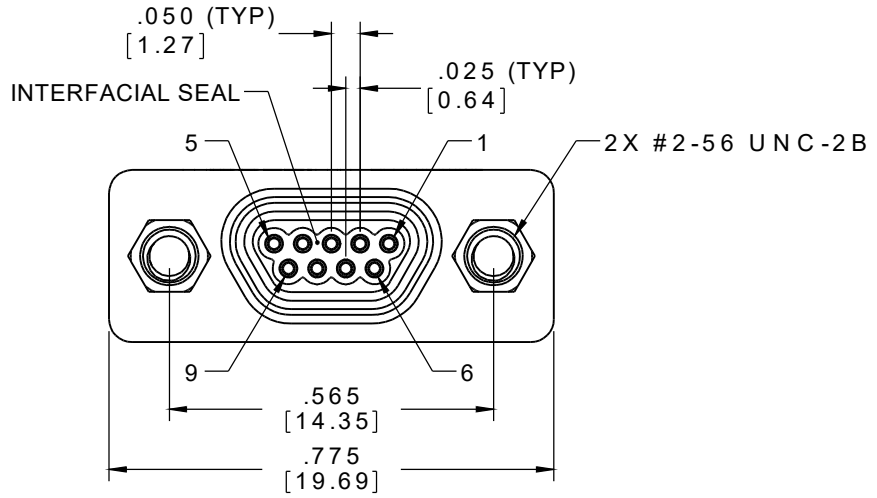

ACTUAL SIZE EXCLUDING WIRE LENGTH

RoHS

NOTE:
DIMENSIONS IN [] ARE IN MILLIMETERS UNLESS OTHERWISE NOTED AND ARE FOR REFERENCE ONLY

MMSD/SMD	THIRD ANGLE	THIS DRAWING CONTAINS CONFIDENTIAL AND PROPRIETARY INFORMATION WHICH IS THE PROPERTY OF OMNETICS CONNECTOR CORP. THIS DOCUMENT MAY NOT, IN WHOLE OR IN PART, BE DUPLICATED, OR DISCLOSED FOR ANY PURPOSE, WITHOUT WRITTEN PERMISSION FROM OMNETICS CONNECTOR CORP.		OMNETICS	CAGE CODE 61873	
	-TOLERANCES-	DFTM. HV	DATE 05-31-16		CONNECTOR CORPORATION	DWG NO. A99279-009
	UNLESS OTHERWISE NOTED	CHK'D.	DATE	7260 COMMERCE CIRCLE EAST	SHEET 1 OF 1	REV
	DIMENSIONS IN INCHES	APP'D.	DATE	MINNEAPOLIS, MN 55432	SCALE: 3:1	A

TITLE: (9) SOCKET FEMALE MICRO-D CONNECTOR W/ JACKPOSTS

WWW.OMNETICS.COM