

MATERIALS & SPECIFICATIONS

PART NO.	A29100-031	REV	ECO	DATE	APP
		K	102551	05-03-16	TLM

- HOUSING:**
ALUMINUM 6061-T6, NICKEL PLATE PER SAE-AMS-2404
- INSULATOR:**
LIQUID CRYSTAL POLYMER (LCP) PER ASTM D5138
- CONTACTS:**
COPPER ALLOY PER MIL-DTL-32139, GOLD PLATED PER ASTM B488, (HARD GOLD) TYPE II CODE C CLASS 1.27
- TERMINATIONS:**
SOLDER COATED WITH SN63A PER J-STD-006
- CURRENT RATING:**
1 AMP MAX PER MIL-DTL-32139
- CONTACT RESISTANCE:**
71 MILLIOHM MAX (71mV DROP MAX) @ 1.0 AMPS PER MIL-DTL-32139
- PERFORMANCE:**
PRODUCT FAMILY TESTED TO AND PASSED THE PERFORMANCE SPECIFICATIONS OF TABLE VIII OF MIL-DTL-32139

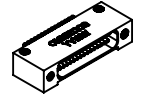
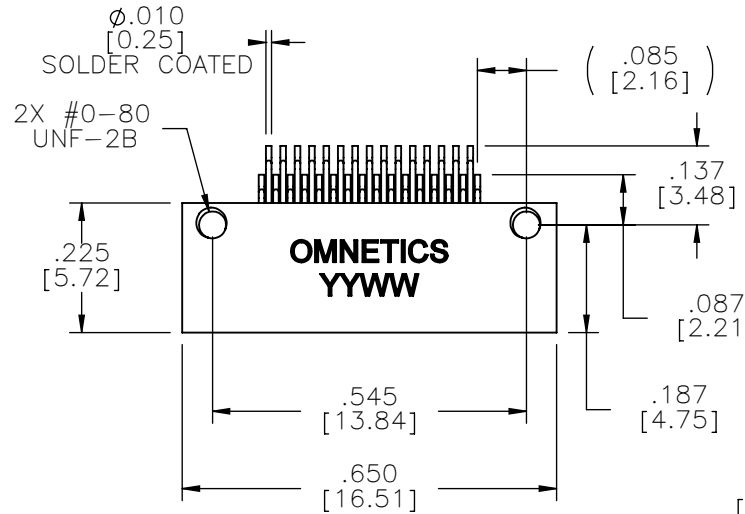

ACTUAL SIZE

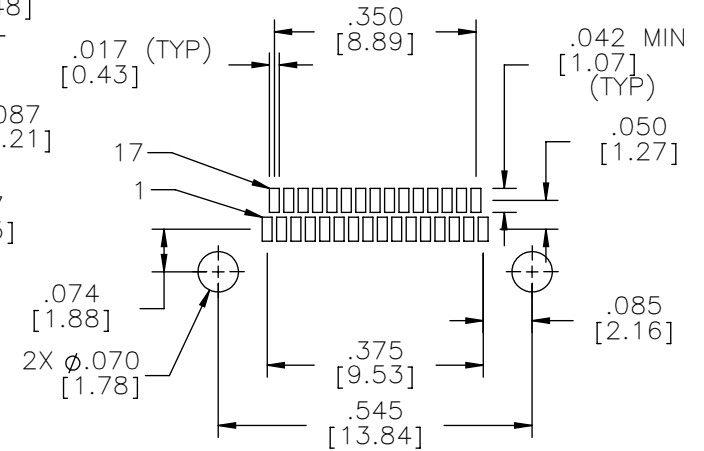

SUGGESTED PAD LAYOUT

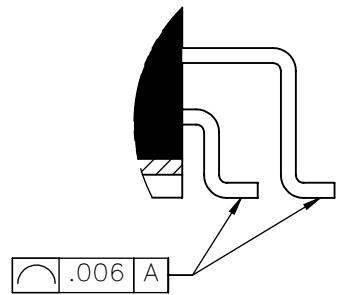

DETAIL B
SCALE 8 : 1

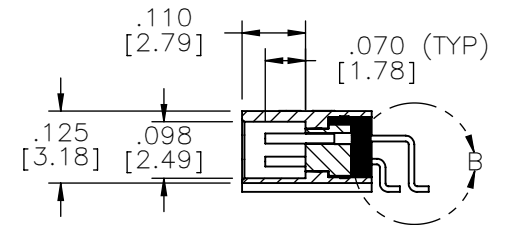
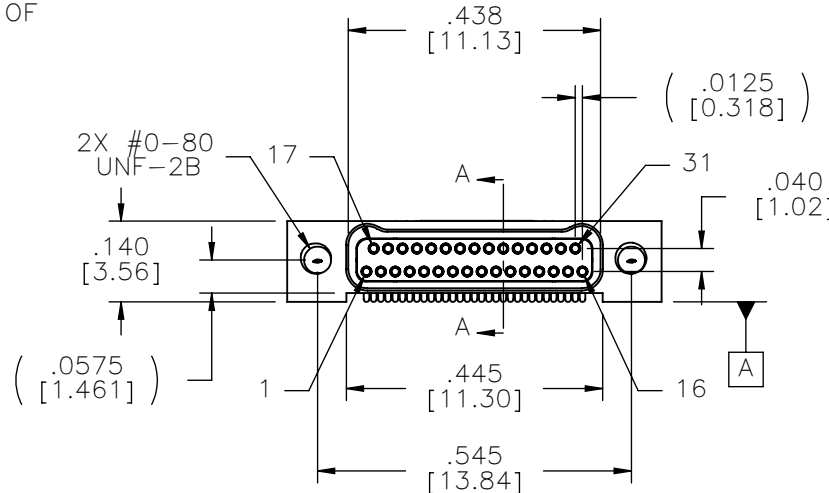

SECTION A-A

NOTE:

DIMENSIONS IN [] ARE IN MILLIMETERS UNLESS OTHERWISE NOTED AND ARE FOR REFERENCE ONLY

MCTCS	THIRD ANGLE
	-TOLERANCES-
	UNLESS OTHERWISE NOTED
	DIMENSIONS IN INCHES
2	PL DEC ± .01
3	PL DEC ± .005
4	PL DEC ± .0005
	ANGLES ± 1°

THIS DRAWING CONTAINS CONFIDENTIAL AND PROPRIETARY INFORMATION WHICH IS THE PROPERTY OF OMNETICS CONNECTOR CORP. THIS DOCUMENT MAY NOT, IN WHOLE OR IN PART, BE DUPLICATED, OR DISCLOSED FOR ANY PURPOSE, WITHOUT WRITTEN PERMISSION FROM OMNETICS CONNECTOR CORP.

DFTM.	AAS	DATE	05-10-04
CHK'D.		DATE	
APP'D.		DATE	

TITLE:
(31) SOCKET FEMALE
Bi-Lobe® CONNECTOR

OMNETICS
CONNECTOR CORPORATION
7260 COMMERCE CIRCLE EAST
MINNEAPOLIS, MN 55432
WWW.OMNETICS.COM

CAGE CODE	61873
DWG NO.	A29100-031
SHEET 1 OF 1	REV K
SCALE:	3:1