

## GC5325 Wideband Digital Predistortion Transmit Processor

### FEATURES

- Integrated CFR and DPD Functions
- Up to 20-MHz Combined Signal Bandwidth
- CFR: Typically Meets 3GPP TS 25.141 <6.5 dB PAR, <8 dB PAR for 802.16e Signals
- DPD: Memory Compensation, Typical ACLR Improvement of 20 dB to 30 dB or More
- Transmit- and Feedback-Channel Equalizers
- 352-Ball S-PBGA Package, 27 mm × 27 mm
- 1.2-V Core, 3.3-V I/O
- Typical Power Consumption = 1.9 W

- Flexible DSP Algorithm Supports Existing and Emerging Wireless Standards
- Supports Direct Interface to TI High-Speed Data Converters

### APPLICATIONS

- 3GPP (W-CDMA, TD-SCDMA) Base Stations
- 3GPP2 (CDMA2000) Base Stations
- WiMAX and WiBRO (OFDMA) Base Stations
- Multicarrier Power Amplifiers (MCPAs)

### SYSTEM BLOCK DIAGRAM

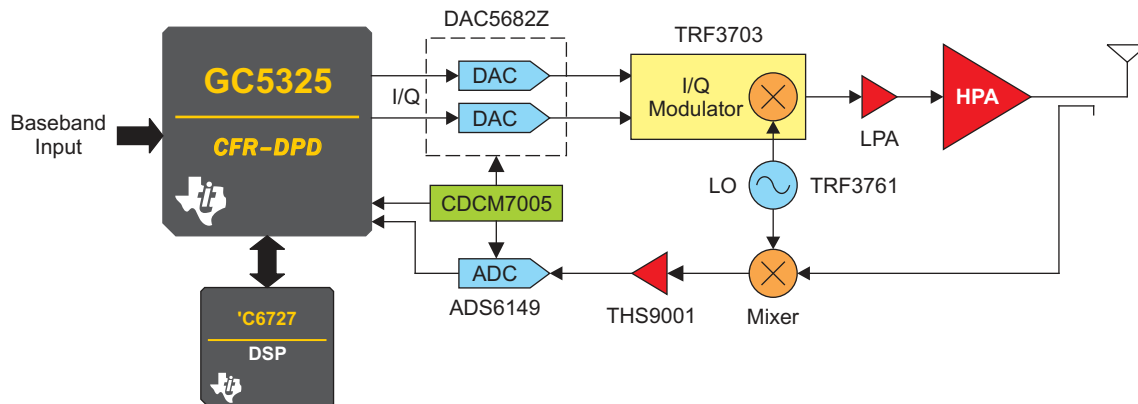

B0278-02

### DESCRIPTION

The GC5325 is a wideband digital predistortion transmit processor that includes a crest factor reduction (CFR) block and a digital predistortion (DPD) block with its associated feedback chain and capture buffers. The GC5325 processes composite input bandwidths of up to 20 MHz and processes DPD sample rates of up to 140 MHz. The GC5325 accepts a composite signal over an interleaved parallel interface at a data rate of up to 140 MSPS. The GC5325 CFR block reduces the peak-to-average ratio (PAR) of wideband digital signals provided in quadrature (I/Q) format, such as those used in third-generation (3G) code division multiple access (CDMA) wireless and orthogonal frequency division multiple access (OFDMA) applications. The GC5325 DPD block reduces adjacent-channel leakage ratio (ACLR), or out-of-band energy, by 20 dB to 30 dB or more. The efficiency of follow-on power amplifiers (PAs) is substantially improved by reducing the PAR and ACLR of digital signals. The digital-to-RF conversion can be further simplified by the fractional interpolator between the CFR and the DPD blocks, and a bulk upconverter (BUC) in the final stage of the GC5325. This feature typically eliminates the need for superheterodyne (dual-stage) upconversion architectures. Transmit and feedback NCO/mixers provide additional flexibility in the system frequency planning.



Please be aware that an important notice concerning availability, standard warranty, and use in critical applications of Texas Instruments semiconductor products and disclaimers thereto appears at the end of this data sheet.

TMS320C64x, C55x, C64x are trademarks of Texas Instruments.  
All other trademarks are the property of their respective owners.



These devices have limited built-in ESD protection. The leads should be shorted together or the device placed in conductive foam during storage or handling to prevent electrostatic damage to the MOS gates.

**AVAILABLE OPTIONS**

<b>T<sub>c</sub></b>	<b>PACKAGED DEVICE<sup>(1)</sup></b>
	<b>352-ball S-PBGA package, 27 mm x 27 mm</b>
	GC5325IZND
–40°C to 85°C	

(1) For the most current package and ordering information, see the Package Option Addendum at the end of this document, or see the TI website at [www.ti.com](http://www.ti.com).

**GC5325 FUNCTIONAL BLOCK DIAGRAM**

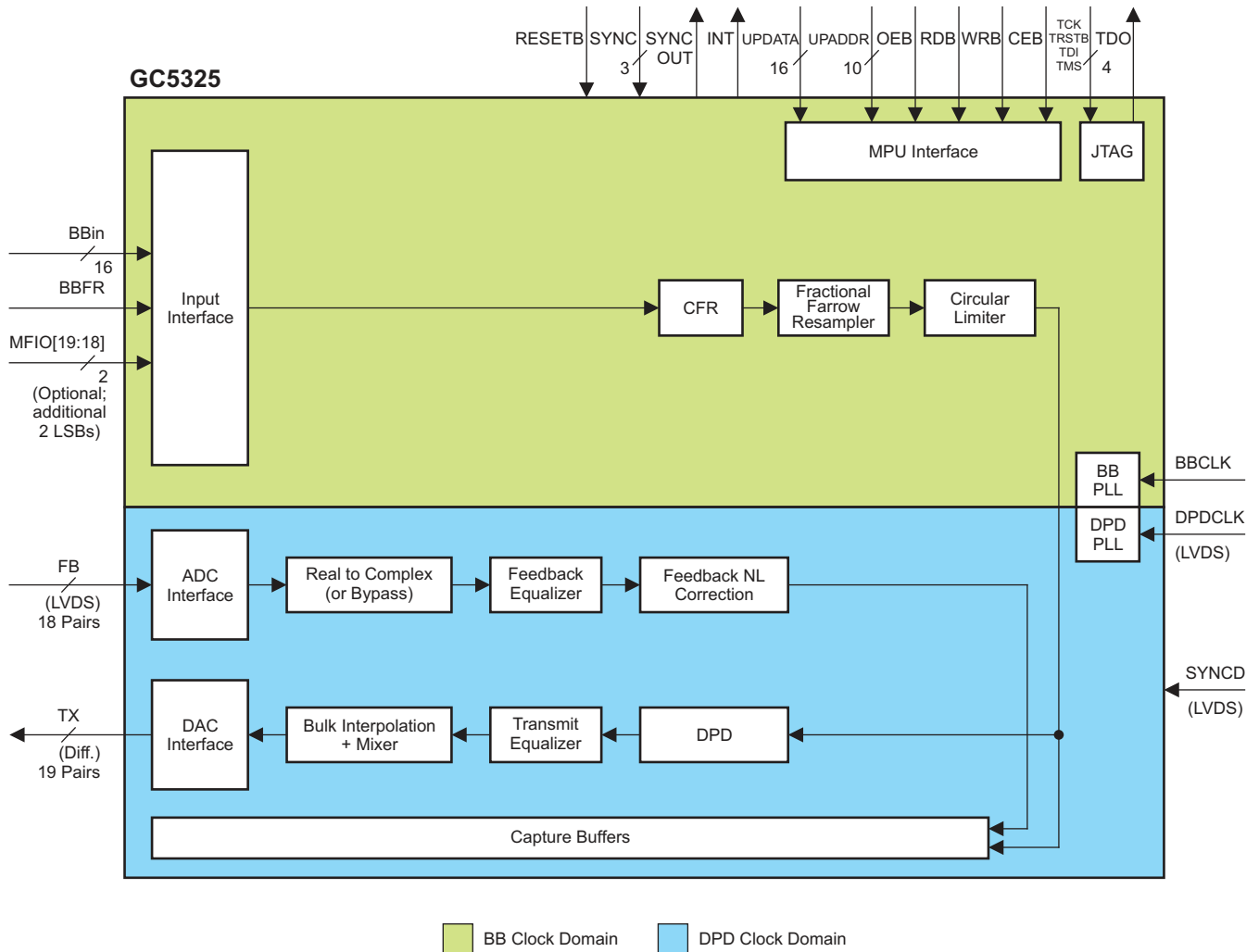

B0279-02

## DETAILED DESCRIPTION

### GC5325 Introduction

The GC5325 is a flexible transmit sector processor that includes a crest factor reduction (CFR) block and a digital predistortion (DPD) block and its associated feedback chain. The GC5325 processes composite input bandwidths of up to 40 MHz and processes DPD expansion bandwidths of up to 140 MHz (actual performance may vary for signal bandwidths exceeding 23 MHz). By reducing both the peak-to-average ratio (PAR) of the input signals using the CFR block and linearizing the power amplifier (PA) using the DPD block, the GC5325 reduces the costs of multicarrier PAs (MCPA) for wireless infrastructure applications. The GC5325 applies CFR and DPD while a separate microprocessor (a Texas Instruments TMS320C6727 DSP) is used to optimize performance levels and maintain target PA performance levels.

By including the GC5325 in their system architecture, manufacturers of BTS equipment can realize significant savings on power amplifier bill of materials (BOM) and overall operational costs due to the PA efficiency improvement. The GC5325 meets multicarrier 3G performance standards (PCDE, composite EVM, and ACLR) at PAR levels down to 6.5 dB and improves the ACLR, at the PA output, by 20 dB to 30 dB or more. The GC5325 integrates easily into the transmit signal chain between baseband processors such as the Texas Instruments TMS320C64x™ DSP family and their high-performance data converters.

A typical GC5325 system application would include the following transmit-chain components:

- TMS320C6727 digital signal processor (DSP)
- DAC5682 16-bit, 1-GSPS DAC (transmit path)
- CDCM7005 clock generator
- TRF3761 integrated VCO/PLL synthesizer
- TRF3703 quadrature modulator
- ADS5517 11-bit 200-MSPS or ADS6149 14-bit, 250-MSPS ADC (feedback path)
- AMC7823 analog monitoring and control circuit with GPIO and SPI

### Baseband Interface

The GC5325 BB interface block accepts baseband signals over an interleaved parallel interface at a data rate of up to 140 MHz. The input interface supports up to 12 separate baseband carriers. The GC5325 input interface can be programmed in a wideband mode in which users are required to channelize the data using an external processor.

### Gain/Pilot Insertion/AntCal Insertion/Power Meter

Baseband gain can be applied on a per-carrier basis to accurately control the individual channel power through the system. Also present is the functionality for adding pilot codes to the data stream for antenna calibration applications. Independent programmable RMS power meters for up to 12 channels are also included in this block of the device.

### Crest Factor Reduction (CFR)

The GC5325 CFR block selectively reduces the peak-to-average ratio (PAR) of wideband digital signals provided in quadrature (I and Q) format, such as those used in third-generation (3G) code division multiple access (CDMA) wireless applications. The CFR block can reduce the PAR of W-CDMA Test Model 1 and Test Model 3 signals down to 6.5 dB output PAR while still meeting all 3GPP requirements for ACLR, composite EVM, and peak code domain error (PCDE). The CFR block accepts input sampling rates up to 140 MSPS complex from the input interface.

## Fractional Farrow Resampler (FR)

The CFR block output signal bandwidth is up to 40 MHz wide, sampled at up to 70 MSPS. However; the DPD block provides PA compensation over an expansion bandwidth of up to 140 MHz, using a complex sampling rate of up to 140 MSPS. To provide the requisite sampling rate of up to 140 MSPS at the input to DPD, the output of the CFR block must be resampled. The GC5325 performs this (nominally 2 $\times$ ) upsampling function using a Farrow filter resampler. The user-programmable Farrow resampler supports upsampling rates from 1 $\times$  to 64 $\times$ , with 16-bit precision on the interpolation ratio. It marks the transition of the input clock domain (driven by the input interface clock) to the transmit domain (driven by the DAC sampling clock).

## Digital Predistortion (DPD)

The DPD block provides predistortion for up to Nth-order nonlinearities, and can correct multiple orders and lengths of PA memory effects. The predistortion correction terms are computed by an external processor (for example, TI TMS320C6727 DSP) based on PA feedback data captured in the GC5325. The external processor reads the captured data buffers from the GC5325 and writes back the newly computed DPD correction terms on a continuous basis. TI provides a base delivery of 'C6727 software to GC5325 customers that achieves a typical ACLR improvement of 20 dB to 30 dB or more when compared to a PA without DPD. The standard EMIF bus allows the user to provide an alternate DPD adaptation algorithm and DSP embodiment, if desired.

## Bulk Upconverter (BUC)

The bulk upconverter block can interpolate the DPD block output by 1.5 $\times$ , 2 $\times$ , 3 $\times$  with a complex output, or 6 $\times$  with a real output. The complex-to-real converter block optionally modifies the DPD complex output stream into a real output stream. The bulk upconverter has flexible mixing options between its various interpolation stages. When used in combination, the bulk upconverter and the complex-to-real functions allow the GC5325 to output a 16-bit real signal at up to 840 MSPS, or a complex signal at up to 420 MSPS. Next-generation data converters can accept sampling rates as high as 1 GSPS and sample widths of 16 bits. In a typical application, the bulk upconverter outputs a 737.28-MSPS real sampling rate (16 bits/sample) directly to the DAC on a modified center frequency of 184.32 MHz (1/4 of the 737.28-MSPS sampling rate). The bulk upconverter has multiple high-speed, low-voltage, single-ended/differential output interfaces to existing and future TI DACs.

## Feedback Path (FB)

The feedback block accepts an external A/D converter input that represents the PA output signal. This feedback signal is processed by a feedback path that adjusts for gain, frequency, and phase anomalies in the RF-to-IF downconversion chain. The feedback path includes an 8-tap complex receive equalizer and lookup tables that can compensate for the nonlinearities in the RF-to-IF part of the feedback chain. The block also includes a real-to-complex conversion to facilitate signal processing. The GC5325 connects directly to the ADS5444, ADS5545, ADS5546, and ADS5517 among others, without requiring external components. The GC5325 simplifies timing by providing a FIFO for each ADC port, sampling the input data using the ADC data-ready signal.

## Microprocessor Interface (MPU)

The MPU interface is designed to interface with external memory interface (EMIF) ports on TI DSPs operating in asynchronous mode. It consists of a 16-bit bidirectional data bus, a 10-bit address bus, and RDB, WRB, OEB, and CEB control signals. The interface fully supports TI C55x™, C64x™ DSPs and, with minimal effort, supports the low-cost 'C6727 floating-point DSP.

## Smart Capture Buffers (SCB)

The GC5325 has two capture buffers, each 4096 complex words deep, which are periodically read by the external coefficient update controller (DSP) in order to optimize the DPD coefficients. The first capture buffer can be used to capture:

- The output of the Farrow resampler; this is also called the reference signal.
- The feedback output; this represents the waveform as seen by the PA.
- The error output
- Testbus(31:16)

The second capture buffer can be used to provide:

- The output of the Farrow resampler; this is also called the reference signal.
- The feedback output; this represents the waveform as seen by the PA.
- The error output
- Testbus(15:0)

The reference and feedback buffers are time-aligned by the GC5325, because there may be a delay of tens or even hundreds of samples between the transmitted signal and the feedback signal from the PA output. The capture controller can trigger a capture on several different metrics, including an above-threshold peak count or an average signal power value.

### Input and Output Syncs

The GC5325 features multiple-user programmable input syncs. These are typically used as trigger mechanisms to activate features within the device. These triggers can be provided internally or through externally provided inputs. The input syncs can be used to trigger:

- Power measurements
- Initializing/loading the feedback, equalizer, LUTs, etc.
- Flush out data within the processing blocks of the device
- Feedback path tuner alignment
- Capturing and sourcing of data through SCBs

### Programmable Power Meters

There are three power meter locations/functions within the GC5325. The first is a channel RMS power meter. The second power meter is located at the output of the CFR block, and the final power detector is similar to the CFR output power detector and is located at the Farrow resampler output. This power meter can measure RMS power integrated up to a million samples at the DPD sample rate.

### Pin Assignment and Descriptions

GND Package  
(Bottom View)

	26	25	24	23	22	21	20	19	18	17	16	15	14	13	12	11	10	9	8	7	6	5	4	3	2	1
A	VSS1	VSS1	VSS1	VSS1	FB1	FB5	FB9	FB11	FB15	FB17	FB21	FB25	FB27	VDD SHV	FB31	FB35	VSSA2	SYNCC	BB15	BB11	BB7	BB3	BB0	VSS1	VSS1	VSS1
B	VDD1	VSS1	VSS1	VSS1	FB0	FB4	FB8	FB10	FB14	FB16	FB20	FB24	FB26	VDD SHV	FB30	FB34	VDDA2	SYNCC	BBFR	BB12	BB8	BB4	BB1	VSS1	VSS1	VDD1
C	VSS1	VDD1	VSS1	VSS1	NC	FB3	FB7	VDD1	FB13	ADC IREF	FB19	FB23	VDD1	VDD SHV	FB29	FB33	VDD1	SYNCA	BBCLK	BB13	BB9	BB5	BB2	VSS1	VDD1	VSS1
D	VSS1	VSS1	VDD1	VSS1	NC	FB2	FB6	VDD1	FB12	ADC VREF	FB18	FB22	VDD1	VDD SHV	FB28	FB32	VSS1	SYNC OUT	VDD1	BB14	BB10	BB6	VSS1	VDD1	VSS1	VSS1
E	VSS1	VSS1	VSS1	VDD1																			VDD1	VSS1	VSS1	VSS1
F	VSS1	VSS1	VSS1	VDD1																			VDD1	VDD1	VSS1	VSS1
G	VSS1	VSS1	VSS1	VDD SHV																			VDD SHV	VSS1	VSS1	VSS1
H	NC	NC	VPP1	VDD1																			VDD1	UP ADDR2	UP ADDR1	UP ADDR0
J	VPP1	NC	NC	VDD1																			VDD1	UP ADDR5	UP ADDR4	UP ADDR3
K	NC	NC	VDD SHV	VDD1																			VDD1	UP ADDR8	UP ADDR7	UP ADDR6
L	NC	NC	NC	VDD1																			VDD1	VDD SHV	WRB	UP ADDR9
M	NC	NC	NC	VDD1																			VDD1	OEB	CEB	RDB
N	NC	NC	VDD SHV	VDD1																			VDD1	UP DATA2	UP DATA1	UP DATA0
P	NC	NC	MFIO18	VDD1																			VDD1	VDD SHV	VSS1	VSS1
R	MFIO19	NC	NC	VDD1																			VDD1	UP DATA5	UP DATA4	UP DATA3
T	NC	NC	NC	VDD1																			VDD1	VDD SHV	VPP2	UP DATA6
U	NC	NC	VDD SHV	VDD1																			VDD1	UP DATA8	UP DATA7	VPP2
V	NC	NC	NC	VDD1																			VDD1	UP DATA11	UP DATA10	UP DATA9
W	NC	NC	NC	VDD1																			VDD1	UP DATA14	UP DATA13	UP DATA12
Y	NC	VSS1	VSS1	VDD1																			VDD SHV	VSS1	VSS1	UP DATA15
AA	VSS1	VSS1	VSS1	VDD1																			VDD1	VSS1	VSS1	VSS1
AB	VSS1	VSS1	VSS1	VDD1																			VDD1	VDD1	VSS1	VSS1
AC	VSS1	VSS1	VDD1	RESET B	VDD SHV	DPD CLK	VSS1	VDD1	TX2	TX6	TX10	TX14	VDD1	VSS1	DAC REFP	TX25	TX29	TX33	TX37	VSS1	VDD1	VDD2	VSS1	VDD1	VSS1	VSS1
AD	VSS1	VDD1	VSS1	VSS1	DPD IREF	DPD CLKC	VSS1	VDDA1	TX3	TX7	TX11	TX15	VDD1	VSS1	DAC REFN	TX24	TX28	TX32	TX36	VDD SHV	VDD1	VSS2	VSS1	VSS1	VDD1	VSS1
AE	VDD1	VSS1	VSS1	VSS1	DPD VREF	SYNCD	VDD SHV	TX0	TX4	TX8	TX12	TX16	VDD1	TX19	TX21	TX23	TX27	TX31	TX35	TRSTB	TDI	INTERRUPT	VSS1	VSS1	VSS1	VDD1
AF	VSS1	VSS1	VSS1	VSS1	VSS1	SYNC DC	VSSA1	TX1	TX5	TX9	TX13	TX17	VSS1	TX18	TX20	TX22	TX26	TX30	TX34	TMS	TCK	TDO	TEST MODE	VSS1	VSS1	VSS1

- = Baseband Input
- = Transmit Output
- = Feedback Input
- = Microprocessor Interface
- = Miscellaneous
- = Multi-Function Input/Output
- = Power and Biasing
- = JTAG Interface
- = NC

P0077-01

**Table 1. TERMINAL FUNCTIONS**

TERMINAL		I/O	DESCRIPTION
NAME	NO.		
<b>MICROPROCESSOR INTERFACE</b>			
OEB	M3	I	Output enable
CEB	M2	I	Chip enable
RDB	M1	I	Read
WRB	L2	I	Write
UPADDR[9:0]	L1, K3, K2, K1, J3, J2, J1, H3, H2, H1	I	Microprocessor address
UPDATA[15:0]	Y1, W3, W2, W1, V3, V2, V1, U3, U2, T1, R3, R2, R1, N3, N2, N1	I/O	Microprocessor data
INTERRUPT	AE5	O	Microprocessor interrupt
<b>POWER AND BIASING</b>			
VDD1	B1, B26, C2, C10, C14, C19, C25, D3, D8, D14, D19, D24, E4, E23, F3, F4, F23, H4, H23, J4, J23, K4, K23, L4, L23, M4, M23, N4, N23, P4, P23, R4, R23, T4, T23, U4, U23, V4, V23, W4, W23, Y23, AA4, AA23, AB3, AB4, AB23, AC3, AC6, AC19, AC24, AD2, AD6, AD25, AE1, AE26	PWR	1.2-V supply
VSS1	A1, A2, A3, A23, A24, A25, A26, B2, B3, B23, B24, B25, C1, C3, C23, C24, C26, D1, D2, D4, D10, D23, D25, D26, E1, E2, E3, E24, E25, E26, F1, F2, F24, F25, F26, G1, G2, G3, G24, G25, G26, P1, P2, Y2, Y3, Y24, Y25, AA1, AA2, AA3, AA24, AA25, AA26, AB1, AB2, AB24, AB25, AB26, AC1, AC2, AC4, AC7, AC13, AC20, AC25, AC26, AD1, AD3, AD4, AD13, AD20, AD23, AD24, AD26, AE2, AE3, AE4, AE23, AE24, AE25, AF1, AF2, AF3, AF14, AF22, AF23, AF24, AF25, AF26	PWR	Ground
VDD2	AC5	NC	Do not connect
VSS2	AD5	NC	Do not connect
VDDS	AC14, AD14, AE14	PWR	1.8-V supply
VDDSHV	A13, B13, C13, D13, G4, G23, K24, L3, N24, P3, T3, U24, Y4, AC22, AD7, AE20	PWR	3.3-V supply
VDDA1	AD19	PWR	1.2-V supply (requires filtering)
VSSA1	AF20	PWR	Ground (requires filtering)
VDDA2	B10	PWR	1.2-V supply (requires filtering)
VSSA2	A10	PWR	Ground (requires filtering)
VPP1	H24, J26	PWR	1.2-V supply
VPP2	T2, U1	PWR	1.2-V supply
DPDIREF	AD22	PWR	DPD bias 1 k $\Omega$ to VSS
DPDVREF	AE22	PWR	DPD bias to VDD
DACREFP	AC12	PWR	DAC bias 50- $\Omega$ to VSS
DACREFN	AD12	PWR	DAC bias 50- $\Omega$ to VDDS
ADCIREF	C17	PWR	ADC bias 1 k $\Omega$ to VSS
ADCVREF	D17	PWR	ADC bias to VDD
<b>BASEBAND INPUT</b>			
BB[15:0]	A8, D7, C7, B7, A7, D6, C6, B6, A6, D5, C5, B5, A5, C4, B4, A4	I	Baseband input signal
BBCLK	C8	I	Baseband input clock
BBFR	B8	I	Baseband frame for sample and channel timing
MFIO[19:18]	R26, P24	I	LSBs for 18-bit baseband input signal [-2, -1]
<b>MISCELLANEOUS</b>			
RESETB	AC23	I	Chip reset (active-low .Required.)

**Table 1. TERMINAL FUNCTIONS (continued)**

TERMINAL		I/O	DESCRIPTION
NAME	NO.		
SYNCA	C9	I	Programmable general-purpose sync
SYNCB	B9	I	Programmable general-purpose sync
SYNCC	A9	I	Programmable general-purpose sync
SYNCD	AE21	I	Programmable general-purpose sync
SYNCDC	AF21	I	Complementary of SYNCD
SYNCOUT	D9	O	Programmable general-purpose sync output
DPDCLK	AC21	I	Clock to DPD
DPDCLKC	AD21	I	Complementary clock to DPD
TESTMODE	AF4	I	Tie to ground
<b>JTAG INTERFACE</b>			
TCK	AF6	I	JTAG clock
TDI	AE6	I	JTAG data in
TDO	AF5	O	JTAG data out
TRSTB	AE7	I	JTAG reset (active-low); pull down if JTAG is not used.
TMS	AF7	I	JTAG mode select
<b>SIGNALS (See mode selection guide for pin assignment)</b>			
TX[37:0]	AC8, AD8, AE8, AF8, AC9, AD9, AE9, AF9, AC10, AD10, AE10, AF10, AC11, AD11, AE11, AF11, AE12, AF12, AE13, AF13, AF15, AE15, AD15, AC15, AF16, AE16, AD16, AC16, AF17, AE17, AD17, AC17, AF18, AE18, AD18, AC18, AF19, AE19	O	Transmit to DAC(s)
FB[35:0]	A11, B11, C11, D11, A12, B12, C12, D12, A14, B14, A15, B15, C15, D15, A16, B16, C16, D16, A17, B17, A18, B18, C18, D18, A19, B19, A20, B20, C20, D20, A21, B21, C21, D21, A22, B22	I	Feedback from ADC(s)
NC	Y26, W24, W25, W26, V24, V25, V26, U25, U26, T24, T25, T26, R24, R25, P25, P26, N25, N26, M24, M25, M26, L24, L25, L26, K25, K26, J24, J25, H25, H26, D22, C22	–	No connect

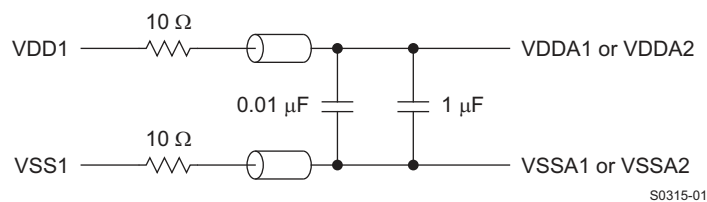
**Figure 1. GC5325 PLL Power Supply Filter**

The two PLLs require an analog supply. These can be generated by filtering the core digital supply (Vdd). A representative filter is shown in [Figure 1](#). The two PLLs should have separate filters and be located as close as reasonable to their respective pins (especially the bypass capacitors). The ferrite beads should be series 50R (similar to Murata P/N: BLM31P500SPT Description: IND FB BLM31P500SPT 50R 1206). In particular, supply VDDA1 must be less than or equal to VDD1 when VDD1 is at the low end of the required range. The series resistor assures this condition is met.



**Table 2. GC5325 TX Interface Options**

PIN FUNCTION	PIN NAME	I/O	DESCRIPTION
<b>TX (Single-Channel HSTL)</b>			
DAC[15:0]P	TX10, TX6, TX2, TX0, TX4, TX8, TX12, TX16, TX23, TX27, TX31, TX35, TX32, TX36, TX29, TX25	O	DAC positive output
DAC[15:0]N	TX11, TX7, TX3, TX1, TX5, TX9, TX13, TX17, TX22, TX26, TX30, TX34, TX33, TX37, TX28, TX24	O	DAC negative output
DACCLK	TX21	O	Clock to DAC
DACCLKC	TX20	O	Complementary clock to DAC
DACSYNCP	TX14	O	Positive output data sync
DACSYNCN	TX15	O	Negative output data sync

**Table 3. GC5325 FB Interface Options**

PIN FUNCTION	PIN NAME	I/O	DESCRIPTION
<b>Feedback (Single-Channel SDR LVDS or DDR LVDS)</b>			
ADC[15:0]P	FB2, FB4, FB6, FB8, FB10, FB12, FB14, FB16, FB20, FB22, FB24, FB26, FB28, FB30, FB32, FB34	I	ADC positive feedback from PA output
ADC[15:0]N	FB3, FB5, FB7, FB9, FB11, FB13, FB15, FB17, FB21, FB23, FB25, FB27, FB29, FB31, FB33, FB35	I	ADC negative feedback from PA output
ADCCLK	FB0	I	Clock from ADC
ADCLKC	FB1	I	Complementary clock from ADC
<b>Feedback (Single- or Dual-Channel DDR LVDS)</b>			
ADCA[7:0]P	FB2, FB4, FB6, FB8, FB10, FB12, FB14, FB16	I	ADC-A positive feedback from PA output
ADCA[7:0]N	FB3, FB5, FB7, FB9, FB11, FB13, FB15, FB17	I	ADC-A negative feedback from PA output
ADCACLK	FB0	I	Clock from ADC-A
ADCACLKC	FB1	I	Complementary clock from ADC-A
ADCB[7:0]P	FB20, FB22, FB24, FB26, FB28, FB30, FB32, FB34	I	ADC-B positive feedback from PA output
ADCB[7:0]N	FB21, FB23, FB25, FB27, FB29, FB31, FB33, FB35	I	ADC-B negative feedback from PA output
ADCBCLK	FB18	I	Clock from ADC-B
ADCBCLKC	FB19	I	Complementary clock from ADC-B

## MPU Interface Guidelines

The following section describes the hardware interface between the recommended microprocessor, external memory, and the GC5325. Users may select a microprocessor that meets their specific system requirements. Although the hardware can support multiple options, the recommended TMS320C6727 DSP is also fully supported with host control and adaptation software. [Figure 2](#) illustrates the hardware interface between the DSP to GC5325 and SDRAM. The external memory is required to accommodate the computational efforts of the adaptation algorithm. Although the system evaluation kit suggests dual parallel 64-Mb/PC133 (128-Mb) memory modules provided by Samsung (K4S641632H-TC(L)75), other memory alternatives are available. The processing speed or convergence time of the adaptation algorithm is not strictly limited by the external memory speed rating. The use of an external inverter, with minimal propagation delay, is required for OEB of the GC5325; this device is necessary when using a TMS320C6727 DSP. Additional documentation for the hardware interface is available in the *Hardware Designer's Resource Guide* application report ([SPRAA87](#)) and *TMS320C672x DSP External Memory Interface (EMIF) user's guide* ([SPRU711](#)).

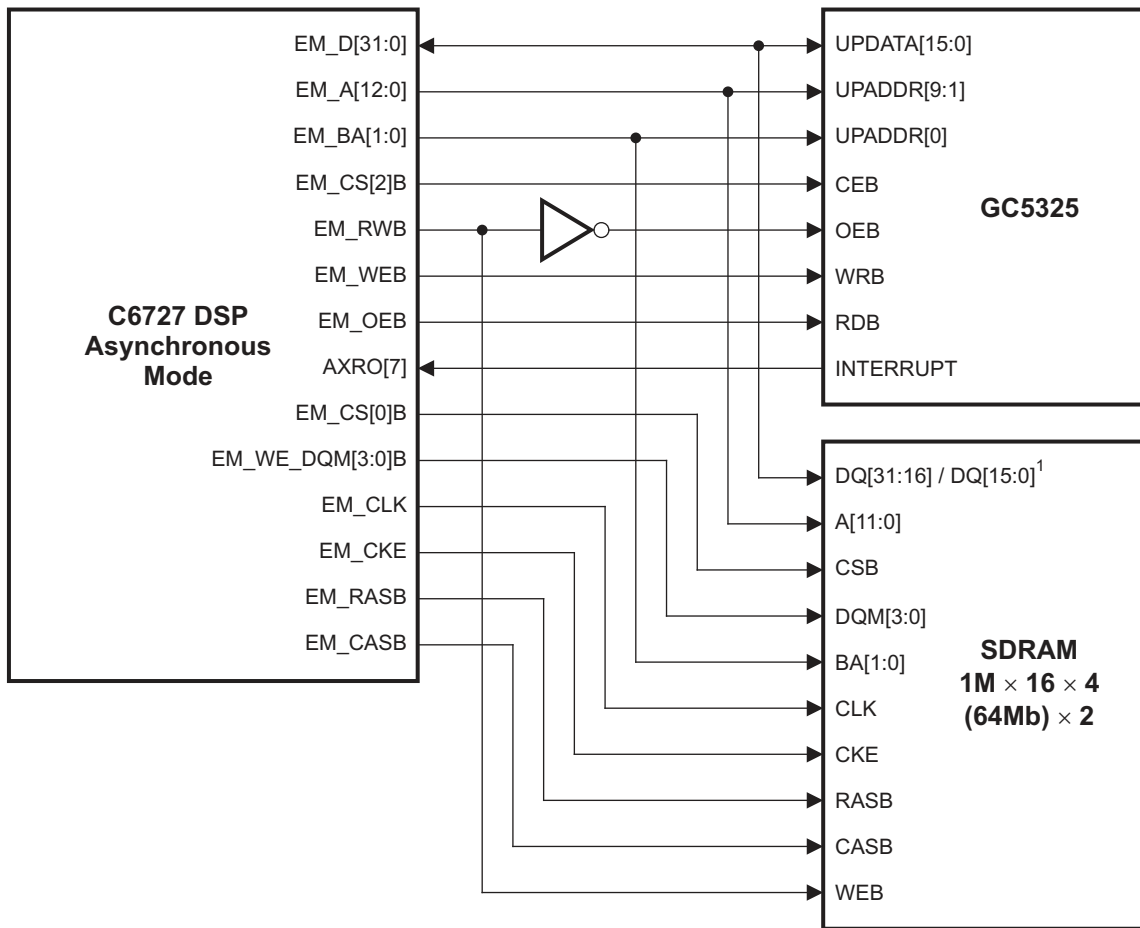

NOTE: Dual SDRAM modules are used, upper and lower EMIF data lines are split to access each respective memory module.

**Figure 2. DSP to GC5325/SDRAM Interface Specifications**

In a typical implementation, the system configuration software resides locally (in nonvolatile memory) to ensure proper operation at power up. The adaptation algorithm should also reside in the same location; at power up, the host should transfer/load the software from the nonvolatile memory (FLASH) to the 'C6727 DSP. The size of the software required to support the GC5325 and 'C6727 should be no more than 128 Mb (16 MB); however, this allocation is subject to change pending algorithm improvements. The suggested host-to-DSP interface is through the UHPI port. See [Chapter 0](#).

The port can be configured into multiple modes of data transfer; the *Multiplexed Host Address/Data Dual Halfword Mode* is suggested for this application.

Additional specifications and documents for the TMS320C6727 DSP are available from Texas Instruments at:

<http://focus.ti.com/docs/prod/folders/print/tms320c6727b.html>.

### Typical Baseband Interface

The GC5325 baseband interface receives time-interleaved I and Q data for each channel over the 16- or 18-bit input bus. The BB[15..0] bus is the 16-bit interface or the top 16 bits of the 18-bit interface. The frame strobe BBFS signal is used to identify the first channel I data. The data is input in channel order, I then Q. The baseband clock is used to register the interleaved IQ data and frame strobe.

The hardware sync signals SyncA, SyncB, and SyncC are used to time-align internal GC5325 operations. A 0-to-1 transition clocked by BBCKlock is an active sync signal.

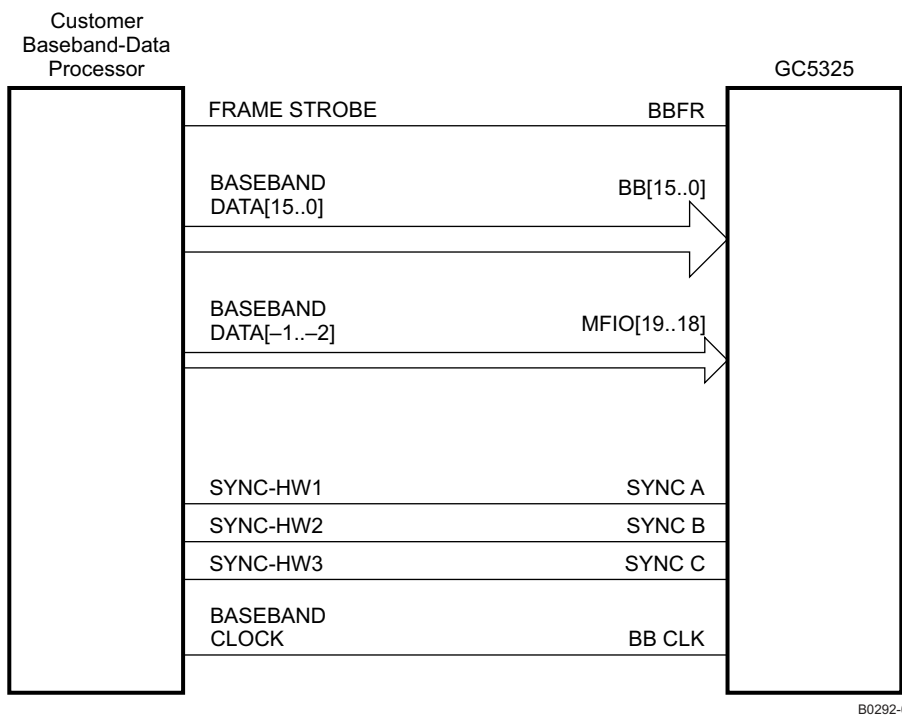

Figure 3. Typical Baseband Interface

## GENERAL SPECIFICATIONS

### ABSOLUTE MAXIMUM RATINGS

		VALUE	UNIT
$V_{DD}, V_{DDA}$	Core supply voltage	-0.3 to 1.32	V
$V_{DDS}$	Digital supply voltage for TX	-0.3 to 2	V
$V_{DDSHV}$	Digital supply voltage	-0.3 to 3.6	V
$V_{IN}$	Input voltage (under/overshoot)	-0.5 to $V_{DDSHV} + 0.5$	V
	Clamp current for an input/output	-20 to 20	mA
$T_{stg}$	Storage temperature	-65 to 150	°C
	Lead soldering temperature, 10 seconds	300	°C
	ESD Classification Class 2 (Required 2-kV HBM, 500-V CDM) (Passed 2.5-kV HBM, 500-V CDM, 200-V MM)		
	Moisture sensitivity Class 3 (1 week floor life at 30°C/60% H)		
	Reflow conditions JEDEC standard	260	= C

## RECOMMENDED OPERATING CONDITIONS

over operating free-air temperature range (unless otherwise noted)

			MIN	TYP	MAX	UNIT
$V_{DD}$ , $V_{DDA2}$ , $V_{PP}$	Core supply voltages. Note $V_{DDA2} \leq V_{DD}$		1.14	1.2	1.26	V
$V_{DDA1}$	Analog supply for DPD PLL	See <sup>(1)</sup>	1	1.1	VDD	V
$V_{DDS}$	Digital supply voltage for TX		1.71	1.8	1.89	V
$V_{DDSHV}$	Digital supply voltage		3.15	3.3	3.45	V
$I_{DD}$ , $I_{DDA1}$ , $I_{DDA2}$ , $I_{PP}$	Combined supply current for Vdd, Vdda1, Vdda2, and Vpp				3	A
$I_{DDS}$	Digital supply current for TX				0.25	A
$I_{DDSHV}$	Digital supply current				0.3	A
$T_C$	Case temperature	See <sup>(2)</sup>	-40	30	85	°C
$T_J$	Junction temperature	See <sup>(3)</sup>			105	°C

(1) VDDA1 must be less than VDD1 when VDD1 is low. See recommended filtering circuit in [Figure 1](#). Maximum observed current on VDDA1 is 8 mA.

(2) Chip specifications in are production tested to 90°C case temperature. QA tests are performed at 85°C.

(3) Thermal management may be required for full-rate operation. Sustained operation at elevated temperatures reduces long-term reliability. Lifetime calculations based on maximum junction temperature of 105°C.

## THERMAL CHARACTERISTICS

PARAMETER		352 BGA at 4 W	UNITS
$R_{\theta JA}$	Thermal resistance, junction-to-ambient (still air)	15	°C/W
$R_{\theta JMA1}$	Theta junction to ambient (1 m/s)	11.8	°C/W
$R_{\theta JC}$	Thermal resistance, junction-to-case	0.92	°C/W
$R_{\theta JB}$	Thermal resistance, junction-to-board	5.3	°C/W

## GENERAL ELECTRICAL CHARACTERISTICS

Describes the electrical characteristics for the baseband interface, multifunction I/O (MFIO), DPD clock and fast sync, MPU and JTAG interfaces over recommended operating conditions. Device is production tested at 90 = C for the given specification and characterized at –40 = C (unless otherwise noted).

PARAMETER		TEST CONDITIONS	MIN	TYP	MAX	UNIT
<b>CMOS INTERFACE</b>						
V <sub>IL</sub>	CMOS voltage input, low				0.8	V
V <sub>IH</sub>	CMOS voltage input, high		2		V <sub>DDSHV</sub>	V
V <sub>OL</sub>	CMOS voltage output, low	I <sub>OL</sub> = 2 mA			0.5	V
V <sub>OH</sub>	CMOS voltage output, high	I <sub>OH</sub> = –2 mA	2.4		V <sub>DDSHV</sub>	V
I <sub>PUL</sub>	Pullup current	V <sub>IN</sub> = 0 V	40	100	200	μA
I <sub>IN</sub>	Leakage current	V <sub>IN</sub> = 0 or V <sub>IN</sub> = V <sub>DDSHV</sub>			5	μA
<b>DAC INTERFACE (DAC P/N[15:0])</b>						
V <sub>O(diff)</sub>	Output differential swing,  V <sub>O(diff)</sub>   =  V <sub>OH</sub> – V <sub>OL</sub>	(1)	250			mV
V <sub>(COMM)</sub>	Common mode voltage, (V <sub>OH</sub> + V <sub>OL</sub> )/2	(1)	1000			mV
<b>LVDS INTERFACE (FB[35:0], DPDCLK/C, SYNCDC/C)</b>						
V <sub>i</sub>	Input voltage range		0		2000	mV
V <sub>i(diff)</sub>	Input differential voltage,  V <sub>pos</sub> – V <sub>neg</sub>	0 < V <sub>i</sub> < 2000 mV	250			mV
		1000 mV < V <sub>i</sub> < 1400 mV, FB[35:0] only	90			
R <sub>IN</sub>	Input differential impedance		80		120	Ω
<b>POWER SUPPLY</b>						
I <sub>dyn</sub>	Core current	See <sup>(2)</sup>			2.2	A

- (1) HSTL output levels are measured at 675 Mb/s delay and with 100-Ω load from P to N. Drive strength set to 0x360. Contact TI for operations above 675 Mb/s.  
 (2) Operating at 280 MHz core, 840 TX port, maximum filtering, nominal supplies

## GENERAL SWITCHING CHARACTERISTICS

Describes the electrical characteristics for the baseband interface, MFIO, Fast Sync, and MPU interfaces over recommended operating conditions (unless otherwise noted)

PARAMETER	TEST CONDITIONS	MIN	MAX	UNIT
<b>BASEBAND INTERFACE</b>				
$f_{CLK(BB)}$	Baseband input clock frequency	25	140	MHz
$t_{su(BB)}$	Input data setup time before BBCLK $\uparrow$	1.3		ns
$t_{h(BB)}$	Input data hold time after BBCLK $\uparrow$	1.5		ns
$t_{h(SYNCA, -B, -C)}$	Input data hold time after BBCLK $\uparrow$	2		ns
Duty $_{CLK(BB)}$	Duty cycle	30%	70%	
$t_{CLK(BB)}$	Baseband input clock cycle-to-cycle jitter <sup>(1)</sup>	-2.5%	2.5%	

(1) Percent of baseband PLL clock period. The baseband PLL clock is typically 2x–4x the baseband clock frequency.

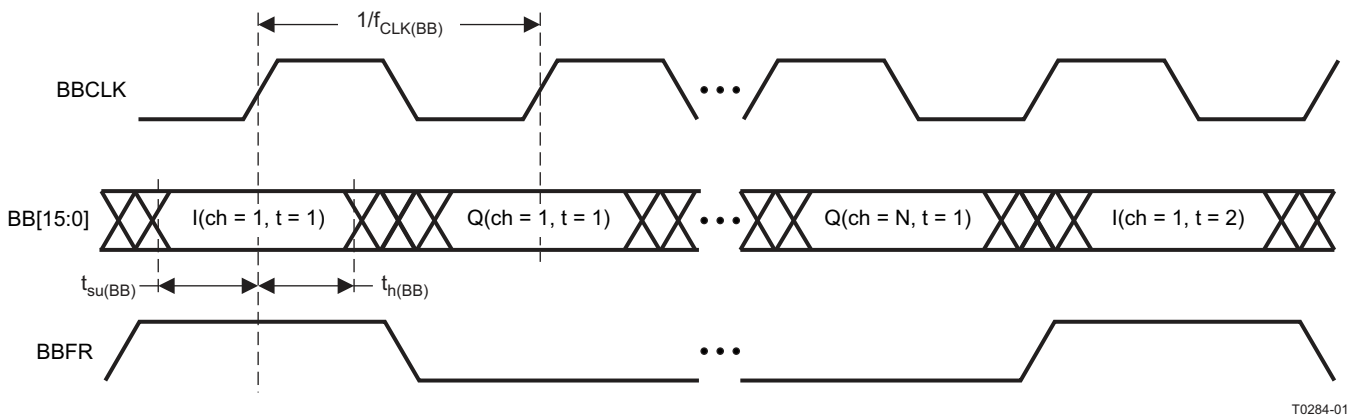
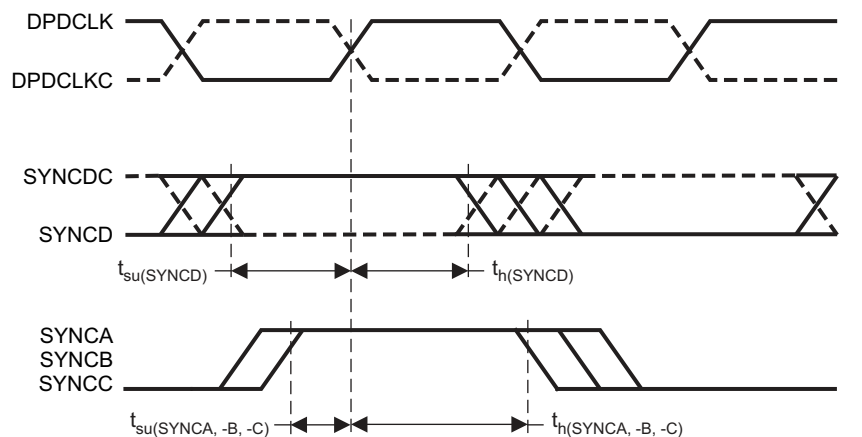

**Figure 4. Baseband Timing Specifications (ex. Four Interleaved I/Q Channels)**

**Table 12. DPD CLOCK AND FAST SYNC SWITCHING CHARACTERISTICS**

PARAMETER	TEST CONDITIONS	MIN	MAX	UNIT
$f_{CLK(DPD)}$	DPD input clock frequency	100	280	MHz
$Duty_{CLK(DPD)}$	DPD input clock duty cycle	30%	70%	
$t_{h(SYNCD)}$	Input hold time after DPDCLK↑	See <sup>(1)</sup>		ns
$t_{su(SYNCD)}$	Input setup time after DPDCLK↑	See <sup>(1)</sup>		ns
$t_{h(SYNCA, -B, -C)}$	Input hold time after DPDCLK↑	2		ns
$t_{su(SYNCA, -B, -C)}$	Input setup time after DPDCLK↑	0.4		ns
$t_{jCLK(DPD)}$	DPD clock cycle-to-cycle jitter	-2.5%	2.5%	

(1) SYNCD is the preferred sync for DPD clock and clock domain.

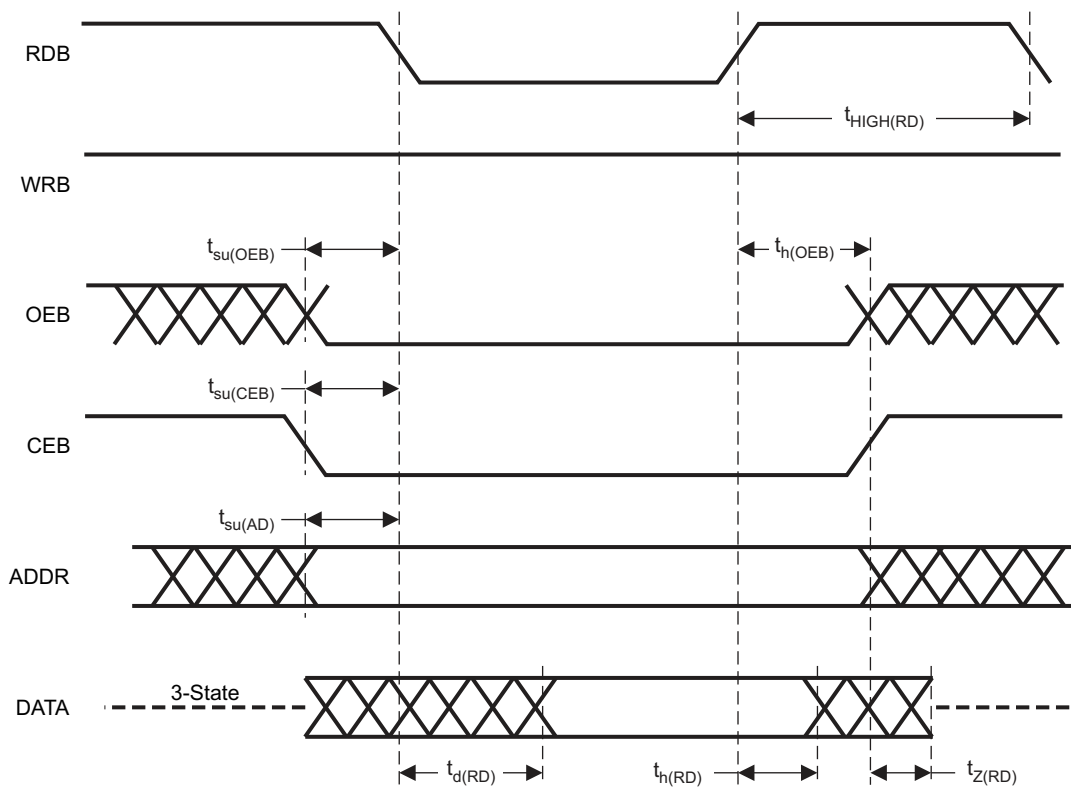

**Figure 5. DPD Clock and Fast Sync Timing Specifications**

### MPU SWITCHING CHARACTERISTICS (READ)

PARAMETER		TEST CONDITIONS	MIN	MAX	UNIT
$t_{su(AD)}$	ADDR setup time to RDB↓	WRB is HIGH.	5		ns
$t_{su(CEB)}$	CEB setup time to RDB↓	WRB is HIGH.	7		ns
$t_{su(OEB)}$	OEB setup time to RDB↓	WRB is HIGH.	2		ns
$t_{d(RD)}$	DATA valid time after RDB↓	WRB is HIGH.		14	ns
$t_{h(RD)}$	ADDR hold time to RDB↑	WRB is HIGH.	2		ns
	OEB, CEB hold time to RDB↑		0		
	OEB hold time to RDB↑		2		
$t_{HIGH(RD)}$	Time RDB must remain HIGH between READs.	WRB is HIGH <sup>(1)</sup> .	7		ns
$t_{Z(RD)}$	DATA goes high-impedance after OEB↑ or RDB↑.	WRB is HIGH <sup>(1)</sup> .		7	ns

(1) Controlled by design and process and not directly tested



T0287-01

Figure 6. MPU READ Timing Specifications



**MPU SWITCHING CHARACTERISTICS (WRITE)**

PARAMETER		TEST CONDITIONS	MIN	MAX	UNIT
$t_{su(WR)}$	DATA and ADDR setup time to WRB $\downarrow$	OEB and RDB are HIGH.	5		ns
	CEB setup time to WRB $\downarrow$		7		
	OEB setup time to WRB $\downarrow$		2		
$t_{h(WR)}$	DATA and ADDR hold time after WRB $\uparrow$	OEB and RDB are HIGH.	2		ns
	OEB and CEB hold time after WRB $\uparrow$		0		
$t_{low(WR)}$	Time WRB and CEB must remain simultaneously LOW	OEB and RDB are HIGH.	15		ns
$t_{high(WR)}$	Time CEB or WRB must remain HIGH between WRITES.	OEB and RDB are HIGH.	10		ns

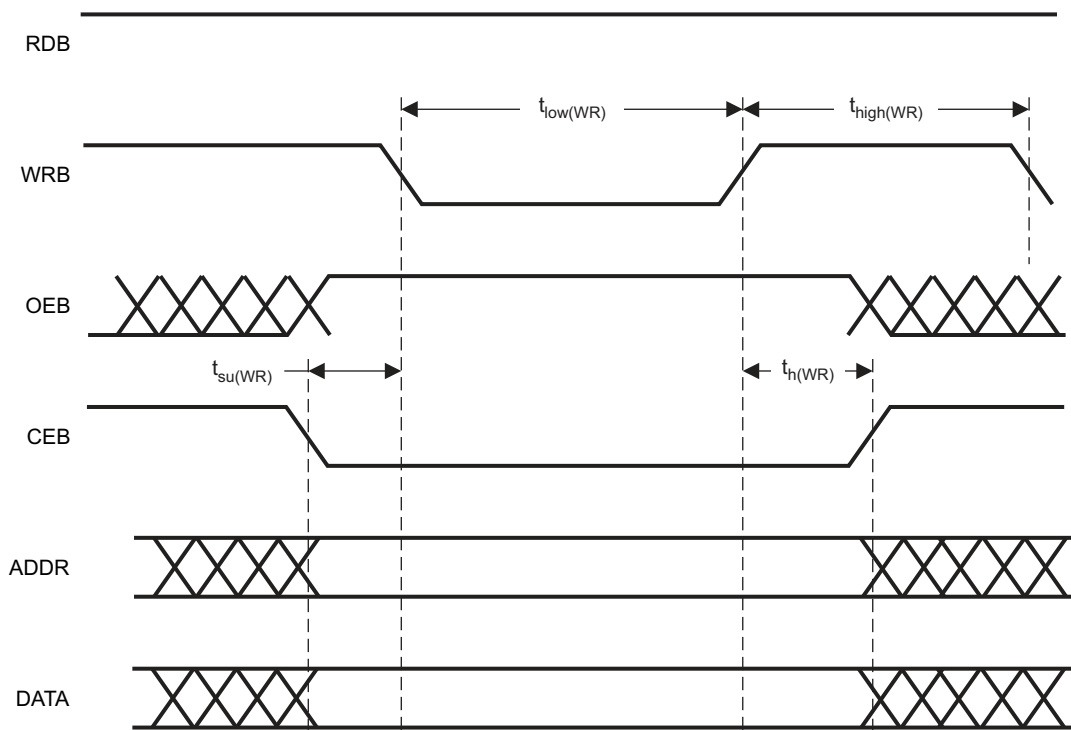

T0288-01

**Figure 7. MPU WRITE Timing Specifications**

### JTAG SWITCHING CHARACTERISTICS

PARAMETER		TEST CONDITIONS	MIN	MAX	UNIT
$f_{TCK}$	JTAG clock frequency			50	MHz
$t_{p(TCKL)}$	JTAG clock low period		10		ns
$t_{p(TCKH)}$	JTAG clock high period		10		ns
$t_{su(TDI)}$	Input data setup time before TCK $\uparrow$	Valid for TDI and TMS	1		ns
$t_h(TDI)$	Input data hold time after TCK $\uparrow$	Valid for TDI and TMS	6		ns
$t_d(TDO)$	Output data delay from TCK $\downarrow$			8	ns

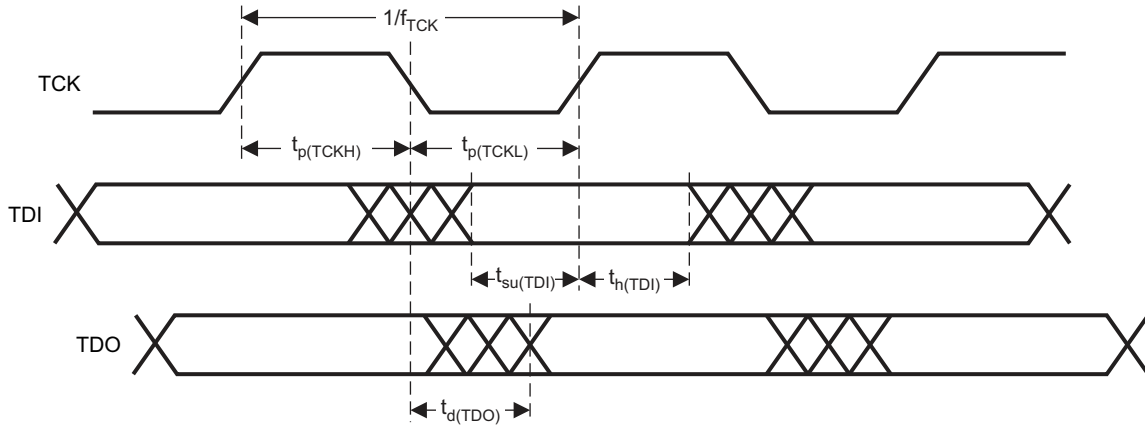

T0289-01

Figure 8. JTAG Timing Specifications

### ELECTRICAL CHARACTERISTICS

#### TX SWITCHING CHARACTERISTICS

over recommended operating conditions (unless otherwise noted)

PARAMETER	TEST CONDITIONS	MIN	TYP	MAX	UNIT
<b>HSTL MODE – DDR ex. DAC5682</b>					
$f_{CLK(DAC)}$	DAC output clock frequency	$R_L = 100 \Omega$ <sup>(1)</sup>		420	MHz

(1) Because the output clock is DDR, this represents 840 MSPS real or 420 MSPS complex.

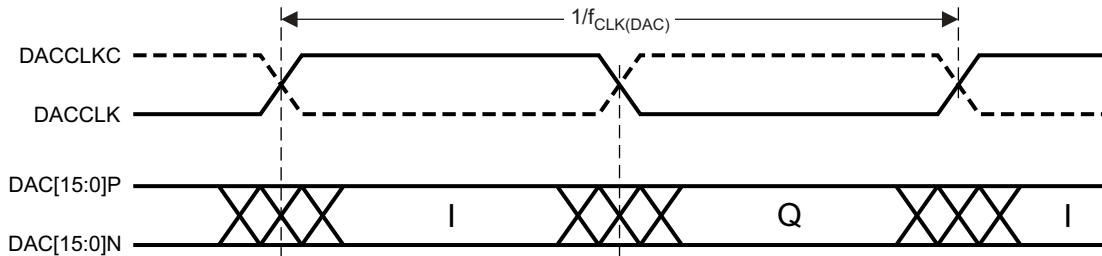

T0290-02

Figure 9. TX Timing Specifications (HSTL – DDR)

## LVDS SWITCHING CHARACTERISTICS

Over recommended operating conditions (unless otherwise noted). The following table uses a shorthand nomenclature, NxM. N means the number of differential pairs used to transmit data from one ADC and M means the number of bits sent serially down each LVDS pair. Thus, 8x2 means 8 LVDS pairs each containing 2 bits of information sent serially.

PARAMETER	TEST CONDITIONS	MIN	TYP	MAX	UNIT
<b>16x1 SDR LVDS MODE ex. ADS5444</b>					
$f_{CLK(ADC)}$	ADC interface clock frequency	See (1)		280	MHz
$t_{su(ADC\{\#\}P)}$	Input data setup time before CLK $\uparrow$	See (1) (2)	300		ps
$t_h(ADC\{\#\}P)$	Input data hold time after CLK $\uparrow$	See (1) (2)	600		ps
<b>16x1 DDR LVDS MODE ex. ADS5463</b>					
$f_{CLK(ADC)}$	ADC interface clock frequency	See (1)		140	MHz
$t_{su(ADC\{\#\}P)}$	Input data setup time before CLK $\uparrow\downarrow$	See (1) (2)	100		ps
$t_h(ADC\{\#\}P)$	Input data hold time after CLK $\uparrow\downarrow$	See (1) (2)	1200		ps
<b>8x2 DDR LVDS MODE ex. ADS5545</b>					
$f_{CLK(ADCA)}$	ADCA interface clock frequency	See (1)		280	MHz
$t_{su(ADCA\{\#\}2P)}$	Input data setup time before CLK $\uparrow\downarrow$	See (1) (3). For port A	430		ps
$t_h(ADCA\{\#\}2P)$	Input data hold time after CLK $\uparrow\downarrow$	See (1) (3). For port A	260		ps
$f_{CLK(ADCB)}$	ADCB interface clock frequency	See (1)		280	MHz
$t_{su(ADCB\{\#\}2P)}$	Input data setup time before CLK $\uparrow\downarrow$	See (1) (4). For port B	800		ps
$t_h(ADCB\{\#\}2P)$	Input data hold time after CLK $\uparrow\downarrow$	See (1) (4). For port B	400		ps

- (1) Specifications are limited by GC5325 performance and may exceed the example ADC capabilities for the given interface.
- (2) Setup and hold measured for ADC[15:0]P, ADC[15:0]N valid for ( $V_{OD} > 250$  mV) to/from ADCCLK and ADCCLKC clock crossing ( $V_{OD} = 0$ ).
- (3) Setup and hold measured for ADCA[7:0]P, ADCA[7:0]N valid for ( $V_{OD} > 250$  mV) to/from ADCACLK and ADCACLKC clock crossing ( $V_{OD} = 0$ ).
- (4) Setup and hold measured for ADCB[7:0]P, ADCB[7:0]N valid for ( $V_{OD} > 250$  mV) to/from ADCBCLK and ADCBCLKC clock crossing ( $V_{OD} = 0$ ).

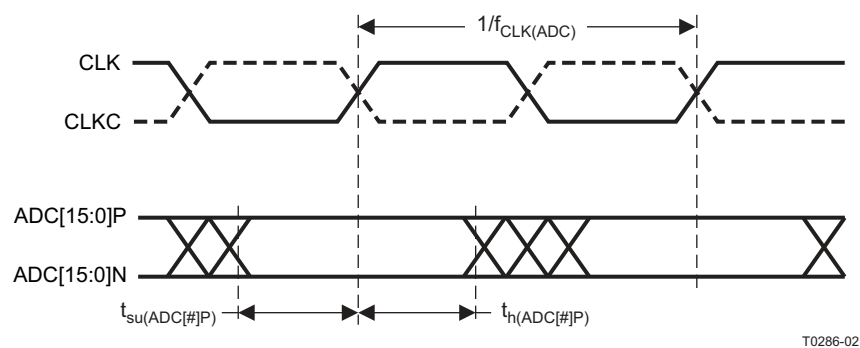

Figure 10. LVDS Timing Specifications (16 × 1 SDR LVDS)

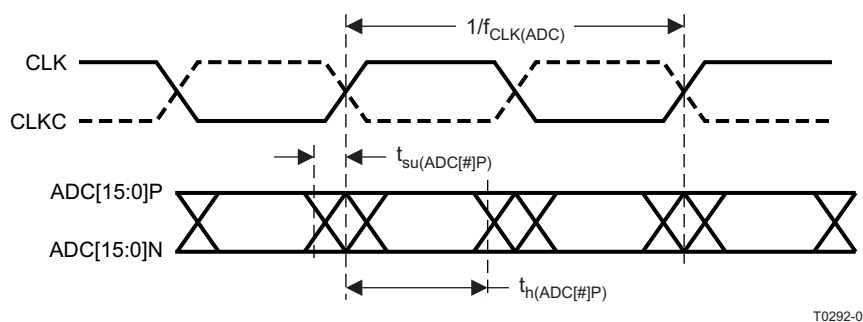
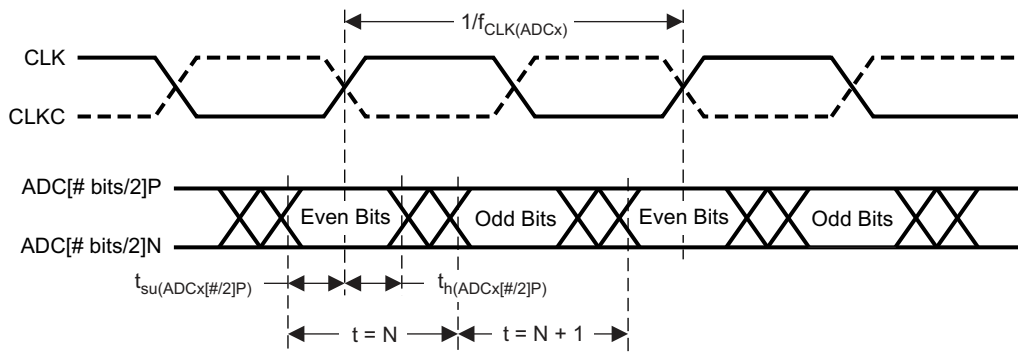

Figure 11. LVDS Timing Specifications (16 × 1 DDR LVDS)



T0293-01

Figure 12. LVDS Timing Specifications (8 × 2 DDR LVDS)

APPENDIX A

See the *TMS320C672x DSP Universal Host Port Interface (UHPI)* reference guide ([SPRU719](#)).

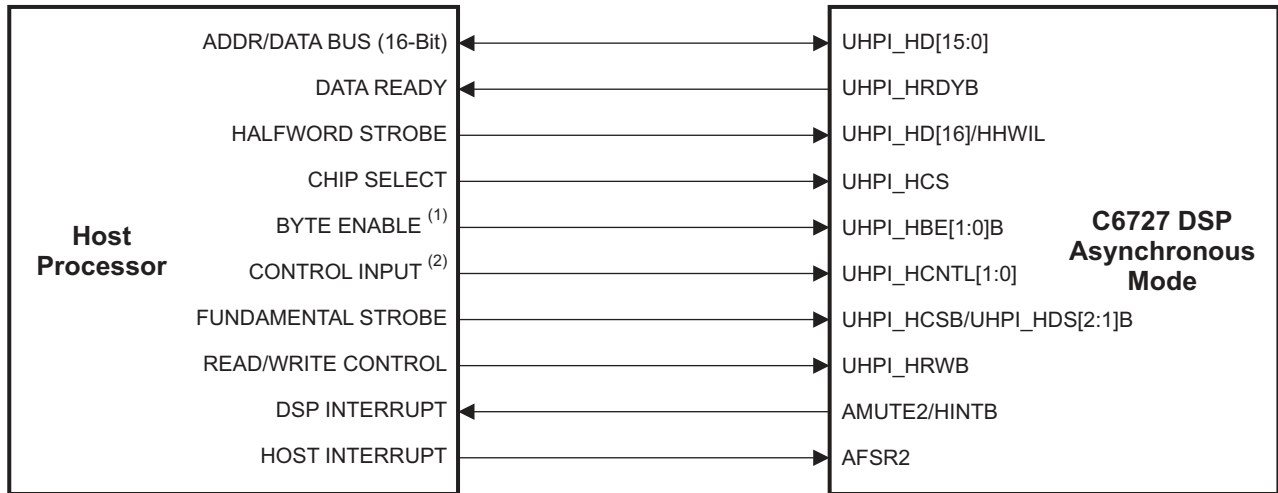

B0281-01

- (1) Byte enables are applicable to single HPID accesses. All byte enables must be active during HPID with post-increment (burst) UHPI accesses.
- (2) Control inputs selecting between HPIA, HPIC, HPID, and HPID with post-increment accesses.

Figure 13. Host-to-DSP Interface (Multiplexed Host Address/Data Dual Halfword)

GLOSSARY OF TERMS

- 3G Third generation (refers to next-generation wideband cellular systems that use CDMA)
- 3GPP Third generation partnership project (W-CDMA specification, [www.3gpp.org](http://www.3gpp.org))
- 3GPP2 Third generation partnership project 2 (cdma2000 specification, [www.3gpp2.org](http://www.3gpp2.org))
- ACLR Adjacent channel leakage ratio (measure of out-of-band energy from one CDMA carrier)
- ACPR Adjacent channel power ratio
- ADC Analog-to-digital converter
- BW Bandwidth

CCDF	Complementary cumulative distribution function
CDMA	Code division multiple access (spread spectrum)
CEVM	Composite error vector magnitude
CFR	Crest factor reduction
CMOS	Complementary metal oxide semiconductor
DAC	Digital-to-analog converter
dB	Decibels
dBm	Decibels relative to 1 mW (30 dBm = 1 W)
DDR	Dual data rate (ADC output format)
DSP	Digital signal processing or digital signal processor
EVM	Error vector magnitude
FIR	Finite impulse response (type of digital filter)
I/Q	In-phase and quadrature (signal representation)
IF	Intermediate frequency
IIR	Infinite impulse response (type of digital filter)
JTAG	Joint Test Action Group (chip debug and test standard 1149.1)
LO	Local oscillator
LSB	Least-significant bit
Mb	Megabits (divide by 8 for megabytes MB)
MSB	Most-significant bit
MSPS	Megasamples per second ( $1 \times 10^6$ samples/s)
PA	Power amplifier
PAR	Peak-to-average ratio
PCDE	Peak code domain error
PDC	Peak detection and cancellation (stage)
PDF	Probability density function
RF	Radio frequency
RMS	Root mean square (method to quantify error)
SDR	Single data rate (ADC output format)
SEM	Spectrum emission mask
SNR	Signal-to-noise ratio (usually measured in dB or dBm)
UMTS	Universal mobile telephone service
W-CDMA	Wideband code division multiple access (synonymous with 3GPP)
WiBRO	Wireless broadband (Korean initiative IEEE 802.16e)
WiMAX	Worldwide Interoperability of Microwave Access (IEEE 802.16e)

**PACKAGING INFORMATION**

Orderable Device	Status <sup>(1)</sup>	Package Type	Package Drawing	Pins	Package Qty	Eco Plan <sup>(2)</sup>	Lead/Ball Finish	MSL Peak Temp <sup>(3)</sup>
GC5325IZND	ACTIVE	BGA	ZND	352	40	Pb-Free (RoHS)	SNAGCU	Level-3-260C-168 HR

<sup>(1)</sup> The marketing status values are defined as follows:

**ACTIVE:** Product device recommended for new designs.

**LIFEBUY:** TI has announced that the device will be discontinued, and a lifetime-buy period is in effect.

**NRND:** Not recommended for new designs. Device is in production to support existing customers, but TI does not recommend using this part in a new design.

**PREVIEW:** Device has been announced but is not in production. Samples may or may not be available.

**OBSOLETE:** TI has discontinued the production of the device.

<sup>(2)</sup> Eco Plan - The planned eco-friendly classification: Pb-Free (RoHS), Pb-Free (RoHS Exempt), or Green (RoHS & no Sb/Br) - please check <http://www.ti.com/productcontent> for the latest availability information and additional product content details.

**TBD:** The Pb-Free/Green conversion plan has not been defined.

**Pb-Free (RoHS):** TI's terms "Lead-Free" or "Pb-Free" mean semiconductor products that are compatible with the current RoHS requirements for all 6 substances, including the requirement that lead not exceed 0.1% by weight in homogeneous materials. Where designed to be soldered at high temperatures, TI Pb-Free products are suitable for use in specified lead-free processes.

**Pb-Free (RoHS Exempt):** This component has a RoHS exemption for either 1) lead-based flip-chip solder bumps used between the die and package, or 2) lead-based die adhesive used between the die and leadframe. The component is otherwise considered Pb-Free (RoHS compatible) as defined above.

**Green (RoHS & no Sb/Br):** TI defines "Green" to mean Pb-Free (RoHS compatible), and free of Bromine (Br) and Antimony (Sb) based flame retardants (Br or Sb do not exceed 0.1% by weight in homogeneous material)

<sup>(3)</sup> MSL, Peak Temp. -- The Moisture Sensitivity Level rating according to the JEDEC industry standard classifications, and peak solder temperature.

**Important Information and Disclaimer:**The information provided on this page represents TI's knowledge and belief as of the date that it is provided. TI bases its knowledge and belief on information provided by third parties, and makes no representation or warranty as to the accuracy of such information. Efforts are underway to better integrate information from third parties. TI has taken and continues to take reasonable steps to provide representative and accurate information but may not have conducted destructive testing or chemical analysis on incoming materials and chemicals. TI and TI suppliers consider certain information to be proprietary, and thus CAS numbers and other limited information may not be available for release.

In no event shall TI's liability arising out of such information exceed the total purchase price of the TI part(s) at issue in this document sold by TI to Customer on an annual basis.

# MECHANICAL DATA

ZND (S-PBGA-N352)

PLASTIC BALL GRID ARRAY (CAVITY DOWN)

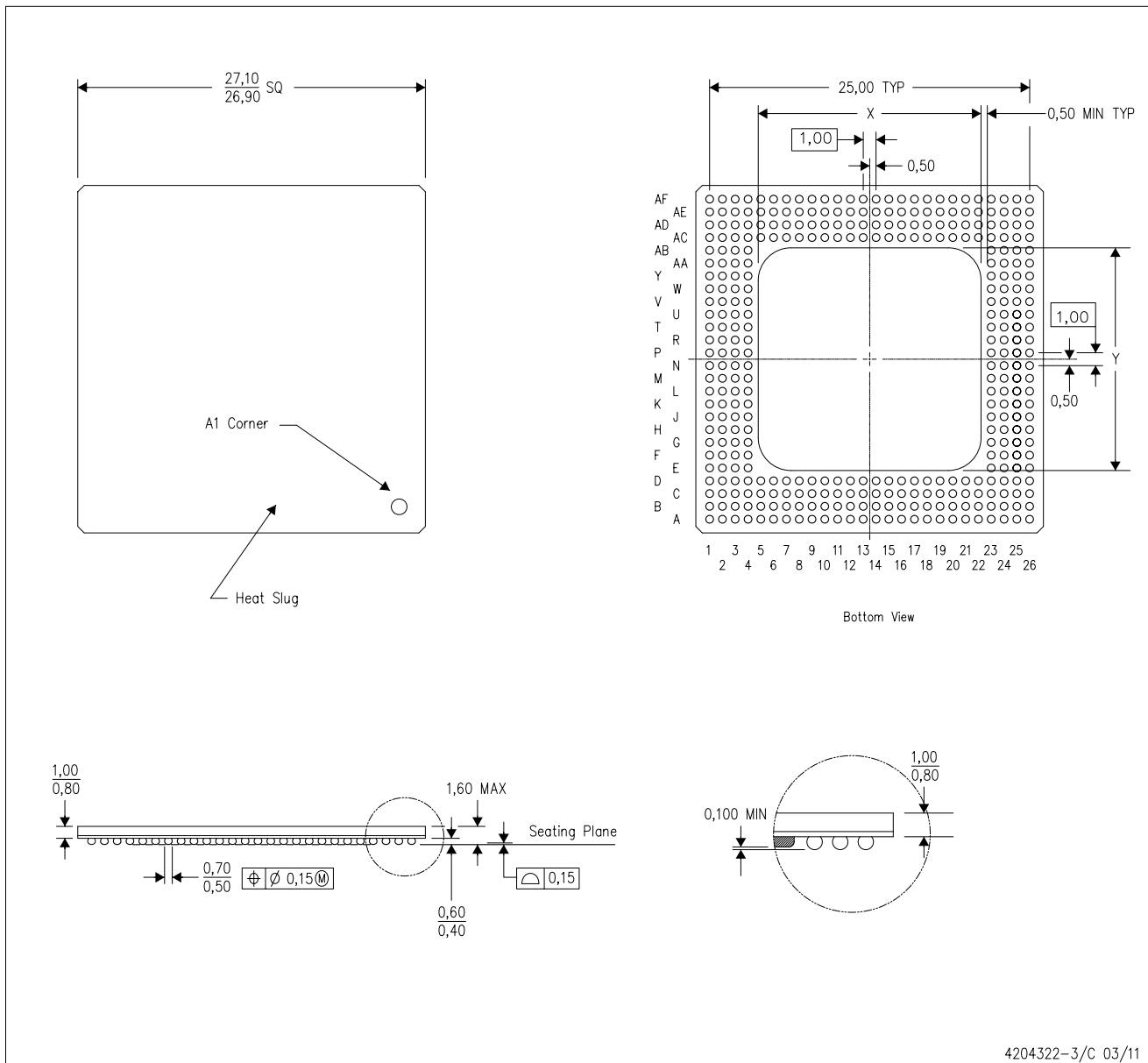

- NOTES:
- All linear dimensions are in millimeters. Dimensioning and tolerancing per ASME Y14.5M-1994.
  - This drawing is subject to change without notice.
  - Thermally enhanced plastic package with heat slug (HSL).
  - The encapsulation size (X,Y) will vary with cavity size. The distance from bond finger edge to encapsulation shall be min 0.5mm
  - This is a Pb-free solder ball design.

## IMPORTANT NOTICE

Texas Instruments Incorporated and its subsidiaries (TI) reserve the right to make corrections, modifications, enhancements, improvements, and other changes to its products and services at any time and to discontinue any product or service without notice. Customers should obtain the latest relevant information before placing orders and should verify that such information is current and complete. All products are sold subject to TI's terms and conditions of sale supplied at the time of order acknowledgment.

TI warrants performance of its hardware products to the specifications applicable at the time of sale in accordance with TI's standard warranty. Testing and other quality control techniques are used to the extent TI deems necessary to support this warranty. Except where mandated by government requirements, testing of all parameters of each product is not necessarily performed.

TI assumes no liability for applications assistance or customer product design. Customers are responsible for their products and applications using TI components. To minimize the risks associated with customer products and applications, customers should provide adequate design and operating safeguards.

TI does not warrant or represent that any license, either express or implied, is granted under any TI patent right, copyright, mask work right, or other TI intellectual property right relating to any combination, machine, or process in which TI products or services are used. Information published by TI regarding third-party products or services does not constitute a license from TI to use such products or services or a warranty or endorsement thereof. Use of such information may require a license from a third party under the patents or other intellectual property of the third party, or a license from TI under the patents or other intellectual property of TI.

Reproduction of TI information in TI data books or data sheets is permissible only if reproduction is without alteration and is accompanied by all associated warranties, conditions, limitations, and notices. Reproduction of this information with alteration is an unfair and deceptive business practice. TI is not responsible or liable for such altered documentation. Information of third parties may be subject to additional restrictions.

Resale of TI products or services with statements different from or beyond the parameters stated by TI for that product or service voids all express and any implied warranties for the associated TI product or service and is an unfair and deceptive business practice. TI is not responsible or liable for any such statements.

TI products are not authorized for use in safety-critical applications (such as life support) where a failure of the TI product would reasonably be expected to cause severe personal injury or death, unless officers of the parties have executed an agreement specifically governing such use. Buyers represent that they have all necessary expertise in the safety and regulatory ramifications of their applications, and acknowledge and agree that they are solely responsible for all legal, regulatory and safety-related requirements concerning their products and any use of TI products in such safety-critical applications, notwithstanding any applications-related information or support that may be provided by TI. Further, Buyers must fully indemnify TI and its representatives against any damages arising out of the use of TI products in such safety-critical applications.

TI products are neither designed nor intended for use in military/aerospace applications or environments unless the TI products are specifically designated by TI as military-grade or "enhanced plastic." Only products designated by TI as military-grade meet military specifications. Buyers acknowledge and agree that any such use of TI products which TI has not designated as military-grade is solely at the Buyer's risk, and that they are solely responsible for compliance with all legal and regulatory requirements in connection with such use.

TI products are neither designed nor intended for use in automotive applications or environments unless the specific TI products are designated by TI as compliant with ISO/TS 16949 requirements. Buyers acknowledge and agree that, if they use any non-designated products in automotive applications, TI will not be responsible for any failure to meet such requirements.

Following are URLs where you can obtain information on other Texas Instruments products and application solutions:

### Products

Audio	<a href="http://www.ti.com/audio">www.ti.com/audio</a>
Amplifiers	<a href="http://amplifier.ti.com">amplifier.ti.com</a>
Data Converters	<a href="http://dataconverter.ti.com">dataconverter.ti.com</a>
DLP® Products	<a href="http://www.dlp.com">www.dlp.com</a>
DSP	<a href="http://dsp.ti.com">dsp.ti.com</a>
Clocks and Timers	<a href="http://www.ti.com/clocks">www.ti.com/clocks</a>
Interface	<a href="http://interface.ti.com">interface.ti.com</a>
Logic	<a href="http://logic.ti.com">logic.ti.com</a>
Power Mgmt	<a href="http://power.ti.com">power.ti.com</a>
Microcontrollers	<a href="http://microcontroller.ti.com">microcontroller.ti.com</a>
RFID	<a href="http://www.ti-rfid.com">www.ti-rfid.com</a>
RF/IF and ZigBee® Solutions	<a href="http://www.ti.com/lprf">www.ti.com/lprf</a>

### Applications

Communications and Telecom	<a href="http://www.ti.com/communications">www.ti.com/communications</a>
Computers and Peripherals	<a href="http://www.ti.com/computers">www.ti.com/computers</a>
Consumer Electronics	<a href="http://www.ti.com/consumer-apps">www.ti.com/consumer-apps</a>
Energy and Lighting	<a href="http://www.ti.com/energy">www.ti.com/energy</a>
Industrial	<a href="http://www.ti.com/industrial">www.ti.com/industrial</a>
Medical	<a href="http://www.ti.com/medical">www.ti.com/medical</a>
Security	<a href="http://www.ti.com/security">www.ti.com/security</a>
Space, Avionics and Defense	<a href="http://www.ti.com/space-avionics-defense">www.ti.com/space-avionics-defense</a>
Transportation and Automotive	<a href="http://www.ti.com/automotive">www.ti.com/automotive</a>
Video and Imaging	<a href="http://www.ti.com/video">www.ti.com/video</a>
Wireless	<a href="http://www.ti.com/wireless-apps">www.ti.com/wireless-apps</a>

TI E2E Community Home Page

[e2e.ti.com](http://e2e.ti.com)

Mailing Address: Texas Instruments, Post Office Box 655303, Dallas, Texas 75265  
Copyright © 2011, Texas Instruments Incorporated