

ISL8120EVAL3Z

Evaluation Board Setup Procedure

AN1528  
Rev.2.00  
July 1, 2016

**Description**

The [ISL8120](#) integrates two voltage mode synchronous buck PWM controllers. It can be used either for dual independent outputs or a 2-phase single output regulator.

The ISL8120EVAL3Z evaluation board is for performance demo of the dual independent outputs and DDR applications.

The ISL8120EVAL4Z evaluation board is used for performance demo of 2/n-phase single-output applications. Refer to application note [AN1607](#) "ISL8120EVAL4Z Evaluation Board Setup Procedure" for details of the ISL8120EVAL4Z board.

**Preset Specifications**

VIN (V)	FREQUENCY (kHz)	VOUT1	VOUT2
12	500	1.2V/25A	1.2V/25A

**Recommended Equipment**

- 0V to 22V power supply with at least 20A source current capability, battery, or notebook AC adapter.
- Two electronic loads capable of sinking current up to 30A
- Digital Multimeters (DMMs).
- 100MHz quad-trace oscilloscope.

**References**

- [ISL8120](#) Datasheet
- [AN1607](#), "ISL8120EVAL4Z Evaluation Board Setup Procedure"

**Ordering Information**

PART NUMBER	DESCRIPTION
ISL8120EVAL3Z	ISL8120 evaluation board for performance evaluation

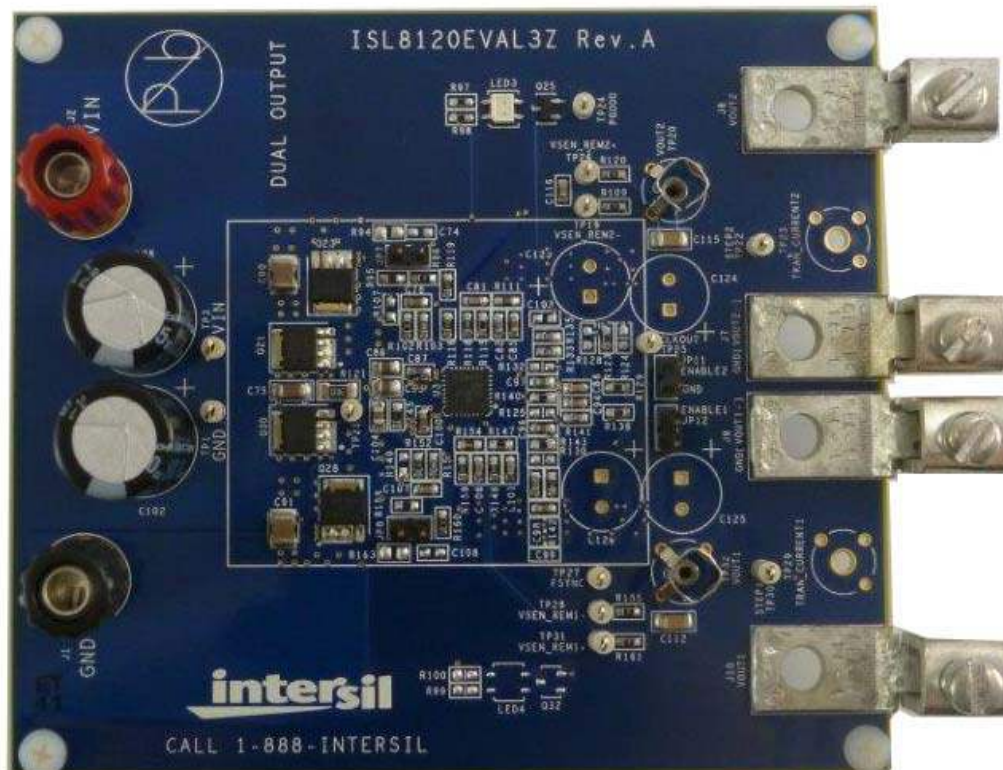

FIGURE 1. ISL8120EVAL3Z EVALUATION BOARD

## Circuits Description

J1 and J2 are the input power terminals.

Two input electrolytic capacitors are used to handle the input current ripples.

Two upper and two lower Renesas “speed” series LFPK MOSFETs are used for each channel. Q<sub>1</sub> and Q<sub>2</sub> are footprint options for low current applications where a S08 package integrating dual MOSFET can be used.

320nH PULSE surface mount inductors are used for each channel. Under the 500kHz setup, the inductor current peak-to-peak ripple is 7.5A at 12V input.

Two SANYO POSCAP 2R5TPF470M7L (7mΩ) are used as output E-caps for each channel. Also, through-hole electrolytic capacitor footprints C<sub>123</sub> ~ C<sub>126</sub> are available for the user to evaluate different output capacitors.

J7, J8, J9 and J10 are output lugs for load connections.

TP19, TP26, TP28 and TP31 are remote sense posts. These pins can be used to monitor and evaluate the system voltage regulations. If the user wants to use these test posts for remote sense, the R<sub>109</sub>, R<sub>120</sub>, R<sub>155</sub> and R<sub>161</sub> need to be changed to higher values, such as 10Ω. Also, the related voltage sense divider needs to be increased to a higher resistance, such as 1k.

Q<sub>26</sub>, Q<sub>27</sub>, R<sub>126</sub>, R<sub>156</sub>, R<sub>122</sub>, R<sub>131</sub>, R<sub>151</sub> and R<sub>153</sub> are circuit footprint options to add an on-board transient load to the regulator. Use a signal generator to apply a clock signal at TP22 (TP30) to generate step-up and step-down transient load. Make sure that the duty cycle of the clock is small enough to avoid burning load resistors R<sub>126</sub> and R<sub>156</sub>.

JP11 or JP12 are the jumpers used to disable the channels independently.

TP27 is a post that can be used to inject a clock signal for the controller to be synchronized with.

JP7 and JP8 are jumpers for r<sub>DS(ON)</sub> sensing configuring. Also, these jumpers can be used to monitor the DCR sensing capacitor voltage.

R<sub>94</sub>, C<sub>74</sub>, R<sub>163</sub> and C<sub>108</sub> are optional footprints for snubbers, which are used to filter the ringing at phase nodes.

R<sub>99</sub>, R<sub>100</sub>, R<sub>125</sub>, R<sub>130</sub>, R<sub>132</sub>, LED4 and Q<sub>32</sub> are useless footprints.

R<sub>121</sub> and C<sub>86</sub> are small added filters for the VIN pin. R<sub>145</sub> is used to isolate the noise at PVCC caused by driving. In 3.3V applications, R<sub>121</sub> and R<sub>145</sub> are recommended to short to 0 to prevent VCC from going below POR under low input voltage. Also, it is recommended to add a 2k resistor from LGATE to GND to discharge the low gate at the state of LGATE OFF.

## Quick Start

1. Ensure that the circuit is correctly connected to the supply and loads prior to applying any power.
2. Adjust the input supply to be 12V. Turn on the input power supply.

3. Verify that the two output voltages are correct. If the PGOOD is set high, the LED3 will be green. If the PGOOD is set low, the LED3 will be red. TP24 is the test post to monitor PGOOD.

## Evaluating the Other Output Voltage

The ISL8120EVAL3Z kit outputs are preset to 1.2V/25A, V<sub>OUT1</sub> can also be adjusted between 0.6V to 3V by changing the value of R<sub>119</sub> and R<sub>116</sub> for V<sub>OUT1</sub> as given by [Equation 1](#). The same rule applies for V<sub>OUT2</sub>.

$$R_{116} = \frac{R_{119}}{(V_{OUT1}/V_{REF}) - 1} \quad \text{Where } V_{REF} = 0.6V \quad (\text{EQ. 1})$$

## r<sub>DS(ON)</sub> Sense Configuration

If the desired output voltage is higher than 3V, the current sense has to be configured as r<sub>DS(ON)</sub> sensing because of the common-mode voltage limitation of the current sense differential amplifier. The default setup of ISL8120EVAL3Z is DCR sensing. The following steps show how to change to r<sub>DS(ON)</sub> sensing for Channel 2:

1. Remove R<sub>102</sub> and R<sub>96</sub> to be open.
2. Change R<sub>107</sub> and R<sub>95</sub> to be 0Ω.
3. Short jumper JP7.

## Programming the Input Voltage UVLO and its Hysteresis

By programming the voltage divider at the EN/FF pin connected to the input rail, the input UVLO and its hysteresis can be programmed. The ISL8120EVAL3Z has R<sub>129</sub> (R<sub>136</sub>) 13.7k and R<sub>135</sub> (R<sub>141</sub>) 4.42k; the IC will be disabled when input voltage drops below 3.38V and will restart until V<sub>IN</sub> recovers to be above 4.42V.

For 12V applications, it is suggested to have R<sub>129</sub> (R<sub>136</sub>) 33k and R<sub>135</sub> (R<sub>141</sub>) 5.1k, of which the IC is disabled when the input voltage drops below 6V and will restart until V<sub>IN</sub> recovers to be above 7V.

Refer to the [ISL8120](#) datasheet to program the UVLO falling threshold and hysteresis. The equations are restated in [Equations 2](#) and [3](#), where R<sub>UP</sub> and R<sub>DOWN</sub> are the upper and lower resistors of the voltage divider at EN/FF pin. V<sub>HYS</sub> is the desired UVLO hysteresis and V<sub>FTH</sub> is the desired UVLO falling threshold.

$$R_{UP} = \frac{V_{HYS}}{I_{HYS}} \quad \text{Where } I_{HYS} = 30\mu A \quad (\text{EQ. 2})$$

$$R_{DOWN} = \frac{R_{UP} \cdot V_{EN\_REF}}{V_{FTH} - V_{EN\_REF}} \quad \text{Where } V_{EN\_REF} = 0.8V \quad (\text{EQ. 3})$$

Note that the ISL8120 EN/FF pin is a triple function pin and the voltages applied to the EN/FF pins are also fed to adjust the amplitude of each channel's individual sawtooth.

## DDR Application

The ISL8120 can be used as a DDR controller. The Typical Application II schematic in the [ISL8120](#) datasheet shows its configuration. Channel 1 is used for VDDQ. VDDQ output is fed to the REFIN pin of Channel 2, thus Channel 2 can track VDDQ at start-up and supplies as VTT.

Please note the configuration of EN/FF pins for start-up timing. The VDDQ channel (Channel 1) start-up should be delayed to VTT (Channel 2) by adding more filtering at EN/FF1 than EN/FF2. This is to start up the internal SS ramp of Channel 2 and make it invalid because EN/FF2 is still 0 coming from VDDQ (Channel 1).

[Figure 2](#) shows the reference configurations and parameters of the EN/FF pins. RA is a resistor externally added as a filter resistor for EN/FF1.

With the configuration of [Figure 2](#), VDDQ is 1.8V and VTT is 0.9V. The gain of the resistor divider from VDDQ (Channel 1) to REFIN pin should have the same value with the resistor divider of VTT (Channel 2). RB is an externally added resistor for the upper resistor of the divider from VDDQ output to REFIN.

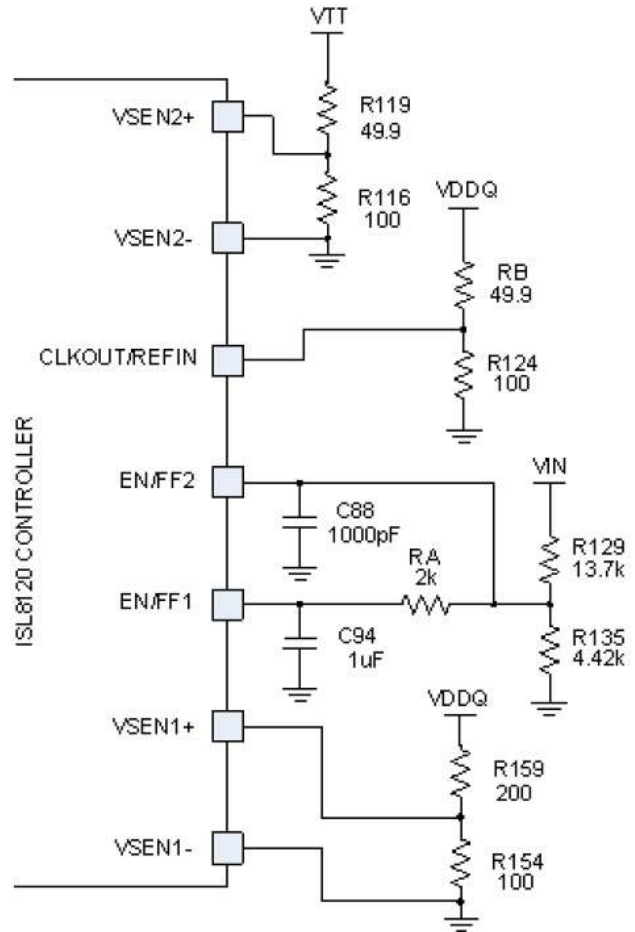

FIGURE 2. DDR CONFIGURATION



## ISL8120EVAL3Z Bill of Materials

REFERENCE DESCRIPTION	PART NUMBER	QTY	MANUFACTURER	DESCRIPTION
C123-C126	DNP	0		
C96, C97	GRM188R71H102KA	2	MURATA	CAP, SMD, 0603, 1000pF, 50V, 10%, X7R, ROHS
C88, C94	06032R103K8B20	2	PHILLIPS	CAP, SMD, 0603, 0.01μF, 25V, 10%, X7R, ROHS
C76, C106, C107, C116	GRM39X7R104K025AD	4	MURATA	CAP, SMD, 0603, 0.1μF, 25V, 10%, X7R, ROHS
C81, C101	ECJ-1VB1H153K	2	PANASONIC	CAP, SMD, 0603, 0.015μF, 50V, 10%, X7R, ROHS
C87, C100	C1608X7R1E224K	2	TDK	CAP, SMD, 0603, 0.22μF, 25V, 10%, X7R, ROHS
C82, C98	GMC10CG681J50NT	2	CAL-CHIP	CAP, SMD, 0603, 680pF, 50V, 5%, NPO, ROHS
C85, C99	ECJ-1VB1H822K	2	PANASONIC	CAP, SMD, 0603, 8200pF, 50V, 10%, X7R, ROHS
C74, C103, C108	DNP	0		CAP, SMD, 0603, DNP-PLACE HOLDER, ROHS
C95	C0805X5R160-106KNE	1	VENKEL	CAP, SMD, 0805, 10μF, 16V, 10%, X5R, ROHS
C86	GRM21BF51E155ZA01L	1	MURATA	CAP, SMD, 0805, 1.5μF, 25V,+80-20,Y5V, ROHS
C104	ECJ-2FB1E225K	1	PANASONIC	CAP, SMD, 0805, 2.2μF, 25V, 10%, X5R, ROHS
C112, C115	C1206X5R250-106KNE	2	VENKEL	CAP, SMD, 1206, 10μF, 25V, 10%, X5R, ROHS
C75, C109	C1206C475K3PACTU	2	KEMET	CAP, SMD, 1206, 4.7μF, 25V, 10%, X5R, ROHS
C79, C80, C113, C114	DNP	0		CAP, SMD, 1206, DNP-PLACE HOLDER, ROHS
C90, C91, C92, C93	ECJ-4YB1E106M	4	PANASONIC	CAP, SMD, 1210, 10μF, 25V, 20%, X5R, ROHS
C102, C128	25ZL1500M12.5X25	2	RUBYCON	CAP, RADIAL, 12.5X25, 1500μF, 25V, 20%, ALUM.ELEC., ROHS
C77, C78, C110, C111	2R5TPF470M7L	4	SANYO	CAP, POSCAP, SMD, 7.3X4.3, 470μF, 2.5V, 20%, 7mΩ, ROHS
L6, L7	PA1513.321NLT	2	PULSE	COIL-PWR INDUCTOR, SMD, 13mm, 320nH, 20%, 45A, Pb-free
J2	111-0702-001	1	JOHNSON COMPONENTS	CONN-GEN, BIND.POST, INSUL-RED, THMBNUT-GND
J1	111-0703-001	1	JOHNSON COMPONENTS	CONN-GEN,BIND.POST, INSUL-BLK, THMBNUT-GND
TP20, TP32	131-4353-00	2	TEKTRONIX	CONN-SCOPE PROBE TEST PT, COMPACT, PCB MNT, ROHS
TP1, TP3, TP19, TP21, TP22, TP24, TP25, TP26, TP27, TP28, TP30, TP31	5002	12	KEYSTONE	CONN-MINI TEST POINT, VERTICAL, WHITE, ROHS
JP7, JP8, JP11, JP12	69190-202	4	BERG/FCI	CONN-HEADER, 1x2, RETENTIVE, 2.54mm, ST, ROHS
LED4	DNP	0		
LED3	SSL-LXA3025IGC-TR	1	LUMEX	LED, SMD, 3mmx2.5mm, 4P, RED/GREEN, 12/20MCD, 2V
U3	ISL8120IRZ	1	INTERSIL	IC-DUAL PHASE PWM CONTROLLER, 32P, QFN, 5x5, ROHS
Q25	2N7002-7-F	1	DIODES, INC.	TRANSISTOR, N-CHANNEL, 3LD, SOT-23, 60V, 115mA, ROHS
Q1, Q2	DNP	0		DNP-PLACE HOLDER, TRANSIST-DUAL MOS, N-CHAN, 8P, SOIC, 30V, 6A, ROHS
Q26, Q27	DNP	0		DNP-PLACE HOLDER, TRANSIST-MOSFET, N-CHAN, 5P, LFFPAK, 30V, 9.4mΩ, ROHS
Q32	DNP	0		DNP-PLACE HOLDER

**ISL8120EVAL3Z Bill of Materials (Continued)**

REFERENCE DESCRIPTION	PART NUMBER	QTY	MANUFACTURER	DESCRIPTION
Q23, Q24, Q28, Q29	RJK0301DPB	4	RENESAS TECHNOLOGY	TRANSISTOR, N-CHANNEL, 5P, LFPAK, 30V, 60A, ROHS
Q21, Q22, Q30, Q31	RJK0305DPB	4	RENESAS TECHNOLOGY	TRANSISTOR, N-CHANNEL, 5P, LFPAK, 30V, 30A, ROHS
R145	CRCW06035R10FNEA	1	VISHAY/DALE	RES, SMD, 0603, 5.1Ω, 1/10W, 1%, TF, ROHS
R96, R102, R109, R120, R152, R155, R160, R161		8	Various	RESISTOR, SMD, 0603, 0Ω, 1/10W, TF, ROHS
R116, R119, R154, R159	RK73H1JT1000F	4	KOA	RES, SMD, 0603, 100Ω, 1/10W, 1%, TF, ROHS
R97, R98, R115, R147	RK73H1JT1001F	4	KOA	RES, SMD, 0603, 1k, 1/10W, 1%, TF, ROHS
R123, R140, R143	RK73H1JT1002F	3	KOA	RES, SMD, 0603, 10k, 1/10W, 1%, TF, ROHS
R129, R136	RC0603FR-0713K7L	2	YAGEO	RESISTOR, SMD, 0603, 13.7k, 1/10W, 1%, TF, ROHS
R103, R157	CR0603-10W-2490FT	2	VENKEL	RES, SMD, 0603, 249Ω, 1/10W, 1%, TF, ROHS
R111, R142	ERJ-3EKF4021V	2	PANASONIC	RES, SMD, 0603, 4.02kΩ, 1/10W, 1%, TF, ROHS
R135, R141	RC0603FR-074K42L	2	YAGEO	RES, SMD, 0603, 4.42k, 1/10W, 1%, TF, ROHS
R118, R146	CR0603-10W-45R3FT	2	VENKEL	RES, SMD, 0603, 45.3Ω, 1/10W, 1%, TF, ROHS
R95, R158	ERJ-3EKF6491V	2	PANASONIC	RES, SMD, 0603, 6.49k, 1/10W, 1%, TF, ROHS
R133	CR0603-10W-7682FT	1	VENKEL	RES, SMD, 0603, 76.8k, 1/10W, 1%, TF, ROHS
R99, R100, R107, R122, R124, R125, R128, R130 to R132, R149, R151, R153	DNP	0		RES, SMD, 0603, DNP-PLACE HOLDER, ROHS
R94, R163	DNP	0		RES, SMD, 0805, DNP-PLACE HOLDER, ROHS
R121	CR1206-4W-02R0	1	VENKEL	RES, SMD, 1206, 2Ω, 1/4W, 1%, TF, ROHS
R126, R156	DNP	0		RES, SMD, 2512, PLACE HOLDER, TF, ROHS
J7, J8, J9, J10	KPA8CTP	4	BERG/FCI	HDWARE, MTG, CABLE TERMINAL, 6-14AWG, LUG&SCREW, ROHS
TP23, TP29	DNP	0		DNP-PLACE HOLDER

# ISL8120EVAL3Z Board Layout

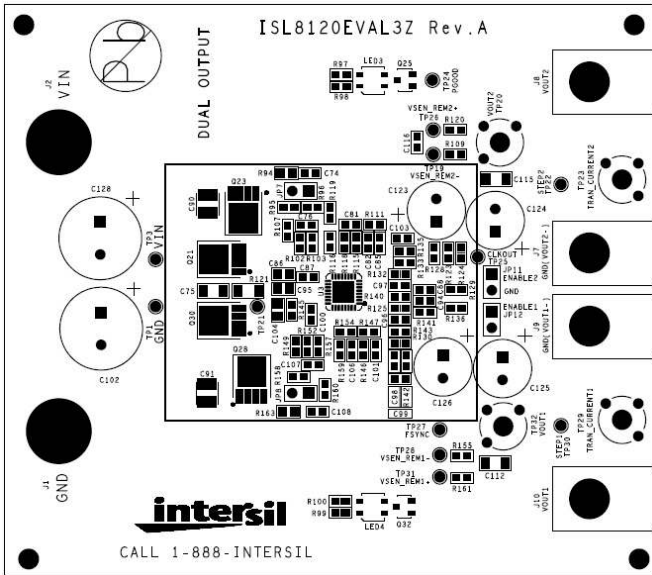

FIGURE 4. TOP SILKSCREEN

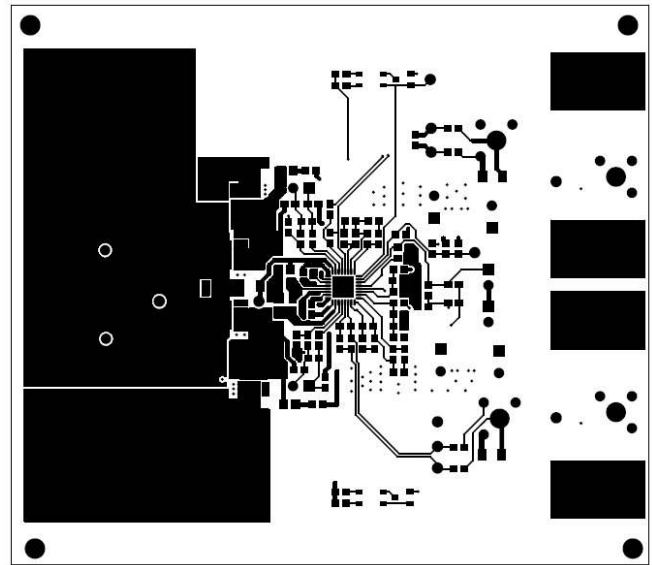

FIGURE 5. TOP LAYER

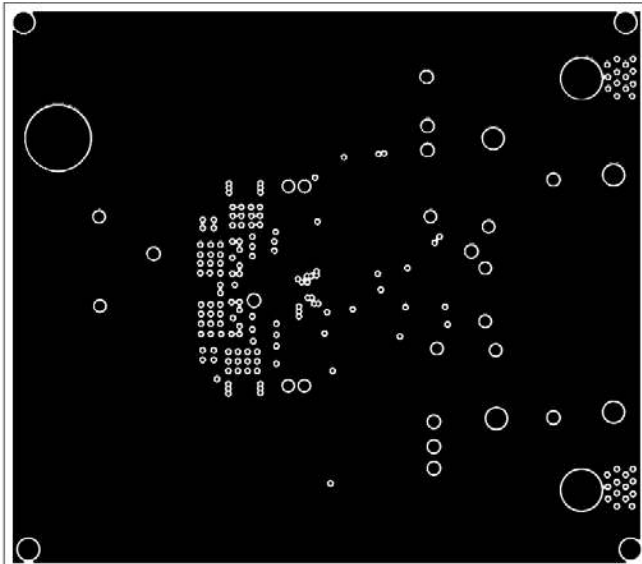

FIGURE 6. SECOND LAYER

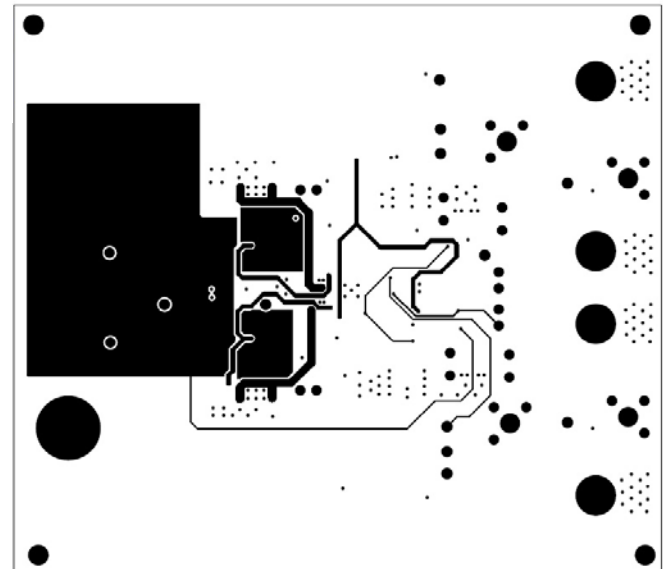

FIGURE 7. THIRD LAYER

# ISL8120EVAL3Z Board Layout (Continued)

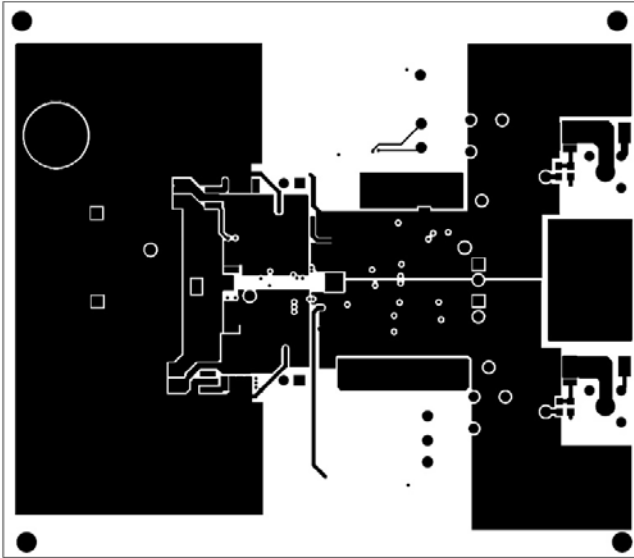

FIGURE 8. BOTTOM LAYER

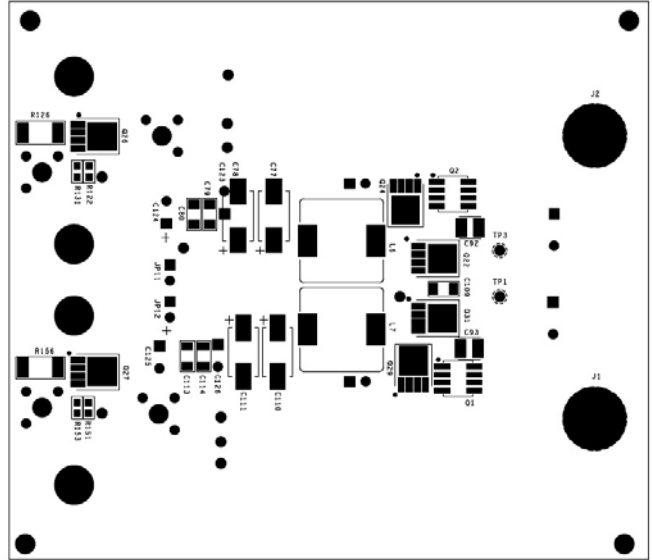

FIGURE 9. BOTTOM SILKSCREEN (MIRRORED)

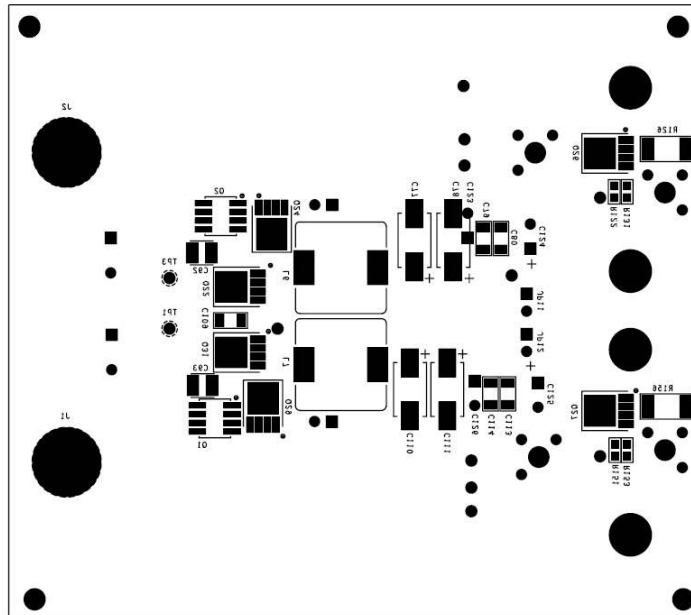

FIGURE 10. BOTTOM SILKSCREEN



# Test Data for ISL8120EVAL3Z

## Efficiency

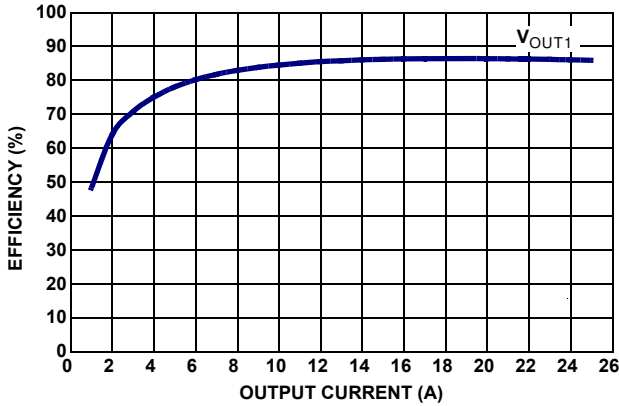

FIGURE 11. CHANNEL 1 EFFICIENCY (12V  $V_{IN}$  AND 1.2V  $V_{OUT}$ )

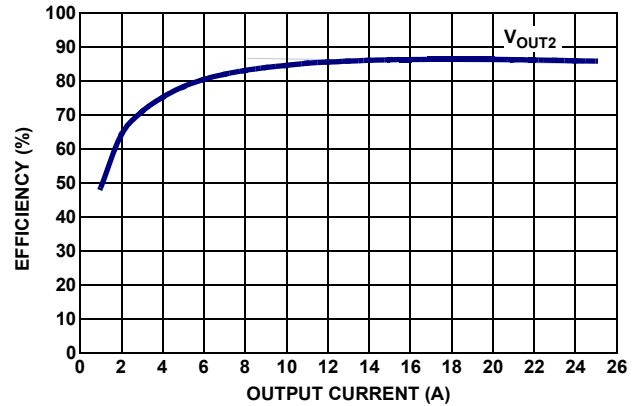

FIGURE 12. CHANNEL 2 EFFICIENCY (12V  $V_{IN}$  AND 1.2V  $V_{OUT}$ )

## Line Regulation

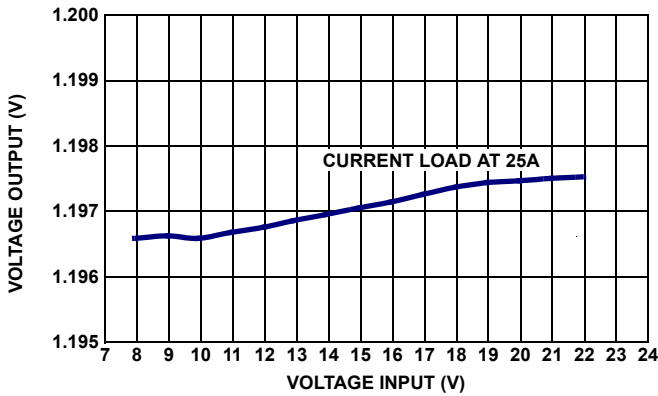

FIGURE 13. CHANNEL 1 LINE REGULATION

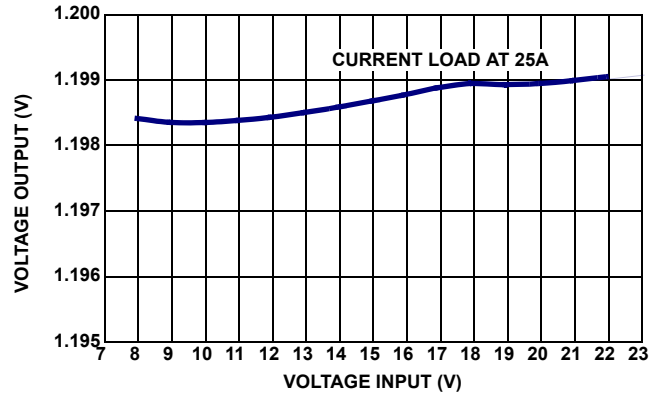

FIGURE 14. CHANNEL 1 LINE REGULATION

## Start-Up

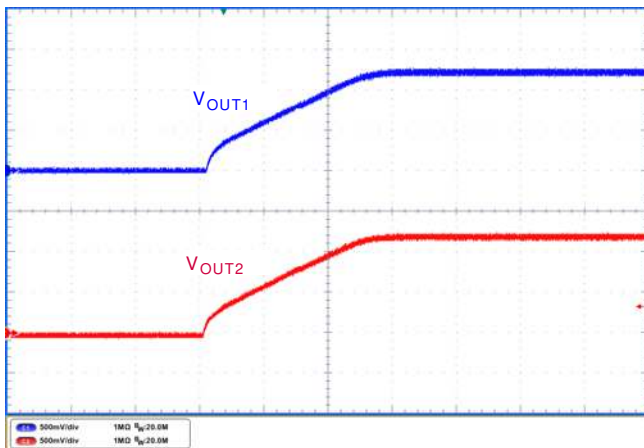

FIGURE 15. POWER-UP UNDER FULL LOAD (25A FOR EACH CHANNEL)

## Load Transient

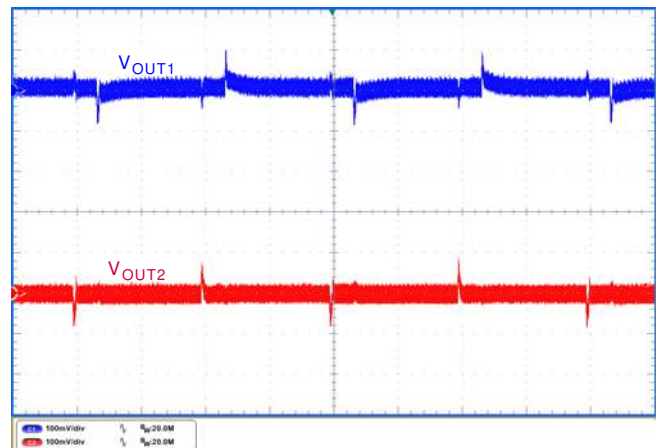

FIGURE 16. LOAD TRANSIENT (0A TO 25A STEP, SLEW\_RATE = 1.6A/MS)

# Test Data for ISL8120EVAL3Z (Continued)

## Output Ripple

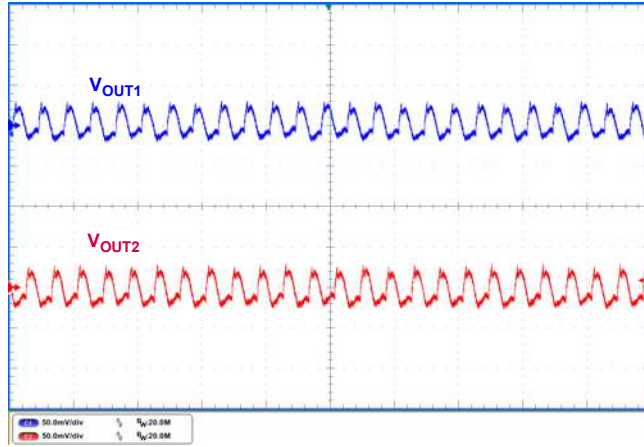

FIGURE 17. OUTPUT RIPPLES UNDER 25A LOAD FOR EACH CHANNEL

## DDR Application Waveforms

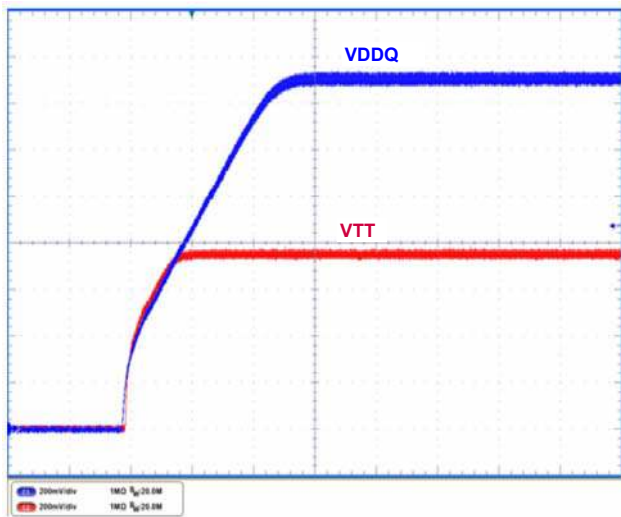

FIGURE 18. VDDQ AND VTT START-UP TRACKING (DDR3)

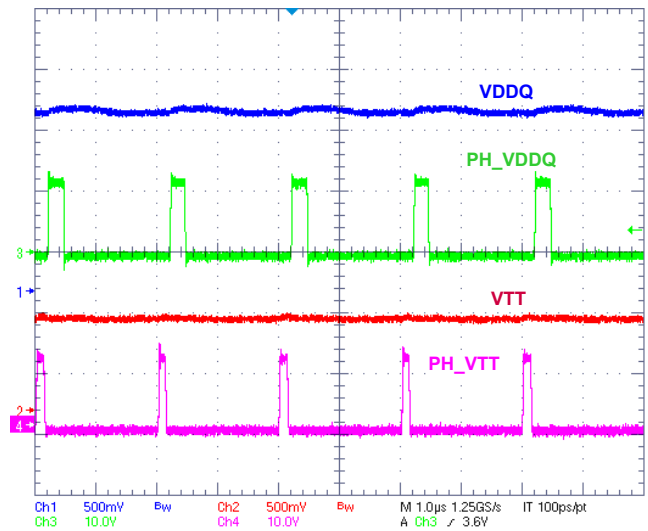

FIGURE 19. PHASE AND VOUTS (DDR3)

## Notice

1. Descriptions of circuits, software and other related information in this document are provided only to illustrate the operation of semiconductor products and application examples. You are fully responsible for the incorporation or any other use of the circuits, software, and information in the design of your product or system. Renesas Electronics disclaims any and all liability for any losses and damages incurred by you or third parties arising from the use of these circuits, software, or information.
2. Renesas Electronics hereby expressly disclaims any warranties against and liability for infringement or any other claims involving patents, copyrights, or other intellectual property rights of third parties, by or arising from the use of Renesas Electronics products or technical information described in this document, including but not limited to, the product data, drawings, charts, programs, algorithms, and application examples.
3. No license, express, implied or otherwise, is granted hereby under any patents, copyrights or other intellectual property rights of Renesas Electronics or others.
4. You shall not alter, modify, copy, or reverse engineer any Renesas Electronics product, whether in whole or in part. Renesas Electronics disclaims any and all liability for any losses or damages incurred by you or third parties arising from such alteration, modification, copying or reverse engineering.
5. Renesas Electronics products are classified according to the following two quality grades: "Standard" and "High Quality". The intended applications for each Renesas Electronics product depends on the product's quality grade, as indicated below.  
"Standard": Computers; office equipment; communications equipment; test and measurement equipment; audio and visual equipment; home electronic appliances; machine tools; personal electronic equipment; industrial robots; etc.  
"High Quality": Transportation equipment (automobiles, trains, ships, etc.); traffic control (traffic lights); large-scale communication equipment; key financial terminal systems; safety control equipment; etc.  
Unless expressly designated as a high reliability product or a product for harsh environments in a Renesas Electronics data sheet or other Renesas Electronics document, Renesas Electronics products are not intended or authorized for use in products or systems that may pose a direct threat to human life or bodily injury (artificial life support devices or systems; surgical implantations; etc.), or may cause serious property damage (space system; undersea repeaters; nuclear power control systems; aircraft control systems; key plant systems; military equipment; etc.). Renesas Electronics disclaims any and all liability for any damages or losses incurred by you or any third parties arising from the use of any Renesas Electronics product that is inconsistent with any Renesas Electronics data sheet, user's manual or other Renesas Electronics document.
6. When using Renesas Electronics products, refer to the latest product information (data sheets, user's manuals, application notes, "General Notes for Handling and Using Semiconductor Devices" in the reliability handbook, etc.), and ensure that usage conditions are within the ranges specified by Renesas Electronics with respect to maximum ratings, operating power supply voltage range, heat dissipation characteristics, installation, etc. Renesas Electronics disclaims any and all liability for any malfunctions, failure or accident arising out of the use of Renesas Electronics products outside of such specified ranges.
7. Although Renesas Electronics endeavors to improve the quality and reliability of Renesas Electronics products, semiconductor products have specific characteristics, such as the occurrence of failure at a certain rate and malfunctions under certain use conditions. Unless designated as a high reliability product or a product for harsh environments in a Renesas Electronics data sheet or other Renesas Electronics document, Renesas Electronics products are not subject to radiation resistance design. You are responsible for implementing safety measures to guard against the possibility of bodily injury, injury or damage caused by fire, and/or danger to the public in the event of a failure or malfunction of Renesas Electronics products, such as safety design for hardware and software, including but not limited to redundancy, fire control and malfunction prevention, appropriate treatment for aging degradation or any other appropriate measures. Because the evaluation of microcomputer software alone is very difficult and impractical, you are responsible for evaluating the safety of the final products or systems manufactured by you.
8. Please contact a Renesas Electronics sales office for details as to environmental matters such as the environmental compatibility of each Renesas Electronics product. You are responsible for carefully and sufficiently investigating applicable laws and regulations that regulate the inclusion or use of controlled substances, including without limitation, the EU RoHS Directive, and using Renesas Electronics products in compliance with all these applicable laws and regulations. Renesas Electronics disclaims any and all liability for damages or losses occurring as a result of your noncompliance with applicable laws and regulations.
9. Renesas Electronics products and technologies shall not be used for or incorporated into any products or systems whose manufacture, use, or sale is prohibited under any applicable domestic or foreign laws or regulations. You shall comply with any applicable export control laws and regulations promulgated and administered by the governments of any countries asserting jurisdiction over the parties or transactions.
10. It is the responsibility of the buyer or distributor of Renesas Electronics products, or any other party who distributes, disposes of, or otherwise sells or transfers the product to a third party, to notify such third party in advance of the contents and conditions set forth in this document.
11. This document shall not be reprinted, reproduced or duplicated in any form, in whole or in part, without prior written consent of Renesas Electronics.
12. Please contact a Renesas Electronics sales office if you have any questions regarding the information contained in this document or Renesas Electronics products.  
(Note 1) "Renesas Electronics" as used in this document means Renesas Electronics Corporation and also includes its directly or indirectly controlled subsidiaries.  
(Note 2) "Renesas Electronics product(s)" means any product developed or manufactured by or for Renesas Electronics.

(Rev.4.0-1 November 2017)



### SALES OFFICES

Renesas Electronics Corporation

<http://www.renesas.com>

Refer to "<http://www.renesas.com/>" for the latest and detailed information.

**Renesas Electronics America Inc.**  
1001 Murphy Ranch Road, Milpitas, CA 95035, U.S.A.  
Tel: +1-408-432-8888, Fax: +1-408-434-5351

**Renesas Electronics Canada Limited**  
9251 Yonge Street, Suite 8309 Richmond Hill, Ontario Canada L4C 9T3  
Tel: +1-905-237-2004

**Renesas Electronics Europe Limited**  
Dukes Meadow, Millboard Road, Bourne End, Buckinghamshire, SL8 5FH, U.K  
Tel: +44-1628-651-700, Fax: +44-1628-651-804

**Renesas Electronics Europe GmbH**  
Arcadiastrasse 10, 40472 Düsseldorf, Germany  
Tel: +49-211-6503-0, Fax: +49-211-6503-1327

**Renesas Electronics (China) Co., Ltd.**  
Room 1709 Quantum Plaza, No.27 ZhichunLu, Haidian District, Beijing, 100191 P. R. China  
Tel: +86-10-8235-1155, Fax: +86-10-8235-7679

**Renesas Electronics (Shanghai) Co., Ltd.**  
Unit 301, Tower A, Central Towers, 555 Langao Road, Putuo District, Shanghai, 200333 P. R. China  
Tel: +86-21-2226-0888, Fax: +86-21-2226-0999

**Renesas Electronics Hong Kong Limited**  
Unit 1601-1611, 16/F., Tower 2, Grand Century Place, 193 Prince Edward Road West, Mongkok, Kowloon, Hong Kong  
Tel: +852-2265-6688, Fax: +852-2886-9022

**Renesas Electronics Taiwan Co., Ltd.**  
13F, No. 363, Fu Shing North Road, Taipei 10543, Taiwan  
Tel: +886-2-8175-9600, Fax: +886-2-8175-9670

**Renesas Electronics Singapore Pte. Ltd.**  
80 Bendemeer Road, Unit #06-02 Hyflux Innovation Centre, Singapore 339949  
Tel: +65-6213-0200, Fax: +65-6213-0300

**Renesas Electronics Malaysia Sdn.Bhd.**  
Unit 1207, Block B, Menara Amcorp, Amcorp Trade Centre, No. 18, Jln Persiaran Barat, 46050 Petaling Jaya, Selangor Darul Ehsan, Malaysia  
Tel: +60-3-7955-9390, Fax: +60-3-7955-9510

**Renesas Electronics India Pvt. Ltd.**  
No.777C, 100 Feet Road, HAL 2nd Stage, Indiranagar, Bangalore 560 038, India  
Tel: +91-80-67208700, Fax: +91-80-67208777

**Renesas Electronics Korea Co., Ltd.**  
17F, KAMCO Yangjae Tower, 262, Gangnam-daero, Gangnam-gu, Seoul, 06265 Korea  
Tel: +82-2-558-3737, Fax: +82-2-558-5338