

SN54BCT29862B, SN74BCT29862B 10-BIT BUS TRANSCEIVERS WITH 3-STATE OUTPUTS

SCBS014B – NOVEMBER 1988 – REVISED NOVEMBER 1993

- BiCMOS Design Substantially Reduces Standby Current
- Functionally Equivalent to 'ALS29862 and AMD Am29862A
- Power-Up High-Impedance State
- ESD Protection Exceeds 2000 V Per Mil-STD-883C, Method 3015
- Package Options Include Plastic Small-Outline (DW) Packages, Ceramic Chip Carriers (FK) and Flatpacks (W), and Standard Plastic and Ceramic 300-mil DIPs (JT, NT)

description

These 10-bit bus transceivers are designed for asynchronous communication between data buses. The control-function implementation allows for maximum flexibility in timing.

These devices allow data transmission from the A bus to the B bus or from the B bus to the A bus, depending upon the logic levels at the output-enable (\overline{OEBA} and \overline{OEAB}) inputs.

The outputs are in the high-impedance state during power-up and power-down conditions. The outputs remain in the high-impedance state while the device is powered-down.

The SN54BCT29862B is characterized for operation over the full military temperature range of -55°C to 125°C . The SN74BCT29862B is characterized for operation from 0°C to 70°C .

SN54BCT29862B . . . JT OR W PACKAGE
SN74BCT29862B . . . DW OR NT PACKAGE
(TOP VIEW)

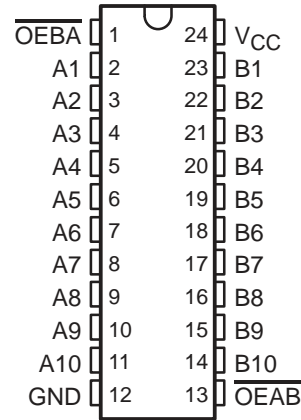

SN54BCT29862B . . . FK PACKAGE
(TOP VIEW)

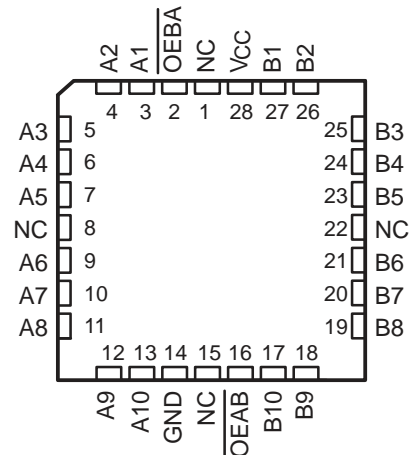

NC - No internal connection

FUNCTION TABLE

INPUTS		OPERATION
OEAB	OEBA	
L	H	\overline{A} to B
H	L	\overline{B} to A
H	H	Isolation
L	L	Latch A and B ($A = \overline{B}$)

SN54BCT29862B, SN74BCT29862B 10-BIT BUS TRANSCEIVERS WITH 3-STATE OUTPUTS

SCBS014B – NOVEMBER 1988 – REVISED NOVEMBER 1993

logic symbol†

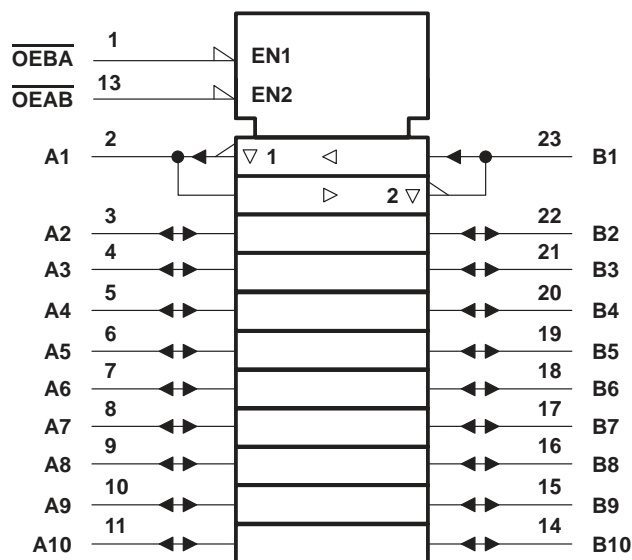

logic diagram (positive logic)

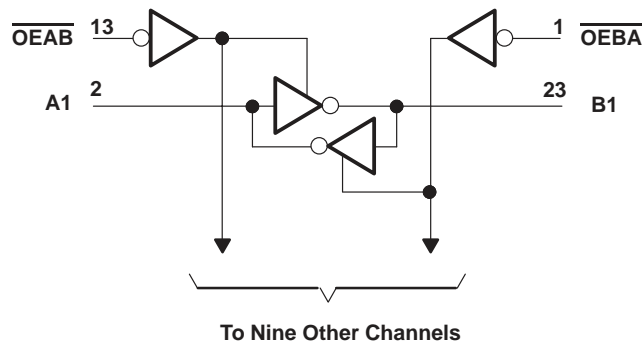

† This symbol is in accordance with ANSI/IEEE Std 91-1984 and IEC Publication 617-12.

Pin numbers shown are for the DW, JT, NT, and W packages.

absolute maximum ratings over operating free-air temperature range (unless otherwise noted)‡

Supply voltage, V_{CC}	–0.5 V to 7 V
Input voltage (I/O ports) (see Note 1)	–0.5 V to 5.5 V
Input voltage (excluding I/O ports) (see Note 1)	–0.5 V to 7 V
Voltage applied to any output in the high state	–0.5 V to V_{CC}
Input clamp current	–30 mA
Current into any output in the low state: SN54BCT29862B	48 mA
SN74BCT29862B	96 mA
Operating free-air temperature range: SN54BCT29862B	–55°C to 125°C
SN74BCT29862B	0°C to 70°C
Storage temperature range	–65°C to 150°C

‡ Stresses beyond those listed under “absolute maximum ratings” may cause permanent damage to the device. These are stress ratings only and functional operation of the device at these or any other conditions beyond those indicated under “recommended operating conditions” is not implied. Exposure to absolute-maximum-rated conditions for extended periods may affect device reliability.

NOTE 1: The input negative voltage rating may be exceeded if the input clamp current rating is observed.

recommended operating conditions

	SN54BCT29862B			SN74BCT29862B			UNIT
	MIN	NOM	MAX	MIN	NOM	MAX	
V_{CC} Supply voltage	4.5	5	5.5	4.5	5	5.5	V
V_{IH} High-level input voltage	2			2			V
V_{IL} Low-level input voltage			0.8			0.8	V
I_{IK} Input clamp current			–18			–18	mA
I_{OH} High-level output current			–12			–24	mA
I_{OL} Low-level output current			24			48	mA
T_A Operating free-air temperature	–55		125	0		70	°C

SN54BCT29862B, SN74BCT29862B 10-BIT BUS TRANSCEIVERS WITH 3-STATE OUTPUTS

SCBS014B – NOVEMBER 1988 – REVISED NOVEMBER 1993

electrical characteristics over recommended operating free-air temperature range (unless otherwise noted)

PARAMETER	TEST CONDITIONS		SN54BCT29862B			SN74BCT29862B			UNIT
			MIN	TYP†	MAX	MIN	TYP†	MAX	
V _{IK}	V _{CC} = 4.5 V, I _I = -18 mA		-1.2			-1.2			V
V _{OH}	V _{CC} = 4.5 V	I _{OH} = -12 mA	2.4	3.3		2.4	3.3		V
		I _{OH} = -24 mA				2	3.1		
V _{OL}	V _{CC} = 4.5 V	I _{OL} = 24 mA	0.35	0.5					V
		I _{OL} = 48 mA				0.35	0.5		
I _I	V _{CC} = 5.5 V, V _I = 5.5 V		0.1			0.1			mA
I _{IH}	Control inputs	V _{CC} = 5.5 V, V _I = 2.7 V	20			20			μA
	A or B port‡		70			70			
I _{IL}	Control inputs	V _{CC} = 5.5 V, V _I = 0.5 V	-0.2			-0.2			mA
	A or B port‡		-0.2			-0.2			
I _{IO(off)} §	V _{CC} = 0, V _O = 2.7 V		0.1			0.1			mA
I _{OS} ¶	V _{CC} = 5.5 V, V _O = 0		-75		-250	-75		-250	mA
I _{CC}	V _{CC} = 5.5 V	Outputs high	20	32		20	32		mA
		Outputs low	29	46		29	46		
		Outputs disabled	6.5	11		6.5	11		
C _i	V _{CC} = 5 V, V _I = 0.5 V or 2.5 V		6			6			pF
C _o	V _{CC} = 5 V, V _I = 0.5 V or 2.5 V		8			8			pF

† All typical values are at V_{CC} = 5 V, T_A = 25°C.

‡ For I/O ports, the parameters I_{IH} and I_{IL} include the off-state output current.

§ I_{O(off)} = Power-off bus leakage current

¶ Not more than one output should be shorted at a time and duration of the short circuit should not exceed one second.

switching characteristics (see Note 2)

PARAMETER	FROM (INPUT)	TO (OUTPUT)	V _{CC} = 5 V, C _L = 50 pF, R ₁ = 500 Ω, R ₂ = 500 Ω, T _A = 25°C			V _{CC} = 4.5 V to 5.5 V, C _L = 50 pF, R ₁ = 500 Ω, R ₂ = 500 Ω, T _A = MIN to MAX#				UNIT
			'BCT29862B			SN54BCT29862B		SN74BCT29862B		
			MIN	TYP	MAX	MIN	MAX	MIN	MAX	
t _{PLH}	A or B	B or A	1	3.6	5.2	1	6.5	1	6.1	ns
t _{PHL}			0.5	2.4	4.6	0.5	7.5	0.5	4.8	
t _{PZH}	$\overline{\text{OE}}$	A or B	2.5	5.3	7.2	2.5	9.1	2.5	8.4	ns
t _{PZL}			4.5	8	10.6	4.5	13.9	4.5	12.5	
t _{PHZ}	$\overline{\text{OE}}$	A or B	2.3	4.8	7.6	2.3	8.4	2.3	8.4	ns
t _{PLZ}			2.3	5.2	7	2.3	9.1	2.3	8.2	

For conditions shown as MIN or MAX, use the appropriate value specified under recommended operating conditions.

NOTE 2: Load circuits and voltage waveforms are shown in Section 1.



IMPORTANT NOTICE

Texas Instruments and its subsidiaries (TI) reserve the right to make changes to their products or to discontinue any product or service without notice, and advise customers to obtain the latest version of relevant information to verify, before placing orders, that information being relied on is current and complete. All products are sold subject to the terms and conditions of sale supplied at the time of order acknowledgement, including those pertaining to warranty, patent infringement, and limitation of liability.

TI warrants performance of its semiconductor products to the specifications applicable at the time of sale in accordance with TI's standard warranty. Testing and other quality control techniques are utilized to the extent TI deems necessary to support this warranty. Specific testing of all parameters of each device is not necessarily performed, except those mandated by government requirements.

CERTAIN APPLICATIONS USING SEMICONDUCTOR PRODUCTS MAY INVOLVE POTENTIAL RISKS OF DEATH, PERSONAL INJURY, OR SEVERE PROPERTY OR ENVIRONMENTAL DAMAGE ("CRITICAL APPLICATIONS"). TI SEMICONDUCTOR PRODUCTS ARE NOT DESIGNED, AUTHORIZED, OR WARRANTED TO BE SUITABLE FOR USE IN LIFE-SUPPORT DEVICES OR SYSTEMS OR OTHER CRITICAL APPLICATIONS. INCLUSION OF TI PRODUCTS IN SUCH APPLICATIONS IS UNDERSTOOD TO BE FULLY AT THE CUSTOMER'S RISK.

In order to minimize risks associated with the customer's applications, adequate design and operating safeguards must be provided by the customer to minimize inherent or procedural hazards.

TI assumes no liability for applications assistance or customer product design. TI does not warrant or represent that any license, either express or implied, is granted under any patent right, copyright, mask work right, or other intellectual property right of TI covering or relating to any combination, machine, or process in which such semiconductor products or services might be or are used. TI's publication of information regarding any third party's products or services does not constitute TI's approval, warranty or endorsement thereof.