

# RAS1 S Beam Load Cell

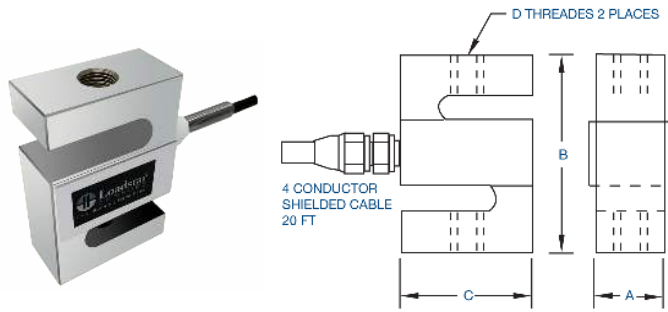

## Dimensions

Capacity	lb					
	25, 50, 100	250, 500, 1K	2.5k	5k, 10k	20k	40k
A	0.50	0.75	1.00	1.00	2.00	2.40
B	2.50	3.00	3.00	4.25	7.00	7.40
C	2.0	2.0	2.0	3.0	5.00	5.50
D	1/4-28	1/2-20	1/2-20	3/4-16	1 1/4 - 12	1 1/2 - 12

(All dimensions are in inches)

## Accuracy Specifications

Accuracy	
Non-linearity	± 0.02% of Full Scale
Hysteresis	± 0.02% of Full Scale
Non-repeatability	± 0.02% of Full Scale

## Calibration Options

SKU	Mode
*C01	Compression
*C02	Tension
*C03	Universal

## Wiring Information

Cable Color Code	
Red	+ Excitation
Black	- Excitation
Green	+ Signal
White	- Signal

## Load Cell Specifications

Zero Balance	± 2%
Safe Overload	to 150% of capacity (300% Ultimate Overload)
Rated Excitation	5 - 10 VDC
Full Scale Output	3 mV/V ± 10%
Connections	20ft Cable
Input Impedance	385 ± 30 Ohm
Output Impedance	350 ± 4 Ohm
Insulation	> 5,000 MΩ
Creep, in 1 hour	± 0.05% of Full Scale
Operating Temperature Range	-20°C to 60°C with TARE
Compensated Temperature Range	-10°C to 40°C with TARE
Temperature Effect on Output	20 ppm/°C of Load
Temperature Effect on Zero	20 ppm/°C of Rated Output

## Ordering Information

Multiple Load Cell Capacities With Overload Protection	
RAS1	Part No.
25 pounds	RAS1-025S-S
50 pounds	RAS1-050S-S
100 pounds	RAS1-100S-S
250 pounds	RAS1-250S-S
500 pounds	RAS1-500S-S
1000 pounds	RAS1-01KS-S
2500 pounds	RAS1-2HKS-S
5000 pounds	RAS1-05KS-S
10000 pounds	RAS1-10KS-S
20000 pounds	RAS1-20KS-S
40000 pounds	RAS1-40KS-S

## Compatible Accessories

### Recommended Interfaces



USB Interface

**1 Channel:**  
 DI-100U (40 Hz)  
 DI-100UHS (250 Hz)  
 DI-1000U (60 Hz)  
 DI-1000UHS (500 Hz)  
 DI-10000UHS-1K (1 KHz)  
 DI-1000UHS-10K (50 KHz)

**4 Channel:**  
 DI-400U (40 Hz)  
 DI-400UHS (250 Hz)



Wireless Interface

DI-1000ZP  
 DI-1000WiFi  
 DI-1000BLE



Analog Interface

AI-1000 (0-5 VDC)  
 AI-1000CV (0-5 VDC, 4-20 mA)



Touchscreen Display

DS-3000Pro-1 (1 Channel)  
 DS-3000Pro-4 (4 Channel)

## Compatible Software

1 Channel	LoadVUE Pro	Load, Weight, Force
Multi Channel	SensorVUE	All Supported Sensors
Multi Channel	ControlVUE	All Supported Sensors and USB Relays

## RES2 Miniature S-Beam Load Cell



For lower capacities and small size, checkout RES2. These are available in 5 kg, 10 kg, and 50 kg capacities.

### USB Load Cell Configuration

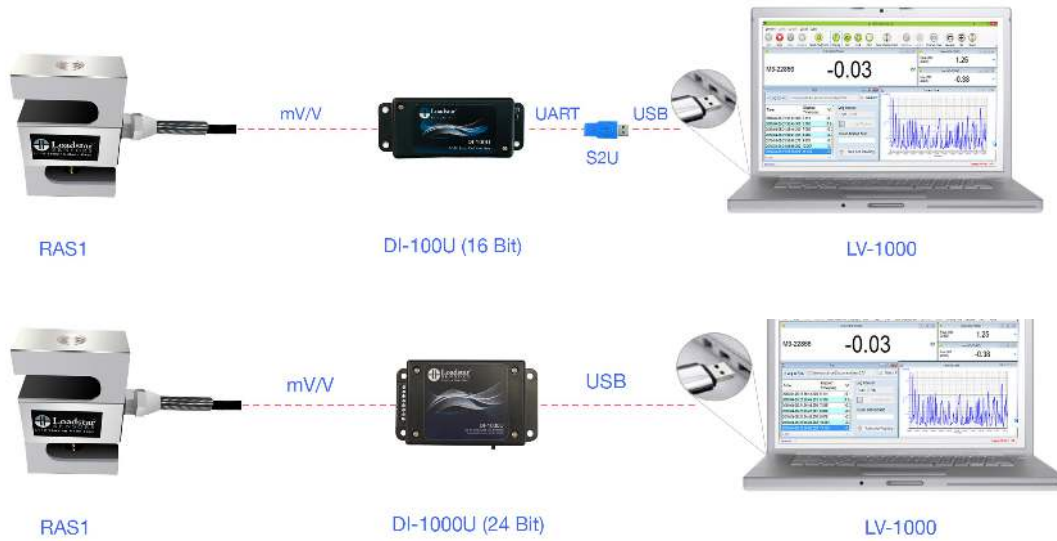

### Wireless Load Cell Configuration



### Analog Load Cell Configuration



### USB Load Cell with LCD Display

