

PRODUCT NUMBER
SEE TABLE

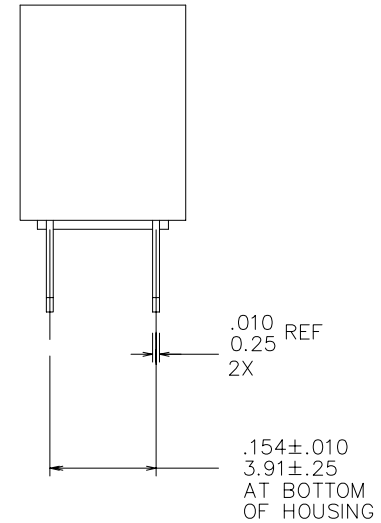
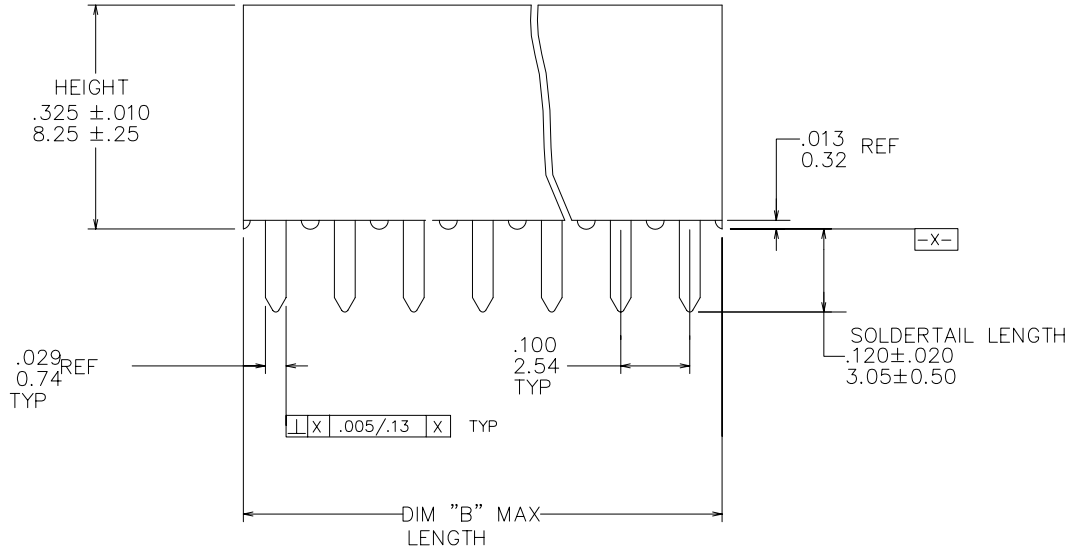
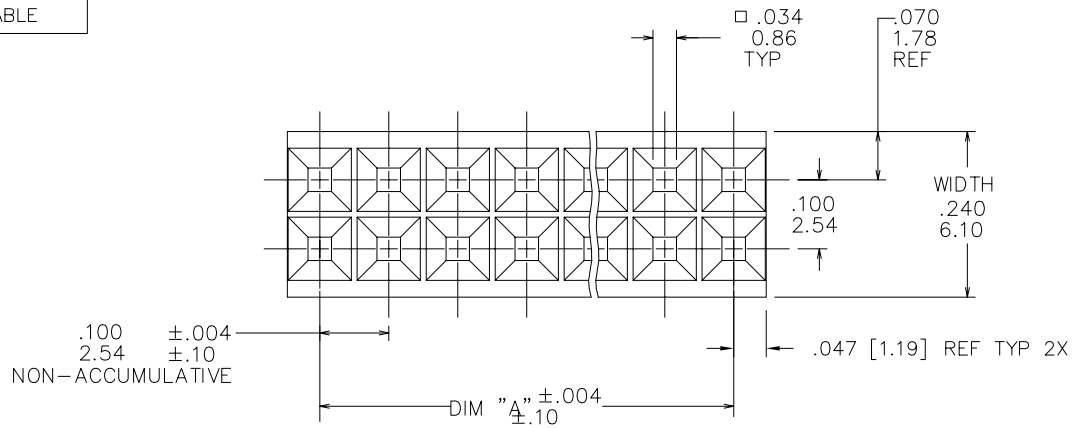

mat'l. code				surface ISO 1302 ✓		tolerance ISO 406 ISO 1101		projection ⊕		product family CARD CONN	
tr ecn no dr date				tolerances unless otherwise specified		.XX±.01/.X±.3		INCH/MM		title	
D V23244 MRC 9/30/92				angles		linear		.XXX±.0.005/.XXX±.13		VERT. CARD CONNECTOR	
E V70080 MDF 2/24/96				0'±2'		.XXXX±.0020/.XXX±.051		scale 4:1		.154/3.91 CTR., DBL ROW	
F M05-0216 ERE 10/11/05				dr		M. CORNMAN 9/30/92		FCI		dwg no sheet 1 of 3 size	
G M06-0210 MHT 6/03/06				enr		W. NORTHEY 9/30/92				65936 A3	
				chr		C.GINGRICH 9/30/92				type Product Customer Drawing	
				app		W. NORTHEY 9/30/92					
sheet index		revision sheet		G G		G G					
		1 2		3							

PRODUCT NUMBER

SEE TABLE

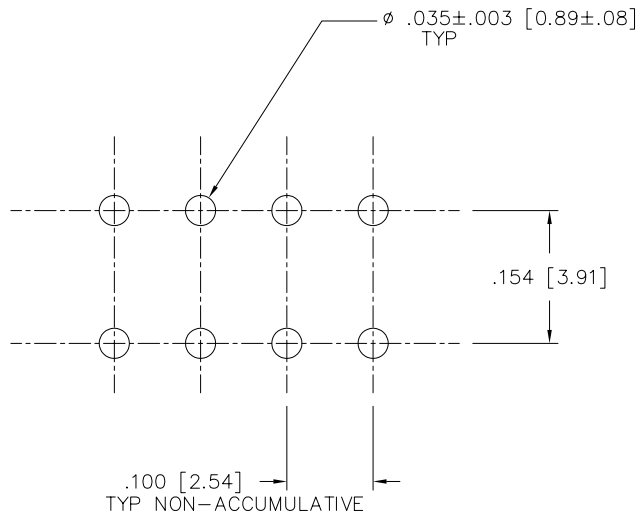

RECOMMENDED HOLE PATTERN
SCALE 5/1

NOTES:

- ① HOUSING MAT'L: FILLED POLYESTER,
FLAME RETARDANT PER UL 94V-0.
COLOR : BLACK.
- ② TERMINAL MATERIAL AND PLATING:
BODY: BRASS .010/0.25 THICK
SPRING: Be-Cu, HEAT TREATED
BODY PLATING: 15u"/.38u Au OVER 50u"/1.27u Ni
IN CONTACT AREA.
SPRING PLATING: Au FLASH
3. MARK FCI PART NUMBER AND DATE CODE LEGIBLE
ON TUBE LABEL
4. APPLICATION INFORMATION:
A. RECOMMENDED MOUNTING HOLE PATTERN
IS SHOWN IN DETAIL "A"
B. ALL MATING PINS TO BE .025/.64 SQ
ON TRUE CENTER OF GIVEN TERMINAL
SPACING WITHIN .015/.38.
C. SUGGESTED MATING PIN LENGTH
.350±.020/8.89±0.51.
- ⑤ ADD "LF" SUFFIX AT THE END OF PART NUMBER
FOR LEAD FREE OPTION.
6. THESE PRODUCTS MEET EUROPEAN UNION DIRECTIVES
AND OTHER COUNTRY REGULATIONS AS DESCRIBED IN
GS-22-008.
7. THIS PART WILL WITHSTAND EXPOSURE TO 260°C PEAK
TEMPERATURE FOR 20 SECONDS IN WAVE SOLDER,
INFRA-RED OR VAPOR PHASE SOLDER PROCESS.



FCIconnect.com

Copyright FCI

mat'l. code		surface ISO 1302 <input checked="" type="checkbox"/>		tolerance ISO 406 ISO 1101		projection 		product family CARD CONN	
ltr		ecn no dr		date		tolerances unless otherwise specified		title	
G						.XX±.01/.X±.3 linear		INCH/MM	
				0'±2'		.XXX±.0.005/.XX±.13 XXXX±.0020/XXX±.051		scale 4:1	
		dr		M. CORNMAN		9/30/92		dwg no	
		enfr		W. NORTHEY		9/30/92		sheet 2 of 3 size	
		chr		C.GINGRICH		9/30/92		65936 A3	
		appd		W. NORTHEY		9/30/92		type Product Customer Drawing	
sheet index		revision sheet							

PRODUCT NO	SIZE	DIM A	DIM B MAX	LEAD FREE OPTION
65936-001	UNASSIGNED			
-002	2 X 2	.100/2.54	.200/5.08	NOTE 5
-003	2 X 3	.200/5.08	.300/7.62	
-004	2 X 4	.300/7.62	.400/10.16	
-005	2 X 5	.400/10.16	.500/12.70	
-006	2 X 6	.500/12.70	.600/15.24	
-007	2 X 7	.600/15.24	.700/17.78	
-008	2 X 8	.700/17.78	.800/20.32	
-009	2 X 9	.800/20.32	.900/22.86	
-010	2 X 10	.900/22.86	1.000/25.40	
-011	2 X 11	1.000/25.40	1.100/27.94	
-012	2 X 12	1.100/27.94	1.200/30.48	
-013	2 X 13	1.200/30.48	1.300/33.02	
-014	2 X 14	1.300/33.02	1.400/35.56	
-015	2 X 15	1.400/35.56	1.500/38.10	
-016	2 X 16	1.500/38.10	1.600/40.64	
-017	2 X 17	1.600/40.64	1.700/43.18	
-018	2 X 18	1.700/43.18	1.800/45.72	
-019	2 X 19	1.800/45.72	1.900/48.26	
-020	2 X 20	1.900/48.26	2.000/50.08	
-021	2 X 21	2.000/50.08	2.100/53.34	
-022	2 X 22	2.100/53.34	2.200/55.88	
-023	2 X 23	2.200/55.88	2.300/58.42	
-024	2 X 24	2.300/58.42	2.400/60.96	
-025	2 X 25	2.400/60.96	2.500/63.50	
-026	2 X 26	2.500/63.50	2.600/66.04	
-027	2 X 27	2.600/66.04	2.700/68.58	
65936-028	2 X 28	2.700/68.58	2.800/71.12	

PRODUCT NO	SIZE	DIM A	DIM B MAX	LEAD FREE OPTION
65936-029	2 X 29	2.800/71.12	2.900/73.66	NOTE 5
-030	2 X 30	2.900/73.66	3.000/76.20	
-031	2 X 31	3.000/76.20	3.100/78.74	
-032	2 X 32	3.100/78.74	3.200/81.28	
-033	2 X 33	3.200/81.28	3.300/83.82	
-034	2 X 34	3.300/83.82	3.400/86.36	
-035	2 X 35	3.400/86.36	3.500/88.90	
65936-036	2 X 36	3.500/88.90	3.600/91.44	



FCIconnect.com

Copyright FCI

mat'l. code		surface ISO 1302		tolerance ISO 406 ISO 1101		projection 		product family CARD CONN	
ltr		ecn no		date		tolerances unless otherwise specified		title	
G						.XX±.01/.X±.3 linear .XXX±.0.005/.XX±.13 XXXX±.0020/XXX±.051		INCH/MM scale 4:1	
						dr M. CORNMAN 9/30/92		sheet 3 of 3 size	
						enrg W. NORTHEY 9/30/92		65936 A3	
						chr C.GINGRICH 9/30/92		type Product Customer Drawing	
						appd W. NORTHEY 9/30/92			
sheet index		revision sheet							

form: A3 1 2 3 4 5 6