

DESIGNED & DIMENSIONED  
IN MILLIMETERS [INCHES]

DO NOT  
SCALE FROM  
THIS PRINT

**SMA-J-C-XX-ST-B10**

- GENDER  
-J: JACK
- TYPE  
-C: CABLE
- TERMINATION  
-B10: BULKHEAD  
(RG58 CABLE)
- ORIENTATION  
-ST: STRAIGHT
- PLATING SPECIFICATION  
-H: 30μ" GOLD CENTER CONTACT  
3μ" MIN ON OUTER CONTACT  
-GF: 10μ" GOLD ON CENTER CONTACT  
3μ" GOLD ON OUTER CONTACT

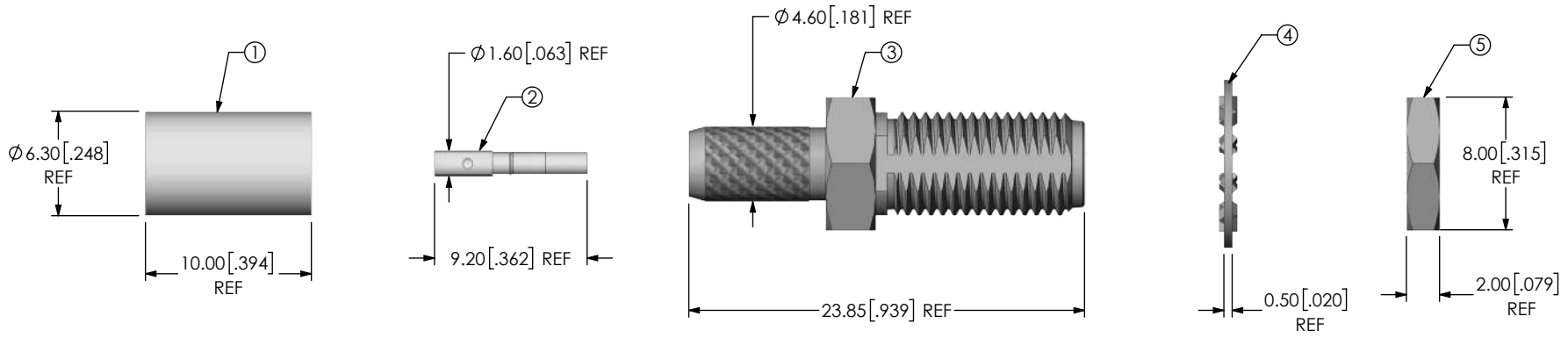

**TABLE 1**

ITEM	COMPONENT	-H	-GF
1	FERRULE	TNC-FER-003-F	
2	PIN	SMA-J-C-H-ST-B10-SKT	SMA-J-C-G-ST-B10-SKT
3	SUB ASSEMBLY	SUB-SMA-J-C-F-ST-B10	
4	LOCK WASHER	SMA-LWAS-001-F	
5	HEXNUT	SMA-NUT-001-F	

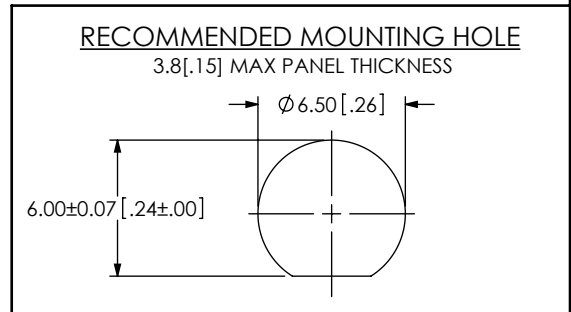

- NOTES:
1. NOTE DELETED.
  2. NOTE DELETED.
  3. PRODUCT TO BE PACKAGED PER PACKAGING STANDARD CO-RF-WI-3040M.
  4. NOTE DELETED.
  5. NOTE DELETED.
  6. NOTE DELETED.

<p>UNLESS OTHERWISE SPECIFIED, DIMENSIONS ARE IN MILLIMETERS [INCHES]. TOLERANCES ARE:</p> <p>DECIMALS      ANGLES</p> <p>.X: ±0.3 [0.01]      5°</p> <p>.XX: ±0.13 [0.005]</p> <p>.XXX: ±0.051 [0.0020]</p>	<p><b>PROPRIETARY NOTE</b></p> <p>THIS DOCUMENT CONTAINS CONFIDENTIAL AND PROPRIETARY INFORMATION AND ALL DESIGN, MANUFACTURING, REPRODUCTION, USE, PATENT RIGHTS AND SALES RIGHTS ARE EXPRESSLY RESERVED BY SAMTEC, INC. THIS DOCUMENT SHALL NOT BE DISCLOSED, IN WHOLE OR PART, TO ANY UNAUTHORIZED PERSON OR ENTITY NOR REPRODUCED, TRANSFERRED OR INCORPORATED IN ANY OTHER PRODUCT IN ANY MANNER WITHOUT THE EXPRESS WRITTEN CONSENT OF SAMTEC, INC.</p>		
		<p>520 PARK EAST BLVD, NEW ALBANY, IN 47150 PHONE: 812-944-6733    FAX: 812-948-5047 e-Mail: info@SAMTEC.com    code: 55322</p>	
<p><b>MATERIAL:</b> DO NOT SCALE DRAWING      SHEET SCALE: 3:1</p> <p>BODY, FERRULE, NUT, WASHER: BRASS CONTACT: BeCu DIELECTRIC: PTFE</p>		<p>DESCRIPTION: 50 OHM, SMA STRAIGHT JACK BULKHEAD, RG58</p> <p>DWG. NO. <b>SMA-J-C-XX-ST-B10</b></p>	
<p>BY: ALVIN W    09/07/2010</p>		<p>SHEET 1 OF 2</p>	

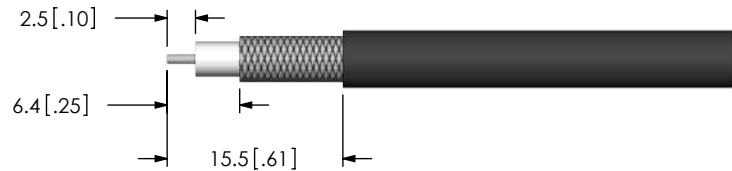

**IN PROCESS 1**  
STRIP CABLE AND TIN INNER CONDUCTOR

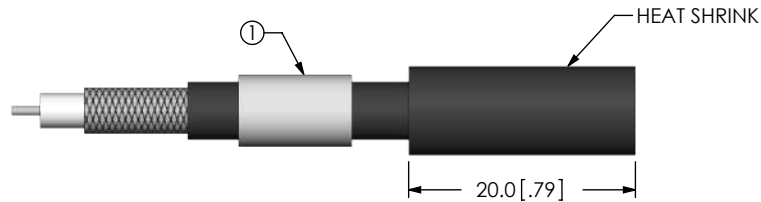

**IN PROCESS 2**  
ADD HEAT SHRINK TUBING AND FERRULE



**IN PROCESS 3**  
SOLDER SIGNAL PIN



**IN PROCESS 4**  
FLARE SHIELD AND ADD SUB ASSEMBLY

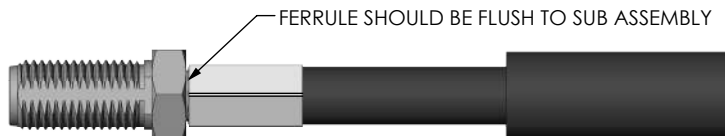

**IN PROCESS 5**  
CRIMP FERRULE  
(USE RF CRIMP HAND TOOL #CAT-RF-FER-001 AND .213" DIE SIZE)

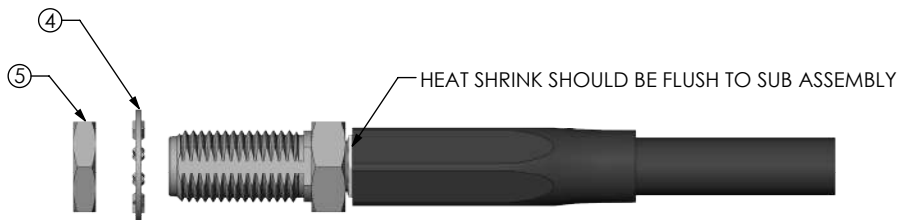

**IN PROCESS 6**  
ACTIVATE HEAT SHRINK TUBING

**PROPRIETARY NOTE**  
THIS DOCUMENT CONTAINS CONFIDENTIAL AND PROPRIETARY INFORMATION AND ALL DESIGN, MANUFACTURING, REPRODUCTION, USE, PATENT RIGHTS AND SALES RIGHTS ARE EXPRESSLY RESERVED BY SAMTEC, INC. THIS DOCUMENT SHALL NOT BE DISCLOSED, IN WHOLE OR PART, TO ANY UNAUTHORIZED PERSON OR ENTITY NOR REPRODUCED, TRANSFERRED OR INCORPORATED IN ANY OTHER PROJECT IN ANY MANNER WITHOUT THE EXPRESS WRITTEN CONSENT OF SAMTEC, INC.

DO NOT SCALE DRAWING

SHEET SCALE: 3:2



520 PARK EAST BLVD, NEW ALBANY, IN 47150  
PHONE: 812-944-6733 FAX: 812-948-5047  
e-Mail: info@SAMTEC.com code: 55322

DESCRIPTION:  
50 OHM, SMA STRAIGHT JACK BULKHEAD, RG58

DWG. NO. SMA-J-C-XX-ST-B10

BY: ALVIN W 09/07/2010 SHEET 2 OF 2