

NUMBER  
C-1470223

3RD ANGLE PROJECTION

METRIC

THIS INFORMATION IS CONFIDENTIAL AND IS DISCLOSED TO YOU ON CONDITION THAT NO FURTHER DISCLOSURE IS MADE BY YOU TO OTHER THAN AMP PERSONNEL WITHOUT WRITTEN AUTHORIZATION FROM AMP (TAIWAN) LTD. DIMENSIONS IN MILLIMETERS. DO NOT SCALE PRINT.

PRINT  
DW

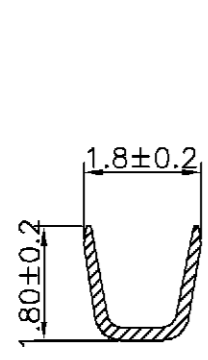
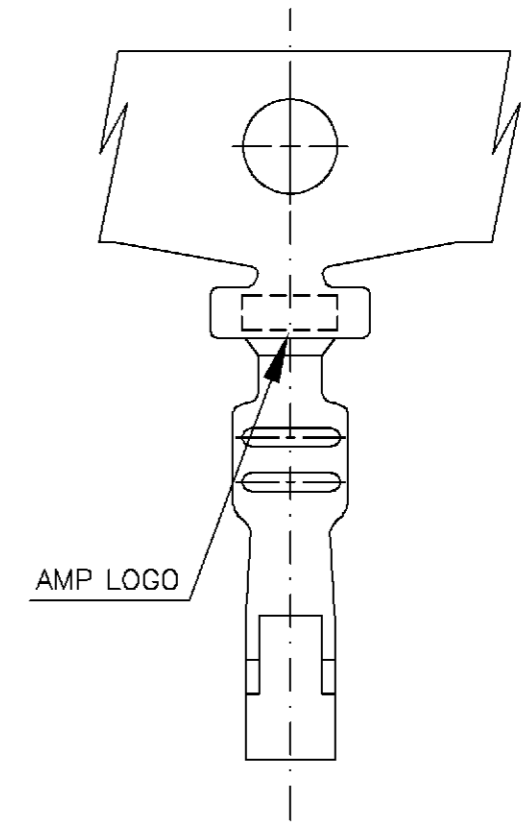
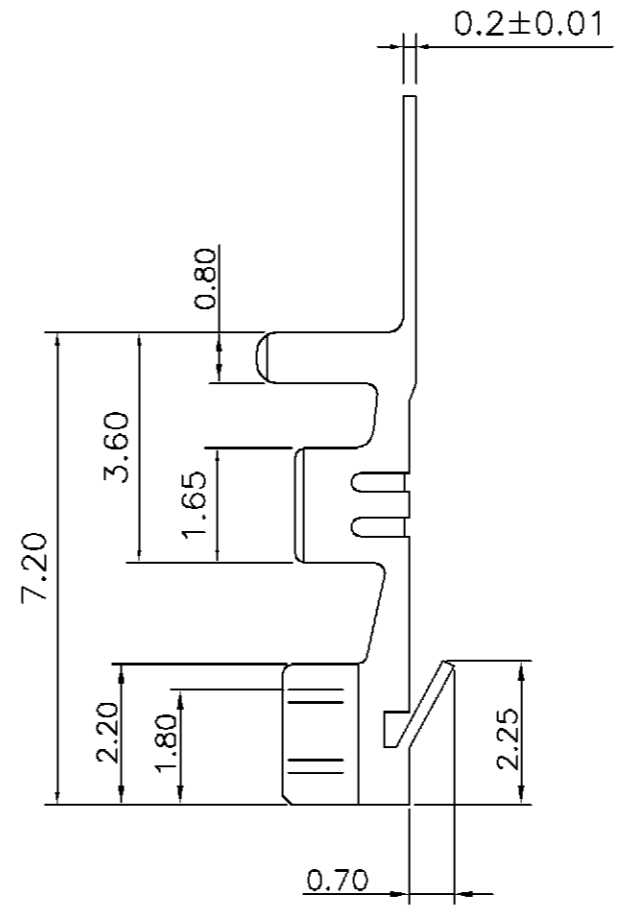
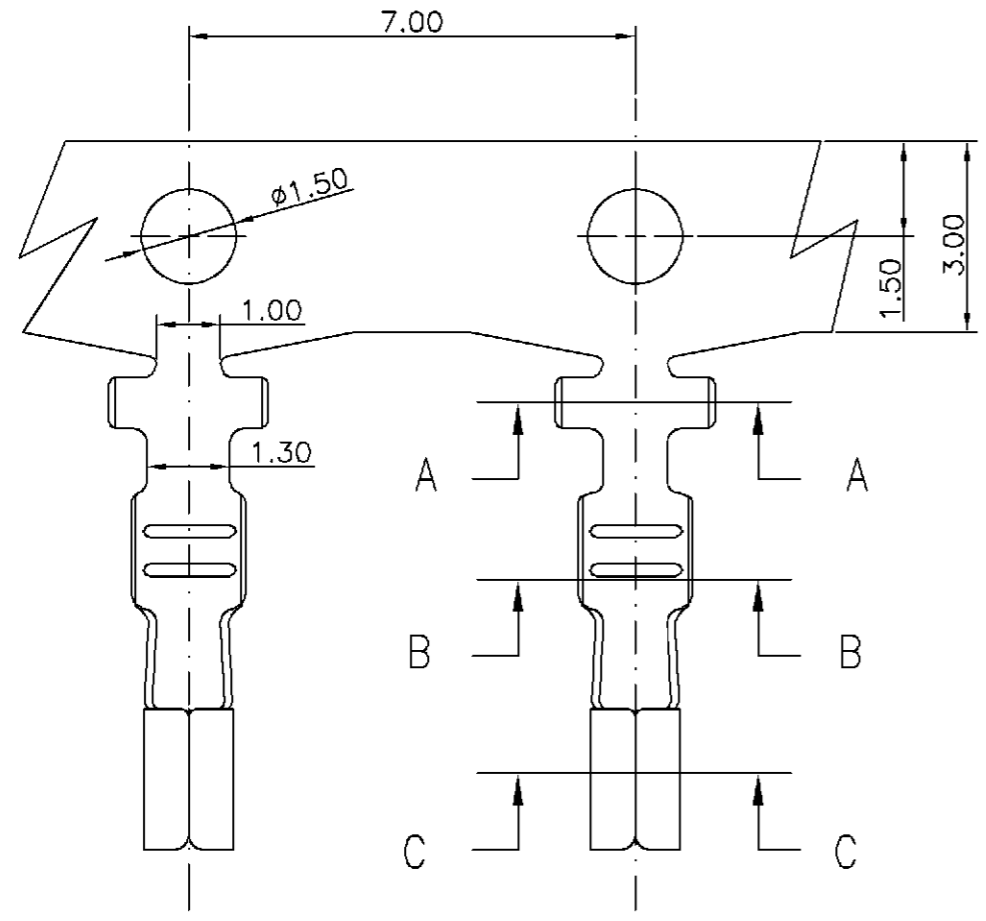

SEC B-B

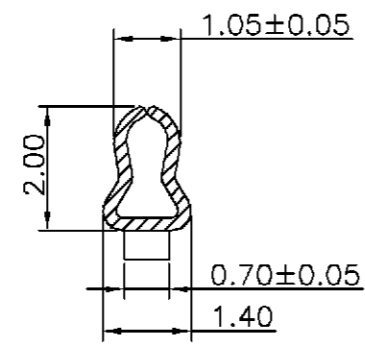

SEC C-C

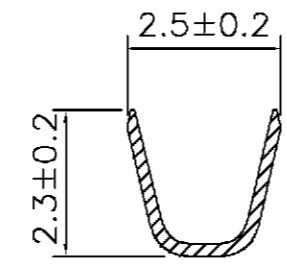

SEC A-A

NOTE:

1. MATERIAL :  
TERMINAL : COPPER ALLOY.
2. FINISH:  
TERMINAL : TIN PLATED ON CONTACT AREA.  
NICKEL UNDERPLATED OVER ALL.
3. QUALIFICATION TEST REPORT: 501-57195.

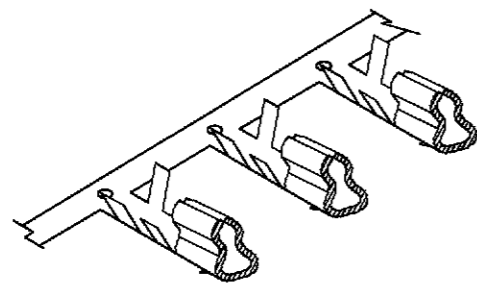

B	CHANGE PACKAGE'S QTY'S	FZ00-0048-04	OH SH	02-APR 2004
A	REVISED DRAWING	FZ00-0167-03	OH AW	28-JUL 2003
O	FIRST RELEASED	FZ00-0009-02	OH JC	10JAN 2002
LTR	REVISION RECORD	ECN	DWN CHK	DATE

DIMENSION : 0 PLC ±0.5 1 PLC ±0.2 2 PLC ±0.1 3 PLC ±0.05 ANGLES ±3'	DWN	O. HU	TYCO HOLDINGS (BERMUDA) VII LTD. TAIWAN BRANCH NAME 2.5mm PITCH EMIX RCPT CRIMP CONTACT		
	31-MAR-2004	S. HOU			
MATERIAL  SEE NOTE	CHK	31-MAR-2004	APVD	T. KE	LOC DW A <sub>3</sub> C-1470223 SCALE -- SHEET 1 OF 2
	31-MAR-2004	31-MAR-2004	PRODUCT SPEC	108-57175	
FINISH  SEE NOTE	APPLICATION SPEC	114-57012	WEIGHT		

1470223-1  
PART NUMBER

NUMBER  
C-1470223

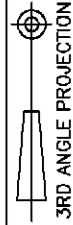

METRIC

THIS INFORMATION IS CONFIDENTIAL AND IS DISCLOSED TO YOU ON CONDITION THAT NO FURTHER DISCLOSURE IS MADE BY YOU TO OTHER THAN AMP PERSONNEL WITHOUT WRITTEN AUTHORIZATION FROM AMP (TAIWAN) LTD. DIMENSIONS IN MILLIMETERS. DO NOT SCALE PRINT.

PRINT DIST  
DW

PULL OUT DIRECTION

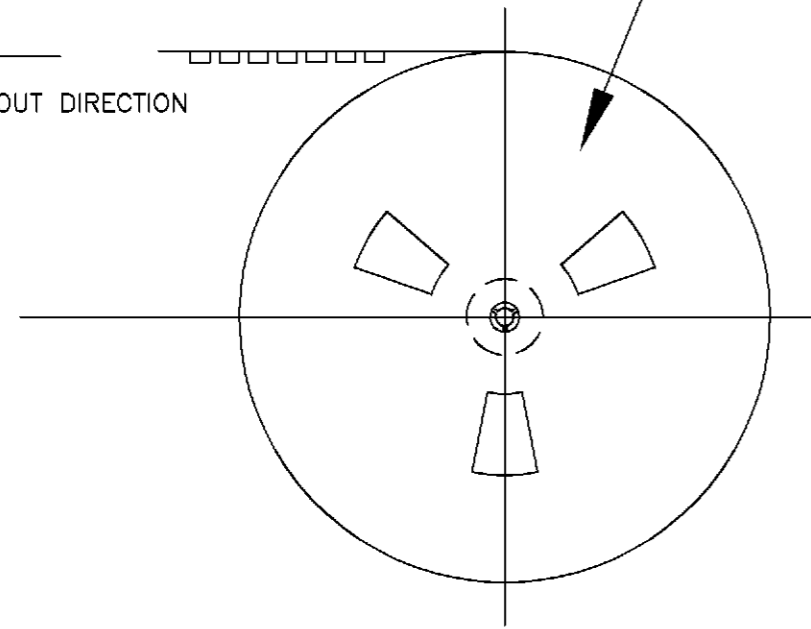

REEL  
10,000 PCS/REEL

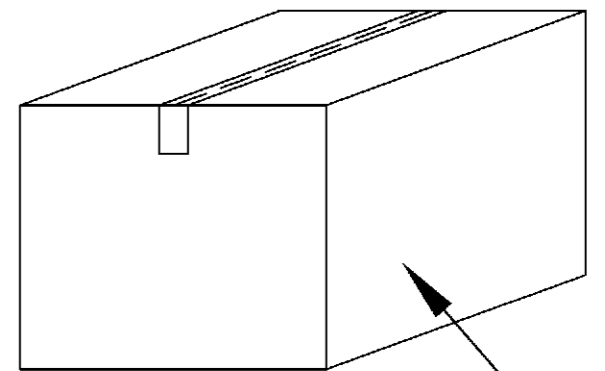
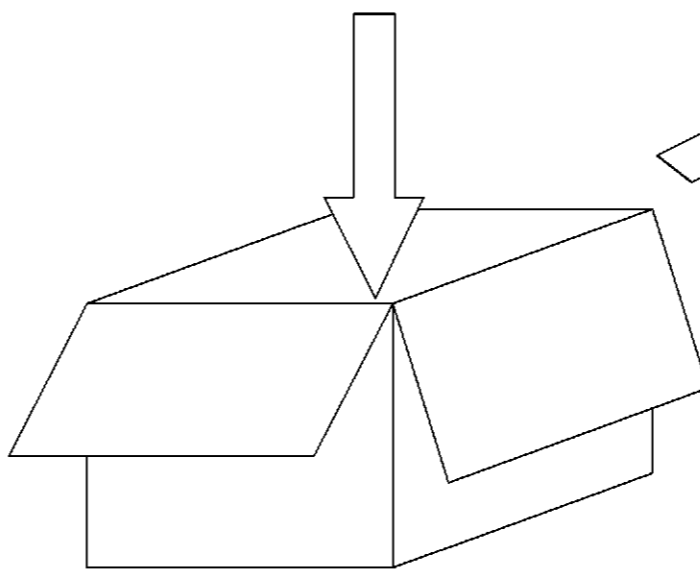
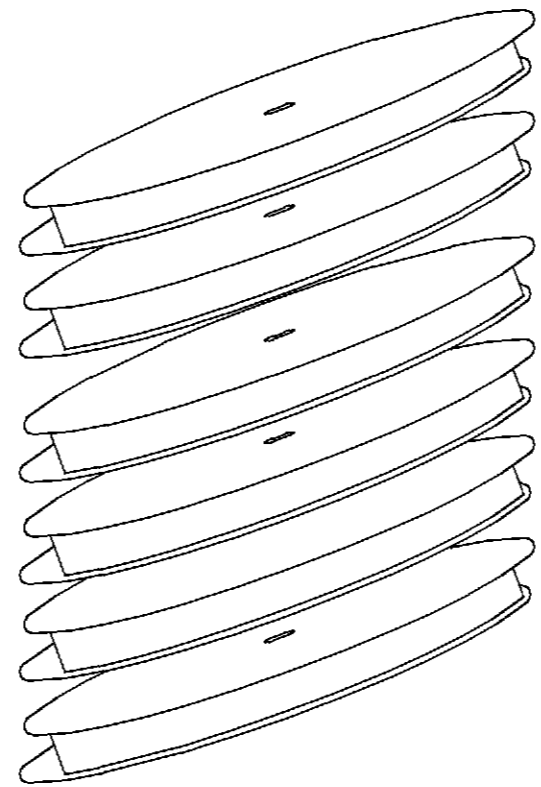

CARTON  
577mm(L)X 577 mm(W)X170mm(H)  
4 REEL/CARTON  
TOTAL: 40,000 PCS  
NET WEIGHT: 2.9Kg  
GROSS WEIGHT: 6.1Kg

LTR	SEE SHEET 1.	ECN	DWN	CHK	DATE
	REVISION RECORD				

DIMENSION : 0 PLC ±0.5 1 PLC ±0.2 2 PLC ±0.1 3 PLC ±0.05 ANGLES ±3'	DWN	O. HU	TYCO HOLDINGS (BERMUDA) VII LTD. TAIWAN BRANCH			
	CHK	S. HOU				
MATERIAL  SEE NOTE	APVD	T. KE	NAME  2.5mm PITCH EMIX RCPT CRIMP CONTACT			
	PRODUCT SPEC	31-MAR-2004				
FINISH  SEE NOTE	APPLICATION SPEC		LOC	SIZE	DRAWING NO	REV
	WEIGHT		DW	A <sub>3</sub>	C-1470223	B
			SCALE	SHEET		
			--	2 OF 2		

CUSTOMER DRAWING

8

7

6

5

4

3

2

1

D

C

B

A