

SE-330AU MANUAL

NEUTRAL-EARTHING-RESISTOR MONITOR

Revision 4-I-101817

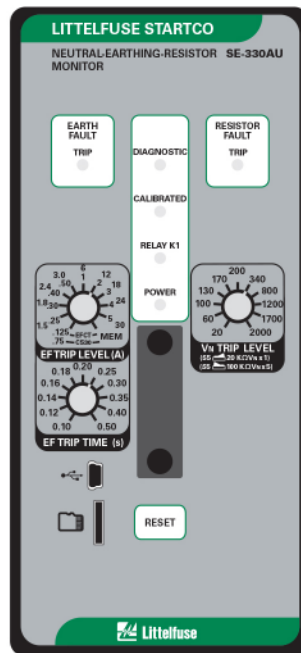

Copyright © 2017 Littelfuse Startco

All rights reserved.

This page intentionally left blank.

TABLE OF CONTENTS

SECTION	PAGE
1 General	1
1.1 Modern Resistance-Earthed Systems	1
1.2 SE-330AU NER Monitoring	1
2 Operation	2
2.1 Settings	2
2.1.1 EF Trip Time	2
2.1.2 EF Trip Level	2
2.1.3 V_N Trip Level	2
2.1.4 Configuration Settings	2
2.1.4.1 Earth-Fault-Trip Latch (S3)	2
2.1.4.2 Resistor-Fault-Trip Latch (S4)	2
2.1.4.3 Sensing-Resistor Selection (S5)	3
2.1.4.4 Frequency (S6)	3
2.1.4.5 Upgrade Mode (S8)	3
2.1.5 Resistor-Fault Trip Time	3
2.1.6 Resistor-Fault Trip Level	3
2.1.7 Geo-Magnetic Filter	3
2.2 Calibration	3
2.3 CT Detection	3
2.4 Trip Indication and Reset	4
2.5 Remote Operation	4
2.6 Relay K1 LED	4
2.7 Unit Healthy Output	4
2.8 Diagnostic LED	4
2.9 Analog Output	4
3 Installation	6
3.1 SE-330AU	6
3.2 Sensing Resistor	6
3.3 Earth-Fault CT	6
3.4 Isolated Earth Connection	24
4 Data Interfaces	25
4.1 SD Card	25
4.1.1 Datalogging	25
4.1.2 Firmware Upgrade	25
4.2 USB Interface	25
4.3 Network Communications	25
5 Troubleshooting	26
6 Technical Specifications	28
6.1 SE-330AU	28
6.2 Sensing Resistors	30
6.3 Current Sensors	31
7 Ordering Information	31
8 Warranty	32
9 Test Procedures	33
9.1 Resistor-Fault Tests	33
9.1.1 Calibration and Open Test	33
9.1.2 Voltage Test	33
9.2 Sensing-Resistor Test	33
9.3 Analog-Output Test	33
9.4 Earth-Fault Performance Test	34
Appendix A SE-330AU Revision History	35

LIST OF FIGURES

FIGURE	PAGE	
1	Configuration Switches	3
2	Analog-Output Connections	4
3	SE-330AU Connection Diagram	7
4	SE-330AU Outline and Panel-Mounting Details	8
5	SE-330AU Outline and Surface-Mounting Details	9
6	SE-IP65CVR-G Weatherproof Cover Outline	10
7	SE-IP65CVR-G Weatherproof Cover Installation	11
8	ER-600VC Sensing Resistor	12
9	SE-MRE-600 Moisture Resistant Enclosure	13
10	ER-600VC Installed in SE-MRE-600	14
11	ER-5KV Sensing Resistor	15
12	ER-5WP Sensing Resistor	16
13	ER-15KV Sensing Resistor	17
14	ER-25KV Sensing Resistor	18
15	ER-35KV Sensing Resistor	19
16	EFCT-1 Earth-Fault Current Sensor	20
17	SE-CS30-70 Earth-Fault Current Sensor	21
18	EFCT-26 and SE-CS30-26 Earth-Fault Current Sensors	22
19	RK-332 Remote Indication and Reset	23
20	PGA-0520 Analog Percent Current Meter	23
21	Simplified Isolated-Earth Connection	24
22	Earth-Fault-Test Circuits	34

LIST OF TABLES

TABLE	PAGE	
1	Typical Values for Tripping Systems	5
2	Earth-Fault-Test Record	34

DISCLAIMER

Specifications are subject to change without notice. Littelfuse Startco is not liable for contingent or consequential damages, or for expenses sustained as a result of incorrect application, incorrect adjustment, or a malfunction.

This page intentionally left blank.

1. GENERAL

1.1 MODERN RESISTANCE-EARTHED SYSTEMS

A high-resistance-earthed system uses a neutral-earthing resistor (NER) with a low let-through current to limit earth-fault current. This is an improvement over low-resistance or solidly-earthed systems because, in those systems, an earth-fault flash hazard exists and an earth fault can result in substantial point-of-fault damage. High-resistance earthing eliminates these problems and modern earth-fault protection operates reliably at low current levels. Furthermore, the probability of an arc-flash incident is significantly reduced in a high-resistance NER system.

NER selection depends on system charging current. System charging current is the capacitive current that flows to earth when a bolted earth fault occurs. This current can be calculated or measured. For small systems, the magnitude of charging current can be conservatively estimated as $\frac{1}{2}$ A per 1,000 kVA on low-voltage systems and 1 A per 1,000 kVA on medium-voltage systems.

Choose an NER with a let-through current larger than the system charging current. Set the pick-up current of earth-fault devices at or below 10% of the NER let-through current for systems up to 1.1 KV and 20% of the NER let through current for systems above 1.1 KV.

Use earth-fault devices with a definite-time characteristic to achieve time coordination. Use the same pick-up current for all earth-fault devices—this value must be larger than the charging current of the largest feeder. Select an NER with a let-through current between five and 10 times the pick-up current of the earth-fault devices.

Do not use an earthing transformer with a low-voltage resistor:

- The combined cost of a transformer and a low-voltage resistor is more than the cost of a resistor rated for line-to-neutral voltage.
- A transformer saturated by an earth fault through a rectifier can make earth-fault protection inoperative.
- Transformer inrush current up to 12 times rated current can cause an earth-fault voltage larger than expected.
- A parallel transformer winding makes it difficult to monitor NER continuity.
- A transformer can provide the inductance necessary to cause ferroresonance if the NER opens.

Following these guidelines will reduce the flash hazard, reduce point-of-fault damage, achieve reliable earth-fault protection, and ensure a stable system not subject to ferroresonance.

1.2 SE-330AU NER MONITORING

The SE-330AU is a microprocessor-based neutral-earthing-resistor monitor that detects NER failures and earth faults in resistance-earthed systems. The SE-330AU measures NER resistance, NER current, and transformer or generator neutral-to-earth voltage. The components required to monitor an NER are an SE-330AU, an ER-series sensing resistor, and a current transformer (CT).

Power-circuit elements, other than neutral-connected NER's, that purposefully connect the power system to earth may not be compatible with SE-330AU NER monitoring. These elements include single-phase earthing transformers, earthed-wye-primary potential transformers (PT's), and earthed-wye-primary power transformers.

The SE-330AU continuously measures NER resistance in an unfaulted system. It will trip on resistor fault if NER resistance varies from its calibrated value. When an earth fault occurs, voltage is present on the neutral and NER current will flow if the NER is healthy. The SE-330AU will trip on earth fault if fault current exceeds the EF TRIP LEVEL setting for an interval greater than the EF TRIP TIME setting. However, if the NER fails and creates an open circuit during an earth fault, it is possible for fault resistance to satisfy the NER resistance measurement. To detect this double-fault condition, the SE-330AU measures neutral voltage. If neutral voltage exceeds the V_N TRIP LEVEL setting, and if NER current is less than 5% of the current transformer (CT) rating, the SE-330AU will trip on resistor fault. If the resistor-fault circuit is tripped and the neutral voltage exceeds the V_N TRIP LEVEL setting for an interval greater than the EF TRIP TIME setting, the earth-fault circuit will also trip. Earth-fault current is sensed by a sensitive CT (EFCT-x or SE-CS30-x). The trip level of the earth-fault circuit is adjustable from 0.125 to 5 A for the EFCT-x and 0.75 to 30 A for the SE-CS30-x. Trip time is adjustable from 0.1 to 0.5 seconds. Open-CT detection is provided with a fixed 2-second time delay.

The SE-330AU has four output relays. Relay K1 is the trip relay. Relays K2 and K3 provide earth-fault and resistor-fault indication. K4 is a solid-state relay that provides UNIT HEALTHY indication. Relay K1 operates in the fail-safe mode for undervoltage applications.

Additional features include LED trip indication, trip memory, front-panel and remote reset, 4-20-mA analog output, trip event recorder, USB local communications, microSD™ data logging, and optional network communications.

The SE-330AU is compatible with lockout earth-fault protection devices—the on line phase-to-earth resistance added by coupling components must be above the SE-330AU NER-failure-detection resistance.

The SE-330AU provides additional features over the SE-330AU legacy model (revision 01 or less):

- When the trip level is set to MEM, the earth-fault trip setting is defined by an internal non-volatile memory variable. Range is 2 to 100% in 1% increments of the CT-primary rating.
- Indication relays can be set to fail-safe or non-fail-safe.
- The number of trip records has been increased to 100 and includes date and time stamping.
- A microSD™ card interface can be used for long-term data logging and firmware updates. A microSD™ card and a microSD-to-SD adapter is included. See Section 4.1.
- For ease of connection to new devices, the RS-232 interface has been replaced by a Mini B USB port.
- Dual Ethernet ports are available with support for fiber-optic and RJ45 interfaces.
- The IEC 61850 protocol has been added.

2. OPERATION

2.1 SETTINGS

2.1.1 EF TRIP TIME

EF TRIP TIME (definite time) is adjustable from 0.1 to 0.5 seconds. Time-coordinated earth-fault protection requires this setting to be longer than the trip times of downstream earth-fault devices.

A trip-time accumulator provides an earth-fault memory function for detection of intermittent faults. The accumulated time increases when an earth fault is detected and decreases when an earth fault is not detected. A trip will eventually occur when the time for fault current above the trip level is greater than the time for fault current below the trip level.

2.1.2 EF TRIP LEVEL

The SE-330AU uses a Discrete-Fourier Transform (DFT) Algorithm to measure the fundamental component of NER current.

Choose an NER let-through current and an earth-fault trip level according to the guidelines in Section 1.1.

Earth-fault current is sensed by a sensitive CT (EFCT-x or SE-CS30-x). The trip level of the earth-fault circuit is adjustable from 0.125 to 5 A for the EFCT-x and 0.75 to 30 A for the SE-CS30-x.

When EF TRIP LEVEL is set to MEM, the earth-fault setting stored in non-volatile memory is used. This parameter must be set using a PC running the SE-MON330 software connected to the USB interface. The setting range is 2 to 100% of CT-primary rating in 1% increments. For example, if the MEM parameter is set to 15% (default), the trip level will be 0.75 A or 4.5 A when using the EFCT-x or SE-CS30-x respectively. Typical values are shown in Table 1. For other systems, refer to the NER Monitor Set-Point Assistant at www.littelfuse.com/relayscontrols. The Set-Point Assistant is included with the SE-MON330 software.

2.1.3 V_N TRIP LEVEL

The SE-330AU uses a DFT algorithm to measure the fundamental component of neutral voltage (V_N).

If neutral voltage is greater than the V_N TRIP LEVEL setting for the duration of the resistor-fault trip time and earth-fault current is less than 5% of the CT rating, the SE-330AU will trip on resistor fault. If the resistor-fault circuit is tripped and the neutral voltage exceeds the V_N TRIP LEVEL setting for an interval greater than the EF TRIP TIME setting, the earth-fault circuit will also trip.

The V_N TRIP LEVEL range is 20 to 2,000 V with switch S5 in the 20-k Ω (V_{x1}) position, and the range is 100 to 10,000 V with switch S5 in the 100-k Ω (V_{x5}) position. Calculate the voltage across the NER when NER current is equal to the pick-up current of the earth-fault circuit. Set the V_N TRIP LEVEL at the next largest value. See Fig. 1 and Section 2.1.4.3.

Typical values are shown in Table 1. For an NER resistance greater than 2 k Ω , use a 100-k Ω sensing resistor. For other systems, refer to the NER Monitor Set-Point Assistant at www.littelfuse.com/relayscontrols.

NOTE: A resistor-fault trip is held off if the earth-fault current is above 5% of the CT rating.

2.1.4 CONFIGURATION SETTINGS

Eight configuration switches (S1 to S8) and a calibration button are located behind the access cover on the front panel. See Fig. 1.

2.1.4.1 EARTH-FAULT-TRIP LATCH (S3)

Set switch S3 to select latching or non-latching earth-fault-circuit operation. See Section 2.4.

2.1.4.2 RESISTOR-FAULT-TRIP LATCH (S4)

Set switch S4 to select latching or non-latching resistor-fault-circuit operation. See Section 2.4

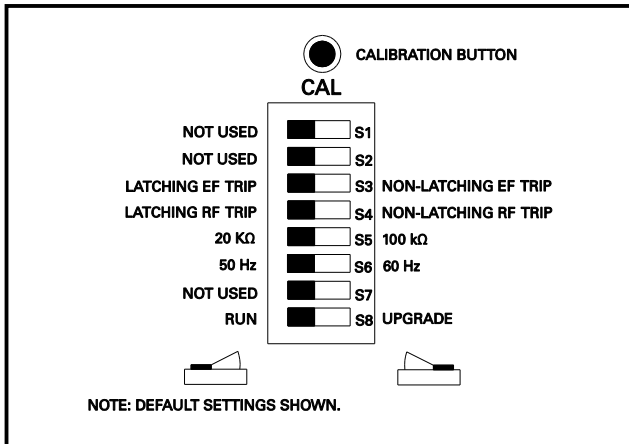

FIGURE 1. Configuration Switches.

2.1.4.3 SENSING-RESISTOR SELECTION (S5)

Set switch S5 to the resistance of the sensing resistor. For the ER-600VC, ER-5KV, and ER-5WP select 20 kΩ. For the ER-15KV, ER-25KV, and ER-35KV, select 100 kΩ. Switch S5 sets the V_N TRIP LEVEL range. See Section 2.1.3.

2.1.4.4 FREQUENCY (S6)

Set switch S6 to 50 or 60 Hz to tune the digital filter to the line frequency of the monitored system.

2.1.4.5 UPGRADE MODE (S8)

The microSD™ card is used for firmware upgrades. See Section 4.1.2 for upgrade instructions.

NOTE: An upgrade causes an SE-330AU restart and this may cycle the output relays.

2.1.5 RESISTOR-FAULT TRIP TIME

The resistor-fault trip time can be adjusted from 12 (default) to 60 seconds using the SE-MON330 software or via network communications.

2.1.6 RESISTOR-FAULT TRIP LEVEL

The resistor-fault trip level can be adjusted using the SE-MON330 software or via network communications. See Section 6.1.

2.1.7 GEO-MAGNETIC FILTER

A low-frequency earth current can be caused by the Earth's magnetic field and from charged clouds passing overhead during a thunderstorm. In some rare conditions, this can cause a false resistor-fault trip. Enabling the geo-magnetic filter and increasing the resistor-fault trip time can help counteract these effects.

A trip time of 30 seconds is recommended when the geo-magnetic filter is enabled.

The geo-magnetic filter is disabled by default, but can be enabled using the SE-MON330 software or via network communications.

2.2 CALIBRATION

The SE-330AU measures the resistance change of the NER relative to the NER-resistance value determined at the time of calibration. When the resistance change is greater than a threshold amount (500 Ω for 20-kΩ systems, 2,500 Ω for 100-kΩ systems), a resistor-fault trip occurs. Calibrate the SE-330AU on new installations, if the NER is changed, or if the sensing resistor is changed.

The CALIBRATION button is located behind the access cover on the front panel, and it is recessed to prevent inadvertent activation.

NOTE: Calibration must be performed with the SE-330AU connected to the sensing resistor and NER of the installed system.

NOTE: Where used, coupling components for lockout earth-fault protection devices must be disconnected from the supply during calibration.

To calibrate, press and hold the CALIBRATION button until the green CALIBRATED LED turns off and returns to on (if the LED is already off, press and hold until the LED turns on). Calibration takes approximately two seconds. If calibration is not successful, a resistor-fault trip occurs, the RESISTOR FAULT TRIP LED will be on, the CALIBRATED LED will be off, and the DIAGNOSTIC LED will flash the calibration-error code. See Section 2.8.

The SE-330AU may be calibrated remotely using the SE-MON330 software with the USB interface or the communications options.

If latching resistor fault (switch S4) is selected, the calibration-error code flashes until RESET is pressed even if the CALIBRATED LED is on.

The calibration value is stored in non-volatile memory.

2.3 CT DETECTION

The SE-330AU monitors the continuity of the CT circuit. When an open CT circuit is detected for two seconds, the SE-330AU will trip on earth fault and the diagnostic LED will flash the CT-Detection-Error code. See Section 2.8. The CT-Detection-Error code remains until CT-circuit continuity is detected and RESET is pressed. If supply voltage is cycled, earth-fault trip indication is not reset but the CT-Detection-Error indication is reset. CT-Detection-Error indication will resume after two seconds if CT-circuit continuity is not detected.

2.4 TRIP INDICATION AND RESET

Red LED's and indication relays indicate earth-fault and resistor-fault trips. The indication relays K2 (EF) and K3 (RF) operate in fail-safe or non-fail-safe mode. The default is non-fail-safe mode. In this mode, the relays are energized when a fault occurs. The relay mode setting is stored in non-volatile memory and can be set using the SE-MON330 software or network communications.

When a trip occurs with latching operation selected, the SE-330AU remains tripped until reset with the front panel button or the remote-reset input. See Sections 2.1.4.1 and 2.1.4.2. Terminals 15 and 16 are provided for remote reset as shown in Fig. 3. The reset circuit responds only to a momentary closure so that a jammed or shorted button does not prevent a trip. The front-panel RESET button is inoperative when terminal 15 is connected to terminal 16. If non-latching operation is selected, trips and corresponding indication automatically reset when the fault clears. Resistor-fault-trip reset can take up to one second.

The red DIAGNOSTIC LED annunciates latched calibration error and remote trips. See Section 2.8.

When supply voltage is applied, the SE-330AU returns to its state prior to loss of supply voltage. A resistor-fault trip-memory trip can take up to three seconds after SE-330AU power-up.

2.5 REMOTE OPERATION

Relays K2 and K3 can be used for remote indication, and terminals 15 and 16 are provided for remote reset. RK-332 Remote Indication and Reset components are shown in Fig. 19. Connect them as shown in Fig. 3. RK-332 components are not polarity sensitive.

Indication relays can be set to fail-safe or non-fail-safe operation using the SE-MON330 software or network communications. The default mode is non-fail-safe. In non-fail-safe mode, relays energize on fault.

Network-enabled SE-330AU's can be remotely tripped, reset, and calibrated by the network master. The red DIAGNOSTIC LED indicates a network-initiated trip. See Section 2.8. Refer to the appropriate SE-330AU communications manual.

2.6 RELAY K1 LED

The yellow RELAY K1 LED follows the state of relay K1 and is on when K1 is energized (contact closed).

2.7 UNIT HEALTHY OUTPUT

UNIT HEALTHY relay K4 is energized when the processor is operating. It can be ordered with N.O. or N.C. contacts. See Section 7.

NOTE: The K4 output changes state momentarily during a processor reset.

NOTE: K4-contact rating is 100 mA maximum.

2.8 DIAGNOSTIC LED

The DIAGNOSTIC LED is used to annunciate trips without individual LED indication. The number of short LED pulses between two long pulses indicates the cause of the trip.

By default, both critical and non-critical diagnostic flash codes are shown. Non-critical diagnostic codes include SD Card status and USB Error status. All other diagnostic codes are considered critical.

Starting with SE-330AU firmware version 2.60 and SE-MON330 software version 3.8, the SE-330AU can be configured to show only critical diagnostic codes. In this configuration, non-critical diagnostic codes will not be indicated with the DIAGNOSTIC LED.

Diagnostic messages are always visible with the SE-MON330.

See Sections 4.2 and 5.

2.9 ANALOG OUTPUT

An isolated 4–20-mA output indicates NER current with full-scale output corresponding to the CT rating. An internal 24-Vdc supply allows the analog output to be connected as a self-powered output. Power from an external supply is required for loop-powered operation. See Fig. 2. The PGA-0520 analog meter can be panel-mounted to display the NER current. See Fig. 20 and Section 7.

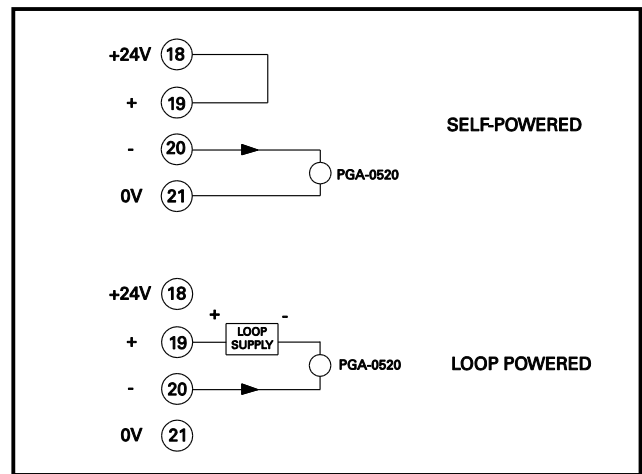

FIGURE 2. Analog-Output Connections.

TABLE 1. TYPICAL VALUES FOR TRIPPING SYSTEMS

SYSTEM VOLTAGE (VOLTS)		NEUTRAL-EARTHING RESISTOR		EARTH-FAULT TRIP LEVEL (AMPERES)		V _N TRIP LEVEL (VOLTS)	SENSING RESISTOR	S5
LINE TO LINE	LINE TO NEUTRAL	CURRENT (AMPERES)	RESISTANCE (OHMS)	EFCT-X (5-A RATING)	SE-CS30-X (30-A RATING)			
110 (3)	55	5	11	0.5	(1)	20	ER-600VC	20 kΩ
120 (3)	60	5	12	0.5	(1)	20	ER-600VC	20 kΩ
110	64	5	13	0.5	(1)	20	ER-600VC	20 kΩ
127	73	5	15	0.5	(1)	20	ER-600VC	20 kΩ
240 (3)	120	5	24	0.5	(1)	20	ER-600VC	20 kΩ
240	139	5	28	0.5	(1)	20	ER-600VC	20 kΩ
270	156	5	31	0.5	(1)	20	ER-600VC	20 kΩ
415	240	5	48	0.5	(1)	60	ER-600VC	20 kΩ
433	250	5	50	0.5	(1)	60	ER-600VC	20 kΩ
690	398	5	80	0.5	(1)	60	ER-600VC	20 kΩ
970	560	5	112	0.5	(1)	60	ER-5KV	20 kΩ
1,000	575	5	115	0.5	(1)	60	ER-5KV	20 kΩ
1,050	605	5	121	0.5	(1)	100	ER-5KV	20 kΩ
1,100	635	5	127	0.5	(1)	100	ER-5KV	20 kΩ
1,140	658	5	132	0.5	(1)	100	ER-5KV	20 kΩ
3,300	1,905	5	381	0.5	(1)	200	ER-5KV	20 kΩ
6,600	3,810	5	762	0.5	(1)	500	ER-15KV	100 kΩ
6,600	3,810	10	381	1.0	0.75	500	ER-15KV	100 kΩ
6,600	3,810	25	152	2.0	1.5	500	ER-15KV	100 kΩ
11,000	6,350	5	1,270	0.5	(1)	650	ER-15KV	100 kΩ
11,000	6,350	10	635	1.0	0.75	650	ER-15KV	100 kΩ
11,000	6,350	20	318	2.0	1.5	650	ER-15KV	100 kΩ
11,000	6,350	25	254	2.0	2.4	650	ER-15KV	100 kΩ
22,000	12,700	5	2,540	0.5	(1)	1,700	ER-25KV	100 kΩ
22,000	12,700	10	1,270	1.0	0.75	1,700	ER-25KV	100 kΩ
22,000	12,700	20	635	2.0	1.5	1,700	ER-25KV	100 kΩ
22,000	12,700	25	508	2.0	2.4	1,700	ER-25KV	100 kΩ
22,000	12,700	50	254	(2)	24	8,500	ER-25KV	100 kΩ
33,000	19,050	50	380	(2)	24	10,000	ER-35KV	100 kΩ

- (1) Minimum setting is 0.75 A. Use EFCT-x for AS/NZS 2081:2002 compliance.
- (2) Maximum setting is 5 A. AS/NZS 2081:2002 allows 25 A.
- (3) Single phase, centre tap.

3. INSTALLATION

3.1 SE-330AU

Outline and panel-cutout dimensions for the SE-330AU are shown in Fig. 4. To panel mount the SE-330AU, insert it through the panel cutout and secure it with the four included 8-32 locknuts and flat washers. If an optional SE-IP65CVR-G Hinged Cover is used, follow the included installation instructions. See Figs 6 and 7.

All connections to the SE-330AU are made with plug-in, wire-clamping terminal blocks. Each plug-in terminal block can be secured to the SE-330AU by two captive screws for reliable connections.

Outline dimensions and mounting details for surface mounting the SE-330AU are shown in Fig. 5. Fasten the optional SE-330-SMA Surface-Mount Adapter to the mounting surface and make connections to the adapter terminal blocks. Follow Fig. 5 instructions to mount or remove the SE-330AU.

Connect terminal 7 (G) to earth and connect terminal 6 (R) to the sensing-resistor R terminal.

Use terminal 1 (L1) as the line terminal on ac systems, or the positive terminal on dc systems. Use terminal 2 (L2/N) as the neutral terminal on ac systems or the negative terminal on dc systems. Connect terminal 3 (\oplus) to earth.

NOTE: Disconnect terminal 1 (L1) and terminal 2 (L2/N) before performing dielectric strength testing of the control panel.

NOTE: Connections to terminals 4 (SPG) and 5 (SPGA) are not required when using the SE-330AU hardware revision 10 and higher. However, it is recommended to connect terminal 4 to terminal 5 to maintain backwards compatibility with the older SE-330AU series (hardware revision 01 and lower).

3.2 SENSING RESISTOR

Outline and mounting details for the ER-600VC, ER-5KV, ER-5WP, ER-15KV, ER-25KV, and ER-35KV sensing resistors are shown in Figs. 8, 11, 12, 13, 14 and 15. Install the NER and the sensing resistor near the transformer or generator. An optional SE-MRE-600 Moisture Resistant Enclosure is available for applications which may expose an ER-600VC to moisture. See Figs 9 and 10. The weather-protected ER-5WP shown in Fig. 12 is an ER-5KV with moisture-resistant terminal covers. Use an ER-5WP in applications in which it might be exposed to moisture. The ER-15KV, ER-25KV, and ER-35KV include moisture-resistant terminal covers. Use suitable water-tight fittings. Connect terminal G to earth. Pass the sensing-resistor-to-neutral conductor and the NER-to-neutral conductor through the earth-fault-CT window as shown in Fig. 3. Separately connect sensing-resistor terminal N and the NER to the neutral to include neutral connections in the monitored loop. Alternatively, if the NER connection to

system neutral need not be monitored, connect terminal N to the NER neutral terminal.

If an earth fault in the sensing-resistor conductor is unlikely, a minimal loss of protection will result if it does not pass through the earth-fault-CT window. See Fig. 3.

NOTE: Voltage at terminal N rises to line-to-neutral voltage when an earth fault occurs. The same clearances are required for sensing resistors as for NER's.

NOTE: A parallel earth path created by moisture can result in a false resistor-fault trip. Moisture sources include wind-driven rain or snow, and condensation. Sensing-resistor terminal R and its connection to SE-330AU terminal R, including interposing terminal blocks, must remain dry.

NOTE: The neutral-to-sensing-resistor-terminal-N connection is not a neutral conductor. Since current through this conductor is always less than 250 mA, a 1.5 mm² conductor insulated to the system voltage is more than sufficient.

NOTE: For outdoor installations, sensing resistors must be in an IP14 enclosure.

3.3 EARTH-FAULT CT

Select and install an earth-fault CT that will provide the desired trip level. Typically, the CT-primary rating should be approximately equal to the NER let-through-current rating. This provides an appropriate EF TRIP LEVEL setting range and analog-output scaling. The primary rating of the EFCT-x is 5 A and the primary rating of the SE-CS30-x is 30 A. See Sections 2.1.2 and 2.9.

Outline and mounting details for the sensitive EFCT-x and SE-CS30-x current sensors are shown in Figs. 16, 17, and 18. Earth-fault-CT connections and the typical earth-fault-CT location are shown in Fig. 3. If an earth fault in the NER is unlikely, a minimal loss of protection will result if the earth-fault CT monitors the NER connection to earth rather than its connection to neutral.

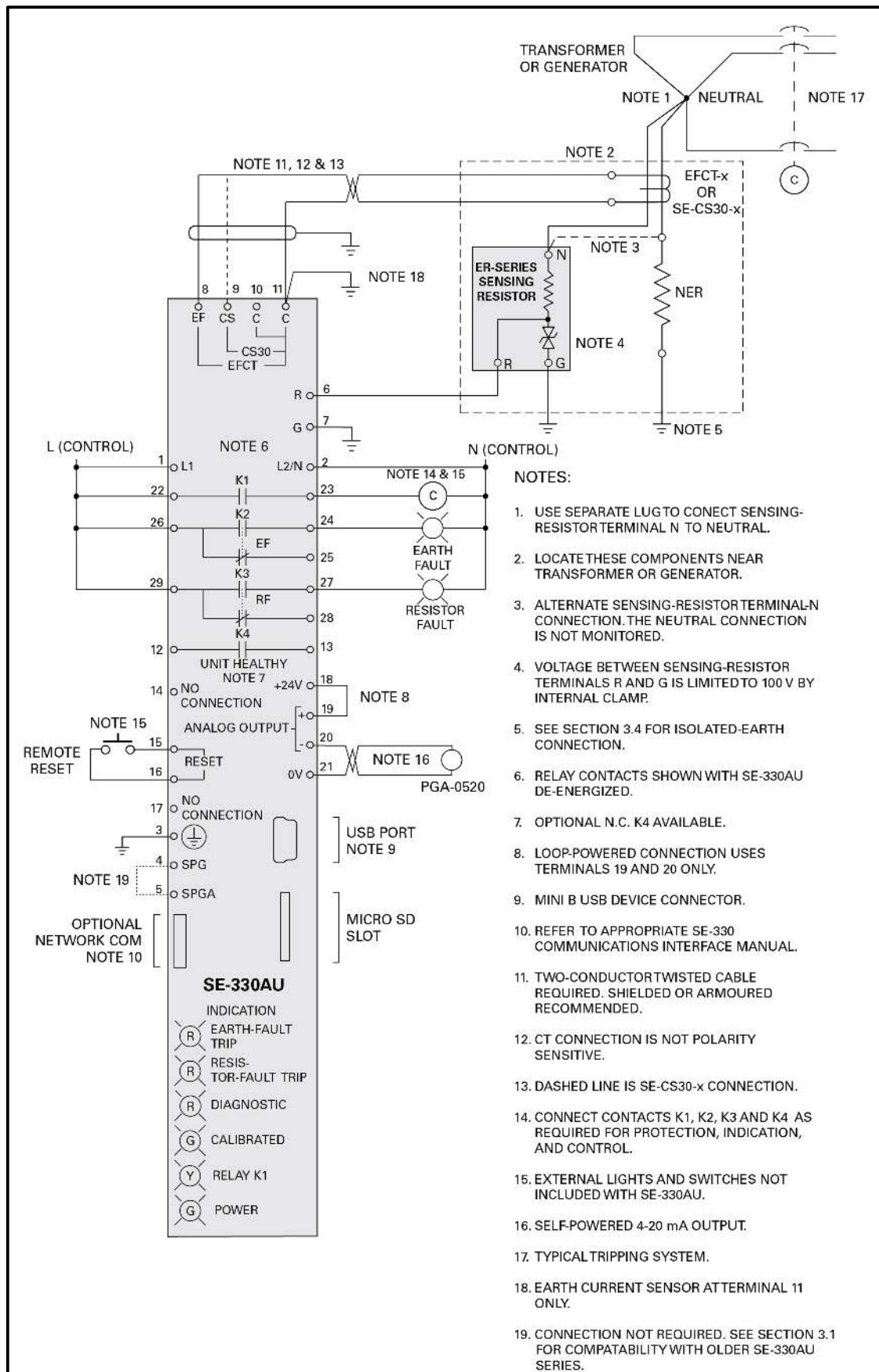

FIGURE 3. SE-330AU Connection Diagram.

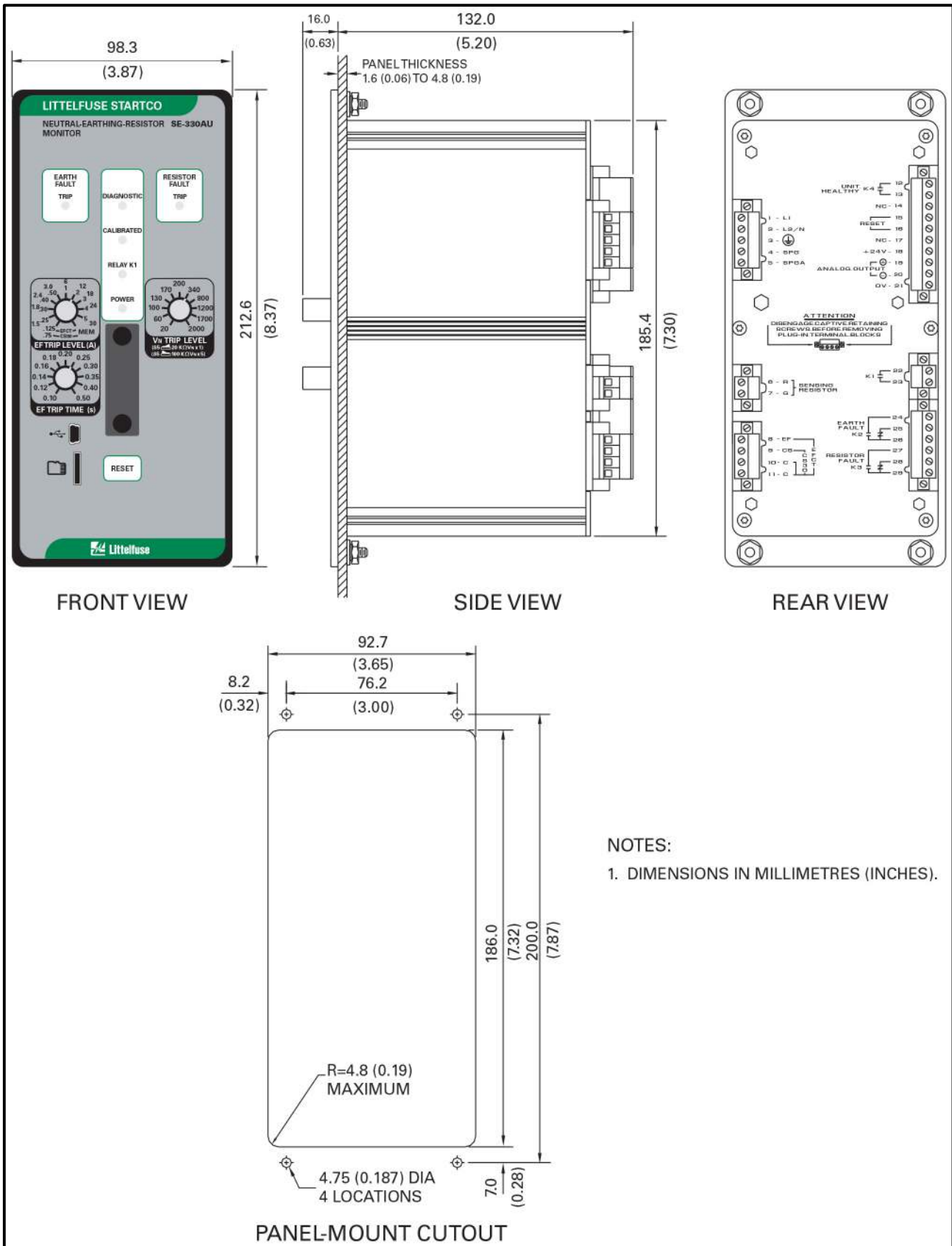

FIGURE 4. SE-330AU Outline and Panel-Mounting Details.

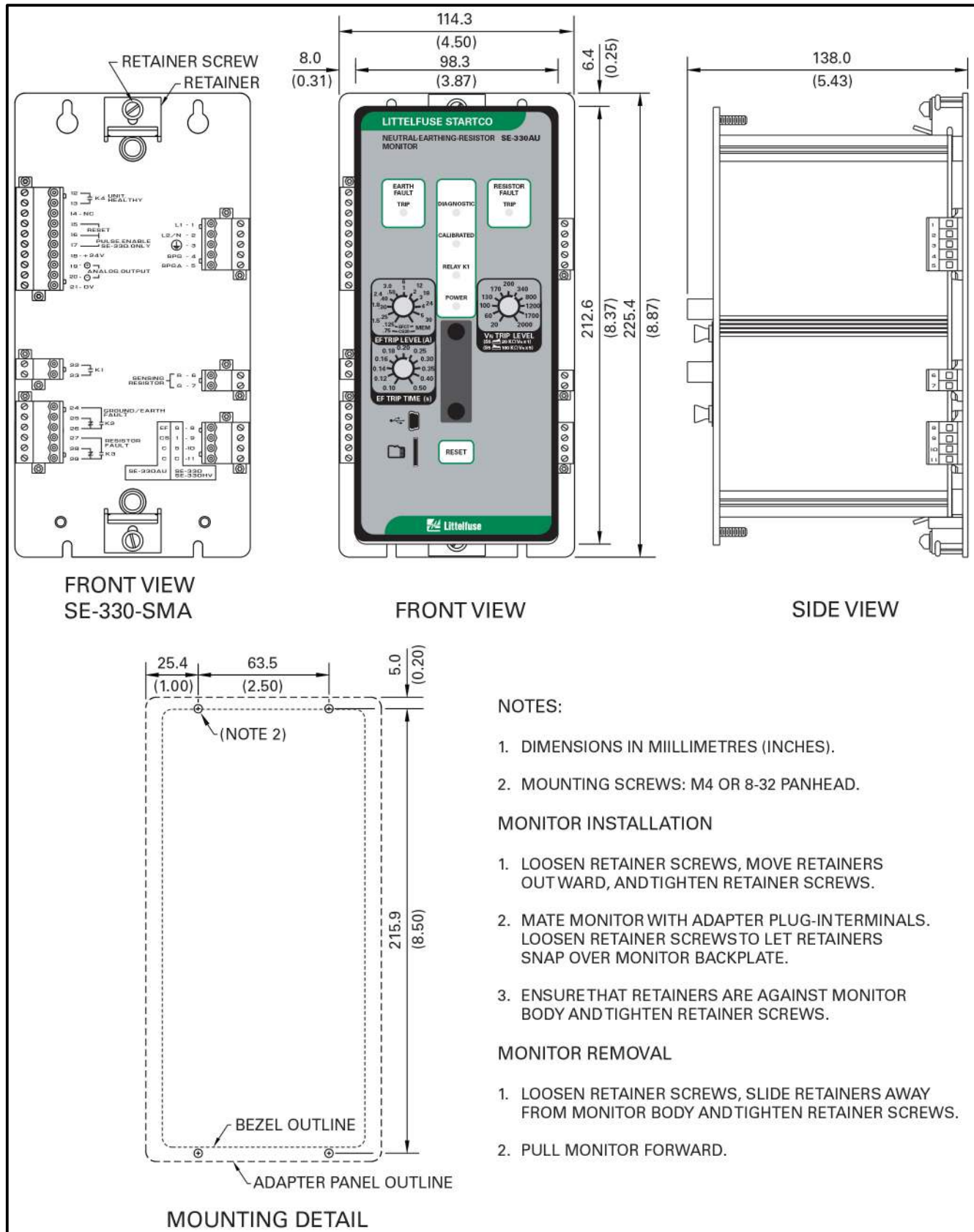

FIGURE 5. SE-330AU Outline and Surface-Mounting Details.

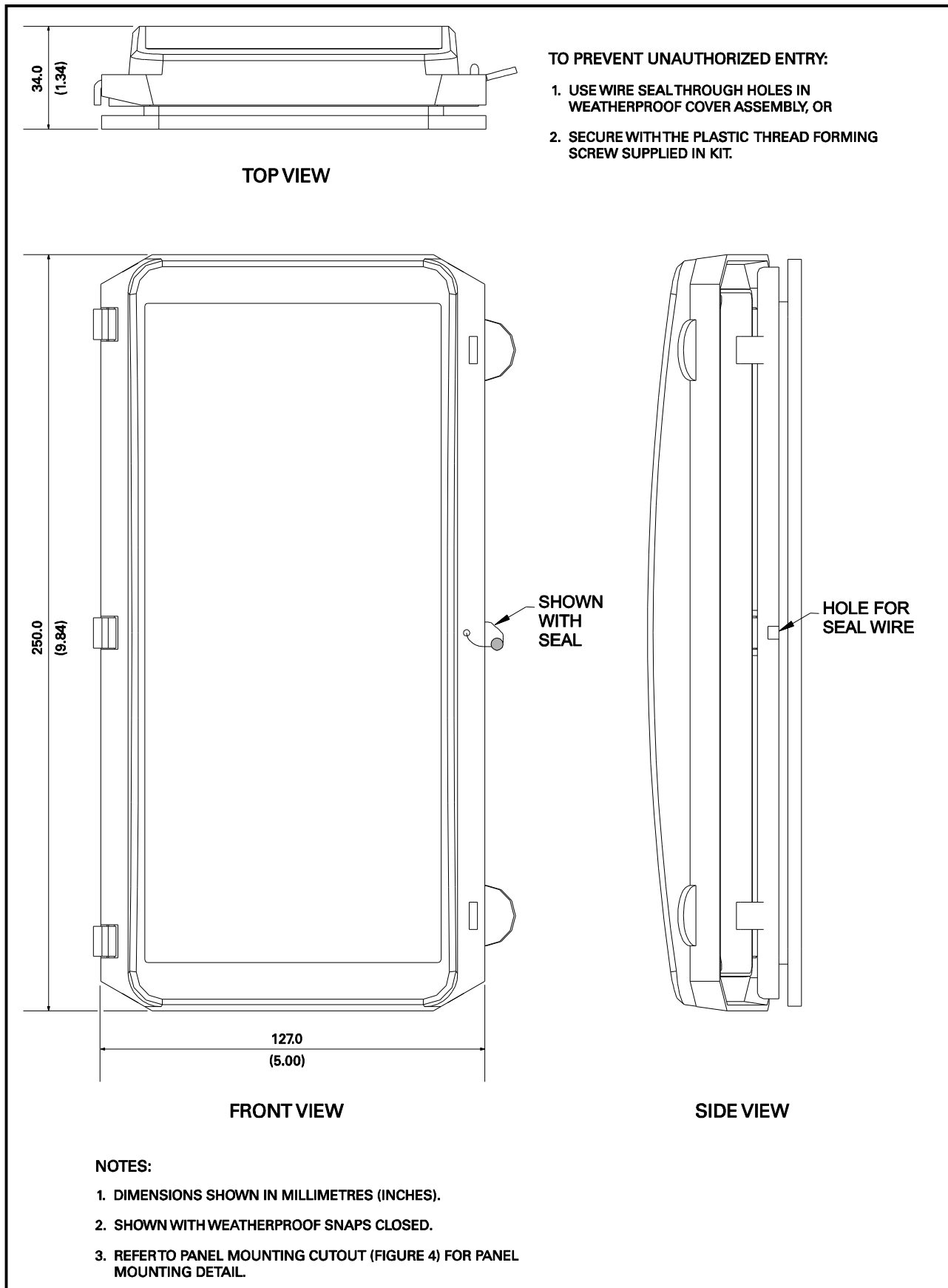

FIGURE 6. SE-IP65CVR-G Weatherproof Cover Outline.

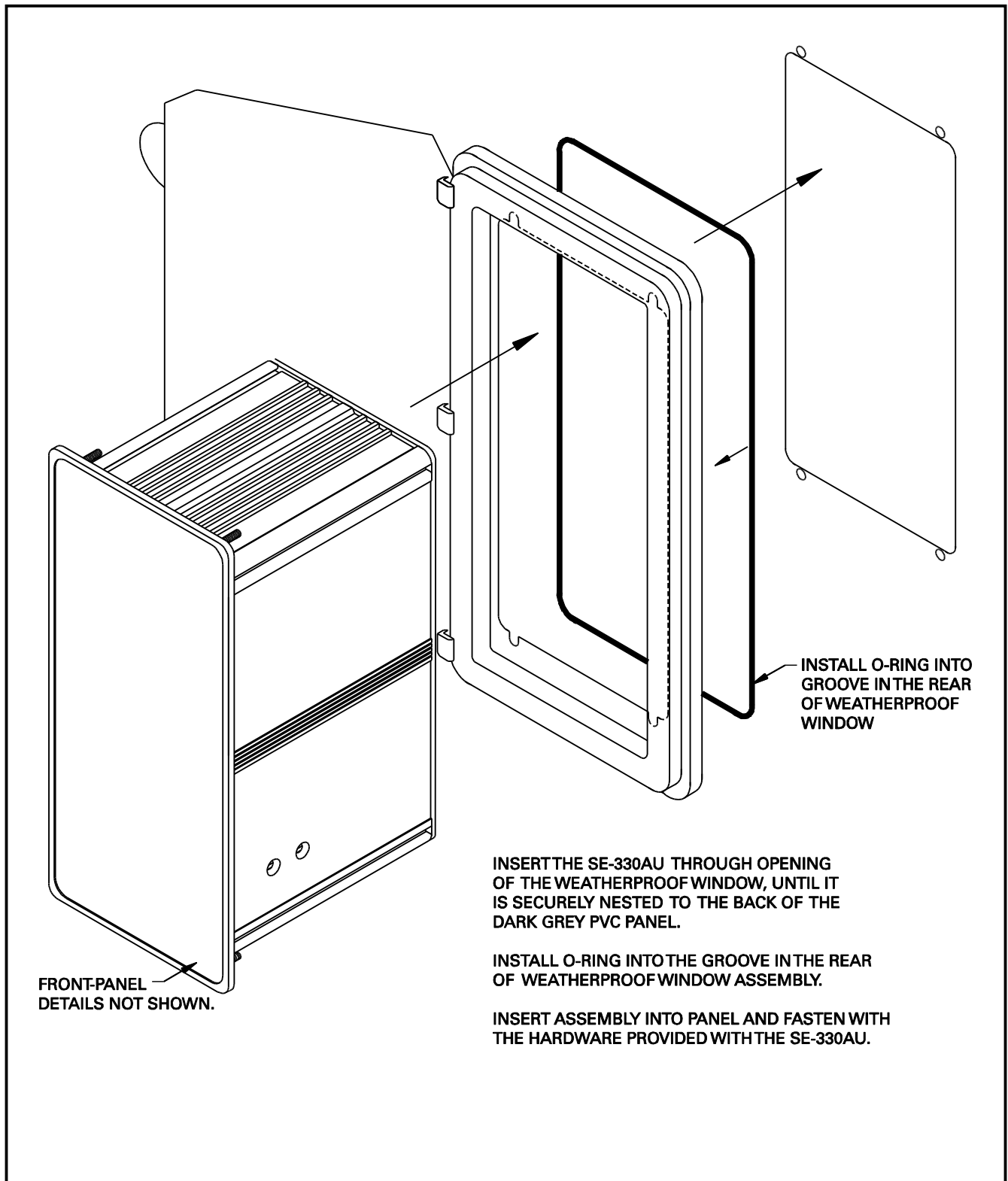

FIGURE 7. SE-IP65CVR-G Weatherproof Cover Installation.

RATINGS:

MAXIMUM VOLTAGE . 600 Vac

MAXIMUM CURRENT . 30 mA

RESISTANCE 20 kΩ

THERMAL:

600 Vac 6 MINUTES ON,
60 MINUTES OFF

420 Vac CONTINUOUS

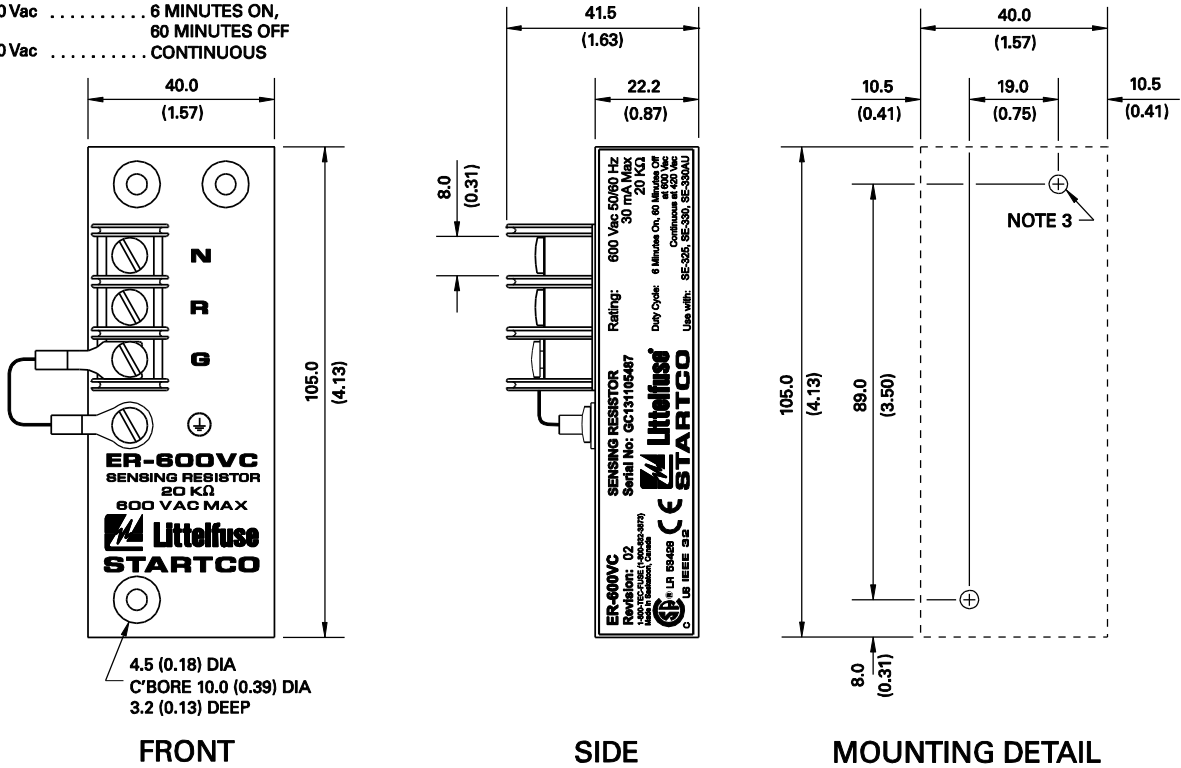

NOTES:

1. DIMENSIONS IN MILLIMETRES (INCHES).
2. TERMINAL-BLOCK SCREWS: 6-32 x 0.25.
3. MOUNTING SCREWS: M4 OR 8-32.
4. ON REVISION 2 UNITS ENCLOSURE IS ELECTRICALLY CONNECTED TO TERMINAL G THROUGH JUMPER FROM TERMINAL G TO ⊕ SCREW. THIS CONNECTION MAY BE REMOVED FOR DIELECTRIC STRENGTH TESTING. ENSURE THAT THE JUMPER IS INSTALLED AFTER TESTING.
5. ON REVISION 1 UNITS, ⊕ SCREW IS NOT PRESENT AND ENCLOSURE IS ELECTRICALLY CONNECTED TO TERMINAL G.
6. NOT ALL CERTIFICATIONS SHOWN.

FIGURE 8. ER-600VC Sensing Resistor.

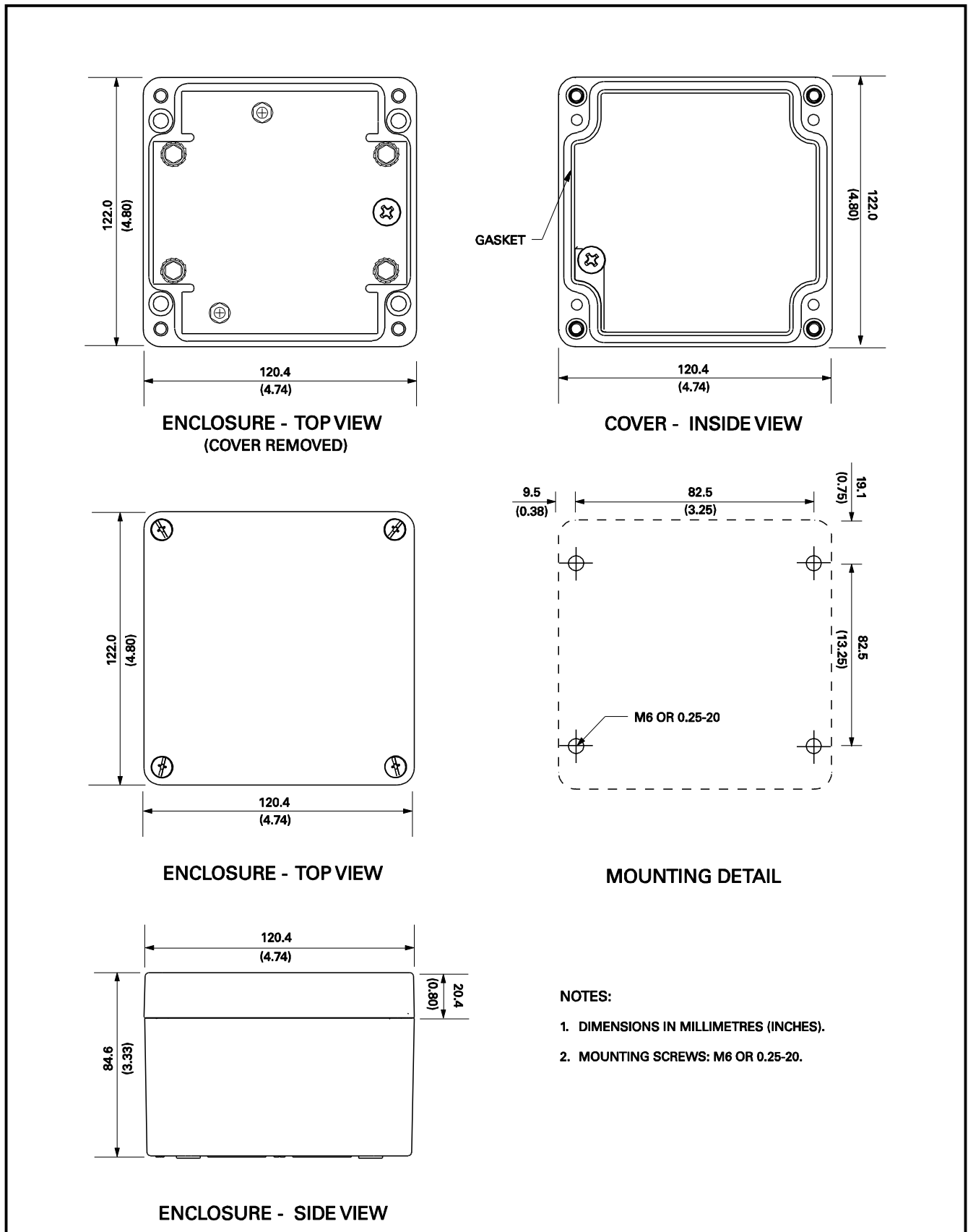

FIGURE 9. SE-MRE-600 Moisture Resistant Enclosure.

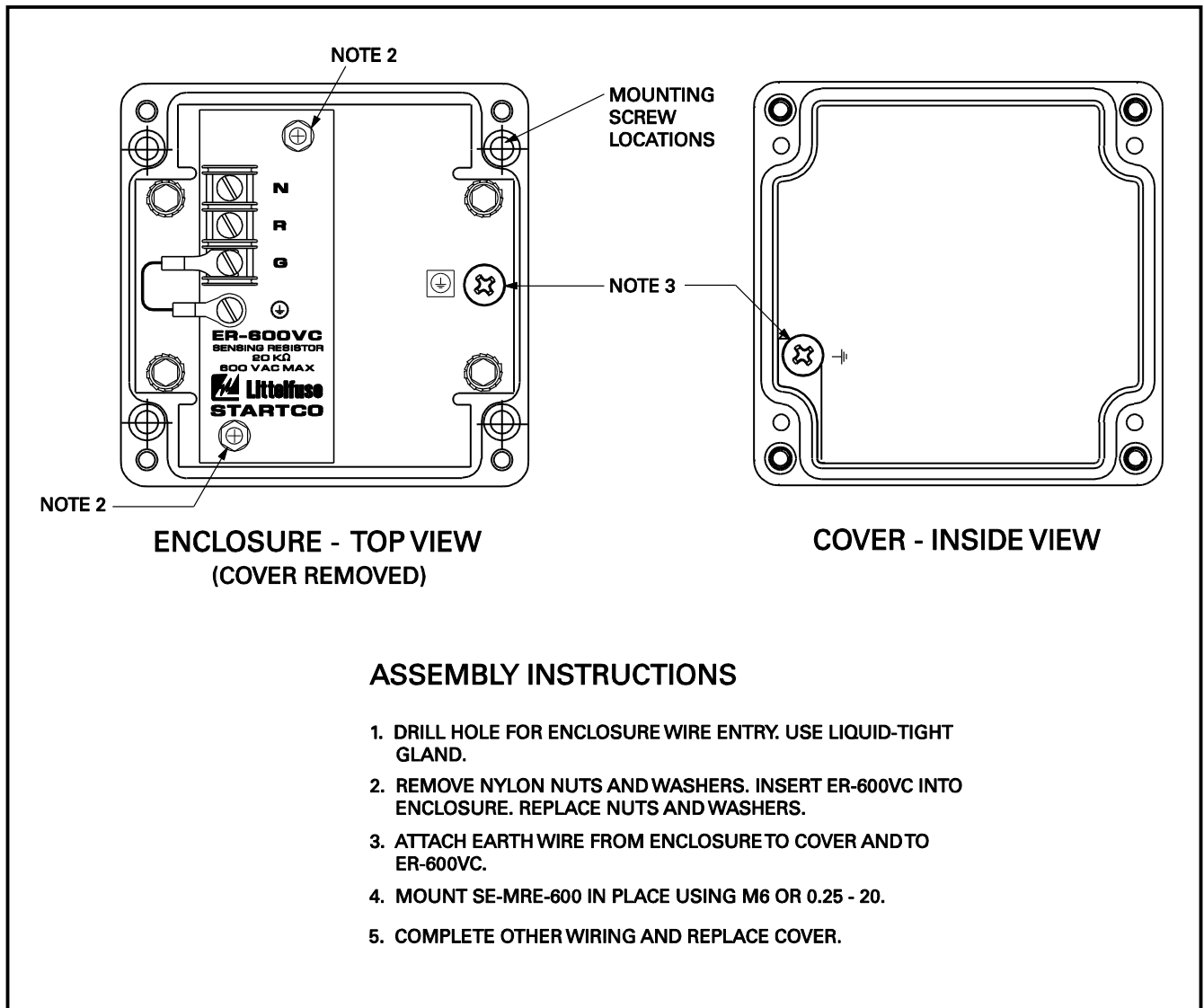

FIGURE 10. ER-600VC Installed in SE-MRE-600.

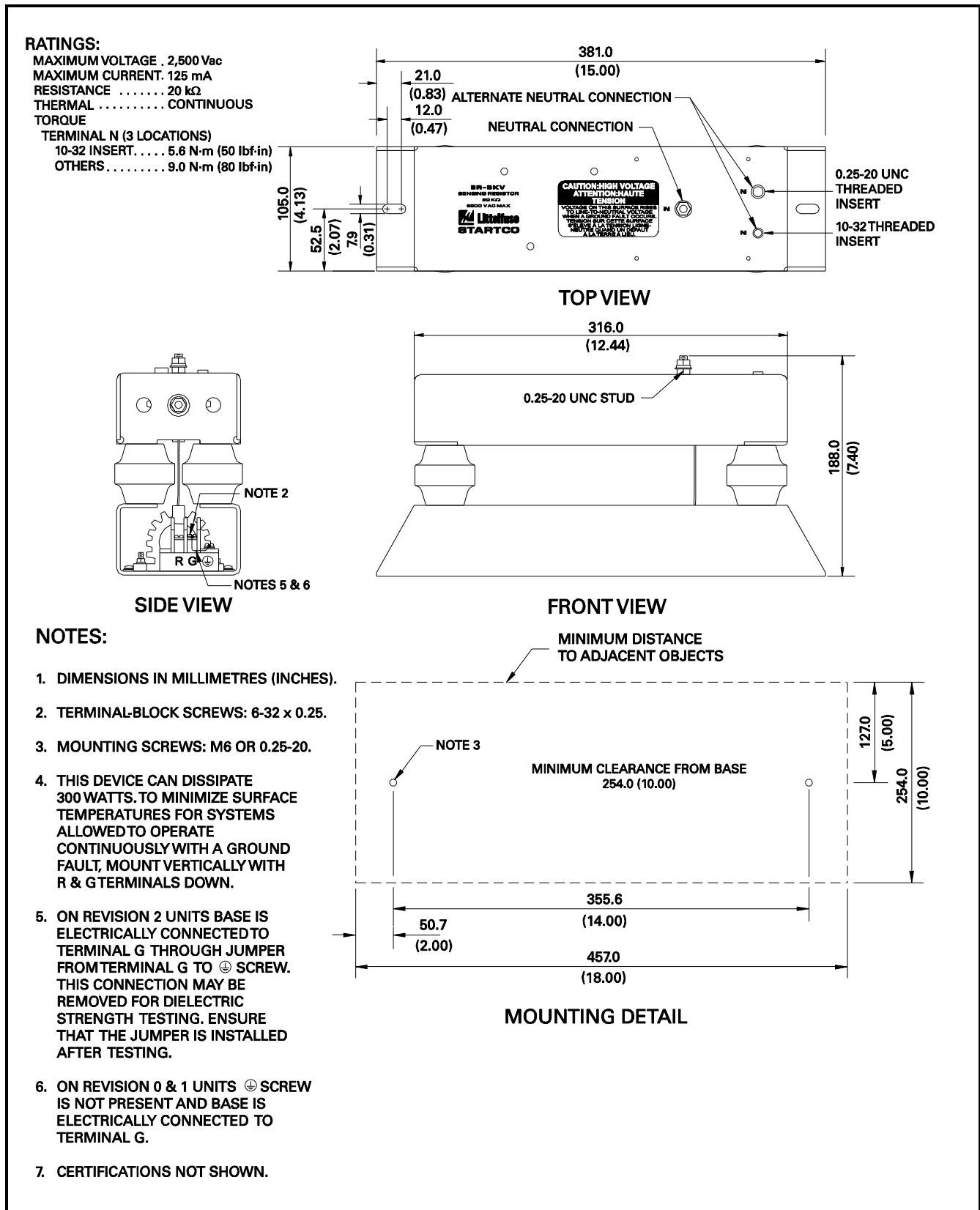
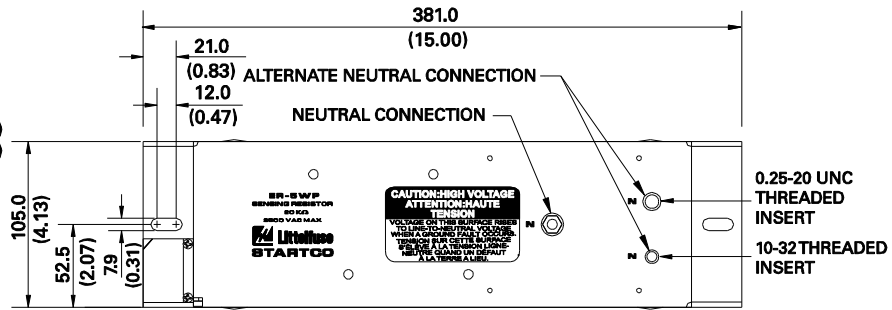

FIGURE 11. ER-5KV Sensing Resistor.

RATINGS:

- MAXIMUM VOLTAGE . . . 2,500 Vac
- MAXIMUM CURRENT: 125 mA
- RESISTANCE 20 kΩ
- THERMAL CONTINUOUS
- TORQUE
- TERMINAL N (3 LOCATIONS)
- 10-32 INSERT 5.6 N·m (50 lbf-in)
- OTHERS 9.0 N·m (80 lbf-in)



TOP VIEW

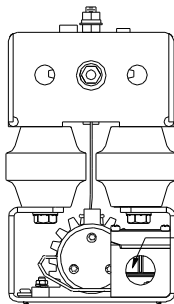

SIDE VIEW

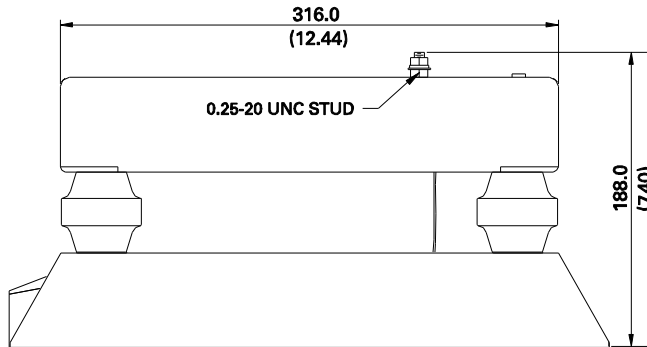

FRONT VIEW

NOTES:

1. DIMENSIONS IN MILLIMETRES (INCHES).
2. TERMINAL-BLOCK SCREWS: 6-32 x 0.25 CABLE ACCESS OPENING IS 1/2 NPT. USE A LIQUID-TIGHT FITTING FOR CABLE ENTRY.
3. MOUNTING SCREWS: M6 OR 0.25-20.
4. THIS DEVICE CAN DISSIPATE 300 WATTS. TO MINIMIZE SURFACE TEMPERATURES FOR SYSTEMS ALLOWED TO OPERATE CONTINUOUSLY WITH A GROUND FAULT, MOUNT VERTICALLY WITH R & G TERMINALS DOWN.
5. BASE IS ELECTRICALLY CONNECTED TO TERMINAL G THROUGH JUMPER FROM TERMINAL G TO ⊕ SCREW. THIS CONNECTION MAY BE REMOVED FOR DIELECTRIC STRENGTH TESTING. ENSURE THAT THE JUMPER IS INSTALLED AFTER TESTING.
6. CERTIFICATIONS NOT SHOWN.

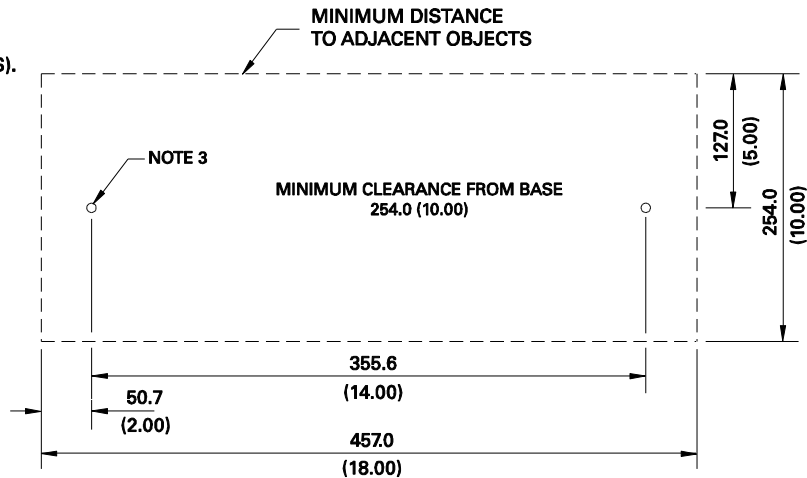

MOUNTING DETAIL

FIGURE 12. ER-5WP Sensing Resistor.

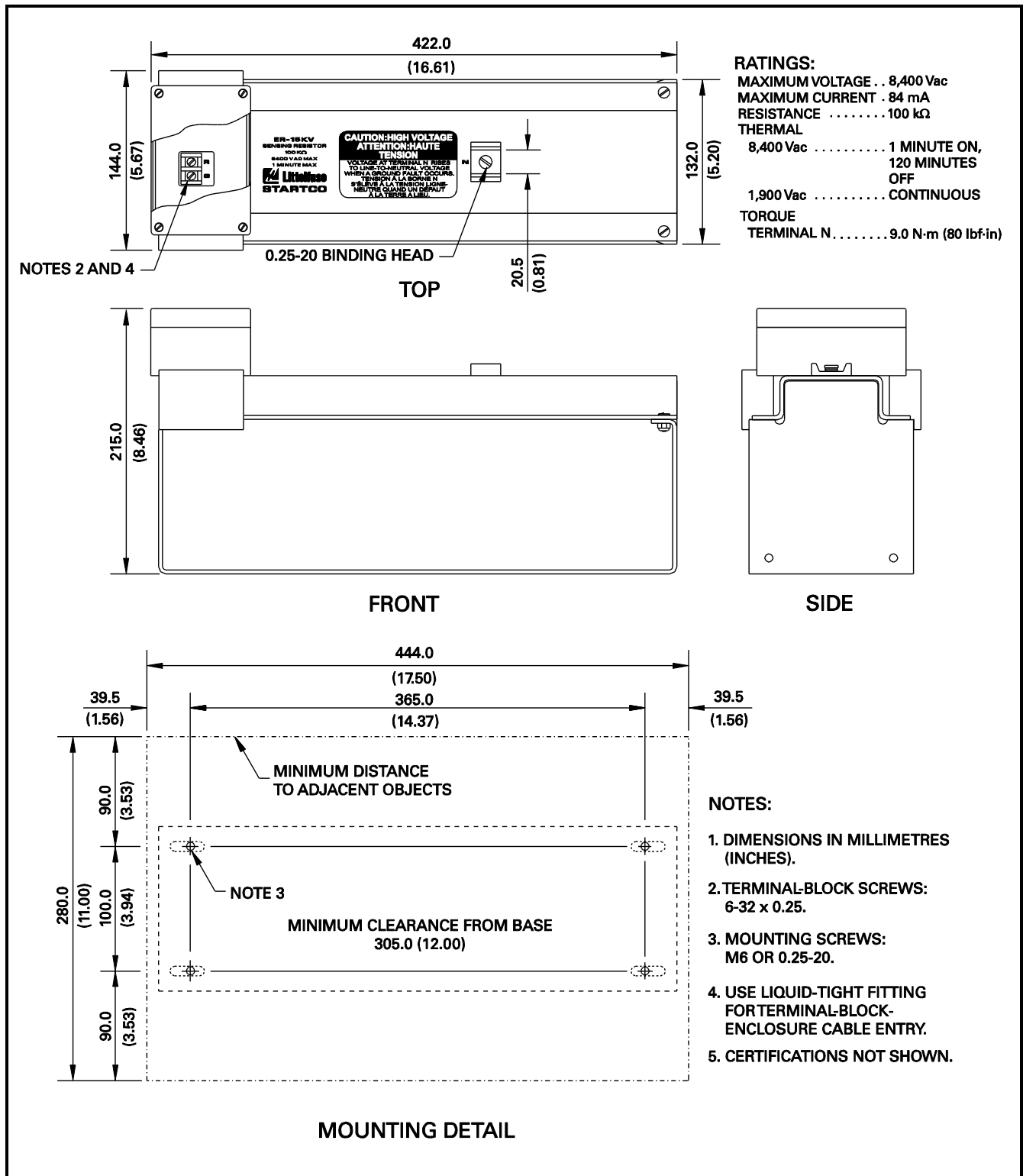

FIGURE 13. ER-15KV Sensing Resistor.

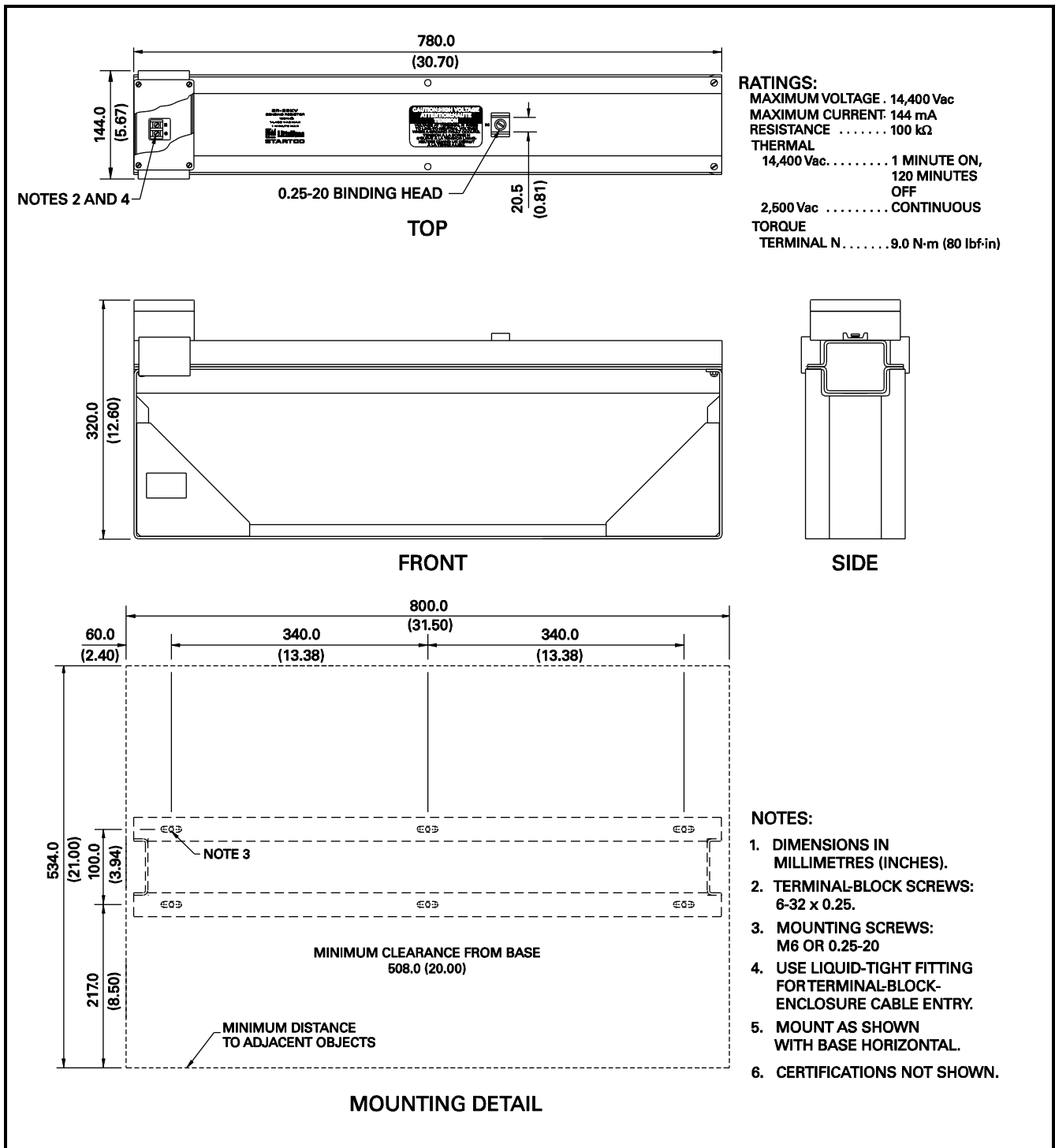

FIGURE 14. ER-25KV Sensing Resistor.

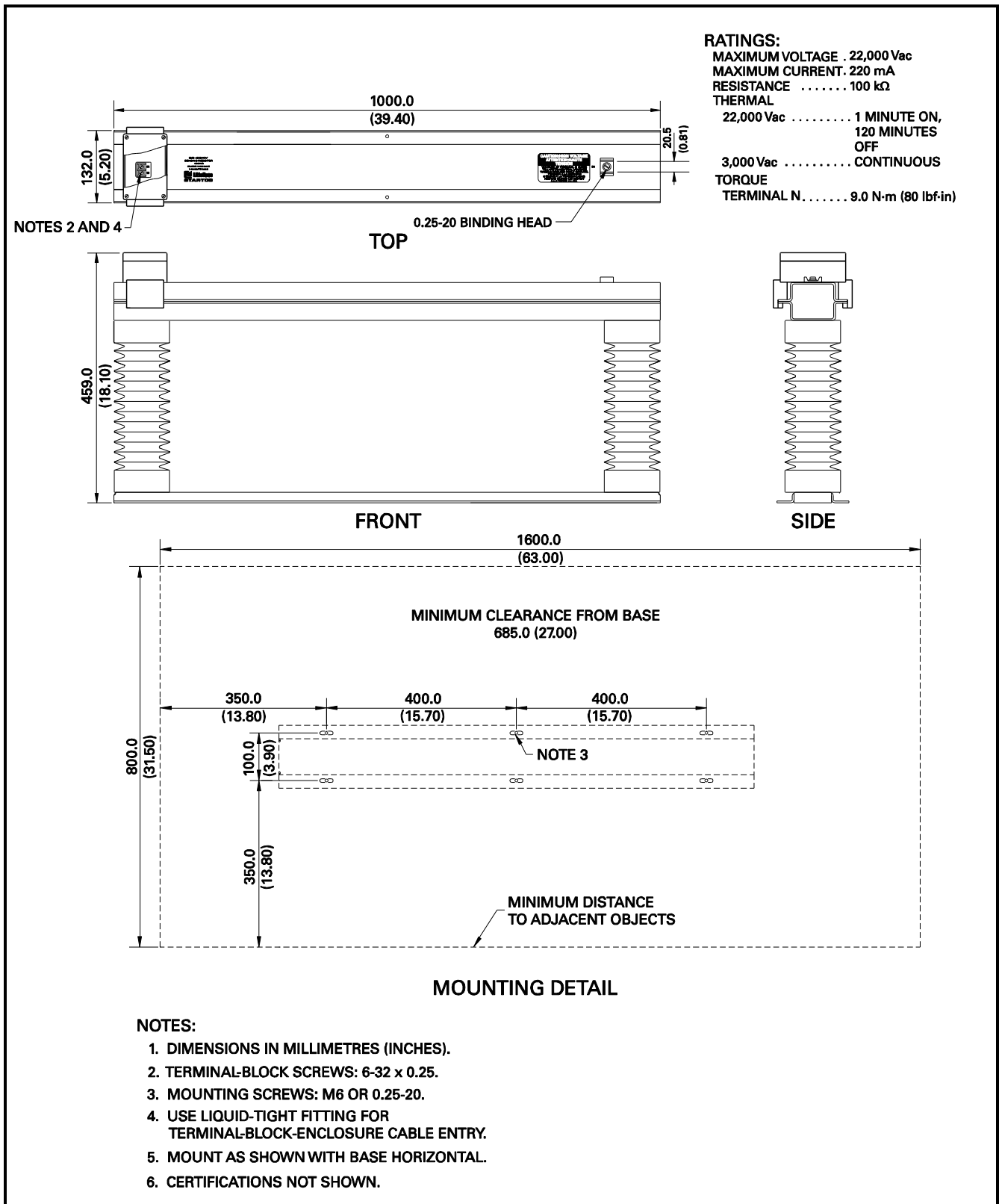

FIGURE 15. ER-35KV Sensing Resistor.

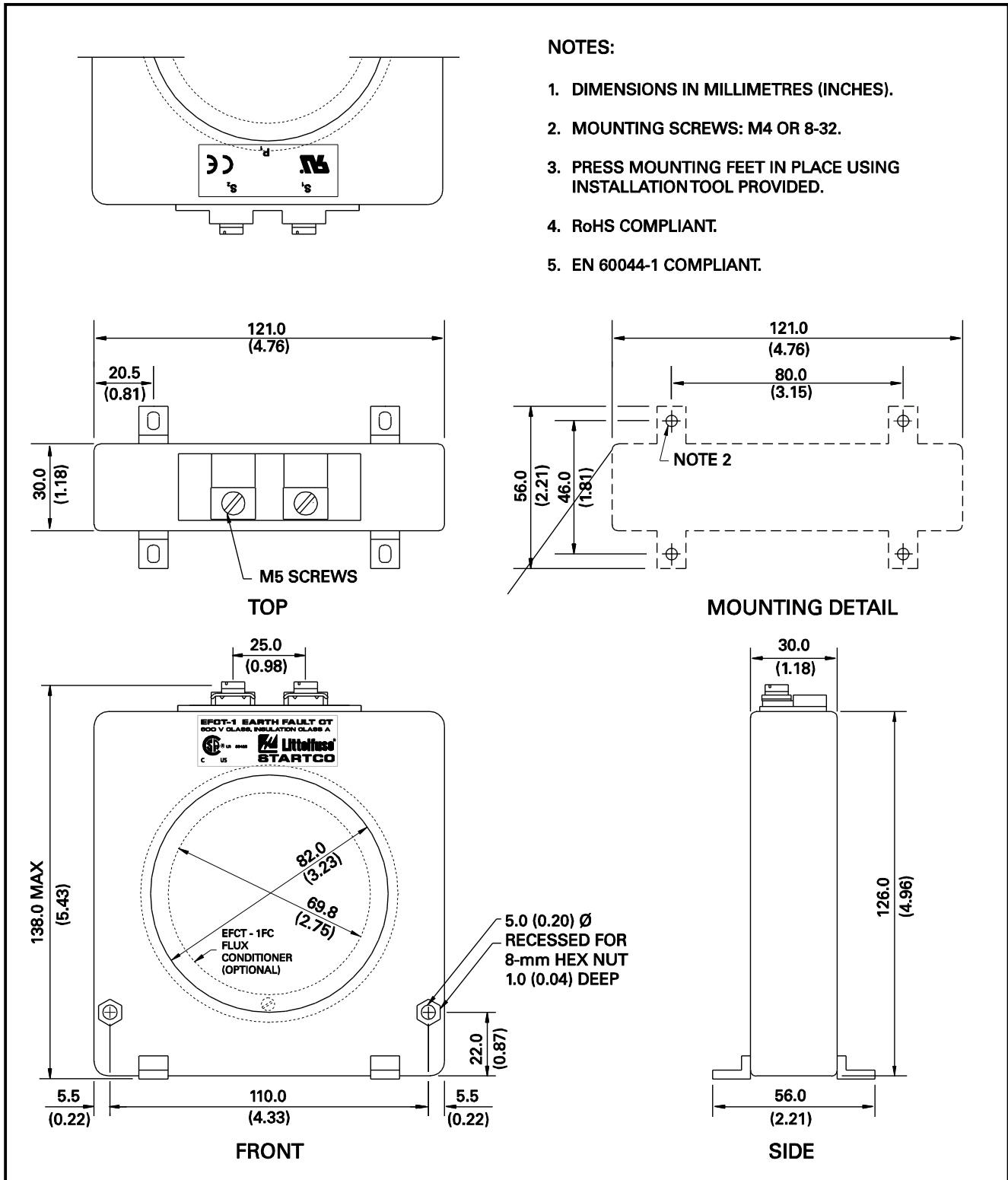

FIGURE 16. EFCT-1 Earth-Fault Current Sensor.

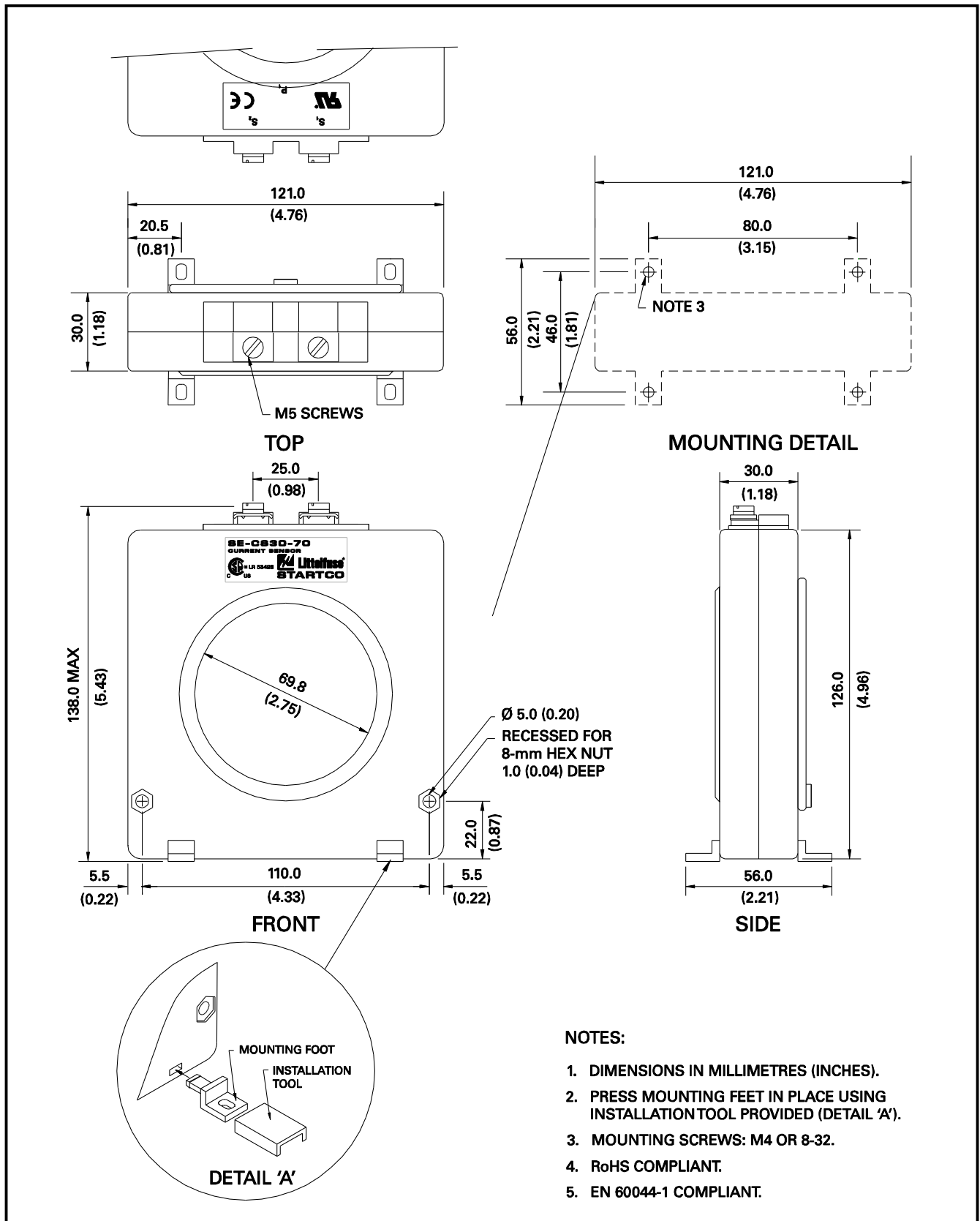

FIGURE 17. SE-CS30-70 Earth-Fault Current Sensor.

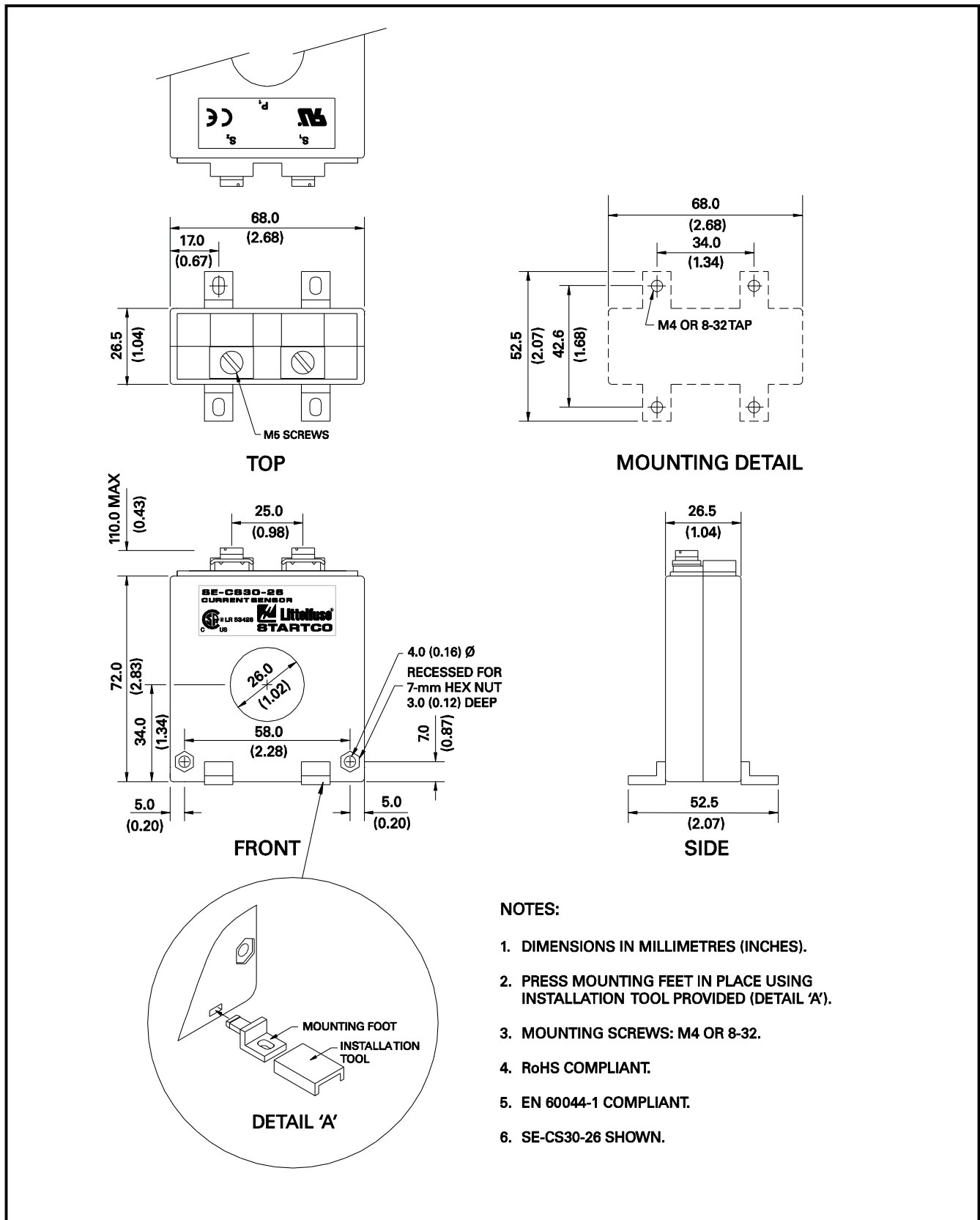

FIGURE 18. EFCT-26 and SE-CS30-26 Earth-Fault Current Sensors.

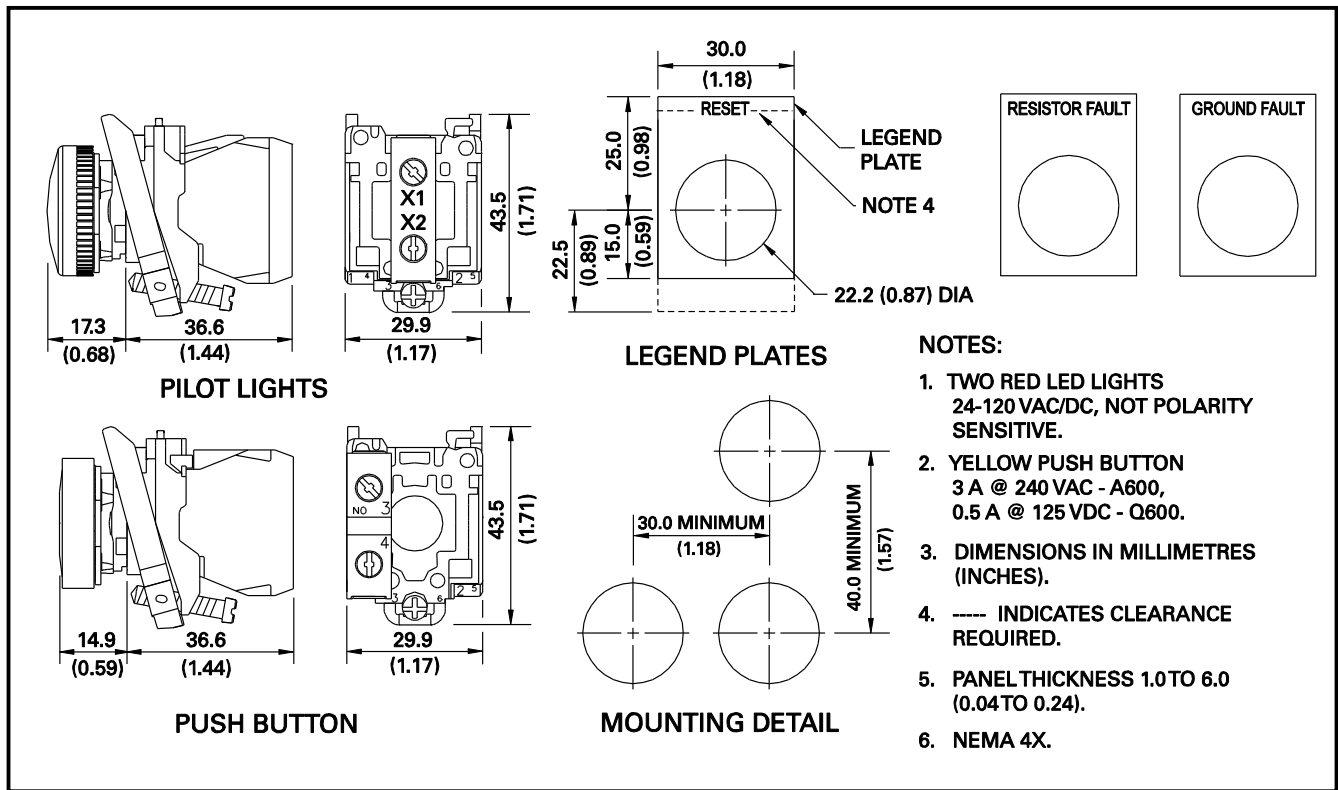

FIGURE 19. RK-332 Remote Indication and Reset.

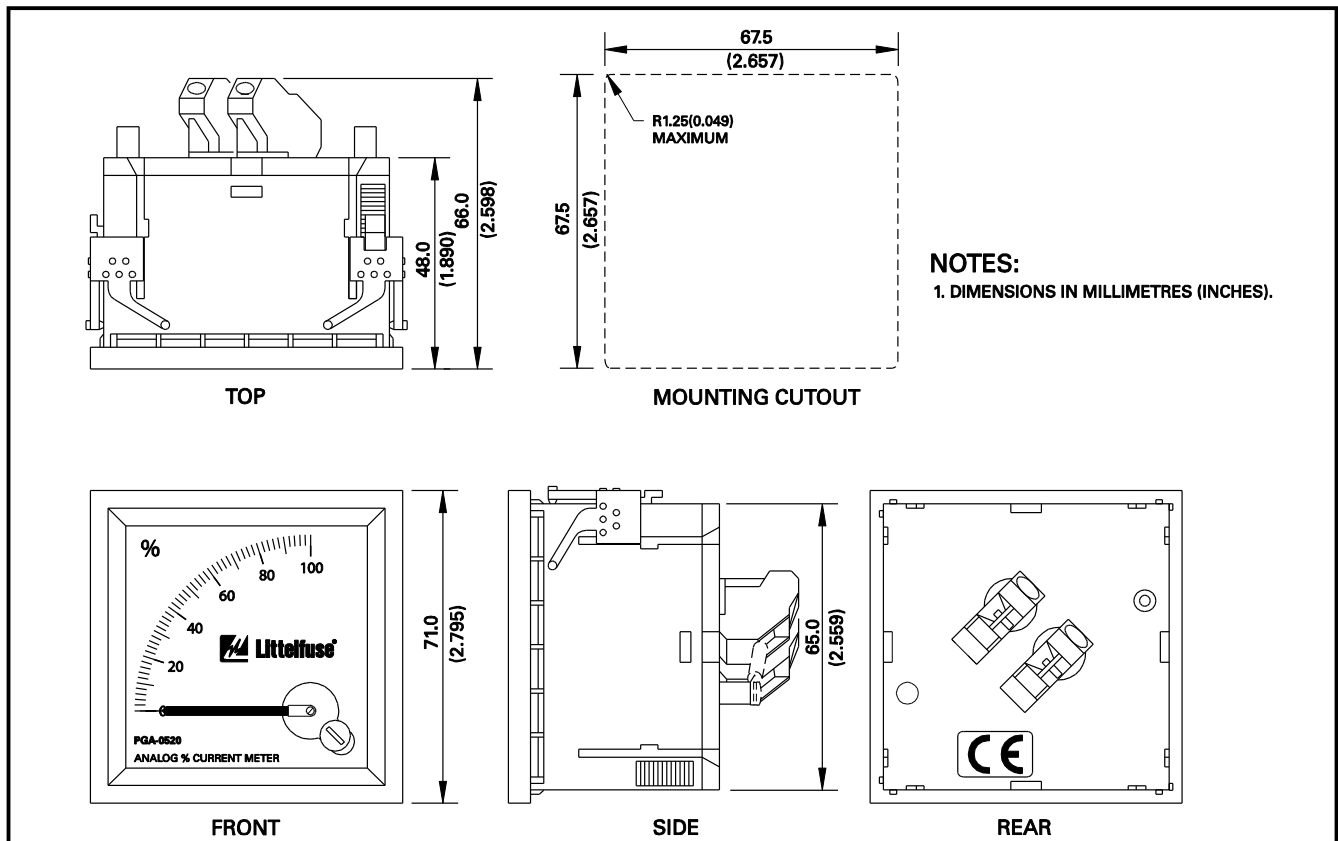

FIGURE 20. PGA-0520 Analog Percent Current Meter.

3.4 ISOLATED EARTH CONNECTION

Isolated earthing can prevent an earth potential rise (EPR) from being transferred to remote equipment. If the G terminals on the sensing resistor and the SE-330AU are connected to isolated earth, the SE-330AU will be exposed to the EPR. If the EPR is greater than the terminal-block rating, the SE-330AU must be isolated from station earth and precautions must be taken with the power supply and the trip contacts. See Technical Note RG-1 “NGR Monitoring with Isolated Ground Beds” at www.littelfuse.com/relayscontrols.

A configuration which allows an SE-330AU to be connected to station earth is shown in Fig. 21. The SE-330AU monitors the series combination of the NER and the two earthing points. This configuration is acceptable provided the series resistance of the NER and earth is within the NER calibration range and earth-resistance changes remain within the trip range. See Section 6.1.

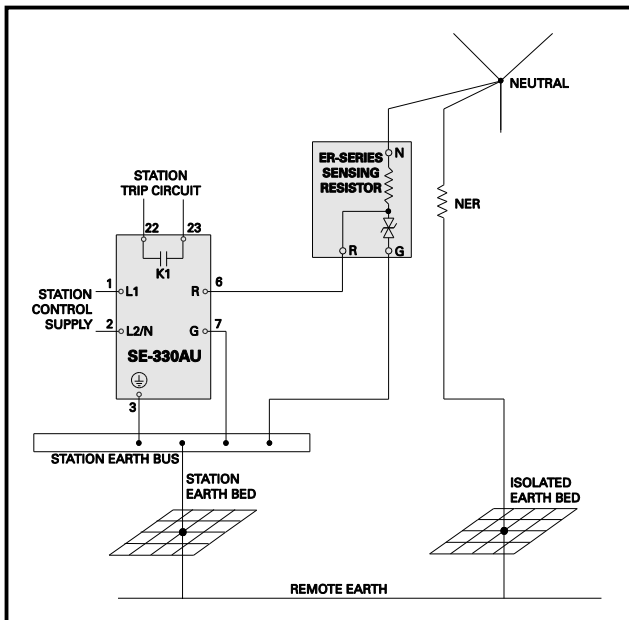

FIGURE 21. Simplified Isolated-Earth Connection.

4. DATA INTERFACES

4.1 SD CARD

The SE-330AU supports microSD™ data storage. The microSD™ card port is located on the front panel just below the USB port. The microSD™ card is used for long-term data logging of measured values and for firmware upgrades.

NOTE: SD card performance may vary by manufacturer, model, and with varying environmental conditions. The included microSD™ card has a temperature rating of -25 to 85°C (-13 to 140°F). For applications colder than -25°C (-13°F), use an Industrial-Grade microSD™ card.

NOTE: SD card usage is intended for use with the SE-330AU only. Do not store other data on the SD card – files may be automatically deleted.

4.1.1 DATALOGGING

When a microSD™ card is installed, the SE-330AU looks for a directory called “Datalogging”. If this directory exists, data logging will automatically start after the card is indexed (indexing may take several minutes depending on the size of the card and the number of files).

The log is updated every two seconds and it includes measured values, configuration parameters, and trip status. A new log file is created at the start of each day. If previous log files exist and the microSD™ card has less than 20 MB of free space, the oldest datalogging file will automatically be deleted before a new file is created.

The red DIAGNOSTIC LED may indicate a microSD™ card error. See Sections 2.8 and 5. Approximately 3 GB of data is generated per year of logging.

4.1.2 FIRMWARE UPGRADE

Firmware upgrades are performed using a microSD™ card in conjunction with configuration switch S8. See Section 2.1.4.5. The SE-Flash software is not required.

To upgrade the SE-330AU firmware, insert a microSD™ card containing the firmware upgrade file (.S19 format) in the root directory of the SD card and set switch S8 to UPGRADE within 30 seconds of card installation. If S8 is switched to UPGRADE after 30 seconds, the upgrade process will not occur. If the microSD™ card is inserted after S8 is switched to UPGRADE, switch S8 to RUN and then back to UPGRADE. The SE-330AU evaluates firmware upgrade files found in the root directory of the microSD™ card and uses the first valid file.

Ensure that the DIAGNOSTIC LED is off before beginning the firmware upgrade process.

The red DIAGNOSTIC LED blinks rapidly while the firmware upgrade is running and the SE-330AU may reset multiple times during the upgrade process. Do not remove the SD card or power off the SE-330AU until the DIAGNOSTIC LED has stopped blinking rapidly for at least 30 seconds. If the upgrade is not successful, the DIAGNOSTIC LED will indicate an SD Upgrade Error.

See Section 5. Set switch S8 back to RUN for normal operation. If a firmware upgrade fails, the existing firmware is not overwritten.

A record of the upgrade can be found in “upgrade_log_<SN>.txt” on the microSD™ card. This file is updated each time an upgrade is performed.

NOTE: The maximum microSD™ card storage capacity is 32 GB for SE-330AU hardware revision 16 and higher. The maximum microSD™ card storage capacity is 4 GB for SE-330AU hardware revision 15 and lower.

4.2 USB INTERFACE

Use the SE-MON330 software (version 3.8 or newer) to access set-points, measured values, and trip records through the mini B USB interface located on the front panel. The following data can be viewed:

- Front-panel and configuration-switch settings
- Neutral voltage and neutral current
- Resistance change from the calibrated value
- Trip status
- Trip records, 100 date and time stamped
- Firmware version and serial number

The following values can be viewed and adjusted:

- Earth-fault trip setting (when front-panel EF Trip Level is set to MEM)
- K2 earth-fault relay output operating mode
- K3 resistor-fault relay output operating mode
- Clock settings
- Trip records can be cleared
- Remote calibration
- Resistor-fault trip time
- Resistor-fault trip level
- Geo-magnetic filter
- Critical and non-critical diagnostic codes

Ensure the real-time clock is set to the correct time prior to normal operation. Trip records and on-board datalogging information include date and time readings from the clock. Refer to the SE-MON330 software help file.

4.3 NETWORK COMMUNICATIONS

The optional communications interfaces include a single CAN port and dual Ethernet ports supporting cable, fiber⁽¹⁾, or both cable and fiber. Protocols include:

- DeviceNet over CAN (ordering option 1)
- EtherNet/IP over cable or fiber (ordering options 3, 4, and 5)
- Modbus TCP over cable or fiber (ordering options 3, 4, and 5)
- IEC 61850 over cable or fiber (ordering options 6, 7, and 8) – also includes Modbus TCP

Refer to the appropriate SE-330 communications-interface manual for details.

⁽¹⁾ Uses the plug-in style SC connector.

5. TROUBLESHOOTING

PROBLEM	DIAGNOSTIC LED FLASH CODE ⁽¹⁾	SOLUTION
POWER LED off.		Check if supply voltage is present on terminals 1 and 2. If present, an overvoltage may have caused the power supply to shutdown. Cycle supply voltage. If POWER LED remains off, return unit for repair.
POWER LED flashes.		A power-supply overload has occurred. Cycle supply voltage. If problem persists, consult Littelfuse Startco.
Calibration-Error Trip DIAGNOSTIC LED flash code	1 L - 1 S - 1 L	The total resistance of the NER and sensing-resistor circuit is outside the calibration range. Verify that switch S5 is set to match the resistance of the sensing resistor, check the resistance of the NER, and verify the sensing-resistor circuit. See Section 9.2 for sensing-resistor tests. Repeat the calibration procedure after the open or shorted condition has been corrected. Critical diagnostic code. EF LED ⁽²⁾ : No Change, RF LED ⁽²⁾ : ON, K1:Trip
Remote Trip DIAGNOSTIC LED flash code	1 L - 2 S - 1 L	The SE-330AU was tripped by a signal from network communications. Press RESET to clear the trip. Critical diagnostic code. EF LED ⁽²⁾ : ON, RF LED ⁽²⁾ : ON, K1:Trip
CT-Detection-Error Trip DIAGNOSTIC LED flash code	1 L - 3 S - 1 L	The CT connection to the SE-330AU is open. Correct the problem and press RESET. Critical diagnostic code.
A/D-Converter-Error Trip DIAGNOSTIC LED flash code	1 L - 4 S - 1 L	An A/D-converter error was detected. Press RESET to clear the trip. If the problem persists, consult Littelfuse Startco. Critical diagnostic code. EF LED ⁽²⁾ : No Change, RF LED ⁽²⁾ : ON, K1:Trip
SD Card DIAGNOSTIC LED flash code	1 L - 5 S - 1 L	SD Card is full or a write error occurred. Delete files or use a different microSD™ card. Non-critical diagnostic code. EF LED ⁽²⁾ : No Change, RF LED ⁽²⁾ : No Change, K1:No Change If this diagnostic was caused during an attempt to upgrade the firmware, follow this alternate process: - remove supply from SE-330AU - insert a microSD card containing the firmware upgrade file in the root directory of the SD card - power on the SE-330AU - set switch S8 to UPGRADE within 30 seconds - the upgrade should continue as described in Section 4.1.2
Watchdog Trip DIAGNOSTIC LED flash code	1 L - 6 S - 1 L	A watchdog trip results in a processor reset. During reset, UNIT HEALTHY relay K4 will be de-energized. After a reset, UNIT HEALTHY relay K4 will be energized. Press RESET to clear the trip. If the problem persists, consult Littelfuse Startco. Critical diagnostic code. EF LED ⁽²⁾ : ON, RF LED ⁽²⁾ : ON, K1:Trip
CPU Trip DIAGNOSTIC LED flash code	1 L - 7 S - 1 L	The CPU has detected a system fault. Press RESET to clear the trip. Critical diagnostic code. EF LED ⁽²⁾ : ON, RF LED ⁽²⁾ : ON, K1:Trip
Non-Volatile Memory Error Trip DIAGNOSTIC LED flash code	1 L - 8 S - 1 L	An error was detected in the Non-Volatile Memory. Press RESET to clear the trip. If the problem persists, consult Littelfuse Startco. Critical diagnostic code. EF LED ⁽²⁾ : ON, RF LED ⁽²⁾ : ON, K1:Trip
SD Upgrade Error DIAGNOSTIC LED flash code	1 L - 9 S - 1 L	An error occurred during the flash-memory upgrade procedure. Ensure that the firmware upgrade file is correct or use a different microSD™ card. Critical diagnostic code. EF LED ⁽²⁾ : No Change, RF LED ⁽²⁾ : No Change, K1:No Change

PROBLEM	DIAGNOSTIC LED FLASH CODE ⁽¹⁾	SOLUTION
USB Error Diagnostic LED Flash Code	1 L – 10 S – 1 L	A USB algorithm timeout has been detected. Remove and reconnect the USB cable and cycle supply voltage. If the problem persists contact Littelfuse Startco. Non-critical diagnostic code. EF LED ⁽²⁾ : No Change, RF LED ⁽²⁾ : No Change, K1:No Change
DIAGNOSTIC LED = Solid Red		SE-330AU processor failed to start. Cycle supply. If problem persists, consult Littelfuse Startco. K1: De-energized.
Pressing RESET does not clear trips.		Trip condition is still present. Locate and correct. The RESET button is disabled if remote-reset terminals 15 and 16 are connected. Replace shorted remote-reset switch or issue Reset command from the communications network.
UNIT HEALTHY relay K4 momentarily changes state.		Occurs when processor is reset.
No analog-output current.		The output at terminals 19 and 20 requires a voltage source. See Fig. 2 for analog-output connections. See Section 9.3 for the analog-output tests.

NOTES:

⁽¹⁾ *L = long pause, S = short flash.

⁽²⁾ When LED is on, corresponding indication relay is energized when in the non-fail-safe mode or de-energized when in the fail-safe mode.

6. TECHNICAL SPECIFICATIONS

6.1 SE-330AU

Supply:

Option 0	30 VA, 120 to 240 Vac (+10, -45%), 50/60 Hz; 20 W, 110 to 250 Vdc (+10, -25%)
Option 2	20 W, 48 Vdc (+50, -25%); 35 VA, 48 Vac (+10, -45%), 50/60 Hz

Power-Up Time.....3 s at 120 Vac

AC Measurements.....Discrete Fourier
Transform. 16 samples
per cycle, 50 or 60 Hz

Resistor-Fault Circuit:

Neutral-To-Earth Voltage Trip Levels⁽¹⁾:

ER-600VC or ER-5KV	20; 60; 100; 130; 170; 200; 340; 800; 1,200; 1,700; 2,000 Vac
ER-15KV to ER-35KV	100; 300; 500; 650; 850; 1,000; 1,700; 4,000; 6,000; 8,500; 10,000 Vac
Accuracy	10% of setting
3 dB Frequency Response:	
S6 = 50 Hz	25 to 85 Hz
S6 = 60 Hz	30 to 90 Hz

NER Calibration Range:

ER-600VC, ER-5KV, or ER-5WP	0 to 2 kΩ
ER-15KV to ER-35KV	0 to 10 kΩ

Trip Resistance, V_N = 0:

ER-600VC, ER-5KV, or ER-5WP:	
Range ⁽⁵⁾	250 to 750-Ω change ± 200 Ω
Default	± 500-Ω change
ER-15KV to ER-35KV:	
Range ⁽⁵⁾	1.25 to 3.75-kΩ change ± 1 kΩ
Default	± 2.5-kΩ change

Neutral-to-Earth DC-Voltage Rejection:

ER-600VC, ER-5KV, or ER-5WP	25 Vdc
ER-15KV to ER-35KV	125 Vdc

Trip Time.....12 to 60 s ± 1 s
Trip Hold-Off Level.....5% of CT-Primary Rating
Trip Mode.....Latching/Non-Latching

Earth-Fault Circuit:

Trip Level⁽²⁾:

EFCT-x	0.125, 0.25, 0.30, 0.40, 0.50, 1, 2, 3, 4, 5 A
--------------	---

SE-CS30-x.....0.75, 1.5, 1.8, 2.4, 3.0, 6.0,
12.0, 18.0, 24.0, 30.0 A

Trip Time.....0.10, 0.12, 0.14, 0.16, 0.18,
0.20, 0.25, 0.30, 0.35, 0.40,
0.50 s

Trip-Level Accuracy+0, -20% of setting

Trip-Time Accuracy.....+0, -20% of setting

3 dB Frequency Response:

S6 = 50 Hz	25 to 85 Hz
S6 = 60 Hz	30 to 90 Hz

CT-Input Burden:

EFCT Input.....	11 Ω
CS30 Input.....	10 Ω

CT Detection Threshold.....15 Ω

Thermal Withstand:

Continuous	10 x CT Rating
1-Second	25 x CT Rating

Measurement Range25 x CT-Primary Rating

Trip Mode.....Latching/Non-Latching

Trip Relay K1 Contacts:

Configuration	N.O. (Form A)
Operating Mode	Fail-Safe
CSA/UL Contact Ratings	8 A resistive 250 Vac, 5 A resistive 30 Vdc

Supplemental Contact Ratings:

Make/Carry 0.2 s.....30 A

Break:

dc.....	75 W resistive, 35 W inductive (L/R = 0.04 s)
ac.....	2,000 VA resistive, 1,500 VA inductive (PF = 0.4)

Subject to maximums of 8 A at 250 Vac, 5 A resistive at 30 Vdc, and 0.4 A resistive at 250 Vdc.

EF (K2) and RF (K3) Relay Contacts:

Configuration	N.O. and N.C. (Form C)
Operating Mode ⁽⁵⁾	Non-Fail-Safe or Fail-Safe
CSA/UL Contact Ratings	8 A resistive 250 Vac, 8 A resistive 30 Vdc

Supplemental Contact Ratings:

Make/Carry 0.2s.....20 A

Break:

dc.....	50 W resistive, 25 W inductive (L/R = 0.04 s)
ac.....	2,000 VA resistive, 1,500 VA inductive (PF = 0.4)

Subject to maximums of 8 A at 250 Vac, 8 A resistive at 30 Vdc, and 0.4 A resistive at 150 Vdc.

Unit Healthy Output K4 (Option 0):

Configuration	N.O. (Form A)
Operating Mode	Closed when Healthy

Ratings 100 mA, 250 V (ac or dc)
Closed Resistance 30 to 50 Ω

Unit Healthy Output K4 (Option 1):
Configuration N.C. (Form B)
Operating Mode Open when Healthy
Ratings 100 mA, 250 V (ac or dc)
Closed Resistance 25 to 50 Ω

Auto-reset time 2.8 s maximum

4-20-mA Analog Output:
Type Self Powered and
Loop Powered
Range 4 to 22 mA
Loop Voltage 8 to 36 Vdc
Load 500 Ω (maximum with 24-
Vdc supply)
Isolation 120 Vac
Parameter NER Current, 20 mA=
CT Primary Current

USB Communications:
Baud Rate 12 Mbit/s
Protocol USB Device
Connector Mini B

SD Memory Card:
Type Standard Grade
Form Factor microSD™⁽³⁾ and
microSDHC™⁽³⁾
Format FAT32
Capacity:
SE-330AU Hardware
Revision 16 and higher 512 MB to 32 GB
SE-330AU Hardware
Revision 15 and lower 512 MB to 4 GB

Operating Temperature:
Standard Grade
(Included) -25 to 85°C (-13 to 140°F)
Industrial Grade -40 to 85°C (-40 to 140°F)

Terminal-Block Ratings 10 A, 300 Vac, 2.5 mm²

PWB Conformal Coating MIL-1-46058 qualified,
UL QMJU2 recognized

Mounting Configurations Panel Mount and
Optional Surface Mount

Dimensions:
Height 213 mm (8.4")
Width 99 mm (3.9")
Depth 132 mm (5.2")

Shipping Weight 2.0 kg (4.4 lb)

Environment:
Operating Temperature -40 to 60°C (-40 to 140°F)
Storage Temperature -55 to 80°C (-67 to 176°F)
Humidity 85% Non-Condensing
IP Rating IP30
Surge Withstand ANSI/IEEE C37.90.1-1989
(Oscillatory and Fast
Transient)

EMC Tests:
Verification tested in accordance with IEC 60255-26:2013.

Radiated and Conducted
Emissions CISPR 11:2009,
CISPR 22:2008,
EN 55022:2010
Class A

Current Harmonics and
Voltage Fluctuations IEC 61000-3-2
and IEC 61000-3-3
Class A

Electrostatic Discharge IEC 61000-4-2
± 6 kV contact discharge
(direct and indirect)
± 8 kV air discharge

Radiated RF Immunity IEC 61000-4-3
10 V/m, 80-1,000 MHz,
80% AM (1 kHz)
10 V/m, 1.0 to 2.7 GHz,
80% AM (1 kHz)

Fast Transient IEC 61000-4-4
Zone B
± 2 kV (power supply port),
± 1 kV (all other ports)

Surge Immunity IEC 61000-4-5
Zone B
± 1 kV differential mode
± 2 kV common mode

Conducted RF Immunity IEC 61000-4-6
10 V, 0.15-80 MHz,
80% AM (1 kHz)

Magnetic Field
Immunity IEC 61000-4-8
50 Hz and 60 Hz
30 A/m and 300 A/m

Power Frequency⁽⁴⁾ IEC 61000-4-16
Zone A: differential mode
100 Vrms
Zone A: common mode
300 Vrms

1 MHz BurstIEC 61000-4-18
± 1 kV differential mode
(line-to-line)
± 2.5 kV common mode

Voltage InterruptionIEC 61000-4-11,
IEC 61000-4-29
0% for 10, 20, 30,
50 ms (dc)
0% for 0.5, 1, 2.5,
5 cycles (60 Hz)
IEC 61000-4-17
Level 4, 15% of rated dc
value

CertificationAustralia



CE, European Union



To: Australia, Regulatory Compliance Mark (RCM)
CE Low Voltage Directive
IEC 61010-1:2010 (3rd Edition) + AMD 1:2016
FCC CFR47, Part 15, Subpart B,
Class A – Unintentional Radiators

ComplianceAS/NZS 2081.3:2002

NOTES:

- (1) See sensing resistor specifications for applicable voltage limits.
- (2) When set to MEM, the range is 2 to 100% of CT Primary Rating.
- (3) microSD™ and microSDHC™ are trademarks of SD-3C, LLC.
- (4) Remote-reset wiring is limited to 10 m (32').
- (5) This value can only be modified using SE-MON330 software. See Section 4.2.

6.2 SENSING RESISTORS

Environment:

Operating Temperature-40 to 60°C (-40 to 140°F)
Storage Temperature-55 to 80°C (-67 to 176°F)

ER-600VC:

Maximum Voltage600 Vac
Maximum Current30 mA
Resistance20 kΩ
Thermal:
420 VacContinuous
600 Vac6 minutes on,
60 minutes off
Shipping Weight300 g (0.7 lb)

ER-5KV:

Maximum Voltage2,500 Vac
Maximum Current125 mA
Resistance20 kΩ
ThermalContinuous
Torque:
Terminal N:
10-32 Insert5.6 N•m (50 lbf•in)
Others9.0 N•m (80 lbf•in)
Shipping Weight5.0 kg (11 lb)

ER-5WP:

Maximum Voltage2,500 Vac
Maximum Current125 mA
Resistance20 kΩ
ThermalContinuous
Torque:
Terminal N:
10-32 Insert5.6 N•m (50 lbf•in)
Others9.0 N•m (80 lbf•in)
Shipping Weight5.0 kg (11 lb)

ER-15KV:

Maximum Voltage8,400 Vac
Maximum Current84 mA
Resistance100 kΩ
Thermal:
8,400 Vac1 minute on,
120 minutes off
1,900 VacContinuous
Torque (Terminal N)9.0 N•m (80 lbf•in)
Shipping Weight5.0 kg (11 lb)

ER-25KV:

Maximum Voltage14,400 Vac
Maximum Current144 mA
Resistance100 kΩ
Thermal:
14,400 Vac1 minute on,
120 minutes off
2,500 VacContinuous
Torque (Terminal N)9.0 N•m (80 lbf•in)
Shipping Weight20 kg (44 lb)

ER-35KV:

Maximum Voltage22,000 Vac
Maximum Current220 mA
Resistance100 kΩ
Thermal:
22,000 Vac1 minute on,
120 minutes off
3,000 VacContinuous
Torque (Terminal N)9.0 N•m (80 lbf•in)
Shipping Weight40 kg (88 lb)

CertificationCSA, Canada and USA



UL Listed



Grounding Equipment,
Neutral Grounding Devices
4GG4 E346992

Australia



CE, European Union



6.3 CURRENT SENSORS

Environment:

Operating Temperature-40 to 60°C (-40 to 140°F)
Storage Temperature-55 to 80°C (-67 to 176°F)

EFCT-1:

Current Ratio5:0.05 A
Insulation600-V Class
Window Diameter82 mm (3.2")
Shipping Weight.....0.9 kg (2.0 lb)
CertificationsCSA, UL, CE
ComplianceRoHS, IEC 60044-1

EFCT-26:

Current Ratio5:0.05 A
Insulation600-V Class
Window Diameter26 mm (1.0")
Shipping Weight.....0.45 kg (1.0 lb)
CertificationsCSA, UL, CE
ComplianceRoHS, IEC 60044-1

SE-CS30-26:

Current Ratio30:0.05 A
Insulation600-V Class
Window Diameter26 mm (1.0")
Shipping Weight.....0.45 kg (1.0 lb)
CertificationsCSA, UL, CE
ComplianceRoHS, IEC 60044-1

SE-CS30-70:

Current Ratio30:0.05 A
Insulation600-V Class
Window Diameter70 mm (2.7")
Shipping Weight.....1.2 kg (2.5 lb)
CertificationsCSA, UL, CE
ComplianceRoHS, IEC 60044-1

7. ORDERING INFORMATION

SE-330AU-



K4 Contact:
0 N.O. UNIT HEALTHY Contact
1 N.C. UNIT HEALTHY Contact

Options:
0 No Options

Network Communications:⁽¹⁾
0 None

1 DeviceNet™
3 Ethernet (Dual RJ45)⁽²⁾
4 Ethernet (SC Fiber & RJ45)⁽²⁾
5 Ethernet (Dual SC Fiber)⁽²⁾
6 IEC 61850 (Dual RJ45)⁽³⁾
7 IEC 61850 (SC Fiber & RJ45)⁽³⁾
8 IEC 61850 (Dual SC Fiber)⁽³⁾

Supply:
0 Universal ac/dc Supply
2 48 Vdc Supply

NOTE: Please refer to the SE-330 Product Change Notice (PCN) document for updated ordering information and new revision details, available at www.littelfuse.com/se-330au.

NOTE: The SE-330-SMA Surface Mount Adapter is available as an accessory only.

Sensing Resistors:

ER-600VC For system voltages up to 1 kVac
ER-5KV For system voltages up to 5 kVac
ER-5WP For system voltages up to 5 kVac, weather protected
ER-15KV For system voltages up to 15 kVac
ER-25KV For system voltages up to 25 kVac
ER-35KV For system voltages up to 35 kVac

Current Sensors:

EFCT-1 Current Sensor, 5-A-primary rating, 82 mm (3.2") window, 6 m (19.5') of 22 AWG (3.3 mm²) shielded cable included
EFCT-26 Current Sensor, 5-A-primary rating, 26 mm (1.0") window, 6m (19.5') of 22 AWG (3.3 mm²) shielded cable included
SE-CS30-26 Current Sensor, 30-A-primary rating, 26 mm (1.0") window
SE-CS30-70 Current Sensor, 30-A-primary rating, 70 mm (2.7") window

Accessories:

RK-332	Remote Indication and Reset, includes two 120-V pilot lights, a reset push button, and legend plates
SE-IP65CVR-G.....	Hinged transparent cover, IP65
SE-MRE-600.....	Moisture-resistant enclosure for ER-600VC
PGA-0520.....	Percent Analog Meter
SE-330-SMA.....	Surface Mount Adapter
AC300-MEM-00.....	Industrial-Grade microSD™ Card

Software: ⁽⁴⁾

SE-MON330 Software	SE-330AU Data-Display Program for PC, version 3.5 or newer
NER Monitor	
Set-Point Assistant	Setting Guide

NOTES:

- ⁽¹⁾ Profibus models only available on legacy SE-330AU.
- ⁽²⁾ Includes Modbus TCP and Ethernet/IP protocols.
- ⁽³⁾ Includes IEC 61850 and Modbus TCP protocols.
- ⁽⁴⁾ Available at www.littelfuse.com/relayscontrols.

8. WARRANTY

The SE-330AU Neutral-Earthing-Resistor Monitor is warranted to be free from defects in material and workmanship for a period of five years from the date of purchase.

Littelfuse Startco will (at Littelfuse Startco's option) repair, replace, or refund the original purchase price of an SE-330AU that is determined by Littelfuse Startco to be defective if it is returned to the factory, freight prepaid, within the warranty period. This warranty does not apply to repairs required as a result of misuse, negligence, an accident, improper installation, tampering, or insufficient care. Littelfuse Startco does not warrant products repaired or modified by non-Littelfuse Startco personnel.

9. TEST PROCEDURES

NOTE: Ensure the real-time clock is set. See Section 4.2.

9.1 RESISTOR-FAULT TESTS

Perform tests with system de-energized and supply voltage applied to the SE-330AU.

9.1.1 CALIBRATION AND OPEN TEST

Test Equipment: 20-k Ω and 100-k Ω , 1/4-watt, 1% calibration resistors (calibration resistors are supplied with SE-330AU).

Procedure:

- Remove connections to terminals 6 and 7.
- Connect the 20-k Ω resistor to terminals 6 and 7.
- Set switch S5 to the 20-k Ω position.
- Perform calibration as per Section 2.2.
- The CALIBRATED LED should be on.
- Press RESET.
- Remove the 20-k Ω resistor and wait for the resistor-fault trip time.

PASS: The SE-330AU should trip on resistor fault.

- Connect the 100-k Ω resistor to terminals 6 and 7.
- Set switch S5 to the 100-k Ω position.
- Perform calibration as per Section 2.2.
- The CALIBRATED LED should be on.
- Press RESET.
- Remove the 100-k Ω resistor and wait for the resistor-fault trip time.

PASS: The SE-330AU should trip on resistor fault.

NOTE: Resistor-fault-trip reset can take up to one second.

9.1.2 VOLTAGE TEST

Test Equipment: 0 to 120 Vac voltage source, multimeter, and ER sensing resistor.

NOTE: Use an isolation transformer if the test-voltage source does not provide dc continuity for the SE-330AU resistance-measuring circuit.

NOTE: Applying the test voltage to the R and G terminals will damage the SE-330AU and the ER sensing resistor. The V_N TRIP LEVEL is the trip voltage at terminal N, not terminal R.

Procedure:

- Connect the ER sensing resistor connection to the SE-330AU and calibrate the SE-330AU.
- Disconnect the wire from sensing-resistor terminal N.
- Set the voltage source to 0 V.
- Connect the voltage source between sensing resistor N and G terminals.
- Set the V_N TRIP LEVEL (VAC) to 20.
- Press RESET.

- The RESISTOR FAULT TRIP LED should be off.
- Increase the test voltage to 25 Vac for 20-k Ω sensors or 120 Vac for 100-k Ω sensors and wait the resistor-fault trip time.
- **PASS:** The SE-330AU should trip on RESISTOR FAULT. A time-delayed earth-fault trip follows the resistor-fault trip if neutral voltage persists after the resistor fault.

9.2 SENSING-RESISTOR TEST

Test Equipment: Multimeter.

Procedure:

- Disconnect the sensing resistor.
- Measure the resistance between sensing-resistor terminals R and N.
PASS: Resistance should be between 19.6 and 20.4 k Ω for 20-k Ω sensing resistors. Resistance should be between 98 and 102 k Ω for 100-k Ω sensing resistors.
- Measure the resistance between sensing-resistor terminals R and G in both directions.
PASS: Resistance should be greater than 10 M Ω in both directions.

9.3 ANALOG-OUTPUT TEST

Test Equipment: Multimeter with a mA_{dc} scale.

Procedure:

- Connect the 4–20-mA output as a self-powered output as shown in Fig. 3. Measure the current from terminal 20 to terminal 21.
PASS: With no CT current, the analog output should be 4 mA.
- Output is linear to 20 mA. Output is 20 mA when CT-primary current is equal to the CT-primary rating.

**APPENDIX A
SE-330AU REVISION HISTORY**

MANUAL RELEASE DATE	MANUAL REVISION	HARDWARE REVISION (REVISION NUMBER ON PRODUCT LABEL)	FIRMWARE REVISION
October 18, 2017	4-I-101817	17	2.60
December 7, 2016	4-H-120716	16	2.55
September 21, 2016	4-G-092116		2.54
June 30, 2016	4-F-063016		2.53
September 15, 2015	4-E-091515	15	2.52
June 22, 2015	4-D-062215		2.50
May 20, 2015	4-C-052015		2.40
March 3, 2015	4-B-030315		2.31
July 8, 2014	4-A-070814	14	2.31

MANUAL REVISION HISTORY

REVISION 4-I-101817

SECTION 2

New features described in Section 2.8.

SECTION 3

Updated installation instructions.

SECTION 4

SD Card note added.

SECTION 5

Troubleshooting information added.

SECTION 7

Ordering information updated.

REVISION 4-H-120716

APPENDIX A

Revision history updated.

REVISION 4-G-092116

SECTION 4

Updated firmware upgrade instructions.

APPENDIX

Revision history updated.

REVISION 4-F-063016

SECTION 4

Section 4.1.2 updated.

SECTION 6

microSD™ storage capacity increased to 32 GB.

RCM certification added.

REVISION 4-E-091515

SECTION 4

Section 4.1.2 updated.

SECTION 5

SD card diagnostic troubleshooting updated.

REVISION 4-D-062215

SECTION 2

Section 2.1.6 added.

SECTION 4

SD Card approximate yearly data logging usage updated.

SE-MON330 software version updated.

SECTION 6

Resistor-fault trip level ranges added.

REVISION 4-C-052015

SECTION 4

SD Card storage capacity updated.

SECTION 6

SD Card storage capacity specification updated.

REVISION 4-B-030315

SECTION 2

Sections 2.1.5 and 2.1.6 added.

SECTION 4

Section 4.2 new features added.

SECTION 6

Resistor-fault circuit trip time updated.

REVISION 4-A-070814

SECTION 1

Faceplate updated.

New features added.

SECTION 2

Communications options updated.

Configuration switches updated.

Indication relays explanation added.

Non-volatile-memory error added.

SECTION 3

Connection drawing updated

SECTION 4

Section changed to Data Interfaces.

Updated with microSD™ and USB interfaces.

Upgrade procedure added.

SECTION 5

Non-volatile-memory error added.

Switch S8 Diagnostic LED error removed.

SECTION 6

Earth-Fault Circuit Trip Level updated.

USB Communications specifications added.

SECTION 7

Ordering information updated.

HARDWARE REVISION HISTORY

HARDWARE REVISION 17

Enhanced transient protection added.

HARDWARE REVISION 16

microSD™ storage capacity increased to 32 GB.

HARDWARE REVISION 15

RTC circuit updated.

HARDWARE REVISION 14

Updated SE-330AU platform to include USB and microSD™ interfaces, programmable Trip Level (MEM) feature, and ability to add future options.

Real-time clock added.

FIRMWARE REVISION HISTORY

FIRMWARE REVISION 2.60

Added option to display only critical diagnostic codes with DIAGNOSTIC LED.

FIRMWARE REVISION 2.55

Corrected IEC 61850 Network watchdog resets.

FIRMWARE REVISION 2.54

NAND FLASH bit-error-correction update to prevent solid-red diagnostic LED error when bit errors are correctable.

Resistor-Fault Trip Level added to web interface.

Corrected MODBUS® TCP/IP write response byte count.

TCP Keep Alive network setting no longer resets to 5s after power cycle.

FIRMWARE REVISION 2.53

Fixed NAND FLASH bit error correction code to prevent solid-red diagnostic error.

FIRMWARE REVISION 2.52

Improved compatibility with Internet Explorer™ web browser.

FIRMWARE REVISION 2.50

Added support for adjustable resistor-fault trip level.

Web page functionality re-enabled for Ethernet options.

FIRMWARE REVISION 2.40

Added support for geo-magnetic filter.

Added support for 12 to 60 s resistor-fault trip time.

Improved log file descriptions.

IEC 61850 GOOSE network input support now always enabled.

Improved compatibility for Modbus TCP.

Web page disabled for Ethernet options. This will be enabled in a future firmware release.

IP setting changes for Ethernet options now require power cycle to take effect.

FIRMWARE REVISION 2.31

Updated firmware to include USB and microSD™ interfaces, datalogging, and firmware update via microSD™.

K2 and K3 indication relays can be configured for fail-safe or non-fail-safe operation.

Event records increased to 100 with date and time stamping.

Remote calibration feature added.

SD Card and USB diagnostic events do not cause a trip.

This page intentionally left blank.