

#18-24 TERMINAL SHOWN

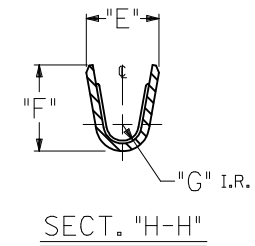

**NOTES:**

1. MATERIAL: PHOS. BRONZE
2. FINISH:
  - 2 = SELECTIVE GOLD PLATE .000030/(0.00076) MIN., AND SELECTIVE MATTE TIN .000100/(0.00254) OVER .000050/(0.00127) MIN. NICKEL OVERALL.
  - 3 = SELECTIVE GOLD PLATE .000015/(0.00038) MIN., AND SELECTIVE MATTE TIN .000080/(0.00203) OVER .000050/(0.00127) MIN. NICKEL OVERALL.
  - 4 = SELECTIVE GOLD PLATE .000050/(0.00127) MIN., AND SELECTIVE MATTE TIN .000100/(0.00254) OVER .000050/(0.00127) MIN. NICKEL OVERALL.
3. PRODUCT SPECIFICATION: SEE PSX-44485-0001.
4. PACKAGING SPECIFICATION: PK-44485-001 FOR CHAIN TERMINALS  
PK-5556-003 FOR LOOSE TERMINALS
5. MATES WITH 5558, 5566 AND 5569 SERIES CONNECTORS.
6. TERMINAL FOR USE WITH 5557, 30067, 42474, 44516, SERIES HOUSINGS.
- △ THE NUMBER OF SERRATIONS TO BE ONE FOR WIRE RANGE #22-28
8. WHEN TERMINALS ARE INSTALLED IN THE HOUSING THE WIRES ARE TO BE DRESSED IN SUCH A MANNER TO ALLOW THE TERMINALS TO FLOAT FREELY IN THE POCKET.
9. THIS TERMINAL IS DESIGNED FOR SINGLE WIRE CRIMPING
10. PART CONFORMS TO CLASS "B" REQUIREMENTS OF COSMETIC SPECIFICATION PS-45499-002
- △△ TEXT ON PART IS FOR REFERENCE ONLY. TEXT AND TEXT LOCATION MAY VARY DEPENDING ON PART NUMBER AND/OR TOOL.

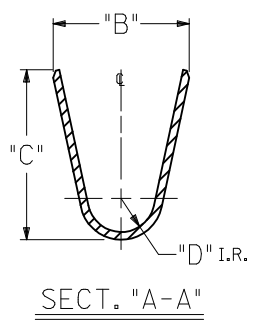
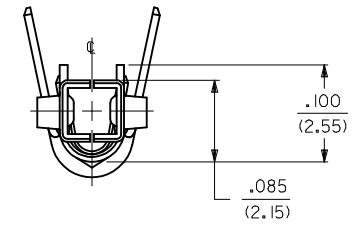

ADD TOL TO DIM D EC NO: UCP2017-2202 DRWING: BAPPELDORN 2017/07/26 CHKD: APPR: FSMITH 2017/09/29 REV: C5	QUALITY SYMBOLS	GENERAL TOLERANCES (UNLESS SPECIFIED)	DIMENSION STYLE IN/MM	SCALE 10:1	DESIGN UNITS METRIC	THIRD ANGLE PROJECTION
	▽=0	4 PLACES ± --- ± ---	mm INCH	DRAWN BY GEP	DATE 08/08/94	TITLE HIGH CYCL'G TERM FEM CRIMP, MINI-FIT JR. BLANK-PLATE-FORM
	▽=0	3 PLACES ± --- ± .010		CHECKED BY RJF	DATE 08/08/94	<b>molex</b> DOCUMENT NO. SD-44485-**** SHEET NO. 1 OF 2
	▽=0	2 PLACES ± 0.25 ± .014		APPROVED BY FSMITH	DATE 2013/04/26	
		1 PLACE ± 0.36 ± ---	ANGULAR ±1/2°	MATERIAL NO.	THIS DRAWING CONTAINS INFORMATION THAT IS PROPRIETARY TO MOLEX INCORPORATED AND SHOULD NOT BE USED WITHOUT WRITTEN PERMISSION	
	0 PLACE ± --- ± ---	DRAFT WHERE APPLICABLE MUST REMAIN WITHIN DIMENSIONS	SIZE C	SEE CHART		

ITEM NO.	WIRE GAGE	DIM. "B"	DIM. "C"	DIM. "D"	DIM. "E"	DIM. "F"	DIM. "G"
44485-1211	18-24 GA.	.142±.012	.177±.016	.035±.016	.075±.012	.091±.016	.020
44485-1212		(3.60±0.30)	(4.50±0.40)	(0.90±0.40)	(1.90±0.30)	(2.30±0.40)	(0.50)
X 44485-2211	22-28 GA.	.091±.012	.091±.016	.024±.016	.071±.012	.065±.016	.016
X 44485-2212		(2.30±0.30)	(2.30±0.40)	(0.60±0.40)	(1.80±0.30)	(1.65±0.40)	(0.40)
X 44485-3211	16 GA.	.142±.012	.177±.016	.035±.016	.091±.012	.106±.016	.024
X 44485-3212		(3.60±0.30)	(4.50±0.40)	(0.90±0.40)	(2.30±0.30)	(2.70±0.40)	(0.60)
X 44485-5211	28-30 GA.	.091±.012	.091±.016	.024±.016	.050±.010	.044±.010	.010
X 44485-5212		(2.30±0.30)	(2.30±0.40)	(.60 ±0.40)	(1.27±0.25)	(1.12±0.25)	(0.25)
X 44485-1311	18-24 GA.	.142±.012	.177±.016	.035±.016	.075±.012	.091±.016	.020
X 44485-1312		(3.60±0.30)	(4.50±0.40)	(0.90±0.40)	(1.90±0.30)	(2.30±0.40)	(0.50)
X 44485-2311	22-28 GA.	.091±.012	.091±.016	.024±.016	.071±.012	.065±.016	.016
X 44485-2312		(2.30±0.30)	(2.30±0.40)	(0.60±0.40)	(1.80±0.30)	(1.65±0.40)	(0.40)
X 44485-3311	16 GA.	.142±.012	.177±.016	.035±.016	.091±.012	.106±.016	.024
X 44485-3312		(3.60±0.30)	(4.50±0.40)	(0.90±0.40)	(2.30±0.30)	(2.70±0.40)	(0.60)
X 44485-5311	28-30 GA.	.091±.012	.091±.016	.024±.016	.050±.010	.044±.010	.010
X 44485-5312		(2.30±0.30)	(2.30±0.40)	(.60 ±0.40)	(1.27±0.25)	(1.12±0.25)	(0.25)
X 44485-1411	18-24 GA.	.142±.012	.177±.016	.035±.016	.075±.012	.091±.016	.020
X 44485-1412		(3.60±0.30)	(4.50±0.40)	(0.90±0.40)	(1.90±0.30)	(2.30±0.40)	(0.50)
X 44485-2411	22-28 GA.	.091±.012	.091±.016	.024±.016	.071±.012	.065±.016	.016
X 44485-2412		(2.30±0.30)	(2.30±0.40)	(0.60±0.40)	(1.80±0.30)	(1.65±0.40)	(0.40)
X 44485-3411	16 GA.	.142±.012	.177±.016	.035±.016	.091±.012	.106±.016	.024
X 44485-3412		(3.60±0.30)	(4.50±0.40)	(0.90±0.40)	(2.30±0.30)	(2.70±0.40)	(0.60)
X 44485-5411	28-30 GA.	.091±.012	.091±.016	.024±.016	.050±.010	.044±.010	.010
X 44485-5412		(2.30±0.30)	(2.30±0.40)	(.60 ±0.40)	(1.27±0.25)	(1.12±0.25)	(0.25)

**LEGEND:**

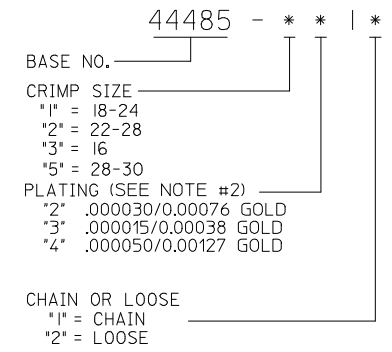

<b>SEE SHEET 1</b> EC NO: UCP2017-2202 DRW: BAPPELDORN 2017/07/26 CHKD: APPR: FSMITH 2017/09/29	QUALITY SYMBOLS	GENERAL TOLERANCES (UNLESS SPECIFIED)	DIMENSION STYLE	SCALE	DESIGN UNITS	THIRD ANGLE PROJECTION
	▽=0	mm INCH	IN/MM	1:1	METRIC	
	▽=0	4 PLACES ± --- ± ---	DRAWN BY DATE	TITLE		
	▽=0	3 PLACES ± --- ±.010	CHECKED BY DATE	HIGH CYCL'G TERM FEM		
	▽=0	2 PLACES ± 0.25 ±.014	RJF 08/08/94	CRIMP, MINI-FIT JR.		
	1 PLACE ± 0.36 ± ---	APPROVED BY DATE	BLANK-PLATE-FORM			
	0 PLACE ± --- ± ---	FSMITH 2013/04/26	<b>molex</b>			
	ANGULAR ±1/2°	MATERIAL NO.	DOCUMENT NO.		SHEET NO.	
	DRAFT WHERE APPLICABLE MUST REMAIN WITHIN DIMENSIONS	SEE CHART	SD-44485-****		2 OF 2	
		SIZE	THIS DRAWING CONTAINS INFORMATION THAT IS PROPRIETARY TO MOLEX INCORPORATED AND SHOULD NOT BE USED WITHOUT WRITTEN PERMISSION			

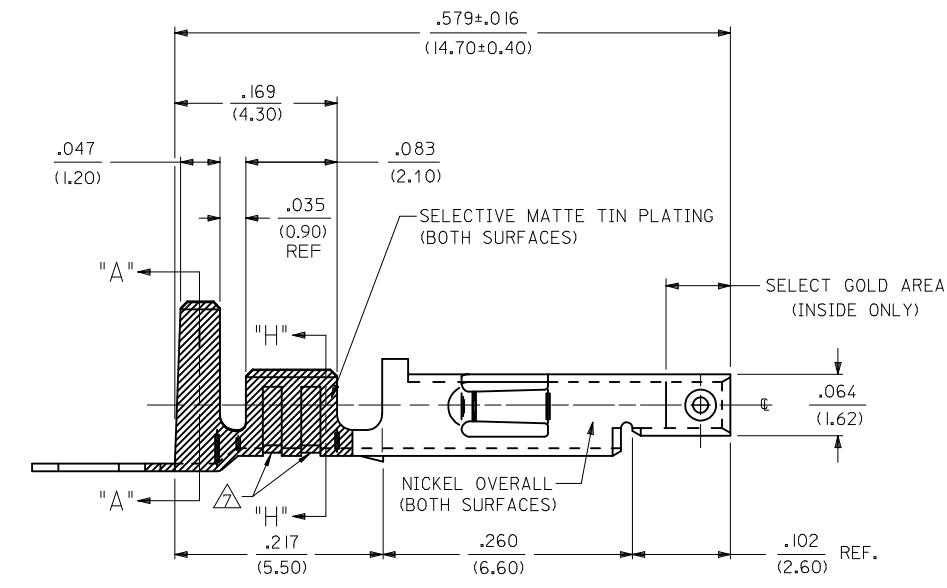
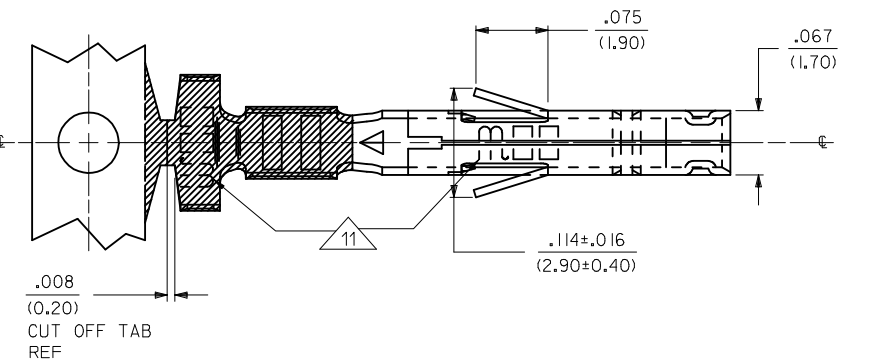

#18-24 TERMINAL SHOWN

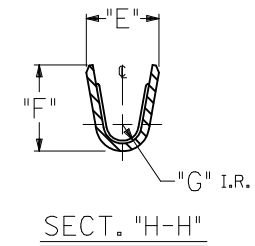
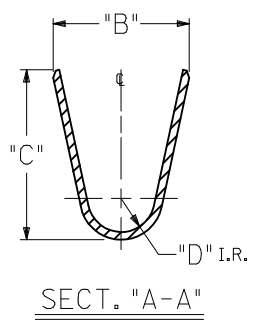

**NOTES:**

1. MATERIAL: PHOS. BRONZE
2. FINISH:
  - 2 = SELECTIVE GOLD PLATE .000030/(0.00076) MIN., AND SELECTIVE MATTE TIN .000100/(0.00254) OVER .000050/(0.00127) MIN. NICKEL OVERALL.
  - 3 = SELECTIVE GOLD PLATE .000015/(0.00038) MIN., AND SELECTIVE MATTE TIN .000080/(0.00203) OVER .000050/(0.00127) MIN. NICKEL OVERALL.
  - 4 = SELECTIVE GOLD PLATE .000050/(0.00127) MIN., AND SELECTIVE MATTE TIN .000100/(0.00254) OVER .000050/(0.00127) MIN. NICKEL OVERALL.
3. PRODUCT SPECIFICATION: SEE PSX-44485-0001.
4. PACKAGING SPECIFICATION: PK-44485-001 FOR CHAIN TERMINALS  
PK-5556-003 FOR LOOSE TERMINALS
5. MATES WITH 5558, 5566 AND 5569 SERIES CONNECTORS.
6. TERMINAL FOR USE WITH 5557, 30067, 42474, 44516, SERIES HOUSINGS.
- △ THE NUMBER OF SERRATIONS TO BE ONE FOR WIRE RANGE #22-28
8. WHEN TERMINALS ARE INSTALLED IN THE HOUSING THE WIRES ARE TO BE DRESSED IN SUCH A MANNER TO ALLOW THE TERMINALS TO FLOAT FREELY IN THE POCKET.
9. THIS TERMINAL IS DESIGNED FOR SINGLE WIRE CRIMPING
10. PART CONFORMS TO CLASS "B" REQUIREMENTS OF COSMETIC SPECIFICATION PS-45499-002
- △△ TEXT ON PART IS FOR REFERENCE ONLY. TEXT AND TEXT LOCATION MAY VARY DEPENDING ON PART NUMBER AND/OR TOOL.

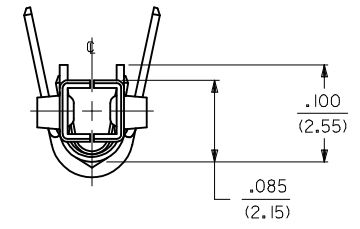

ADD TOL TO DIM D EC NO: UCP2017-2202 DRWING: BAPPELDORN 2017/07/26 CHKD: APPR: FSMITH 2017/09/29	QUALITY SYMBOLS	GENERAL TOLERANCES (UNLESS SPECIFIED)	DIMENSION STYLE	SCALE	DESIGN UNITS	THIRD ANGLE PROJECTION
	▽=0	mm INCH	IN/MM	10:1	METRIC	
	▽=0	4 PLACES ± --- ± ---	DRAWN BY DATE	TITLE		
	▽=0	3 PLACES ± --- ± .010	CHECKED BY DATE	HIGH CYCL'G TERM FEM		
	▽=0	2 PLACES ± 0.25 ± .014	APPROVED BY DATE	CRIMP, MINI-FIT JR.		
		1 PLACE ± 0.36 ± ---	FSMITH 2013/04/26	BLANK-PLATE-FORM		
		0 PLACE ± --- ± ---		molex		
		ANGULAR ±1/2°	MATERIAL NO.	DOCUMENT NO.	SHEET NO.	
		DRAFT WHERE APPLICABLE MUST REMAIN WITHIN DIMENSIONS	SEE CHART	SD-44485-****	1 OF 2	
			THIS DRAWING CONTAINS INFORMATION THAT IS PROPRIETARY TO MOLEX INCORPORATED AND SHOULD NOT BE USED WITHOUT WRITTEN PERMISSION			

ITEM NO.	WIRE GAGE	DIM. "B"	DIM. "C"	DIM. "D"	DIM. "E"	DIM. "F"	DIM. "G"
44485-1211	18-24 GA.	.142±.012	.177±.016	.035±.016	.075±.012	.091±.016	.020
44485-1212		(3.60±0.30)	(4.50±0.40)	(0.90±0.40)	(1.90±0.30)	(2.30±0.40)	(0.50)
X 44485-2211	22-28 GA.	.091±.012	.091±.016	.024±.016	.071±.012	.065±.016	.016
X 44485-2212		(2.30±0.30)	(2.30±0.40)	(0.60±0.40)	(1.80±0.30)	(1.65±0.40)	(0.40)
X 44485-3211	16 GA.	.142±.012	.177±.016	.035±.016	.091±.012	.106±.016	.024
X 44485-3212		(3.60±0.30)	(4.50±0.40)	(0.90±0.40)	(2.30±0.30)	(2.70±0.40)	(0.60)
X 44485-5211	28-30 GA.	.091±.012	.091±.016	.024±.016	.050±.010	.044±.010	.010
X 44485-5212		(2.30±0.30)	(2.30±0.40)	(.60 ±0.40)	(1.27±0.25)	(1.12±0.25)	(0.25)
X 44485-1311	18-24 GA.	.142±.012	.177±.016	.035±.016	.075±.012	.091±.016	.020
X 44485-1312		(3.60±0.30)	(4.50±0.40)	(0.90±0.40)	(1.90±0.30)	(2.30±0.40)	(0.50)
X 44485-2311	22-28 GA.	.091±.012	.091±.016	.024±.016	.071±.012	.065±.016	.016
X 44485-2312		(2.30±0.30)	(2.30±0.40)	(0.60±0.40)	(1.80±0.30)	(1.65±0.40)	(0.40)
X 44485-3311	16 GA.	.142±.012	.177±.016	.035±.016	.091±.012	.106±.016	.024
X 44485-3312		(3.60±0.30)	(4.50±0.40)	(0.90±0.40)	(2.30±0.30)	(2.70±0.40)	(0.60)
X 44485-5311	28-30 GA.	.091±.012	.091±.016	.024±.016	.050±.010	.044±.010	.010
X 44485-5312		(2.30±0.30)	(2.30±0.40)	(.60 ±0.40)	(1.27±0.25)	(1.12±0.25)	(0.25)
X 44485-1411	18-24 GA.	.142±.012	.177±.016	.035±.016	.075±.012	.091±.016	.020
X 44485-1412		(3.60±0.30)	(4.50±0.40)	(0.90±0.40)	(1.90±0.30)	(2.30±0.40)	(0.50)
X 44485-2411	22-28 GA.	.091±.012	.091±.016	.024±.016	.071±.012	.065±.016	.016
X 44485-2412		(2.30±0.30)	(2.30±0.40)	(0.60±0.40)	(1.80±0.30)	(1.65±0.40)	(0.40)
X 44485-3411	16 GA.	.142±.012	.177±.016	.035±.016	.091±.012	.106±.016	.024
X 44485-3412		(3.60±0.30)	(4.50±0.40)	(0.90±0.40)	(2.30±0.30)	(2.70±0.40)	(0.60)
X 44485-5411	28-30 GA.	.091±.012	.091±.016	.024±.016	.050±.010	.044±.010	.010
X 44485-5412		(2.30±0.30)	(2.30±0.40)	(.60 ±0.40)	(1.27±0.25)	(1.12±0.25)	(0.25)

**LEGEND:**

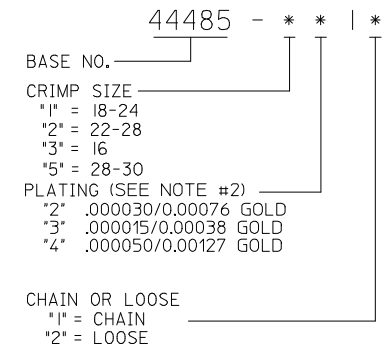

<b>SEE SHEET 1</b> EC NO: UCP2017-2202 DRW: BAPPELDORN 2017/07/26 CHKD: _____ APPR: FSMITH 2017/09/29	QUALITY SYMBOLS	GENERAL TOLERANCES (UNLESS SPECIFIED)	DIMENSION STYLE	SCALE	DESIGN UNITS	THIRD ANGLE PROJECTION
	▽=0	mm INCH	IN/MM	1:1	METRIC	☉
	▽=0	4 PLACES ± --- ± ---	DRAWN BY DATE	TITLE		
	▽=0	3 PLACES ± --- ±.010	GEP 08/08/94	HIGH CYCL'G TERM FEM		
	▽=0	2 PLACES ± 0.25 ±.014	CHECKED BY DATE	CRIMP, MINI-FIT JR.		
	1 PLACE ± 0.36 ± ---	RJF 08/08/94	BLANK-PLATE-FORM			
	0 PLACE ± --- ± ---	APPROVED BY DATE	<b>molex</b>			
		FSMITH 2013/04/26	MATERIAL NO.	DOCUMENT NO.	SHEET NO.	
			SEE CHART	SD-44485-****	2 OF 2	
			THIS DRAWING CONTAINS INFORMATION THAT IS PROPRIETARY TO MOLEX INCORPORATED AND SHOULD NOT BE USED WITHOUT WRITTEN PERMISSION			