

Description

The AL1698 is a high performance, high power factor, high efficiency, and high current precision buck-boost and flyback dimmable LED driver for triac dimmable LED lamp applications. The AL1698 topology provides an accurate output current over wide line and load regulation. The wide switching frequency operates at Boundary Conduction Mode (BCM) to ease EMI/EMC design and testing, to meet the latest regulatory standards.

The AL1698 LED driver has a built-in high voltage JFET, which provides the system fast start-up time and enables users an easy and stable V_{CC} supply design. The AL1698 also integrates a 600V/2A high voltage MOSFET. It can cover 230V_{AC} triac dimmable applications with eliminating the external high voltage MOSFET and V_{CC} startup resistors, which will reduce the system BOM cost. The AL1698 has the built-in thermal fold-back protection trigger point to automatically reduce output current. Other protection features enhance LED lighting system's safety and reliability.

The AL1698 dimming curve is compliant with the NEMA SSL6 standard. The AL1698 applies to a wide range of dimmers, including leading edge and trailing edge dimmer, to achieve deep dimming down to 1%.

The AL1698 is available in SO-7 package.

Features

- Tight Current Sense Tolerance : $\pm 3\%$
- Low Operation Current : 310 μ A
- Single Winding Inductor
- Wide Range of Dimmer Compatibility
- Integration of 600V/2A MOSFET
- Integration of HV JFET
- NEMA SSL6 Dimming Curve Compliant
- Internal Protections
 - Under Voltage Lockout (UVLO)
 - Leading-Edge Blanking (LEB)
 - Cycle-By-Cycle Over Current Protection (OCP)
 - Output Open/Short Protection (OVP/OSP)
 - Thermal Foldback Protection (TFP)
 - Over Temperature Protection (OTP)
- SO-7 Package
- **Totally Lead-Free & Fully RoHS Compliant (Notes 1 & 2)**
- **Halogen and Antimony Free. "Green" Device (Note 3)**

Notes: 1. No purposely added lead. Fully EU Directive 2002/95/EC (RoHS), 2011/65/EU (RoHS 2) & 2015/863/EU (RoHS 3) compliant.
 2. See <https://www.diodes.com/quality/lead-free/> for more information about Diodes Incorporated's definitions of Halogen- and Antimony-free, "Green" and Lead-free.
 3. Halogen- and Antimony-free "Green" products are defined as those which contain <900ppm bromine, <900ppm chlorine (<1500ppm total Br + Cl) and <1000ppm antimony compounds.

Pin Assignments

(Top View)

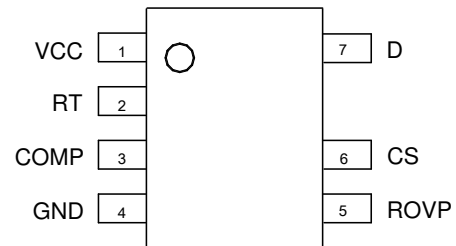

SO-7

Applications

- Mains Dimmable LED Lamps
- Offline LED Power Supply Driver

Typical Application Circuits

NEW PRODUCT

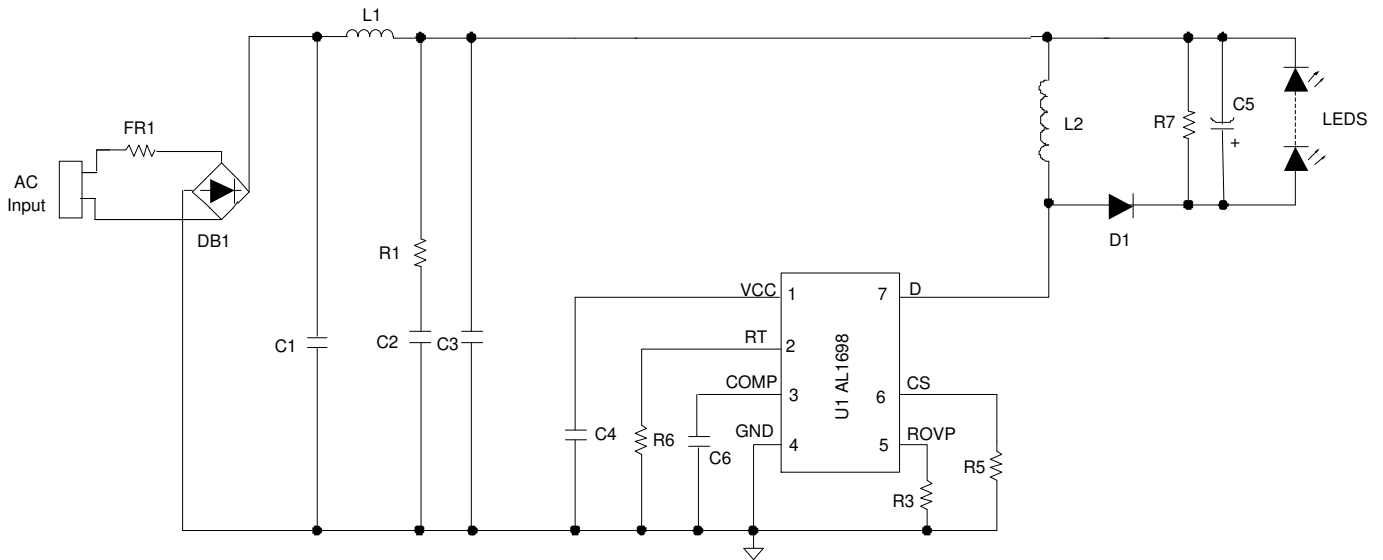

AL1698 Buck-Boost Application Circuit

Pin Descriptions

Pin Number	Pin Name	Function
1	VCC	Power Supply Voltage
2	RT	Connect a Resistor to Set the System's Maximum t_{ON}
3	COMP	Compensation for Current Control
4	GND	Ground
5	ROVP	Connect a Resistor to Set LED Open Protection Voltage
6	CS	Current Sensing
7	D	Drain of the Internal High Voltage MOSFET

Functional Block Diagram

NEW PRODUCT

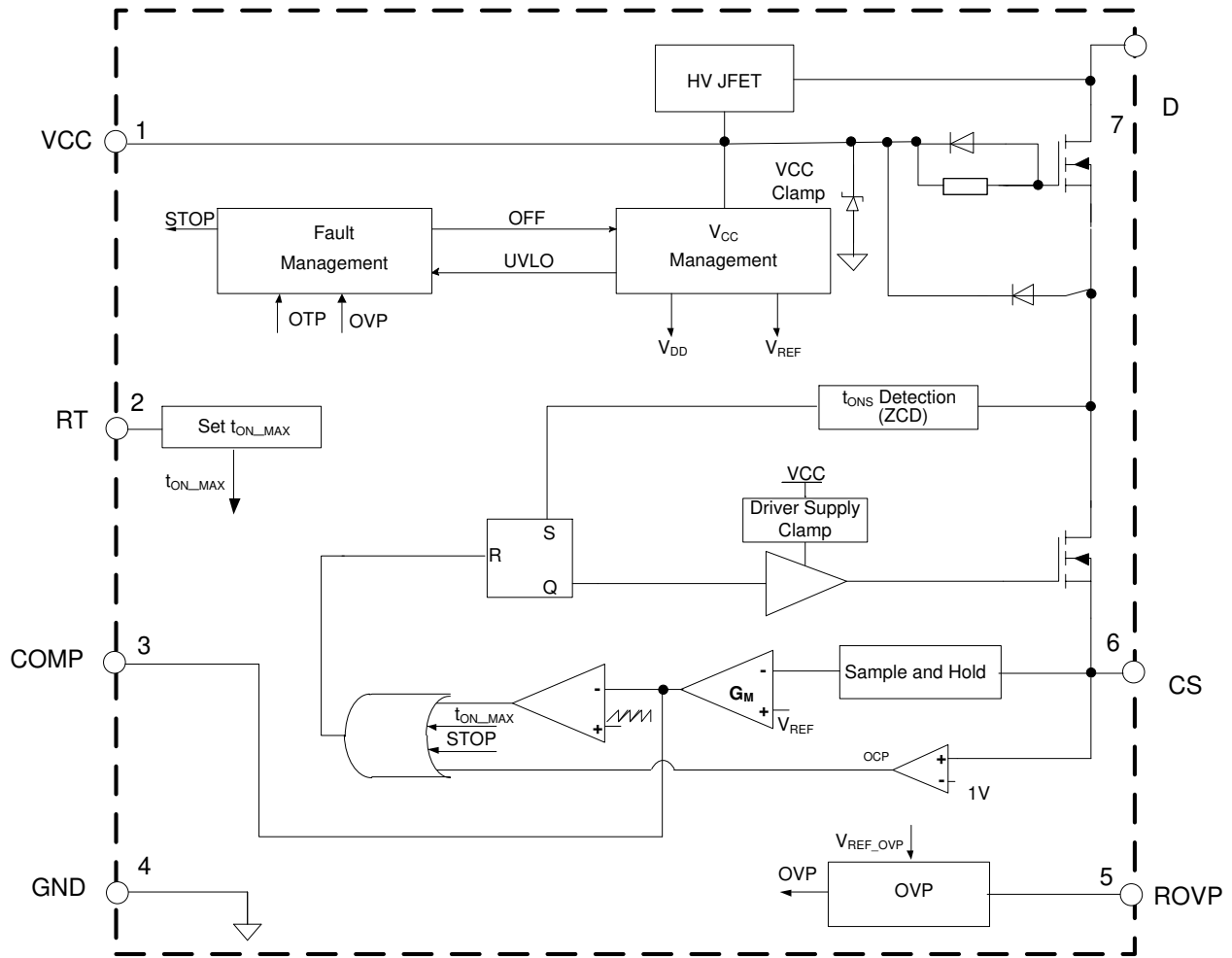

AL1698 Block Diagram

Absolute Maximum Ratings (@T_A = +25°C, unless otherwise specified.) (Note 4)

Symbol	Parameter	Rating	Unit
V _{CC}	Power Supply Voltage	18	V
V _D	Voltage on D Pin	600	V
I _{DS}	Continuous Drain Current T _C = +25°C	2	A
V _{CS}	Voltage on CS Pin	-0.3 to 7	V
V _{RT}	Voltage on RT Pin	-0.3 to 7	V
V _{ROVP}	Voltage on ROVP Pin	-0.3 to 7	V
T _J	Operating Junction Temperature	-40 to +150	°C
T _{STG}	Storage Temperature	-65 to +150	°C
T _{LEAD}	Lead Temperature (Soldering, 10s)	+260	°C
P _D	Power Dissipation (T _A = +50°C) (Note 5)	0.8	W
θ _{JA}	Thermal Resistance (Junction to Ambient) (Note 5)	115	°C/W
θ _{JC}	Thermal Resistance (Junction to Case) (Note 5)	19	°C/W
—	ESD (Human Body Model)	2,000	V
	ESD (Charged-Device Model)	1,000	V

- Notes:
- Stresses greater than those listed under "Absolute Maximum Ratings" can cause permanent damage to the device. These are stress ratings only, and functional operation of the device at these or any other conditions beyond those indicated under "Recommended Operating Conditions" is not implied. Exposure to "Absolute Maximum Ratings" for extended periods can affect device reliability. All voltages unless otherwise stated and measured with respect to GND.
 - Device mounted on 1"x1" FR-4 substrate PCB, 2oz copper, with minimum recommended pad layout.

Recommended Operating Conditions (@T_A = +25°C, unless otherwise specified.)

Symbol	Parameter	Min	Max	Unit
T _A	Ambient Temperature (Note 6)	-40	+105	°C
V _{CC}	Operating V _{CC} Voltage	7.3	V _{CC_CLAMP} (Min)	V

- Note:
- The device may operate normally at +125°C ambient temperature under the condition not trigger temperature protection.

Electrical Characteristics (@T_A = +25°C, unless otherwise specified.)

NEW PRODUCT

Symbol	Parameter	Condition	Min	Typ	Max	Unit
High Voltage Startup Current Source						
I _{HV}	High Voltage Supply Current	V _{CC} = 8.8V; V _D = 100V	7	10.5	—	mA
I _{LEAK}	Leakage Current of Drain	V _{CC} = 8.8V; V _D = 600V	—	5	—	μA
UVLO						
V _{TH(ST)}	Startup Voltage	—	7	8.8	10	V
V _{OPR(MIN)}	Minimum Operating Voltage	After Turn On	5.5	7.1	8.5	V
V _{CC_CLAMP}	V _{CC} Clamp Voltage	I _{CC} = 1mA	7.5	9.5	10.5	V
V _{CC_CHARGE}	V _{CC} UVLO	—	3.5	4.2	5.5	V
Standby Current						
I _{CC(OPR)}	Operating Current	Switching Frequency at 4kHz	—	310	—	μA
Source Driver						
R _{DS(ON)_LV}	Internal Low Voltage MOSFET On-State Resistance (Note 7)	—	—	1	—	Ω
High Voltage and Super-Junction MOSFET						
R _{DS(ON)_HV}	Drain-Source On-State Resistance	—	—	4	5.5	Ω
V _{DS}	Drain-Source Breakdown Voltage	(Note 9)	600	—	—	V
RT Pin						
V _{RT_REF}	Reference Voltage of RT Pin	—	0.45	0.5	0.54	V
Current Sense						
V _{CS_CLAMP}	Current Sense Clamp Voltage	—	0.9	1	1.1	V
V _{REF}	Internal Current Loop Control Reference	—	0.388	0.4	0.412	V
t _{ON_MIN}	Minimum t _{ON}	—	—	610	—	ns
t _{ON_MAX}	Maximum t _{ON}	R _T = 51kΩ, V _{COMP} = 4V	4.1	5.5	7.6	μs
t _{OFF_MIN}	Minimum t _{OFF} (Note 7)	—	—	4	—	μs
t _{OFF_MAX}	Maximum t _{OFF}	—	—	313	—	μs
ROVP Pin						
V _{ROVP_REF}	Reference Voltage of ROVP Pin	—	0.45	0.5	0.54	V
I _{ROVP}	ROVP Pin Current	ROVP Short to GND	—	110	—	μA
Error Amplifier						
G _M	G _M Trans-Conductance	—	—	25	—	μA/V
I _{SOURCE}	Amplifier Source Current	V _{CS} = 0V	—	10	—	μA
I _{SINK}	Amplifier Sink Current	V _{CS} = 1V	—	15	—	μA
Thermal Foldback and Over Temperature Protection (OTP)						
T _{FOLD}	Thermal Foldback (Note 7)	—	—	+150	—	°C
—	Thermal Shutdown (Notes 7 and 8)	—	—	+170	—	°C

Notes: 7. These parameters, although guaranteed by design, are not tested in production.
8. The device will latch off when OTP happens, recovered after power cycle and the device won't operate normally at this temperature.
9. The drain-source voltage is 80% of V_{DS} in the aging condition.

Performance Characteristics (Note 10)

NEW PRODUCT

Startup Voltage vs. Ambient Temperature

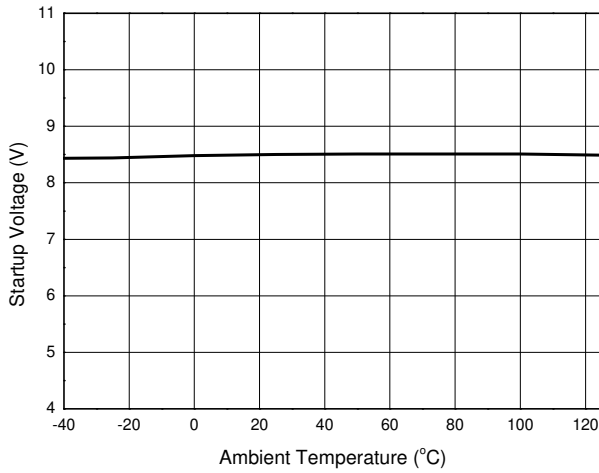

V_{CS_REF} vs. Ambient Temperature

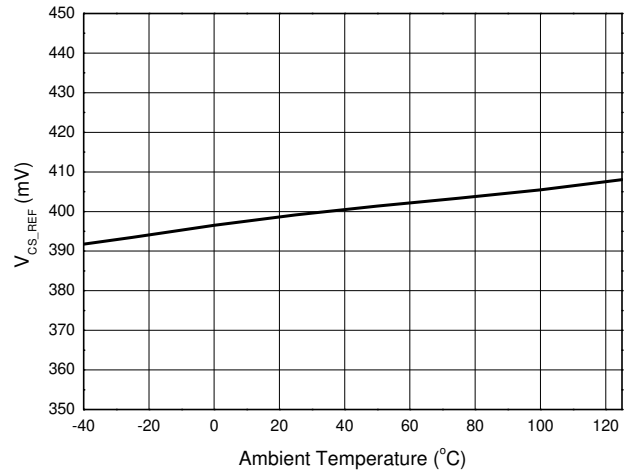

Supply Current vs. Ambient Temperature

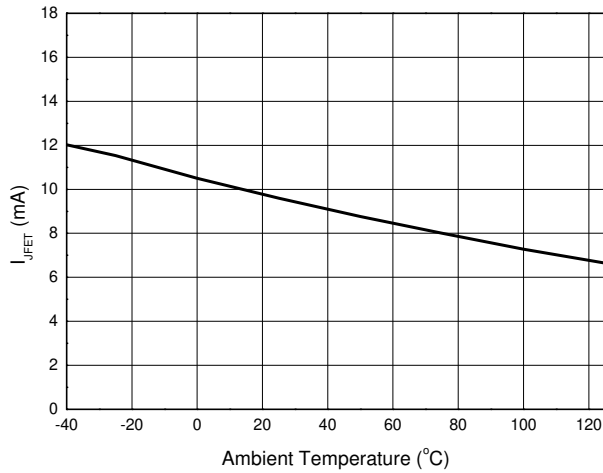

Operating Current vs. Ambient Temperature

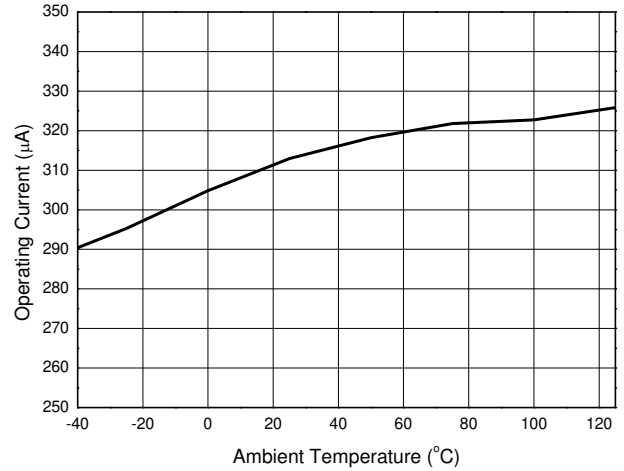

V_{RT_REF} vs. Ambient Temperature

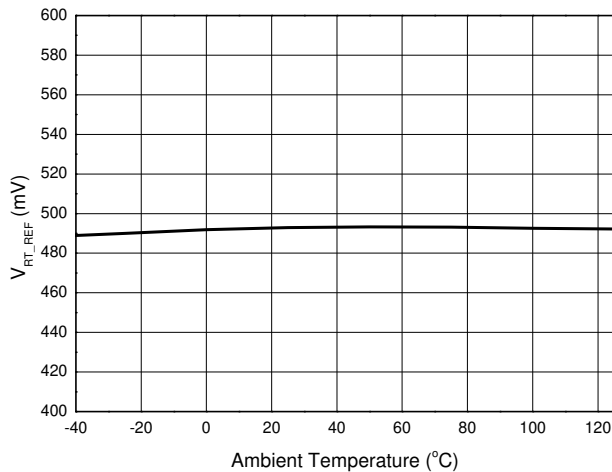

V_{ROVP_REF} vs. Ambient Temperature

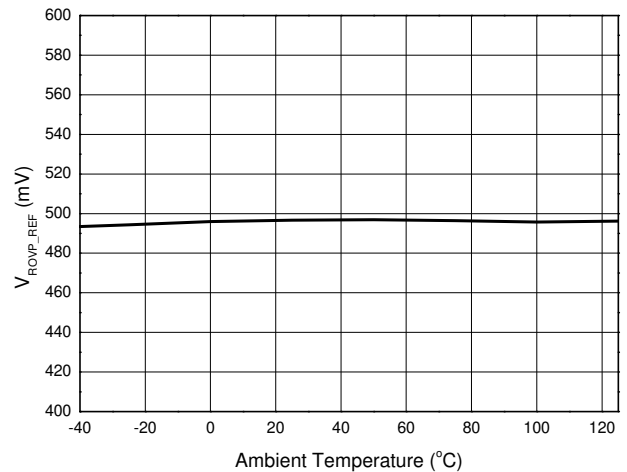

Note: 10. These electrical characteristics are tested under DC condition. The ambient temperature is equal to the junction temperature of the device.

Functional Description and Application Information

Operation

The AL1698 is a single stage, single winding, high efficiency, and high power factor dimmable LED driver for triac dimmable LED lamp applications. The AL1698 integrates a high voltage JFET and a 600V/2A high voltage MOSFET, and it can cover 230V_{AC} triac dimmable applications with eliminating external high voltage MOSFET and V_{CC} startup resistors.

The AL1698 adopts source-driver technique to decrease the system operating current. It uses a novel method to detect the t_{OFF} time which results in the removal for the need of an auxiliary winding. The AL1698 operates at Boundary Conduction Mode (BCM) which can ease EMI design and achieve high efficiency. High Power Factor (HPF) is achieved by using constant on-time mode. Coupled with a closed loop of constant current control, the AL1698 achieves good line and load regulation.

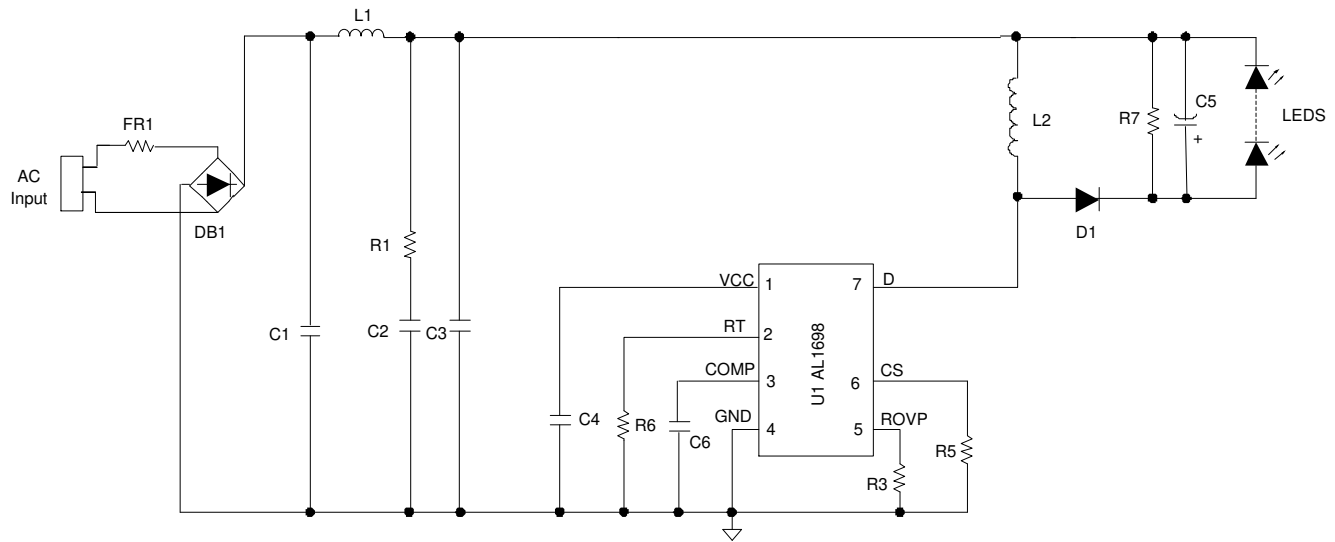

AL1698 Buck-Boost Application Circuit

Startup and Supply Voltage

Before startup, the V_{CC} capacitor C4 is charged by internal HV JFET. When the start-up voltage is reached, the AL1698 starts switching.

The AL1698 has an internal V_{CC} clamp voltage (typical 9.5V), which is limited by one internal active Zener diode.

When V_{CC} voltage drops below the V_{OPR(MIN)}, switching will be stopped. So the device can operate normally when the voltage on V_{CC} pin is between V_{OPR(MIN)} and V_{CC} clamp voltage.

Protections

Under Voltage Lockout (UVLO)

When the voltage on the V_{CC} pin drops below V_{CC_CHARGE}, the IC stops switch. The IC can restart when the voltage on V_{CC} exceeds the startup voltage (V_{TH(ST)}).

Leading-Edge Blanking (LEB)

To prevent false detection of the peak current of the inductor, a blanking time following switch-on is designed. When the internal switch turns on, a short current spike can occur because of the capacitive discharge of the voltages over the drain and source. It is disregarded during the LEB time (t_{ON_MIN}).

Functional Description and Application Information (continued)

Cycle-by-Cycle Over Current Protection (OCP)

The AL1698 has a built-in peak current detector. It is triggered when the voltage on CS pin reaches the peak level V_{CS_CLAMP} . The R5 is connected to the CS pin to sense the current of the inductor. The maximum peak current ($I_{PEAK(MAX)}$) of the inductor can be calculated as below:

$$I_{PEAK(MAX)} = \frac{V_{CS_CLAMP}}{R5} \dots\dots\dots(1)$$

The detection circuit is activated after the LEB time. When the detection circuit senses the CS voltage higher than 1V, the IC will turn off the switching to limit the output current. It automatically provides protection for the maximum LED current during operation. A propagation delay exists between over current detection and actual source-switch off, so the actual peak current is a little higher than the OCP level set by the R5.

Over Voltage Protection and Output Open Protection (OVP)

The AL1698 has output open voltage protection when the LED is open, which can prevent the output voltage from increasing to a very high value. This feature can help the system designer to select a smaller volume capacitor. The output voltage is set by the external resistor R3 shown in Figure 1.

When LED is open, the t_{OFF_OVP} time can be calculated as:

$$t_{OFF_OVP} = \frac{L2 \cdot V_{CS}}{V_{OVP} \cdot R5} \dots\dots\dots(2)$$

Where,

V_{OVP} is the output open voltage.

V_{CS} is the voltage on the CS pin when OVP happens.

The output voltage is set by R3, and R3 is calculated as:

$$R3 = \frac{V_{ROVP_REF} \cdot L2}{20 \cdot (2 \sim 2.25) \cdot C_{REF} \cdot V_{OVP} \cdot R5} \dots\dots\dots(3)$$

Where, V_{ROVP_REF} is the internal ROVP pin 0.5V's reference, C_{REF} is the internal 8.07pF capacitor.

Output-Short Protection (OSP)

When LED is shorted, the device cannot detect the t_{OFF} time, and the device controls the system operation at 4kHz low frequency.

Thermal Foldback Protection (TFP)

AL1698 has a Thermal Foldback Protection (TFP) function and adopts self-adaptive control method, which can prevent the system breaking down caused by high temperature. The overheating temperature is set at +150°C typical. When the junction temperature of the IC is higher than +150°C typical, the device will linearly decrease the internal reference voltage to decrease the output current. As a result of this feature, the device can control the system's output power at high ambient temperature, to control the system heat quality. This enhances the safety of the system at high temperature.

Functional Description and Application Information (continued)

Thermal foldback waveform is shown below.

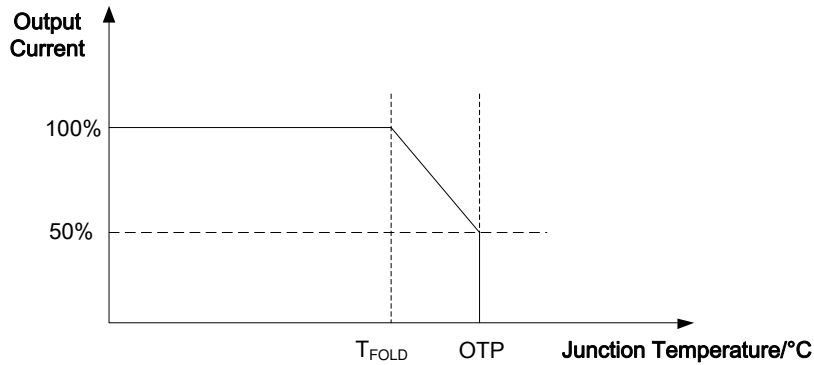

Figure 1. Thermal Foldback Waveform

Over-Temperature Protection (OTP)

The AL1698 has Over Temperature Protection (OTP) function. When the junction temperature reach to +170°C typical, the IC will trigger an over-temperature protection, which causes the device to shut down and latch up. Once OTP is triggered, the system needs to be resumed after the system’s AC source supply has been reset and powered up.

Design Parameters

Setting the Current Sense Resistor R5

The AL1698 adopts boundary conduction mode, the output current is calculated as below,

$$I_{O_MEAN} = \frac{1}{\pi} \cdot \int_0^{\pi} \frac{1}{2} \cdot I_{PEAK} \cdot \frac{t_{OFF}}{t_{ON} + t_{OFF} + t_{DELAY}} dt \dots\dots\dots (4)$$

Where,

- I_{PEAK} is the peak current of the inductance
- t_{ON} is the internal MOSFET on time
- t_{OFF} is the freewheel diode D1 conduction time
- t_{DELAY} is typical 0.4μs

The AL1698 is a closed loop constant current control with the relationship between output current and current sense voltage follows this equation

$$V_{REF} = \frac{1}{\pi} \cdot \int_0^{\pi} I_{PEAK} \cdot R5 \cdot \frac{t_{OFF}}{t_{ON} + t_{OFF} + t_{DELAY}} dt \dots\dots\dots (5)$$

Where,

- V_{REF} is the internal reference, typical 0.4V.
- R5 is the current sense resistor

So we can get the output current equation as below,

$$I_{O_MEAN} = \frac{1}{2} \cdot \frac{V_{REF}}{R5} \dots\dots\dots (6)$$

Inductance Selection (L2)

In buck-boost structure, the peak current of the inductance can be calculated as below

$$I_{PEAK} = \frac{\pi \cdot V_{REF}}{R5 \cdot \int_0^{\pi} \sin(\theta) \cdot \frac{\sqrt{2} \cdot V_{IN_RMS} \cdot \sin(\theta)}{\sqrt{2} \cdot V_{IN_RMS} \cdot \sin(\theta) + V_O} d\theta} \dots\dots\dots (7)$$

Functional Description and Application Information (continued)

Where,

- V_{IN_RMS} is the input voltage's RMS value
- V_O is the system output voltage

The AL1698 controls the system operating at boundary conduction mode which results in its operating frequency not being constant. To set the minimum switching frequency f_{MIN} at the crest of the minimum AC input.

$$L2 = \frac{\sqrt{2}V_{IN_RMS} \cdot V_O}{I_{PEAK} \cdot (\sqrt{2}V_{IN_RMS} + V_O) \cdot f_{MIN}} \dots\dots\dots (8)$$

According to the Faraday's Law, the winding number of the inductance can be calculated by:

$$N_{L2} = \frac{L2 \cdot I_{PEAK}}{A_e \cdot B_m} \dots\dots\dots (9)$$

Where,

- A_e is the core effective area.
- B_m is the maximum magnetic flux density.

t_{ON_MAX} Setting

In order to get a good dimmer compatibility and a good dimming depth, the device sets a t_{ON_MAX} by one external resistor R_T (R6). And the t_{ON_MAX} time has the below equation:

$$t_{ON_MAX} = \frac{3.3 \cdot C_{REF}}{\frac{V_{RT_REF}}{10 \cdot R6} + 0.5\mu A} \dots\dots\dots (10)$$

Where

- V_{RT_REF} is the internal RT pin 0.5V's reference.
- C_{REF} is the internal 1.5pF capacitor.

Dimming Control

The AL1698 is a closed loop control device; the dimming function is realized by t_{ON_MAX} limited when dimmer is connected in. When the dimmer is at the largest conduction angle, the device still has the adjustability to control the output current constant before COMP voltage is adjusted to the maximum 4V, so for most of the dimmer, the output current is almost the same with the no dimmer condition at the largest conduction angle. If the conduction angle is decreased, the COMP pin voltage will continue to increase quickly till to the maximum level (typical 4V), the device will output t_{ON_MAX} to limit system's output current. The t_{ON_MAX} is set by RT pin connected with one resistor, so the dimming depth can be adjusted by RT resistor (R6).

Before the AL1698 enters t_{ON_MAX} mode, it keeps the output current constant the same as no dimmer condition. When enter t_{ON_MAX} mode, we can get the following equation:

$$I_{PEAK_DIM} = \frac{V_{IN_RMS} \cdot Sin(\theta) \cdot t_{ON_MAX}}{L2} \dots\dots\dots (11)$$

From the buck-boost output current equation, we can get the output current when dimming:

$$I_o(\theta) = \begin{cases} \frac{1}{2} \cdot \frac{V_{REF}}{R5} & \text{if } t_{ON} < t_{ON_MAX} \\ \frac{1}{\pi} \int_0^\alpha \frac{1}{2} \cdot I_{PEAK_DIM} \cdot \frac{\sqrt{2}V_{IN_RMS} \cdot Sin(\theta)}{\sqrt{2}V_{IN_RMS} \cdot Sin(\theta) + V_O} d\theta & \text{else} \end{cases} \dots\dots\dots (12)$$

Where,

- α is the dimmer conduction angle.

Functional Description and Application Information (continued)

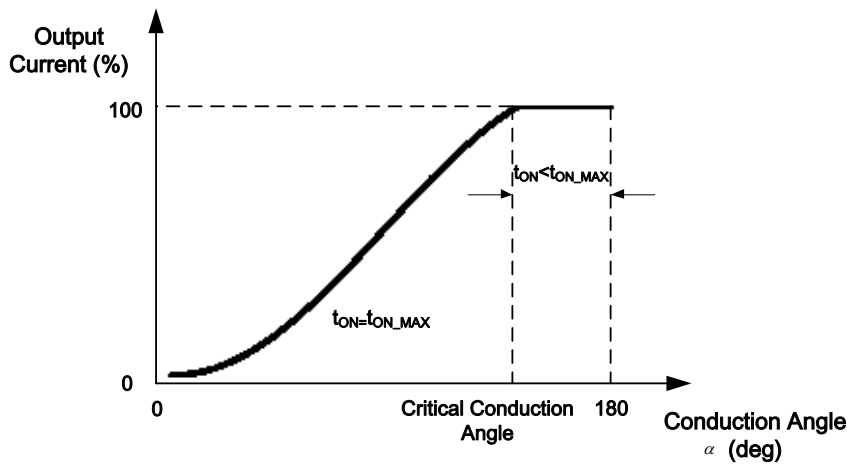

Figure 2. Dimming Curve

Dimmer Compatibility

Passive Bleeder Design

The passive bleeder is designed to supply latching and holding current to eliminate dimmer misfire and flicker.

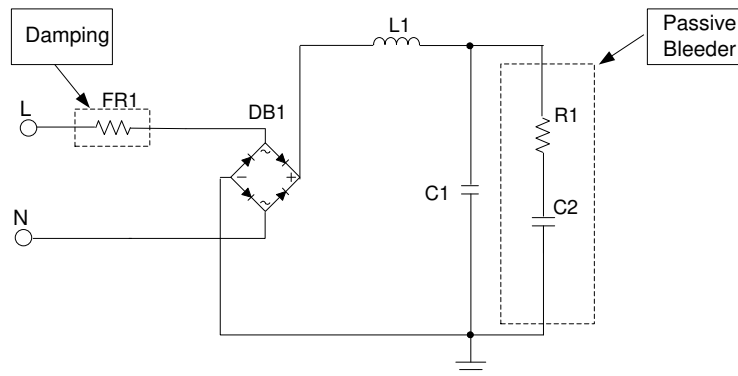

Figure 3. LED Driver Schematic with Passive Bleeder

The passive bleeder includes a capacitor (C2, in hundreds of nF) to provide latching current. A resistor (R1) is necessary to dampen the current spike. Because a large C2 will affect the PF, THD and efficiency, the value of the capacitor (C2) should be selected accordingly. Generally, 100nF/400V to 330nF/400V is recommended. R1 is used to limit the latching current. If R1 is too large, the latching current is not enough and the triac dimmer will misfire causing LED flicker. If R1 is too small, it will result in greater power dissipation. Generally speaking, a 200Ω to 2kΩ resistor is selected for R1.

Passive Damping Design

FR1 is the damper for reducing the spike current caused by quick charging of C2 at firing. In General, FR1 is selected from 20Ω to 100Ω for low line like 120V_{AC} application, and 51Ω to 200Ω for high line like 230V_{AC} application.

Ordering Information

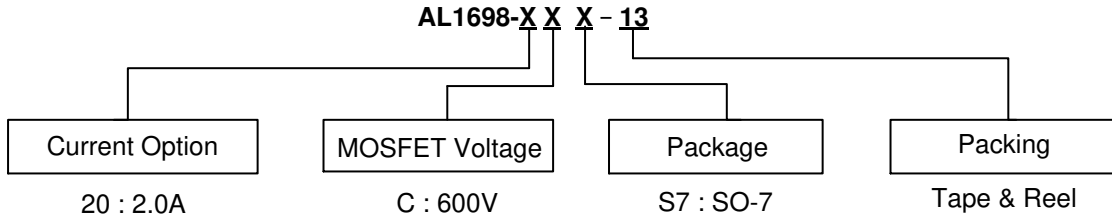

Part Number	Package Code	Package	13" Tape and Reel	
			Quantity	Part Number Suffix
AL1698-20CS7-13	S7	SO-7	4000/Tape & Reel	-13

Marking Information

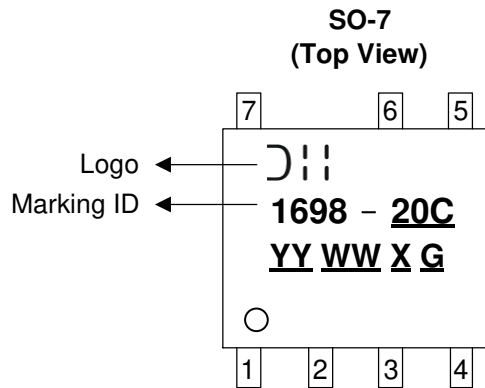

YY : Year : 19, 20, 21~
WW : Week : 01~52; 52
 represents 52 and 53 week
X : T~Z for CAT
 T=Sunday X=Thursday
 U=Monday Y=Friday
 V=Tuesday Z=Saturday
 W=Wednesday
G: Green Compound

NEW PRODUCT

Package Outline Dimensions (All dimensions in mm(inch))

Please see <http://www.diodes.com/package-outlines.html> for the latest version.

(1) Package Type: SO-7

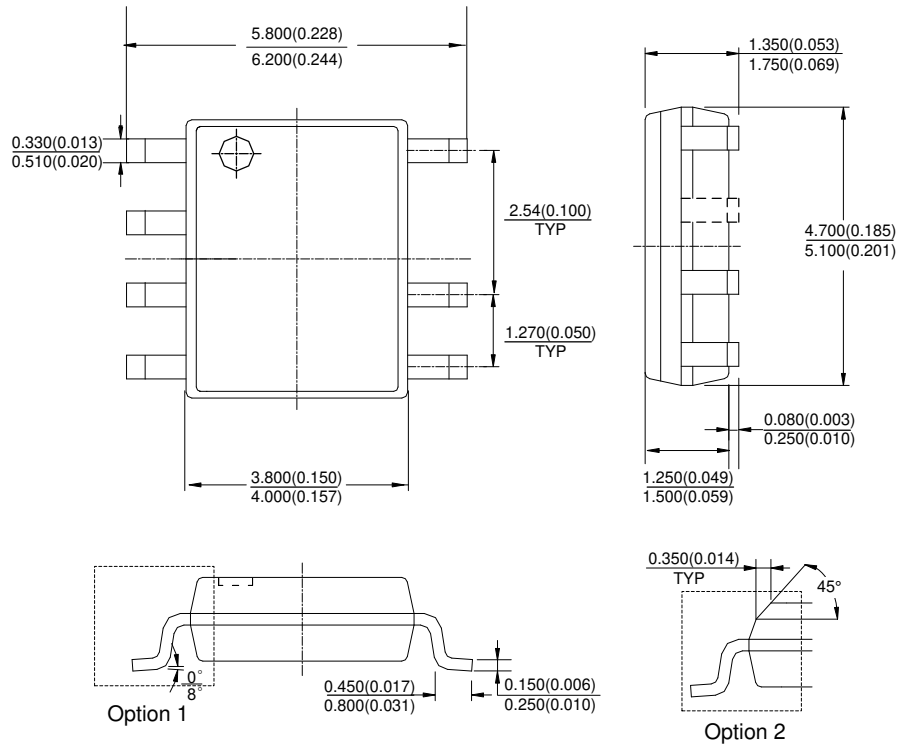

Note: Eject hole, oriented hole and mold mark is optional.

NEW PRODUCT

Suggested Pad Layout

Please see <http://www.diodes.com/package-outlines.html> for the latest version.

(1) Package Type: SO-7

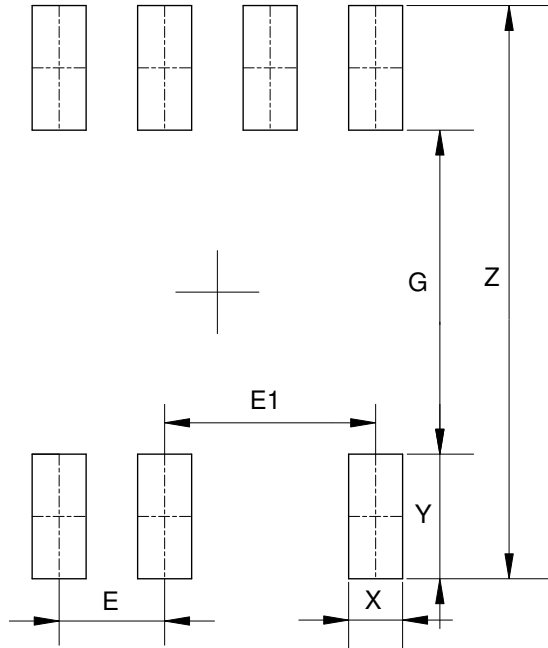

Dimensions	Z (mm)/(inch)	G (mm)/(inch)	X (mm)/(inch)	Y (mm)/(inch)	E (mm)/(inch)	E1 (mm)/(inch)
Value	6.900/0.272	3.900/0.154	0.650/0.026	1.500/0.059	1.270/0.050	2.540/0.100

IMPORTANT NOTICE

DIODES INCORPORATED MAKES NO WARRANTY OF ANY KIND, EXPRESS OR IMPLIED, WITH REGARDS TO THIS DOCUMENT, INCLUDING, BUT NOT LIMITED TO, THE IMPLIED WARRANTIES OF MERCHANTABILITY AND FITNESS FOR A PARTICULAR PURPOSE (AND THEIR EQUIVALENTS UNDER THE LAWS OF ANY JURISDICTION).

Diodes Incorporated and its subsidiaries reserve the right to make modifications, enhancements, improvements, corrections or other changes without further notice to this document and any product described herein. Diodes Incorporated does not assume any liability arising out of the application or use of this document or any product described herein; neither does Diodes Incorporated convey any license under its patent or trademark rights, nor the rights of others. Any Customer or user of this document or products described herein in such applications shall assume all risks of such use and will agree to hold Diodes Incorporated and all the companies whose products are represented on Diodes Incorporated website, harmless against all damages.

Diodes Incorporated does not warrant or accept any liability whatsoever in respect of any products purchased through unauthorized sales channel. Should Customers purchase or use Diodes Incorporated products for any unintended or unauthorized application, Customers shall indemnify and hold Diodes Incorporated and its representatives harmless against all claims, damages, expenses, and attorney fees arising out of, directly or indirectly, any claim of personal injury or death associated with such unintended or unauthorized application.

Products described herein may be covered by one or more United States, international or foreign patents pending. Product names and markings noted herein may also be covered by one or more United States, international or foreign trademarks.

This document is written in English but may be translated into multiple languages for reference. Only the English version of this document is the final and determinative format released by Diodes Incorporated.

LIFE SUPPORT

Diodes Incorporated products are specifically not authorized for use as critical components in life support devices or systems without the express written approval of the Chief Executive Officer of Diodes Incorporated. As used herein:

A. Life support devices or systems are devices or systems which:

1. are intended to implant into the body, or
2. support or sustain life and whose failure to perform when properly used in accordance with instructions for use provided in the labeling can be reasonably expected to result in significant injury to the user.

B. A critical component is any component in a life support device or system whose failure to perform can be reasonably expected to cause the failure of the life support device or to affect its safety or effectiveness.

Customers represent that they have all necessary expertise in the safety and regulatory ramifications of their life support devices or systems, and acknowledge and agree that they are solely responsible for all legal, regulatory and safety-related requirements concerning their products and any use of Diodes Incorporated products in such safety-critical, life support devices or systems, notwithstanding any devices- or systems-related information or support that may be provided by Diodes Incorporated. Further, Customers must fully indemnify Diodes Incorporated and its representatives against any damages arising out of the use of Diodes Incorporated products in such safety-critical, life support devices or systems.

Copyright © 2019, Diodes Incorporated

www.diodes.com