

D-32A Series, Rated up to 100 Amps, 28 Vdc

Product Facts

- 2PST, Center Off, Double Break
- Gasket Sealed, Vented
- Meets many requirements of MIL-PRF-6106



Performance Data

Electrical Characteristics

- Main Contacts —**
Main Contact Configuration — 2PST, Center Off
Voltage, Nom. — 28 Vdc
Resistive Rating — 100 Amps
Inductive Rating — 100 Amps
Motor Rating — 80 Amps
Lamp Rating — 50 Amps
Overload Rating — 800 Amps
Rupture Rating — 1,000 Amps
Auxiliary Contacts —
Aux. Contact Configuration — SPST
Voltage, Nom. — 28 Vdc
Resistive Rating — 0.1 Amps
Inductive Rating — 0.1 Amps
Lamp Rating — 0.1 Amps

General Characteristics

- Temperature Range —** -55°C to +71°C
Operating Cycles (Life) at Rated Resistive Load, Min. — 50,000 cycles
Operating Cycles (Life) Mechanical, Min. — 100,000 cycles
Dielectric Strength —
 All Circuits to Ground — 1,250 Vrms
 Circuit to Circuit — 1,250 Vrms
 Coil to Ground and Aux. Contacts — 1,000 Vrms
Altitude — 50,000 ft.
Weight, Max. — 1.9 lbs

Coil Characteristics

- Duty Cycle —** Continuous with suppression
Operating Voltage, Nom. — 28 Vdc
Operating Voltage, Max. — 30 Vdc
Pickup Voltage, Max. — 18 Vdc
Dropout Voltage, Max. — 1.5 to 7.5 Vdc
Hold Voltage — 8.0 Vdc
Coil Resistance ±10% @ 77°F — 163 Ohms
Coil Current @ 77°F & 30 Vdc, Max. — 0.215 Amp

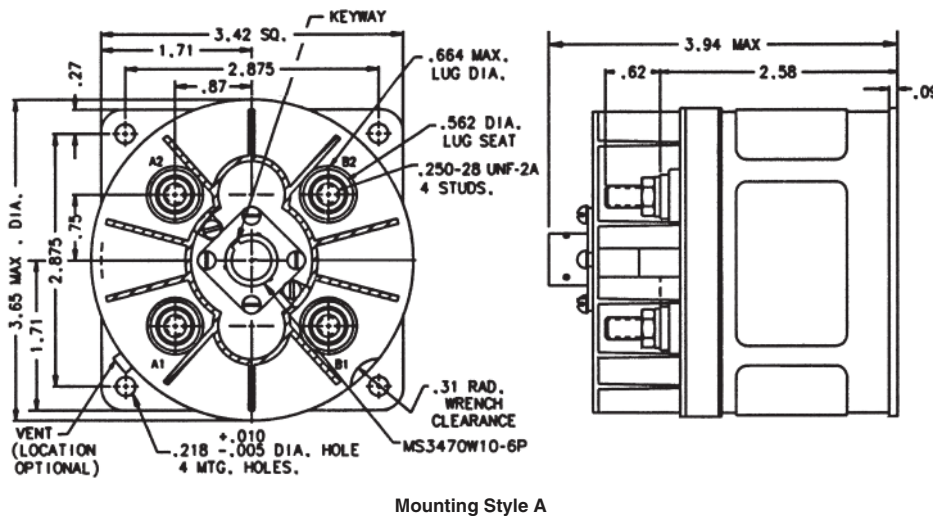

Mounting Style A

Circuit Configurations

(Consult factory for other available circuit configurations)

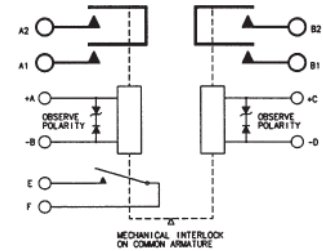

Circuit Configuration 1

For factory-direct application assistance, phone 419-521-9500 or fax 419-526-2749.

HARTMAN Part Number	Construction Type	Mounting Style	Coil Type	Circuit Config.	TE Part Number
D-32A	Gasket/Vented	A	Continuous w/ Suppression	1	1616097-2