

THIS DOCUMENT IS THE PROPERTY OF
KEYSTONE ELECTRONICS CORP. AND
SHALL NOT BE REPRODUCED, DISTRIBUTED
OR USED AS A BASIS FOR MANUFACTURE
WITHOUT PRIOR WRITTEN PERMISSION
FROM KEYSTONE ELECTRONICS CORP.

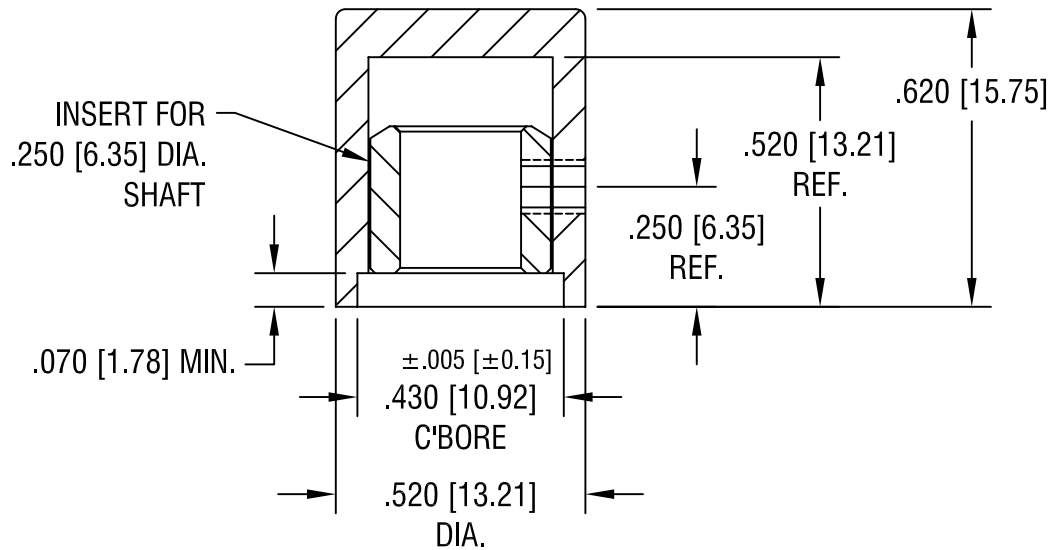
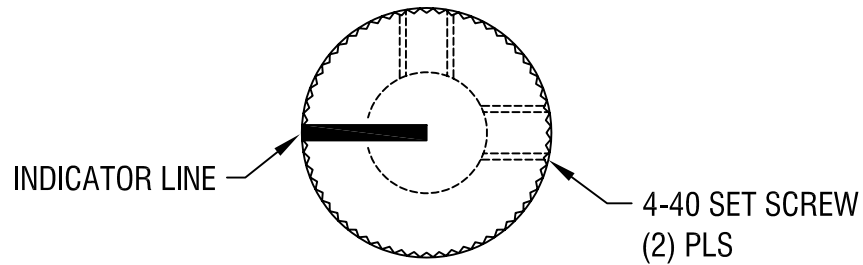

NOTES:

1. KNOB: MAT'L: ABS, BLACK
INSERT: MAT'L: BRASS,
NICKEL PLATE
2. INDICATOR WHITE PAINT LINE
ON TOP & SIDE OF KNOB

KEYSTONE ELECTRONICS CORP.			
ASTORIA, N.Y. 11105-2017			
PART NAME		KNOB	
MATERIAL		AS NOTED	
FINISH		DRN BY	DATE
AS NOTED		BOONE	1.4.07
		APP'D	SCALE
		LN	2.5X
TOLERANCES	INCH [MM]	CODE	DWG NO.
DECIMAL	$\pm .015$ [± 0.38]	C/M	8529
ANGULAR	$\pm 1^\circ$		
UNLESS OTHERWISE SPECIFIED			

DATE	DESCRIPTION	REV.