

AUXILIARY VIEWS  
SCALE 1:1

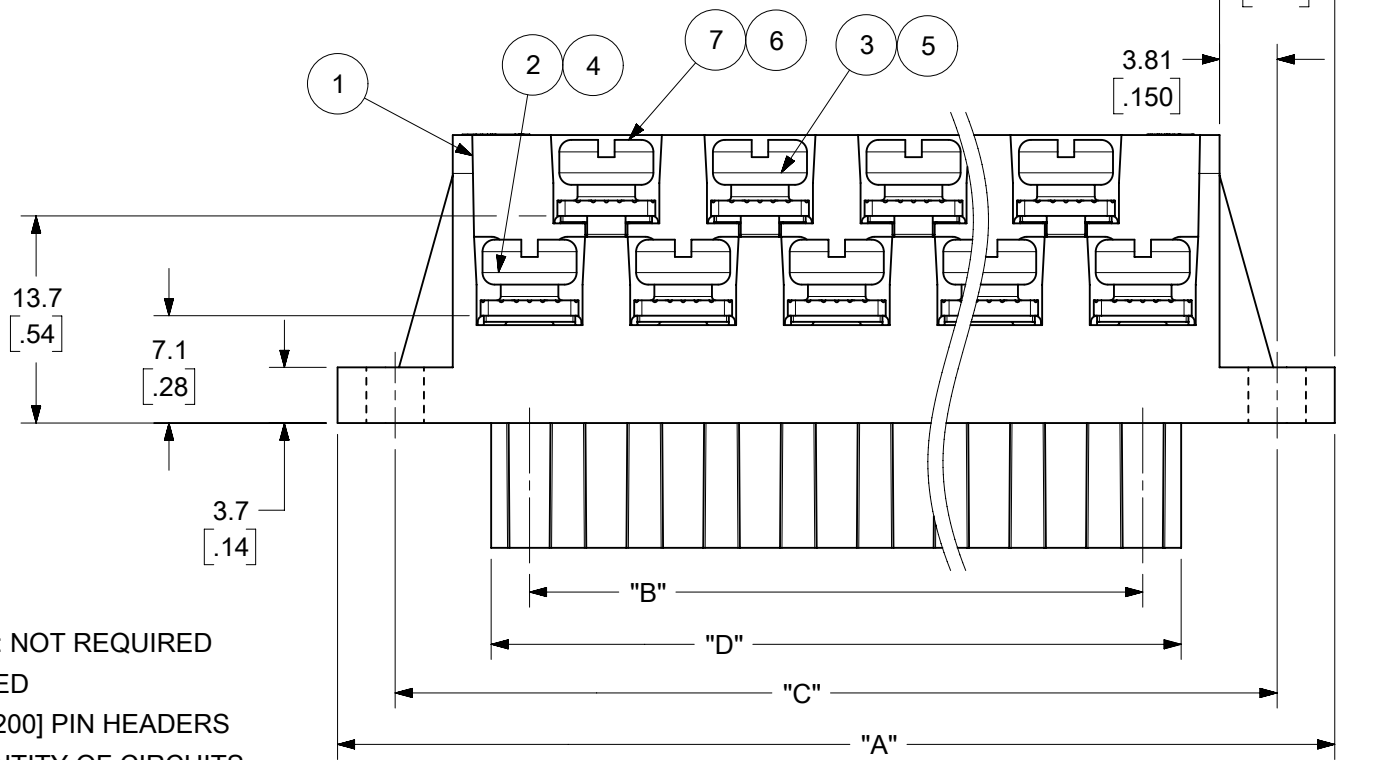

ODD CIRCUIT CONFIGURATION SHOWN

- NOTES:
1. MATERIAL: SEE TABLE
  2. FINISHES: SEE TABLE
  3. PRODUCT SPECIFICATION: NOT REQUIRED
  4. PACKAGING: NOT REQUIRED
  5. MATES WITH: MOST 5.08 [.200] PIN HEADERS
  6. "XX" REFERS TO THE QUANTITY OF CIRCUITS
  7. ROHS COMPLIANT

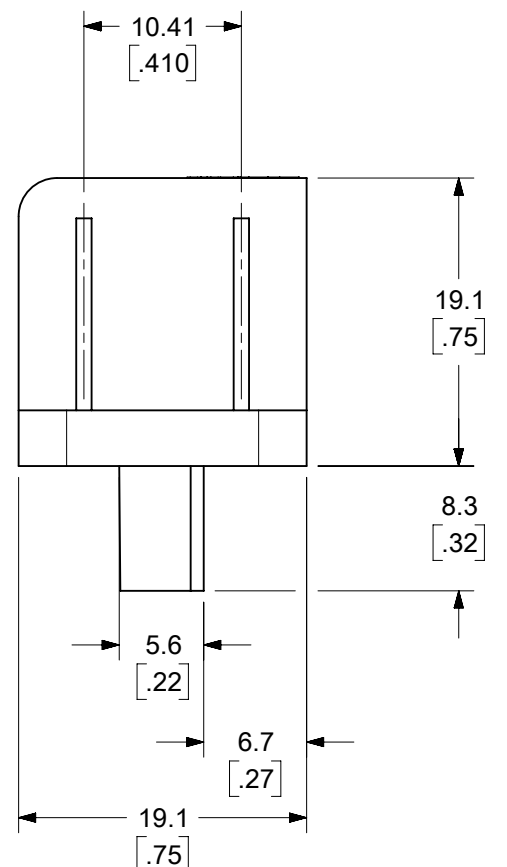

ITEM	QTY. (EVEN NO. OF CIRCUITS)	QTY. (ODD NO. OF CIRCUITS)	DESCRIPTION	MATERIAL	FINISH
7	XX	XX	SCREW, M3.5 X .280	STEEL	ZINC CHROMATE
6	XX	XX	NUT, M3.5, HEX	STEEL	ZINC CHROMATE
5	XX/2	(XX-1)/2	REAR ROW TERMINAL (-G30 OPT.)	PHOS. BRONZE	SELECTIVE GOLD
4	XX/2	(XX+1)/2	FRONT ROW TERMINAL (-G30 OPT.)	PHOS. BRONZE	SELECTIVE GOLD
3	XX/2	(XX-1)/2	REAR ROW TERMINAL	PHOS. BRONZE	HOT TIN DIP
2	XX/2	(XX+1)/2	FRONT ROW TERMINAL	PHOS. BRONZE	HOT TIN DIP
1	1	1	BARRIER	THERMOPLASTIC	BLACK

FUNCTIONAL SYMBOLS						THIS DRAWING CONTAINS INFORMATION THAT IS PROPRIETARY TO MOLEX ELECTRONIC TECHNOLOGIES, LLC AND SHOULD NOT BE USED WITHOUT WRITTEN PERMISSION					
DIMENSION UNITS		SCALE		CURRENT REV DESC: MIGRATED TO ECTR/NX. REMOVED "US PATENT" TEXT FROM MODEL		<p>5.08/.200 PLUG ASSY, FWE WITH BULKHEAD PANEL MTG. ENDS (9479XX)</p>					
MM/INCH		2:1									
GENERAL TOLERANCES (UNLESS SPECIFIED)						EC NO: 677615					
4 PLACES ± .01 ± .01						DRWN: ABENJAMINLW 2021/08/19					
3 PLACES ± .01 ± .005						CHK'D: DACHAMMER 2021/09/09					
2 PLACES ± 0.13 ± .01						APPR: JFMURPHY 2022/01/04					
1 PLACE ± 0.3 ± .01						INITIAL REVISION:					
0 PLACES ± .01 ± .01						DRWN: CYORK 2005/02/23					
ANGULAR TOL ± 2°						APPR: grobertson 2005/03/01					
DRAFT WHERE APPLICABLE MUST REMAIN WITHIN DIMENSIONS						THIRD ANGLE PROJECTION		DRAWING		SERIES	
						B-SIZE		39940		MATERIAL NUMBER	
						SEE SHEET-2		GENERAL MARKET		CUSTOMER	
										SHEET NUMBER	
										1 OF 2	

NO. OF CIRC. "XX"	DIM. "A"		DIM. "B"		DIM. "C"		DIM. "D" $\begin{matrix} +.00 \\ -.25 \end{matrix} \begin{matrix} [+0.00 \\ -.010] \end{matrix}$		MATERIAL NO. (STANDARD)	MATERIAL NO. (-10A OPT.)	MATERIAL NO. (-G30 OPT.)	MATERIAL NO. (-G30, -10A OPT.)
	mm	IN	mm	IN	mm	IN	mm	IN				
03	35.6	[1.40]	10.16	[.400]	27.94	[1.100]	15.2	[.60]	399400703		399410703	
04	40.6	[1.60]	15.24	[.600]	33.02	[1.300]	20.3	[.80]	399400704		399410704	
05	45.7	[1.80]	20.32	[.800]	38.10	[1.500]	25.4	[1.00]	399400705		399410705	
06	50.8	[2.00]	25.40	[1.000]	43.18	[1.700]	30.5	[1.20]	399400706		399410706	
07	55.9	[2.20]	30.48	[1.200]	48.26	[1.900]	35.6	[1.40]	399400707		399410707	
08	61.0	[2.40]	35.56	[1.400]	53.34	[2.100]	40.6	[1.60]	399400708		399410708	
09	66.0	[2.60]	40.64	[1.600]	58.42	[2.300]	45.7	[1.80]	399400709		399410709	
10	71.1	[2.80]	45.72	[1.800]	63.50	[2.500]	50.8	[2.00]	399400710		399410710	
11	76.2	[3.00]	50.80	[2.000]	68.58	[2.700]	55.9	[2.20]	399400711		399410711	
12	81.3	[3.20]	55.88	[2.200]	73.66	[2.900]	61.0	[2.40]	399400712		399410712	
13	86.4	[3.40]	60.96	[2.400]	78.74	[3.100]	66.0	[2.60]	399400713		399410713	
14	91.4	[3.60]	66.04	[2.600]	83.82	[3.300]	71.1	[2.80]	399400714		399410714	
15	96.5	[3.80]	71.12	[2.800]	88.90	[3.500]	76.2	[3.00]	399400715		399410715	
16	101.6	[4.00]	76.20	[3.000]	93.98	[3.700]	81.3	[3.20]	399400716		399410716	
17	106.7	[4.20]	81.28	[3.200]	99.06	[3.900]	86.4	[3.40]	399400717		399410717	
18	111.8	[4.40]	86.36	[3.400]	104.14	[4.100]	91.4	[3.60]	399400718		399410718	
19	116.8	[4.60]	91.44	[3.600]	109.22	[4.300]	96.5	[3.80]	399400719		399410719	
20	121.9	[4.80]	96.52	[3.800]	114.30	[4.500]	101.6	[4.00]	399400720		399410720	
21	127.0	[5.00]	101.60	[4.000]	119.38	[4.700]	106.7	[4.20]	399400721		399410721	
22	132.1	[5.20]	106.68	[4.200]	124.46	[4.900]	111.8	[4.40]	399400722		399410722	
23	137.2	[5.40]	111.76	[4.400]	129.54	[5.100]	116.8	[4.60]	399400723		399410723	
24	142.2	[5.60]	116.84	[4.600]	134.62	[5.300]	121.9	[4.80]	399400724		399410724	399490019

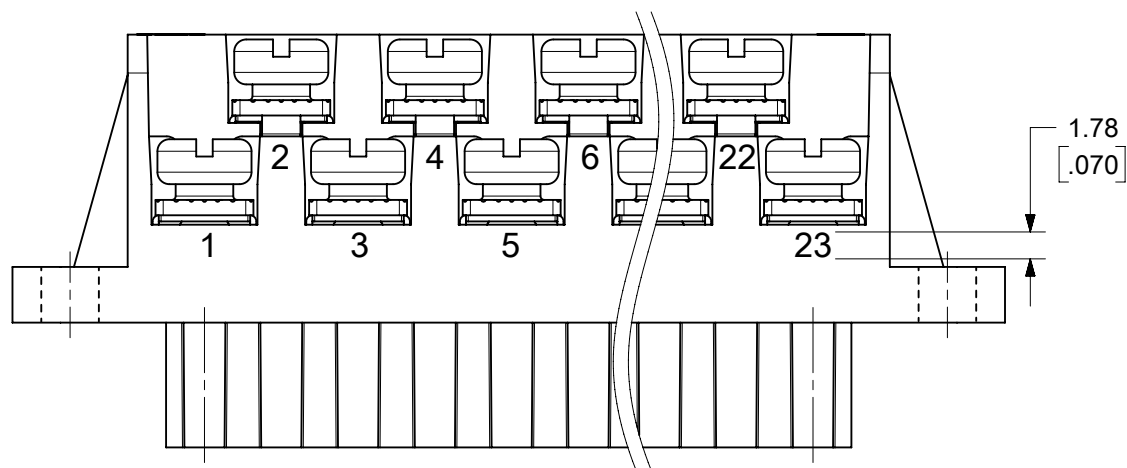

OPTIONAL  
10A IMPRINTING  
(ODD CIRCUIT CONFIGURATION SHOWN)

THIS DRAWING CONTAINS INFORMATION THAT IS PROPRIETARY TO MOLEX ELECTRONIC TECHNOLOGIES, LLC AND SHOULD NOT BE USED WITHOUT WRITTEN PERMISSION											
FUNCTIONAL SYMBOLS	DIMENSION UNITS	SCALE	CURRENT REV DESC: MIGRATED TO ECTR/NX. REMOVED "US PATENT" TEXT FROM MODEL								
$\nabla_A = 0$	MM/INCH	2:1	<b>molex</b> 5.08/.200 PLUG ASSY, FWE WITH BULKHEAD PANEL MTG. ENDS (9479XX)								
$\nabla_E = 0$	GENERAL TOLERANCES (UNLESS SPECIFIED)										
$\nabla_F = 0$			MM		INCH		EC NO: 677615			2021/08/19	
	4 PLACES	±	---	±	---	DRWN: ABENJAMINLW			2021/09/09		
	3 PLACES	±	---	±	.005	CHK'D: DACHAMMER			2022/01/04		
DIVISIONAL SYMBOLS	2 PLACES	±	0.13	±	.01	APPR: JFMURPHY			2022/01/04		
	1 PLACE	±	0.3	±	---	INITIAL REVISION:			DOCUMENT NUMBER		
	0 PLACES	±	---	±	---	DRWN: CYORK			SD-39940-006		
	ANGULAR TOL	±	2°	APPR: grobertson			2005/02/23		DOC TYPE	DOC PART	REVISION
	DRAFT WHERE APPLICABLE MUST REMAIN WITHIN DIMENSIONS		THIRD ANGLE PROJECTION		DRAWING	SERIES	MATERIAL NUMBER	CUSTOMER	SHEET NUMBER		
			B-SIZE		39940	SEE CHART	GENERAL MARKET	2 OF 2			

NO. OF CIRC. "XX"	"A"	"B"	"C"	"D" <sup>+0.00</sup> <sub>-.25</sub> [ <sup>+0.000</sup> <sub>-.010</sub> ]	MATERIAL NO.	MATERIAL NO. (-10A OPT.)	MATERIAL NO. (-G30 OPT.)	MATERIAL NO. (-G30,-10A OPT.)
03	35.6 [1.40]	10.16 [4.00]	27.94 [1.100]	15.2 [.60]	399400703		399410703	
04	40.6 [1.60]	15.24 [6.00]	33.02 [1.300]	20.3 [.80]	399400704		399410704	
05	45.7 [1.80]	20.32 [8.00]	38.10 [1.500]	25.4 [1.00]	399400705		399410705	
06	50.8 [2.00]	25.40 [10.00]	43.18 [1.700]	30.5 [1.20]	399400706		399410706	
07	55.9 [2.20]	30.48 [12.00]	48.26 [1.900]	35.6 [1.40]	399400707		399410707	
08	61.0 [2.40]	35.56 [14.00]	53.34 [2.100]	40.6 [1.60]	399400708		399410708	
09	66.0 [2.60]	40.64 [16.00]	58.42 [2.300]	45.7 [1.80]	399400709		399410709	
10	71.1 [2.80]	45.72 [18.00]	63.50 [2.500]	50.8 [2.00]	399400710		399410710	
11	76.2 [3.00]	50.80 [20.00]	68.58 [2.700]	55.9 [2.20]	399400711		399410711	
12	81.3 [3.20]	55.88 [22.00]	73.66 [2.900]	61.0 [2.40]	399400712		399410712	
13	86.4 [3.40]	60.96 [24.00]	78.74 [3.100]	66.0 [2.60]	399400713		399410713	
14	91.4 [3.60]	66.04 [26.00]	83.82 [3.300]	71.1 [2.80]	399400714		399410714	
15	96.5 [3.80]	71.12 [28.00]	88.90 [3.500]	76.2 [3.00]	399400715		399410715	
16	101.6 [4.00]	76.20 [30.00]	93.98 [3.700]	81.3 [3.20]	399400716		399410716	
17	106.7 [4.20]	81.28 [32.00]	99.06 [3.900]	86.4 [3.40]	399400717		399410717	
18	111.8 [4.40]	86.36 [34.00]	104.14 [4.100]	91.4 [3.60]	399400718		399410718	
19	116.8 [4.60]	91.44 [36.00]	109.22 [4.300]	96.5 [3.80]	399400719		399410719	
20	121.9 [4.80]	96.52 [38.00]	114.30 [4.500]	101.6 [4.00]	399400720		399410720	
21	127.0 [5.00]	101.60 [40.00]	119.38 [4.700]	106.7 [4.20]	399400721		399410721	
22	132.1 [5.20]	106.68 [42.00]	124.46 [4.900]	111.8 [4.40]	399400722		399410722	
23	137.2 [5.40]	111.76 [44.00]	129.54 [5.100]	116.8 [4.60]	399400723		399410723	
24	142.2 [5.60]	116.84 [46.00]	134.62 [5.300]	121.9 [4.80]	399400724		399410724	399490019

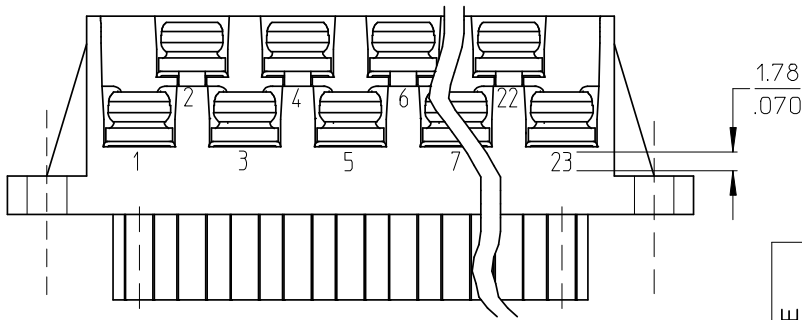

OPTIONAL  
10A IMPRINTING  
(ODD CIRCUIT CONFIGURATION SHOWN)

SEE SHEET ONE EEC NO: WNA2008-0391 DRAWN: JENCINAS 2008/07/01 CHKD: CYORK 2008/07/02 APPR: JMACNEIL 2008/07/07 REV DESCRIPTION	QUALITY SYMBOLS	GENERAL TOLERANCES (UNLESS SPECIFIED)	DIMENSION STYLE	SCALE	DESIGN UNITS	THIRD ANGLE PROJECTION	
	▼=0 ▽=0	mm INCH 4 PLACES ± --- ± --- 3 PLACES ± --- ± .005 2 PLACES ± 0.13 ± .01 1 PLACE ± 0.3 ± --- ANGULAR ± 2 °	MM/IN	2:1	INCH		
		DRAFT WHERE APPLICABLE MUST REMAIN WITHIN DIMENSIONS	DRAWN BY C. YORK CHECKED BY R. KEMP APPROVED BY GHR	DATE 2005/02/22 DATE 2005/02/22 DATE 2005/02/22	TITLE 5.08/.200 PLUG ASSY, FWE WITH BULKHEAD PANEL MTG. ENDS (9479XX)		
			MATERIAL NO. SEE CHART	MOLEX INCORPORATED DOCUMENT NO. SD-39940-006		SHEET NO. 2 OF 2	

THIS DRAWING CONTAINS INFORMATION THAT IS PROPRIETARY TO MOLEX INCORPORATED AND SHOULD NOT BE USED WITHOUT WRITTEN PERMISSION