

THIS DRAWING IS A CONTROLLED DOCUMENT.

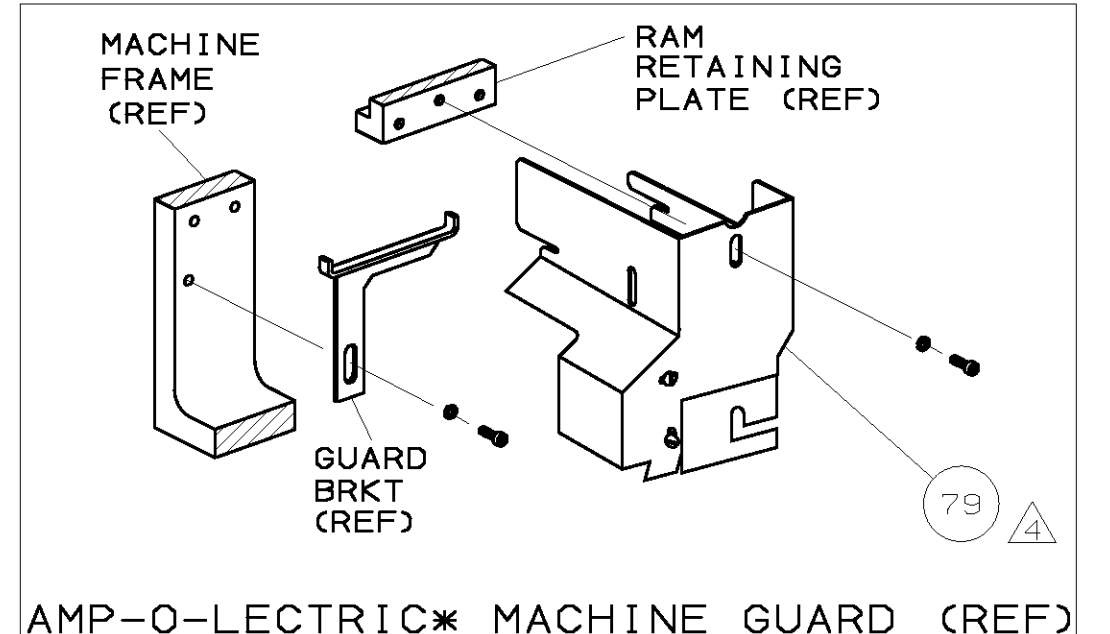
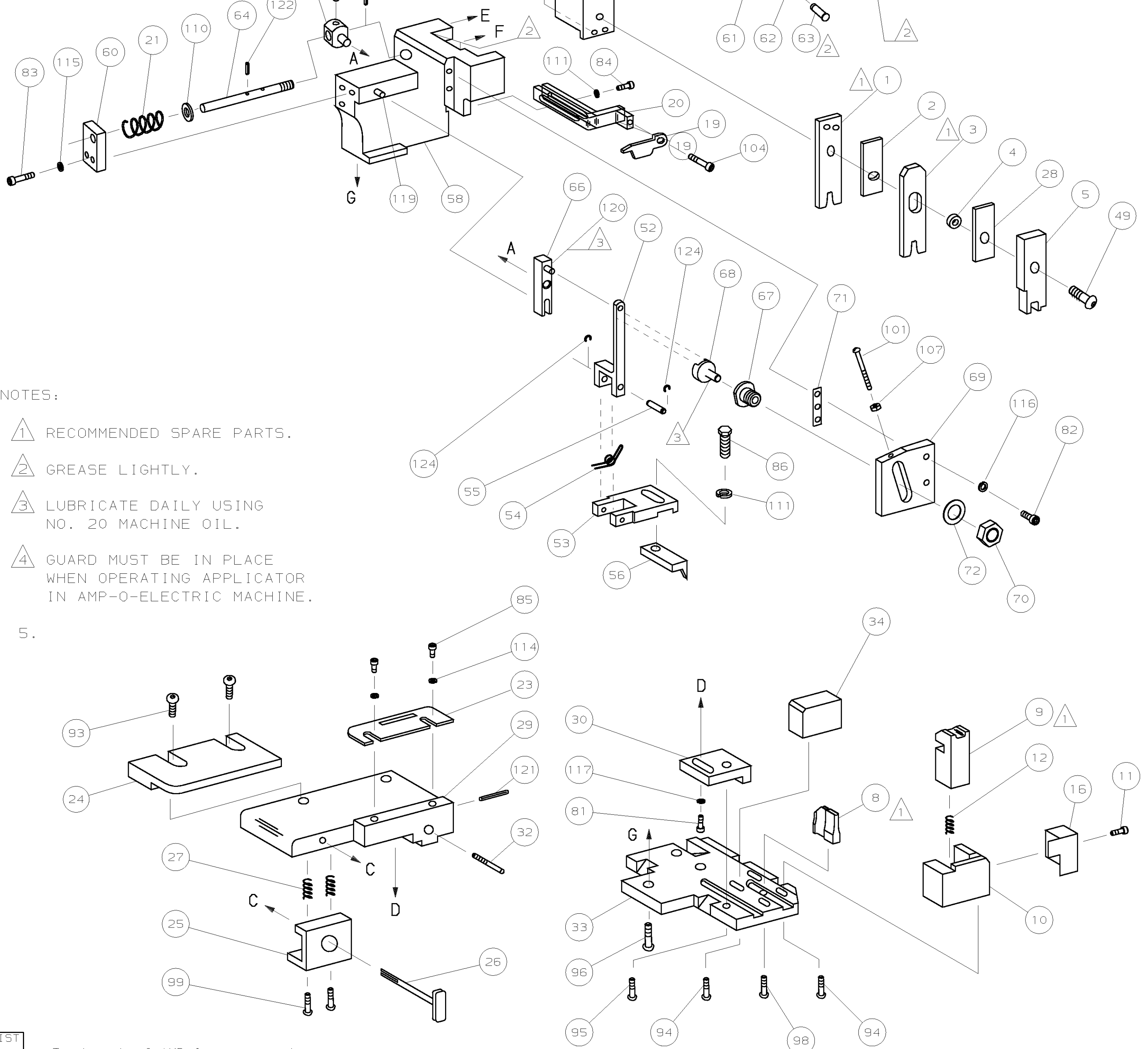
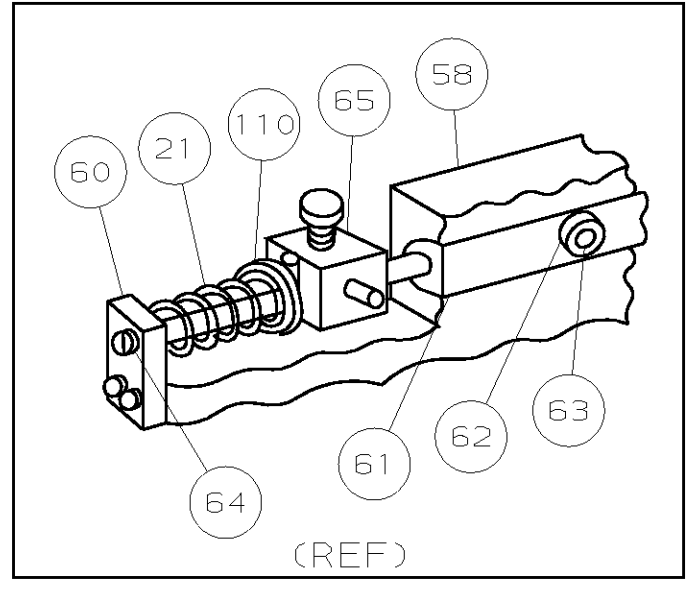
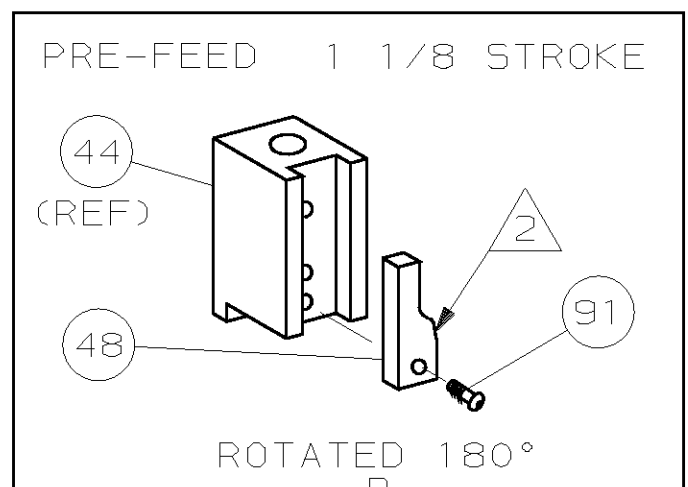

AMP-O-ELECTRIC* MACHINE GUARD (REF)

- NOTES:
- 1 RECOMMENDED SPARE PARTS.
 - 2 GREASE LIGHTLY.
 - 3 LUBRICATE DAILY USING NO. 20 MACHINE OIL.
 - 4 GUARD MUST BE IN PLACE WHEN OPERATING APPLICATOR IN AMP-O-ELECTRIC MACHINE.

THIS DRAWING IS UNCLASSIFIED... AMP INCORPORATED, HARRISBURG, PA.

66 * Trademark of AMP Incorporated

| | | | | | | | |
|-----|-----------|--|-----|-----|------------|------------------------------|----|
| REF | 21045-3 | RING, RET "C" (.187ø) FEED FINGER PIN | 124 | REF | 454220-1 | CAP, HOUSING | 59 |
| | | | 123 | REF | 454485-1 | HOUSING | 58 |
| REF | 5-21028-1 | PIN, SLT SPR (.125øx.50) ADJ ROD | 122 | | | | 57 |
| 1 | 4-21028-0 | PIN, SLT SPR (.093øx.75) ST GUIDE PL | 121 | 1 | 690542-2 | PAWL, FEED | 56 |
| REF | 1-21030-1 | PIN, DOWEL (.187øx.50) LEVER | 120 | REF | 240624-1 | PIN, FEED FINGER | 55 |
| REF | 1-21030-6 | PIN, DOWEL (.187øx1.25) HOUSING | 119 | REF | 691499-1 | SPRING, FEED FINGER | 54 |
| | | | 118 | REF | 690541-1 | FINGER, FEED | 53 |
| 1 | 21024-5 | WASHER, LOCK (NO.10) ADJ BLOCK | 117 | REF | 455679-1 | LEVER, TERMINAL FEED ARM | 52 |
| REF | 21024-5 | WASHER, LOCK (NO.10) ADJ PLATE | 116 | 1 | 811242-2 | BUMPER, HOLDDOWN | 51 |
| REF | 21024-5 | WASHER, LOCK (NO.10) FEED GUIDE ROD | 115 | 1 | 690753-1 | SPACER, TONKER | 50 |
| 2 | 21024-2 | WASHER, LOCK (NO.4) FRONT STRIP GUIDE | 114 | 1 | 7-21002-9 | BOLT, CRIMPER (5/16-24x1.00) | 49 |
| | | | 113 | 1 | 690602-5 | CAM, PRE-FEED 1 1/8 STROKE | 48 |
| | | | 112 | | | | 47 |
| 4 | 21024-4 | WASHER, LOCK (NO.8) STRIPPER | 111 | 1 | 459456-1 | APPLICATOR, BASIC (SUBASSY) | 46 |
| REF | 21899-4 | WASHER, FLAT (5/16 DIA) SCREW ADJ | 110 | 1 | 690191-1 | PLUG, NYLON | 45 |
| | | | 109 | 1 | 455673-1 | RAM | 44 |
| 1 | 21018-5 | NUT, HEX (NO.6) HOLDDOWN | 108 | 1 | 690125-1 | WASHER, LAMINATED | 43 |
| REF | 21018-5 | NUT, HEX (6-32) FEED ADJ | 107 | 1 | 690124-1 | WASHER, RAM | 42 |
| | | | 106 | | | | 41 |
| | | | 105 | 2 | 23241-6 | BALL, STEEL | 40 |
| 1 | 456567-1 | SCR, SHLD (.188øx.125) STRIPPER | 104 | 2 | 690170-1 | SPRING, COMPRESSION | 39 |
| 1 | 21009-2 | SCR, SKT SET (1/4-20x.25) LOC-WEL) RAM | 103 | 1 | 690142-1 | DISC, INSULATION | 38 |
| 2 | 21017-2 | SCR, DRIVE (#2x.19) ID PLATE | 102 | 1 | 8-692155-7 | DISC, WIRE | 37 |
| REF | 6-23715-5 | SCR, PAN HD (6-32x1.50) FEED ADJ | 101 | 1 | 22480-5 | WASHER, SPRING | 36 |
| 1 | 461264-1 | PLATE, IDENTIFICATION | 100 | 1 | 690212-1 | POST, RAM | 35 |
| 2 | 2-21002-9 | SCR, BHC (10-32x.75) DRAG | 99 | 1 | 692776-2 | SUPPORT, TERMINAL | 34 |
| 1 | 22733-8 | SCR, BHC (8-32x.38) LOC-WEL) ANVIL | 98 | REF | 455675-1 | PLATE, BASE | 33 |
| REF | 2-21002-9 | SCR, BHC (10-32x.75) CAP | 97 | 1 | 690432-3 | SCREW, ADJUSTMENT | 32 |
| REF | 2-22733-8 | SCR, BHC (1/4-20x.62) HOUSING | 96 | | | | 31 |
| REF | 2-21002-7 | SCR, BHC (10-32x.50) SG ADJ BLOCK | 95 | REF | 455689-1 | BLOCK, STRIP GUIDE ADJ | 30 |
| 4 | 2-21002-2 | SCR, BHC (8-32x.50) SHEAR | 94 | 1 | 455671-1 | PLATE, STRIP GUIDE | 29 |
| 2 | 2-21000-8 | SCR, BHC (8-32x.62) R STRIP GUIDE | 93 | 1 | 2-455888-2 | SPACER, FRONT SHEAR DEP | 28 |
| | | | 92 | 2 | 1-22284-0 | SPRING, DRAG | 27 |
| 1 | 1-21002-7 | SCR, BHC (6-32x.38) CAM | 91 | 1 | 690546-1 | LEVER, DRAG RELEASE | 26 |
| | | | 90 | 1 | 240792-1 | DRAG, STOCK | 25 |
| | | | 89 | 1 | 690504-9 | GUIDE, STRIP (REAR) | 24 |
| | | | 88 | 1 | 690438-1 | GUIDE, STRIP (FRONT) | 23 |
| | | | 87 | | | | 22 |
| 1 | 2-22603-0 | SCR, HEX HEAD (8-32x.31) FEED FINGER | 86 | REF | 4-22284-9 | SPRING, FEED RETURN | 21 |
| 2 | 1-21000-3 | SCR, SKT CAP (4-40x.25) F STRIP GUIDE | 85 | 1 | 458950-1 | ARM, STRIPPER | 20 |
| 3 | 2-21000-7 | SCR, SKT CAP (8-32x.50) STRIPPER | 84 | 1 | 458949-1 | STRIPPER | 19 |
| REF | 3-21000-7 | SCR, SKT CAP (10-32x.75) FEED ROD GD | 83 | | | | 18 |
| REF | 3-21000-6 | SCR, SKT CAP (10-32x.62) FEED ADJ BLK | 82 | | | | 17 |
| 1 | 3-21000-4 | SCR, SKT CAP (10-32x.38) SG ADJ BLK | 81 | 1 | 691667-1 | GUARD, CHIP (FRONT) | 16 |
| REF | 3-21000-4 | SCR, SKT CAP (10-32x.38) PIVOT BLOCK | 80 | | | | 15 |
| REF | 455749-1 | GUARD, WINDOW | 79 | | | | 14 |
| | | | 78 | | | | 13 |
| | | | 77 | 1 | 5-22280-0 | SPRING, SHEAR | 12 |
| | | | 76 | 1 | 690461-1 | STOP, SHEAR | 11 |
| | | | 75 | 1 | 690459-1 | HOLDER, SHEAR (FRONT) | 10 |
| | | | 74 | 1 | 462006-1 | SHEAR, FLOAT (FRONT) | 9 |
| 2 | 690603-1 | SPRING, ASSIST | 73 | 1 | 7-803653-8 | ANVIL | 8 |
| 2 | 23030-1 | SCR, SKT CAP (6-32x.25) CP DISC | 72 | 1 | 5-240641-4 | SPACER, HOLD-DOWN | 7 |
| REF | 458109-1 | WASHER, SPECIAL | 71 | | | | 6 |
| REF | 690517-1 | SPACER | 70 | | | | 5 |
| REF | 22594-8 | NUT, HEX | 69 | 1 | 1-455889-4 | DEPRESSOR, SHEAR (FRONT) | 4 |
| REF | 240628-1 | PLATE, ADJUSTMENT | 68 | 1 | 238011-7 | SPACER, TUBULAR | 3 |
| REF | 240626-1 | SHAFT, PIVOT | 67 | 1 | 2-683453-4 | CRIMPER, INSULATION | 2 |
| REF | 240633-1 | BUSHING | 66 | 1 | 455888-5 | SPACER, CRIMPER | 1 |
| REF | 455680-1 | LEVER, INTERMEDIATE | 65 | | | | 1 |
| REF | 240629-1 | BLOCK, PIVOT | 64 | | | | |
| REF | 240632-2 | SCREW, ADJUSTMENT FEED ROD | 63 | | | | |
| REF | 240659-3 | PIN, CAM ROLLER | 62 | | | | |
| REF | 240658-1 | ROLLER, CAM | 61 | | | | |
| REF | 454398-2 | ROD, FEED | 60 | | | | |
| REF | 454178-1 | GUIDE, FEED ROD | 59 | | | | |

| | | | |
|-------------------------|---------------------|------------------|-------------------|
| QTY | PART NO | DESCRIPTION | ITEM NO |
| CRIMPING DATA | | | |
| PAD LTR | CRIMP HEIGHT | WIRE SIZE | WIRE STRIP LENGTH |
| A | .078 | 14 | |
| B | .066 | 16 | |
| C | .059 | 18 | |
| D | NOT USED | | |
| CRIMP | SIZE | TYPE | FEED |
| WIRE | .090 | F | .433 |
| INSUL | .190 | F | |
| WIRE RANGE | 18-14 | INSULATION RANGE | .089-.154 |
| REMARKS | MACHINE NO 565435-5 | | |
| AMP-O-ELECTRIC PRE-FEED | | | |

| | | |
|------------------------------|----------------|----------------|
| REMARKS | NO | REV |
| APPL USED ON MACHINE PART NO | SPEC 114-5044 | |
| CUSTOMER NAME | APPL SERIAL NO | DISTRIBUTION |
| ADDRESS | PURCHASE ORDER | ORIGINAL |
| CITY | ENG APP | CUSTOMER COPY |
| | | FIELD ENG COPY |